

Please carefully read and save these instructions before attempting to assemble, maintain, install, or operate this product. Observe all safety information to protect yourself and others. Failure to observe the instructions may result in property damage and/or personal injury. Please keep instructions for future reference.

Important Operating Instructions

HEAVY DUTY 6/12 VOLT CHARGER with ENGINE START **Model: 7216**

CALIFORNIA PROPOSITION 65

WARNING: You can create dust when you cut, sand, drill or grind materials such as wood, paint, metal, concrete, cement, or other masonry. This dust often contains chemicals known to cause cancer, birth defects, or other reproductive harm. Wear protective gear.

WARNING: This product or its power cord may contain chemicals, including lead, known to the State of California to cause cancer and birth defects or other reproductive harm. Wash hands after handling.

CAUTION:

FOR YOUR OWN SAFETY, READ INSTRUCTION MANUAL COMPLETELY AND CAREFULLY BEFORE OPERATING THIS CHARGER ENGINE STARTER.

GENERAL SAFETY WARNING

Please read and understand all instructions. Failure to follow all instructions listed below may result in electric shock, fire, and/or serious personal injury.

WARNING: When using tool, basic safety precautions should always be followed to reduce the risk of personal injury and damage to the equipment.

SPECIFICATIONS

- 100/200 Amp Emergency Starter
- 6/12 Volt
- Amp meter monitors
- Heavy duty, 80" charging cables
- 135 minutes charge timer with hold
- 12V/10A for trickle charging car batteries
- 12V/40A fast charging
- 12V/200A for starting
- 6V/40A fast charging
- 6V/100A for starting

SAFETY INSTRUCTIONS

1. SAVE THESE INSTRUCTIONS - This manual contains important safety and operating instructions for this battery charger.
2. Do not expose charger to rain or snow.
3. Use of an attachment not recommended or sold by the manufacturer may result in a risk of fire, electric shock, or injury.

4. To reduce risk of damage to the electric plug and cord, pull by plug rather than cord when disconnecting charger.

5. An extension cord should not be used unless absolutely necessary. Use of improper extension cord could result in a risk of fire and electric shock. If an extension cord must be used, make sure:

- a. That pins on plugs of extension cord are the same number, size, and shape as those of plug on the charger;
- b. That extension cord is properly wired and in good electrical condition; and
- c. That wire size is large enough for AC ampere rating of charger as specified in Table 1.

6) Do not operate charger with damaged cord or plug - replace the cord or plug immediately.

7) Do not operate charger if it has received a sharp blow, been dropped, or otherwise damaged in any way; take it to a qualified serviceman.

8) Do not disassemble charger; take it to a qualified serviceman when service or repair is required.

For warranty purchases, please keep your dated proof of purchase. File or attach to the manual for safe keeping.

Incorrect reassembly may result in a risk of electric shock or fire.

9) To reduce risk of electric shock, unplug charger from outlet before attempting any maintenance or cleaning. Turning off controls will not reduce this risk.

10. **WARNING: RISK OF EXPLOSIVE GASES.**

a. WORKING IN VICINITY OF A LEAD-ACID BATTERY IS DANGEROUS. BATTERIES GENERATE EXPLOSIVE GASES DURING NORMAL BATTERY OPERATION. FOR THIS REASON, IT IS OF UTMOST IMPORTANCE THAT YOU FOLLOW THE INSTRUCTIONS EACH TIME YOU USE THE CHARGER.

b. To reduce risk of battery explosion, follow these instructions and those published by battery manufacturer of any equipment you intend to use in vicinity of battery. Review cautionary markings on this product and on the engine.

11. **PERSONAL PRECAUTIONS**

a. Consider having someone close enough by to come to your aid when you work near a lead-acid battery.

b. Have plenty of fresh water and soap nearby in case battery acid contacts skin, clothing, or eyes.

c. Wear complete eye protection and clothing protection. Avoid touching eyes while working near battery.

d. If battery acid contacts skin or clothing, wash immediately with soap and water. If acid enters eye, immediately flood eye with running cold water for at least 10 minutes and get medical attention immediately.

e. NEVER smoke or allow a spark or flame in vicinity of battery or engine.

f. Be extra cautious to reduce risk of dropping a metal tool onto battery. It might spark or short-circuit battery or other electrical part that may cause explosion.

g. Remove personal metal items such as rings, bracelets, necklaces, and watches when working with a lead-acid battery. A lead-acid battery can produce a short-circuit current high enough to weld a ring or the like to metal, causing a severe burn.

h. Use charger for charging a LEAD-ACID battery only. It is not intended to supply power to a low voltage electrical system other than in a starter-motor application. Do not use battery charger for charging dry-cell batteries that are commonly used with home appliances. These batteries may burst and cause injury to persons and damage to property.

i. NEVER charge a frozen battery.

12. **PREPARING TO CHARGE**

a. If necessary to remove battery from vehicle to charge, always remove grounded terminal from battery first. Make sure all accessories in the vehicle are off, so as not to cause an arc.

b. Be sure area around battery is well ventilated while battery is being charged.

c. Clean battery terminals. Be careful to keep corrosion from coming in contact with eyes.

d. Add distilled water in each cell until battery acid reaches level specified by battery manufacturer. Do not overfill. For a battery without removable cell caps, such as valve regulated lead acid batteries, carefully follow manufacturer's recharging instructions.

e. Study all battery manufacturer's specific precautions while charging and recommended rates of charge.

f. Determine voltage of battery by referring to vehicle owner's manual and make sure it matches output rating of battery charger. If charger has adjustable charge rate, charge battery initially at lowest rate.

13. **CHARGER LOCATION**

a. Locate charger as far away from battery as DC cables permit.

b. Never place charger directly above battery being charged; gases from battery will corrode and damage charger.

c. Never allow battery acid to drop on charger when reading electrolyte specific gravity or filling a battery.

d. Do not operate charger in a closed-in area or restrict ventilation in any way.

e. Do not set a battery on top of a charger.

14. **DC CONNECTION PRECAUTIONS**

a. Connect and disconnect DC output clips only after setting any charger switches to OFF position and removing AC cord from electric outlet. Never allow clips to touch each other.

b. Attach clips to battery and chassis as indicated in 15(e), 15(f), and 16(b) through 16(d).

15. FOLLOW THESE STEPS WHEN A BATTERY IS INSTALLED IN A VEHICLE. A SPARK NEAR BATTERY MAY CAUSE BATTERY EXPLOSION. TO REDUCE THE RISK OF A SPARK NEAR A BATTERY:

- a. Position AC and DC cords to reduce risk of damage by hood, door, or moving engine parts.
- b. Stay clear of fan blades, belts, pulleys, and other parts that can cause injury to persons.
- c. Check polarity of battery posts. POSITIVE (POS, P, +) battery post usually has larger diameter than NEGATIVE (NEG, N, -) post.
- d. Determine which post of battery is grounded (connected) to the chassis. If negative post is grounded to chassis (as in most vehicles), see (e). If positive post is grounded to the chassis, see (f).
- e. For negative-grounded vehicle, connect POSITIVE (RED) clip from battery charger to POSITIVE (POS, P, +) ungrounded post of battery. Connect NEGATIVE (BLACK) clip to vehicle chassis or engine block away from battery. Do not connect clip to carburetor, fuel lines, or sheet-metal body parts. Connect to a heavy gauge metal part of the frame or engine block.
- f. For positive-grounded vehicle, connect NEGATIVE (BLACK) clip from battery charger to NEGATIVE (NEG, N, -) ungrounded post of battery. Connect POSITIVE (RED) clip to vehicle chassis or engine block away from battery. Do not connect clip to carburetor, fuel lines, or sheet-metal body parts. Connect to a heavy gauge metal part of the frame or engine block.
- g. When discovering charger, turn switches to OFF, disconnect AC cord, remove clip from vehicle

chassis, and then remove clip from battery terminal.

h. See operating instructions for length of charge information.

16. FOLLOW THESE STEPS WHEN BATTERY IS OUTSIDE VEHICLE. A SPARK NEAR THE BATTERY MAY CAUSE BATTERY EXPLOSION. TO REDUCE RISK OF A SPARK NEAR THE BATTERY:

- a. Check polarity of battery posts. POSITIVE (POS, P, +) battery post usually has a larger diameter than NEGATIVE (NEG, N, -) post.
- b. Attach at least a 24-inch-long 6-gauge (AWG) insulated battery cable to NEGATIVE (NEG, N, -) battery post.
- c. Connect POSITIVE (RED) charger clip to POSITIVE (POS, P, +) post of battery.
- d. Position yourself and free end of cable as far away from battery as possible - then connect NEGATIVE (BLACK) charger clip to free end of cable.
- e. Do not face battery when making final connection.
- f. When disconnecting charger, always do so in reverse sequence connecting procedure and break first connection while as far away from battery as practical.
- g. A marine (boat) battery must be removed and charged on shore. To charge it on board requires equipment specially designed for marine use.

17. WEAR ANSI-APPROVED SPLASH-RESISTANT SAFETY GOGGLES AND HEAVY-DUTY RUBBER WORK GLOVES WHENEVER CONNECTING, DISCONNECTING, OR WORKING NEAR BATTERY. BATTERY ACID CAN CAUSE PERMANENT BLINDNESS.

18. Maintain labels and nameplates on the charger. These carry important safety information.

19. This product is not a toy. Keep out of reach of children.

20. Unplug the battery charger from its electrical outlet before connecting its cables to a battery, or performing any inspection, maintenance, or cleaning procedures.

21. This charger/starter does NOT have an automatic shut-off. It is equipped with a timer. Check battery and time manually; do NOT depend solely on timer. Leaving charger/starter unattended can result in fire and property damage.

22. Use this battery charger with flooded lead-acid batteries only. When charging a maintenance-free battery, always monitor the progress of the charge by viewing the ammeter. Do not overcharge a maintenance-free battery.

23. Do not attempt to charge non-rechargeable or defective batteries.

24. Do not charge more than one battery at a time.

25. Have your charger serviced by a qualified repair person using only identical replacement parts. This will ensure that the safety of the charger is maintained.

26. Do not use charger while you are tired or under the influence of drugs, alcohol, or medication. A moment of inattention while operating charger may result in serious personal injury.

27. Before moving charger, disconnect power supply and battery, then allow charger to cool.

28. People with pacemakers should consult their physician(s) before use. Electromagnetic fields in close proximity to heart pacemaker could cause pacemaker interference or pacemaker failure. In addition, people with pacemakers should:

- a. Avoid operating alone.
- b. Properly maintain and inspect to avoid electric shock.
- c. Properly ground power cord. Ground Fault Circuit Interrupter (GFCI) should also be implemented - it prevents sustained electrical shock.

29. **WARNING:** Handling the cord on this product will expose you to lead, a chemical known to the State of California to cause cancer, and birth defects or other reproductive harm. Wash hands after handling. (California Health & Safety Code 25249.5, et seq.)

30. The warnings, precautions, and instructions discussed in this instruction manual cannot cover all possible conditions and situations that may occur. It must be understood by the operator that common sense and caution are factors which cannot be built into this product, but must be supplied by the operator.

SAVE THESE INSTRUCTIONS

Grounding and AC power cord connection instructions

Charger should be grounded to reduce risk of electric shock. Charger is equipped with an electric cord having an equipment-grounding conductor and a grounding plug. The plug must be plugged into an outlet that is properly installed and grounded in accordance with all local codes and ordinances.

DANGER: Never alter AC cord or plug provided - if it will not fit outlet, have proper outlet installed by a qualified electrician. Improper connection can result in a risk of an electric shock.

CAUTION: Risk of Fire or Electric Shock. Connect battery charger directly to grounding receptacle (three-prong). An adapter should not be used with battery charger.

ASSEMBLY INSTRUCTIONS

Read the ENTIRE safety information section at the beginning of this manual before set-up or use of this product.

WARNING: TO PREVENT SERIOUS INJURY: Unplug the charger, disconnect any battery, and allow charger to cool completely before assembling or making any adjustments to the charger.

Note: For additional information regarding the parts listed in the following pages, refer to the PARTS LIST Diagram.

1. Place the Battery Charger/Starter on its side.
2. Use two screws to install the mounting foot to the front bottom of the Charger/Starter (Figure A).

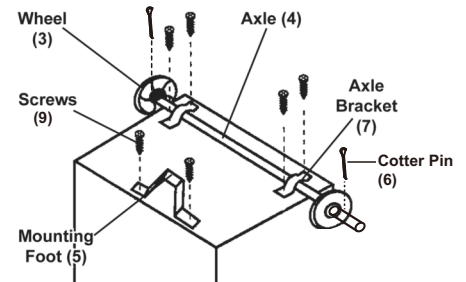

Figure A: Foot and Wheel Installation

3. Slide the wheels onto each end of the axle and use cotter pins to hold the wheels.

Note: Verify the hub of each wheel is facing in.

4. Set the axle along the bottom of the Charger/Starter and align the axle brackets with the mounting holes. Once aligned, fasten the wheel axle into place.

5. Stand up the Charger/Starter.

6. Remove the two top screws on each side of the Charger/Starter and set the handle against the unit, aligning the mounting holes (Figure B).

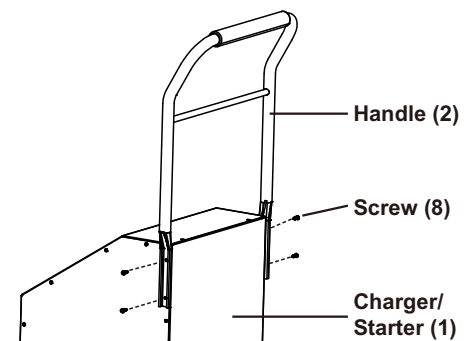

Figure B: Handle Installation

7. Use the screws to mount the handle on the sides of the Charger/Starter.

OPERATING INSTRUCTIONS

Read the **ENTIRE** safety information section at the beginning of this manual before set-up or use of this product.

WARNING: To prevent serious injury, assemble charger according to Assembly Instructions before use.

DO NOT PLUG IN CHARGER UNTIL DIRECTED TO DO SO

CONTROLS

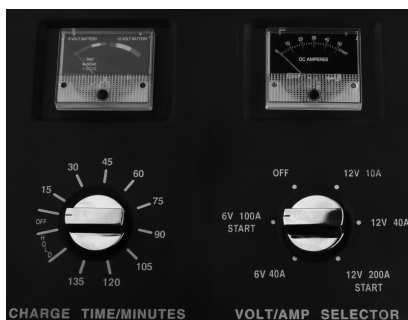

Figure C: Controls

Timer Dial: The timer prevents over-charging while allowing a battery the needed time to obtain a satisfactory charge. To set the timer, you must know the size of battery in ampere hours or reserve capacity in minutes, and the state of charge. The state of charge can be obtained using a battery load tester (not included). For example, the average size automotive battery at 50% charge will require 1 to 1-1/2 hours of charging at 40 amp rate to reach full charge state. For the same battery with the timer set to maximum, overcharging will occur. *Slight* overcharging should not harm a battery that was otherwise in good condition. When the state of charge is unknown, start out with a timer setting of one hour or less.

Hold: (on timer dial) This sets the charger for continuous operation. Use for long-period charging, such as when the lowest charge rate is selected. **WARNING: To prevent serious injury and fire, monitor charging and stop charge when battery is fully charged.**

Setting Dial: Use this to set the voltage/ampere output.

Ammeter: The ammeter indicates amount of current measured in amperes that is drawn from battery. For example, in 40 amp charge rate a typical discharged battery will initially draw approximately 40 amps. As battery continues to charge, current will taper to 15 to 20 amps at full charge. When cranking an engine, starter motor draws up to 200 amps.

When a battery is close to being dead or has a very low charge, it will want to draw more current. When a dead or low battery is charged, the charger's ammeter will register at high end. As the battery charges, the reading will move down toward the low end, resting on zero, when battery is fully charged.

Do not depend on reading ammeter to approximate how long charging will take.. Even at full charge, ammeter will still provide as much as 50% of charger's output rating. Sometimes conditions such as a cold battery, a sulfated battery, or a deeply discharged lead calcium battery may cause ammeter to read near a full charge when charging process is only beginning.

Note: The ammeter shows the amount of current being drawn from the charger. It does not show what the charger is capable of delivering. When the battery is fully charged and registering zero on the ammeter, a small charge will continue to move from the charger to the battery. If the

charger is not disconnected from the battery, eventually heat build up will cause the battery acid to boil and overcharge the battery causing damage to the battery. Monitor battery charging progress constantly and if battery gets warm, stop charging it immediately.

PREPARING TO CHARGE

Use this charger only on flooded lead-acid batteries. Other batteries may be damaged or may overheat, leak, or catch fire.

WARNING: To prevent serious injury, wear ANSI-approved splash-resistant safety goggles and heavy-duty rubber work gloves whenever connecting, disconnecting, or working near battery. Battery acid can cause permanent blindness.

1. If necessary to remove battery from vehicle to charge, always remove grounded terminal from battery first. Make sure all accessories in the vehicle are off, so as not to cause an arc.
2. Be sure area around battery is well-ventilated while battery is being charged.
3. Clean battery terminals. Be careful to keep corrosion from coming in contact with eyes.
4. Add distilled water in each cell until battery acid reaches level specified by battery manufacturer. Do not overfill. For a battery without removable cell caps, such as valve regulated lead acid batteries, carefully follow manufacturer's recharging instructions.
5. Study all battery manufacturer's specific precautions while charging and recommended rates of charge.
6. Determine voltage of battery by referring to vehicle owner's manual and make sure it matches output rating of battery charger. If charger

has adjustable charge rate, charge battery initially at lowest rate.

7. A marine (boat) battery must be removed and charged on shore on shore. To charge it on board requires equipment specially designed for marine use.

SHORTED BATTERIES will read on an ammeter as a high end peg at beginning of charging process. If after 5-10 minutes, needle does not move off high end, the battery probably has a short circuit. Unplug charger and discontinue use. Have battery checked by a qualified technician.

COLD BATTERIES begin charging at a low rate, increase as battery reaches a normal temperature, then rate will decrease normally. **DO NOT CHARGE A FROZEN BATTERY.**

BATTERIES WITH HYDROMETER EYE: Do not depend on hydrometer eye to determine battery charge level.

CHARGER LOCATION

1. Locate charger as far away from battery as DC cables permit.
2. Never place charger directly above battery being charged; gases from battery will corrode and damage charger.
3. Never allow battery acid to drip on charger when reading electrolyte specific gravity or filling battery.
4. Do not operate charge in a closed-in area or restrict ventilation in any way.
5. Do not set a battery on top of charger.

WARNING: To prevent serious injury, fire, and property damage, monitor charging during use. This Charger/Starter is not automatic and can overcharge

and damage a battery if allowed to operate for extended periods of time.

CHARGING BATTERY INSTALLED IN VEHICLE

A spark near battery may cause battery explosion. To reduce risk of a spark near battery follow these instructions exactly.

WARNING: To prevent serious injury, wear ANSI-approved splash-resistant safety goggles and heavy-duty rubber work gloves whenever connecting, disconnecting, or working near battery. Battery acid can cause permanent blindness.

1. Position AC and DC cables to reduce risk of damage by hood, door, or moving engine parts.
2. Stay clear of fan blades, belts, pulleys, and other parts that can cause injury to persons.
3. Check polarity of battery posts. POSITIVE (POS, P, +) battery post usually has larger diameter than NEGATIVE (NEG, N, -) post.
4. Determine which post of battery is grounded (connected) to the chassis. If negative post is grounded to the chassis (as in most vehicles). See 5. If positive post is grounded to the chassis, see 6.
5. For negative-grounded vehicle, connect POSITIVE (RED) clip from battery charger to POSITIVE (POS, P, +) ungrounded post of battery. Connect NEGATIVE (BLACK) clip to vehicle chassis or engine block away from battery. Do not connect clip to carburetor, fuel lines, or sheet-metal body parts. Connect to a heavy gauge metal part of the frame or engine block.
6. For positive-grounded vehicle, connect NEGATIVE (BLACK) clip from battery charger to NEGATIVE (NEG, N, -) ungrounded post of

battery. Connect POSITIVE (RED) clip to vehicle chassis or engine block away from battery. Do not connect clip to carburetor, fuel lines, or sheet-metal body parts. Connect to a heavy gauge metal part of the frame or engine block.

7. When disconnecting charger, turn switches to OFF, disconnect AC cord, remove clip from vehicle chassis, and then remove clip from battery terminal.

8. See Table 2 for length of charge information.

9. After use clean, then store the charger indoors out of children's reach.

CHARGING BATTERY OUTSIDE VEHICLE

A spark near battery may cause battery explosion. To reduce risk of a spark near battery follow these instructions exactly.

WARNING: To prevent serious injury, wear ANSI-approved splash-resistant safety goggles and heavy-duty rubber work gloves whenever connecting, disconnecting, or working near battery. Battery acid can cause permanent blindness.

1. Check polarity of battery posts. POSITIVE (POS, P, +) battery post usually has a larger diameter than NEGATIVE (NEG, N, -) post.
2. Attach at least a 24-inch-long 6-gauge (AWG) insulated battery cable to NEGATIVE (NEG, N, -) battery post.
3. Connect POSITIVE (RED) charger clip to POSITIVE (POS, P, +) post of battery.
4. Position yourself and free end of cable as far away from battery

as possible - then connect NEGATIVE (BLACK) charger clip to free end of cable.

5. Do not face battery when making final connection.

6. When disconnecting charger, always do so in reverse sequence of connecting procedure and break first connection while as far away as practical.

7. See Table 2 for length of charge information.

8. After use, clean then store the charger indoors out of reach of children.

ENGINE STARTING

NOTICE: Some vehicles with onboard computers may be damaged from the high-current starting output. Thoroughly read the vehicle service manual before using this procedure.

Note: During extremely cold weather or when battery is severely exhausted, charge the battery for about five minutes before attempting to turn ON engine.

1. Set the charge rate and timer to the OFF positions.

2. Plug the charger AC power cord into the AC outlet.

3. Set the Volt/Amp selector to the correct setting. Make sure setting of engine start charge rate matches the vehicle battery.

4. For negative-grounded vehicle, connect POSITIVE (RED) clip from battery charger to POSITIVE (POS, P, +) ungrounded post of battery. Connect NEGATIVE (BLACK) clip to vehicle chassis or engine block away from battery. Do not connect clip to carburetor, fuel lines, or sheet-metal body parts. Connect to a heavy gauge metal part of the frame or engine block.

5. Position AC and DC cables to reduce risk of damage by hood, door, or moving engine parts.

6. **WARNING: To prevent serious injury, fire, and damage to starter and battery, follow duty cycle for each start mode as follows:**

110A, 6V: 60 second maximum with 90 second minimum rest.

200A, 12V: 5 second maximum with 240 second minimum rest.

7. To start the engine, set the charge time dial to HOLD and turn ignition key. **ONLY KEEP CHARGER IN START MODE AS LONG AS THE DUTY CYCLE LISTED ALLOWS.**

Note: If the unit beeps, the cables are reversed or touching (short-circuited) and the engine starter will power off. Check that cables are connected properly.

8. If engine fails to start, charge battery for an additional five minutes before attempting to start.

9. After the engine starts, move the charge rate switch to OFF and unplug the power cord from the outlet before disconnecting the DC cable clamps.

MAINTENANCE INSTRUCTIONS

Procedures not specifically explained in this manual must be performed by a qualified technician.

WARNING: To prevent serious injury, unplug the charger, disconnect any battery, and allow charger to cool completely before performing any inspection, maintenance, or cleaning procedures.

WARNING: To prevent serious injury from tool failure, do not use damaged equipment. If abnormal noise or vibration occurs, have the problem corrected before further use.

1. **BEFORE EACH USE**, inspect the general condition of the charger. Check for loose hardware, misalignment or binding of moving parts, cracked or broken parts, damaged electrical wiring, and any other condition that may affect its safe operation.

2. **AFTER USE**, wipe external surfaces with a clean cloth.

3. **WARNING: If the supply cord of this charger is damaged, it must be replaced by a qualified service technician. DO NOT OPEN CHARGER HOUSING, NO USER-SERVICEABLE PARTS INSIDE.**

TABLE 1: RECOMMENDED EXTENSION CORD

AC input Rating, amperes*		AWG size of cord			
		Length of cord, feet			
Equal to or great than	But less than	25	50	100	150
8	10	18	14	12	10
10	12	16	14	10	8
12	14	16	12	10	8
14	16	16	12	10	8
16	18	14	12	8	8
18	20	14	12	8	6

TABLE 2: CHARGING RATE/TIME

Battery Size/Rating			Charge Rate	
			Charging Time (based on battery at 50% charge)	
			10A, 12V	40A, 12V
Small batteries (Motorcycle, Garden Tractor, etc.)		6-12 Ah	not use these rates for small batteries	
Cars/Trucks	200-315 CCA	40-60 RC	1-1/2~4 hr	1/2~3/4 hr
	315-550 CCA	60-85 RC	4~7 hr	3/4~2 hr
	550-875 CCA	85-125 RC	7~11 hr	2~3 hr

NOTES: * Charge Rates for this model are listed on front panel. ** Based on battery at 50% charge
 AH = Ampere Hours NR = Not Recommended CCA = Cold Cranking Amps RC = Reserve Capacity

Troubleshooting Guide

Symptom	Possible Cause(s)	Corrective Action
Ammeter display reads maximum	Defective battery	Check or replace battery
No ammeter reading	No power to engine starter	Check power and cable outlet connections
	Battery cables not making connection	Clean battery cables and reset cable clamps
	Two amp charge rate being used	None, meter will not indicate here
Charging current not to full output	Battery is partially charged	Continue charging
	Defective battery will not hold full charge	Check and/or replace battery
Ammeter needle moves up to full charge, then drops to zero. Makes clicking noise	Reversed battery connections	Double-check connection polarity. If wrong, shut-off charger and correct cable lead connections.
	Battery is completely dead	Continue charging battery. Charger will continue to reset itself until the battery reaches a chargeable level.
	Defective battery	Check and/or replace battery
	Charge engine starter is resetting itself after circuit overload	Wait until charger automatically resets itself
	Circuit breaker is cycling	May be the wrong switch position

Limited Manufacturer Warranty

FOT makes every effort to ensure that this product meets high quality and durability standards. FOT warrants to the original retail consumer a 1-year limited warranty from the date the product was purchased at retail and each product is free from defects in materials. Warranty does not apply to defects due directly or indirectly to misuse, abuse, negligence or accidents, repairs or alterations, or a lack of maintenance. FOT shall in no event be liable for death, injuries to persons or property, or for incidental, special or consequential damages arising from the use of our products. To receive service under warranty, the original manufacturer part must be returned for examination by an authorized service center. Shipping and handling charges may apply. If a defect is found, FOT will either repair or replace the product at its discretion.

DO NOT RETURN TO STORE

For Customer Service:

Email: customerservice@focus-ontools.com or Call 1-800-348-5004

HEAVY DUTY 6/12 VOLT CHARGER with ENGINE START

Parts List

Model: 7216

#	Description	QTY.	#	Description	QTY.
1	Charger/ Starter	1	6	Cotter Pin	2
2	Handle	1	7	Axle Brackets	2
3	Wheels	2	8	Screw (4x12mm)	4
4	Axle	1	9	Screw (5x11mm)	6
5	Mounting Foot	1			

