

seville classics®

Extra-Large 7-Tier 22-Bin Commercial-Grade NSF-Certified Bin Rack

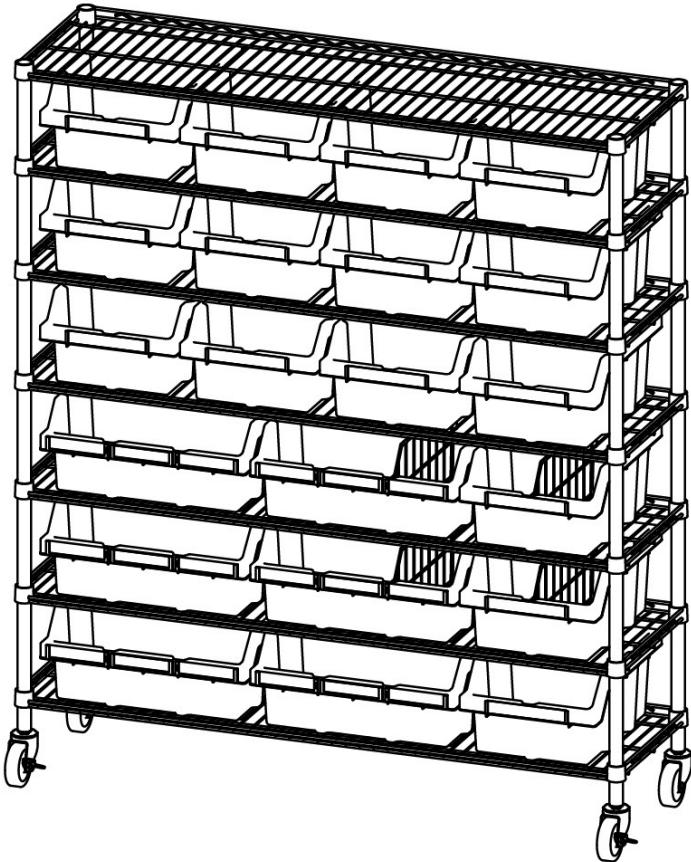

Model: WEB678

Thank you for choosing Seville Classics! We hope that you enjoy your new bin storage rack. Please read through this user guide for parts list, assembly instructions, frequently asked questions and contact information.

Parts List

A. Shelf (7)



B. Bottom poles (4)

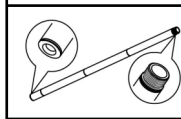

C. Top poles (4)

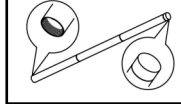

D. Extra-large bins (4)

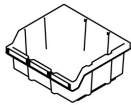

E. Large bins (18)

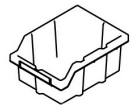

F. Dividers (4)

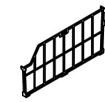

G. Slip sleeves (56)

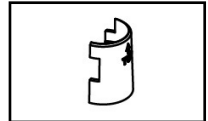

H. Locking wheels (2)



I. Wheels (3)



J. Leveling feet (4)

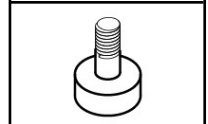

K. Short labels (4)

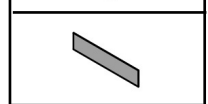

L. Long labels (18)

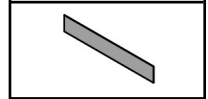

Please make sure you have all the parts on this list.

If you're missing parts, contact us for replacements at (800) 323-5565 or send an email to Support@SevilleClassics.com

Assembly Instructions

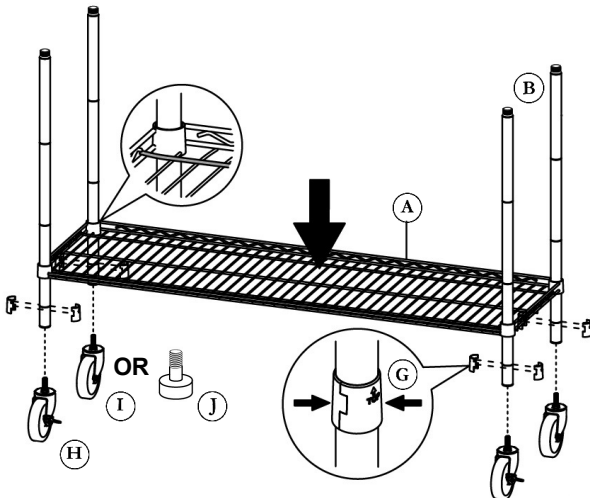

STEP 1.

Screw in either **WHEELS (H, I)** or **LEVELING FEET (J)** into **BOTTOM POLES (B)**.

STEP 2.

Snap **SLIP SLEEVES (G)** around the grooves on **BOTTOM POLES (B)** for the lowest shelf.

Fit **SHELF (A)** over slip sleeves. Press down until snug.

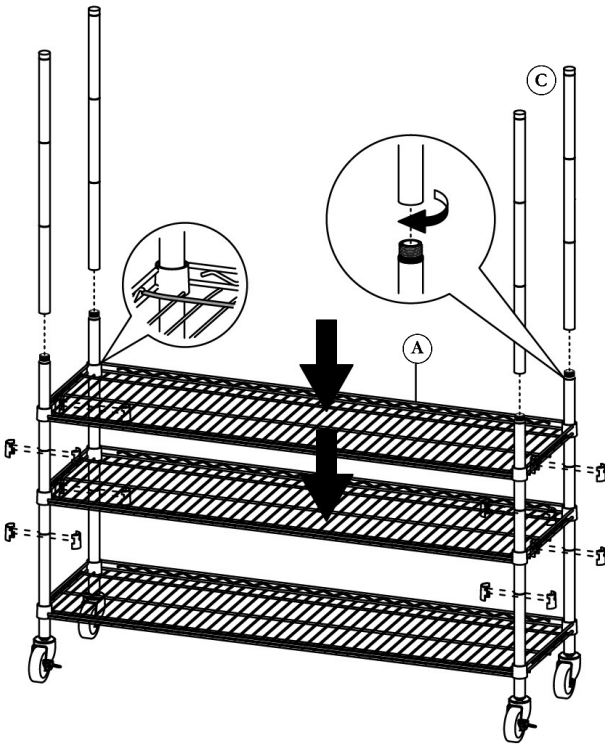

STEP 3.

Repeat STEP 2 for the next 2 shelves.

Screw in **TOP POLES (C)**.

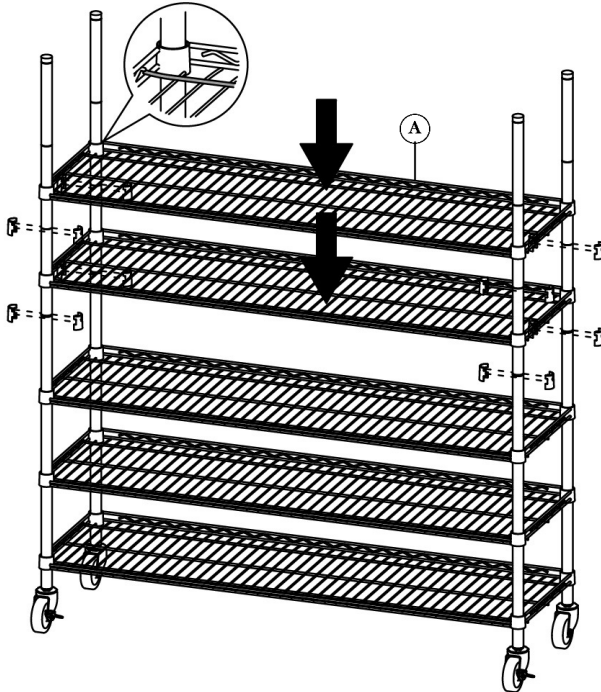

STEP 3.

Snap **SLIP SLEEVES (G)** around the grooves on top poles for the remaining shelves.

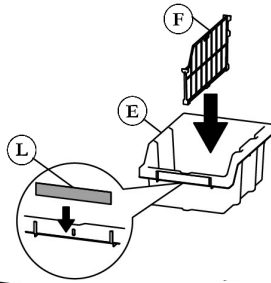
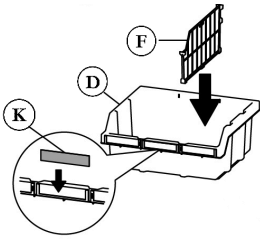

STEP 4.

Insert **SHORT LABELS (K)** into **EXTRA-LARGE BINS (D)** and **LONG LABELS (L)** into **LARGE BINS (E)**.

Insert **DIVIDERS (F)** as needed.

Place bins onto shelves to complete.

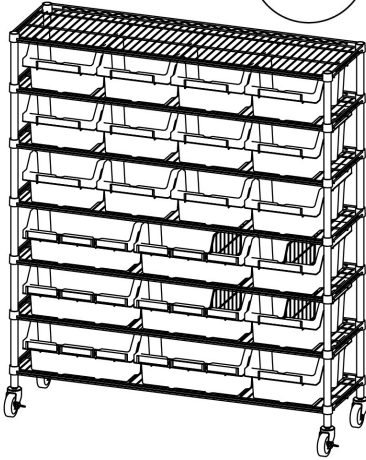

Congratulations!
Enjoy your Extra-Large
Commercial Bin
Storage Rack

Caution

- Place heavier items on the lower shelves and lighter ones on the top.
- Do not stand or climb on the shelving system.
- Do not drop heavy items on the system.
- Do not move the system while loaded.

Specifications

Dimensions: 48" W x 14.25" D x 63.5" H

Weight capacity	Per shelf	Overall
On wheels	71.4 lbs. (32.4 kg.)	500 lbs. (226.8 kg.)

Customer Service Information

Telephone: (800) 323-5565

Fax: (310) 533-3899

Hours: 8:30 AM – 4:30 PM (PST)

Email: Support@SevilleClassics.com

Homepage: www.SevilleClassics.com