

## USE AND CARE GUIDE LED FLOOD LIGHT

### PACKAGE CONTENTS

Part	Description	Quantity
A	Fixture Body	1
B1	Kunckle Bracket	1
B2	Slip-fitter Bracket	1
C	Wire nut	5

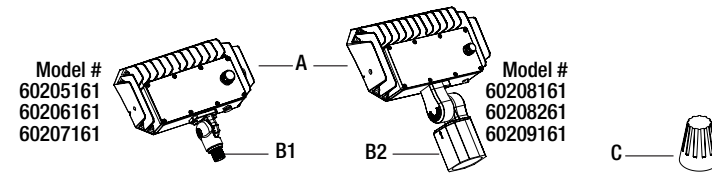

### ADDITIONAL PARTS AVAILA BLE TO PURCHASE

Part	Description	Quantity
AA	Yoke Bracket	1
BB	PG Head	1
CC	Hex Bolts	2
DD	Flat Washers	4
EE	Spring Washers	2

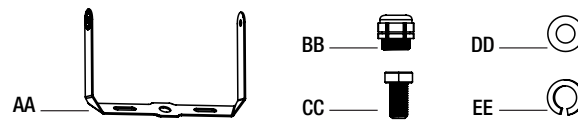

**NOTE:** The hardware kit for yoke mounting is sold as a separate accessory. Visit [www.HomeDepot.com](http://www.HomeDepot.com) for more information and to purchase.

**NOTE:** Separate parts not shown to actual size.

**NOTE:** Keep your receipt and these instructions for proof of purchase.

**WARNING:** RISK OF ELECTRIC SHOCK. Ensure the electricity to the wires you are working on is shut off. Either remove the fuse or turn off the circuit breaker before removing an existing light fixture or installing the new one.

If you are unfamiliar with electrical installations, we recommend you contact a qualified electrician to do the installation.

### INSTALLATION

Select a suitable location that can support the weight of the fixture. Determine the method for mounting the fixture before drilling, based on the type of installation location.

#### SLIP-FITTER MOUNTING (FOR MODEL# 60208161/ 60208261/ 60209161)

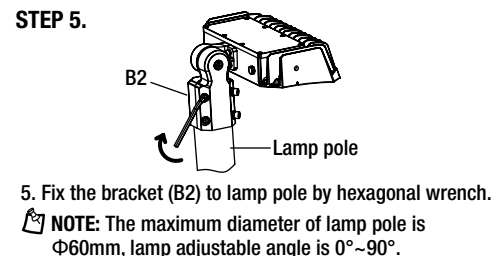
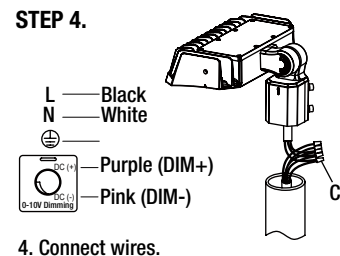
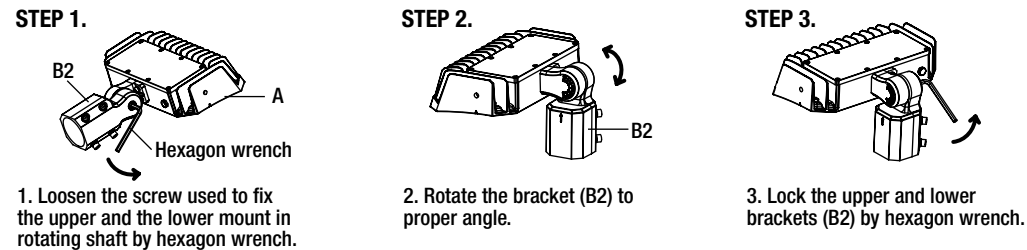

#### KUNCKLE MOUNTING (FOR MODEL# 60205161/ 60206161/ 60207161)

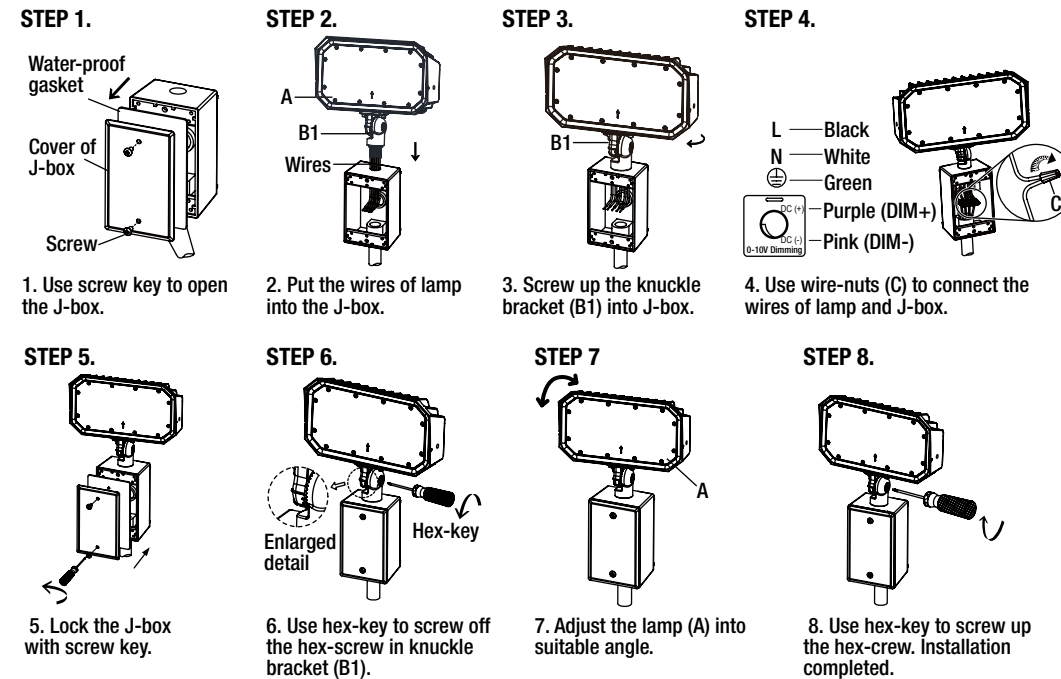

#### YOKE MOUNTING (FOR MODEL# 60207161/ 60208161/ 60208261/ 60209161)

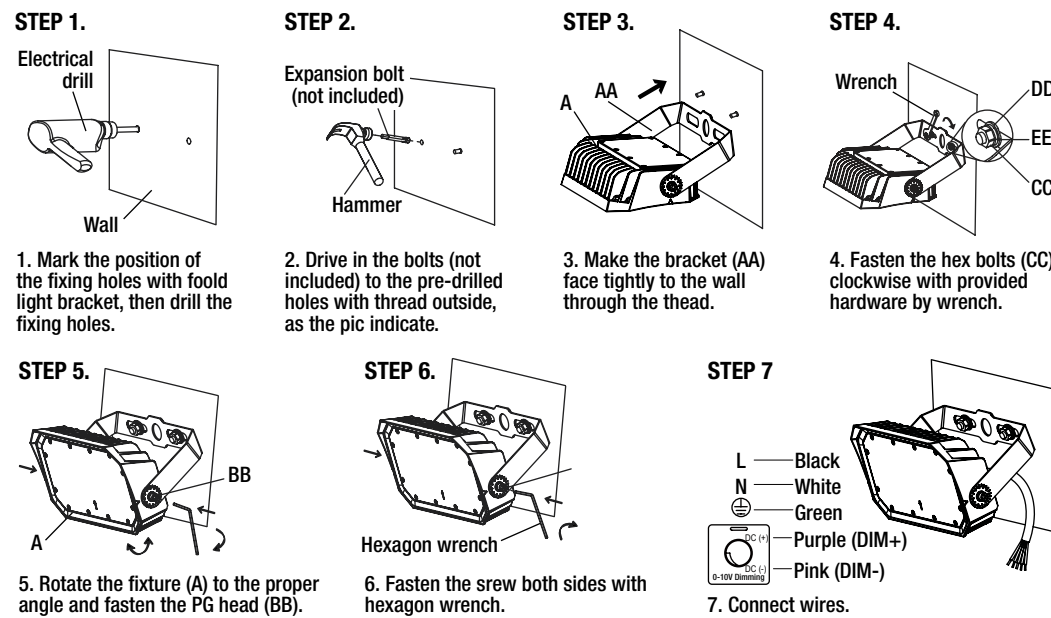

**NOTE:** Photocell have pre-installed with fixture by 12in (Model # 60208161, 60208261) and 14in (Model # 60209161).

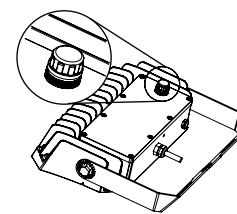

### CARE AND CLEANING

**CAUTION:** Before attempting to clean the tube and luminaire/light fixture, disconnect the power to the fixture by turning the breaker off or removing the fuse from the fuse box. Clean with a soft, dry cloth. Do not use cleaners with chemicals, solvents, or harsh abrasives. Do not use liquid cleaner on the LEDs, LED driver, or wiring.

### TROUBLESHOOTING

Minor problems often can be fixed without the help of an electrician.

**WARNING:** Before doing any work on the fixture, disconnect power to the light fixture.

Problem	Possible Cause	Solution
The fixture will not light.	The power is off.	Ensure the power supply is on.
	The circuit breaker is off.	Ensure the circuit breaker is in the on position.
	There is a bad connection.	Check to ensure proper wire connections are made. Contact a qualified electrician.
	There is a defective switch.	Contact a qualified electrician.
The fuse blows or the circuit breaker trips when the light is turned on.	The wires are crossed or the power wire is grounding out.	Check the wire connections. Contact a qualified electrician or call customer service 1-877-527-0313.

**WARNING:** Carefully read and understand the information given in this manual before beginning the assembly and installation. Failure to do so could lead to electric shock, fire, or other injuries which could be hazardous or even fatal. • Ensure the electricity to the wires you are working on is shut off. Either remove the fuse or turn off the circuit breaker. • To reduce the possibility of serious injury, always take the proper precautions and unplug the fixture before moving or cleaning.

**NOTICE:** This equipment has been tested and found to comply with the limits for a Class B digital device, pursuant to Part 15 of the FCC Rules. These limits are designed to provide reasonable protection against harmful interference in a residential installation. This equipment generates, uses and can radiate radio frequency energy and, if not installed and used in accordance with the instructions, may cause harmful interference to radio communications. However, there is no guarantee that interference will not occur in a particular installation. If this equipment does cause harmful interference to radio or television reception, which can be determined by turning the equipment off and on, the user is encouraged to try to correct the interference by one or more of the following measures: Reorient or relocate the receiving antenna, increase the separation between the equipment and the receiver, connect the equipment into an outlet on a circuit different from that to which the receiver is connected, and consult the dealer or an experienced radio/TV. Changes or modifications not expressly approved by the party responsible for compliance could void the user's authority to operate the equipment.

### WARRANTY

#### WHAT IS COVERED

The manufacturer warrants this lighting fixture to be free from defects in materials and workmanship for a period of five (5) years from date of purchase. This warranty applies only to the original consumer purchaser and only to products used in normal use and service. If this product is found to be defective, the manufacturer's only obligation, and your exclusive remedy, is the repair or replacement of the product at the manufacturer's discretion, provided that the product has not been damaged through misuse, abuse, accident, modifications, alterations, neglect, or mishandling.

#### WHAT IS NOT COVERED

This warranty shall not apply to any product that is found to have been improperly installed, set-up, or used in anyway not in accordance with the instructions supplied with the product. This warranty shall not apply to a failure of the product as a result of an accident, misuse, abuse, negligence, alteration, faulty installation, or any other failure not relating to faulty material or workmanship. This warranty shall not apply to the finish on any portion of the product, such as surface and/or weathering, as this is considered normal wear and tear.

The manufacturer does not warrant and specifically disclaims any warranty, whether express or implied, of fitness for a particular purpose, other than the warranty contained herein. The manufacturer specifically disclaims any liability and shall not be liable for any consequential or incidental loss or damage, including but not limited to any labor / expense costs involved in the replacement or repair of said product.

Contact the Customer Service Team at 1-877-527-0313 or visit [www.HomeDepot.com](http://www.HomeDepot.com).