



# CABANA LOUNGER

Model # 2006539 & 2004573 | Owner's Manual & Assembly Instructions

MANUFACTURED BY:  
Backyard Discovery  
3305 Airport Drive  
Pittsburg, KS 66762  
800-856-4445



2006539 LAGUNA CABANA LOUNGER  
(SPECTRUM INDIGO)



2004573 CATALINA CABANA LOUNGER  
(CAST SLATE)



**INSTALLATION  
SERVICES  
AVAILABLE!\***

*Need a helping hand?*

Let our team of professionals handle the installation for you!

**GOCONFIGURE**  
888-888-5424

\*Installation services are only available  
to U.S. customers.

average 2 person assembly time



assembly time may vary based on skill level

Before you begin

**FOR QUICK &  
EASY ASSEMBLY**

FIND 3D INSTRUCTIONS  
FOR THIS PRODUCT IN

**BILT.**

DOWNLOAD THE FREE APP



For the most up to date assembly manual,  
to register your set, or to order replacement parts please visit  
**[www.backyarddiscovery.com](http://www.backyarddiscovery.com)**

**SAVE THIS ASSEMBLY MANUAL FOR FUTURE REFERENCE IN THE EVENT THAT  
YOU NEED TO ORDER REPLACEMENT PARTS.**

Para obtener instrucciones en español, visite [www.backyarddiscovery.com](http://www.backyarddiscovery.com)



**GOCONFIGURE**  
*Putting it all together for you*

# INSTALLATION SERVICES AVAILABLE!\*

*Need a helping hand?*

Let our team of professionals handle the installation for you!

**GOCONFIGURE**  
**888-888-5424**

*\*Installation services are only available  
to U.S. customers.*

With Go Configure, we bring you 18 years of experience right to your doorstep. We service a wide array of indoor and outdoor recreation products that most consumers don't have the time or ability to deliver & install themselves.

**We do the heavy lifting, so you don't have to!**

- 18+ Years of Experience Servicing Big Box Retailers and Direct Consumers
- Highly Skilled, Specialized, Courteous, Professional Service Technicians
- Over 140,000 Installations Annually
- White Glove Service

- Satisfaction Guarantee
- Flexible Appointments, including weekends
- Coverage across the nation

**Visit [www.goconfigure.com](http://www.goconfigure.com) for more info!**

*\*Installation services are only available to U.S. customers.*



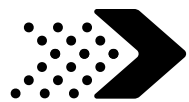

The store where you made your purchase does not stock parts for this item. If you have assembly questions or you are missing or have damaged parts, please call

**1-800-856-4445**

you can also visit [www.backyarddiscovery.com](http://www.backyarddiscovery.com)  
or e-mail [customerservice@backyarddiscovery.com](mailto:customerservice@backyarddiscovery.com)

**Please have the following information ready when you make your call:**

- Model Number of the product located on the front of the assembly manual
  - The item description and number from the parts list from the manual that was included in your box
- 
- Read entire assembly manual, paying special attention to the important tips and safety information.
  - To ensure there are no missing pieces do a complete inventory by first separating and identifying all parts.
  - Make sure to check packing material for small parts that may have fallen out during shipment.
  - Structures are not intended for public use. The Company does not warranty any of its residential structures subjected to commercial use.
  - This manual contains helpful information concerning assembly preparation, installation procedure and required maintenance.
  - Always keep safety in mind as your structure is being built.
  - Keep these instructions for future reference.



Please read entire booklet completely before beginning the assembly process

Please retain these instructions and your receipt for future reference. Keep them in a safe place where you can refer to them as needed. In order to provide you with the most efficient service, it is required that you provide us with the part numbers when ordering parts.

### For Your Records:

Please take time and fill out the information below. This information will be needed for warranty issues.

Where Purchased: \_\_\_\_\_  
 Date of Purchase: \_\_\_\_\_  
 Installation Date: \_\_\_\_\_  
 Installed by: \_\_\_\_\_  
 Tracking Number: \_\_\_\_\_

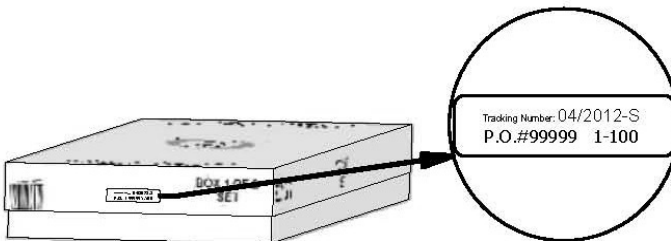

### Tracking Number Reference Label

Tracking ID number on the carton and on the bottom of the vertical ID plate are included for tracking purposes associated with warranty claims.

This Limited Warranty by Backyard Discovery applies to products manufactured under the Backyard Discovery brand or its other brands including but not limited to Backyard Botanical, Adventure Playsets, and Leisure Time Products.

Backyard Discovery warrants that this product is free from defect in materials and workmanship for a period of one (1) year from the original date of purchase. This one (1) year warranty covers all parts including wood, hardware, and accessories. All wood carries a five (5) year pro-rated warranty against rot and decay. Refer to the schedule below for charges associated with replacement of parts under this Limited Warranty. In addition, Backyard Discovery will replace any parts within the first 30 days from date of purchase found to be missing from or damaged in the original packaging.

This warranty applies to the original owner and registrant and is non-transferable. Regular maintenance is required to assure maximum life and performance of this product. Failure by the owner to maintain the product according to the maintenance requirements may void this warranty. Maintenance guidelines are provided in the Owner's Manual.

This Limited Warranty does not cover:

- Installation
- Labor for any inspection
- Labor for replacement of any defective item(s)
- Incidental or consequential damages
- Cosmetic defects which do not affect performance or integrity of a part or the entire product
- Vandalism, improper use, failure due to loading or use beyond the capacities stated in the applicable Assembly Manual.
- Acts of nature including but not limited to wind, storms, hail, floods, excessive water exposure
- Improper installation including but not limited to installation on uneven, unlevel, or soft ground
- Minor twisting, warping, checking, or any other natural occurring properties of wood that do not affect performance or integrity

Backyard Discovery products have been designed for safety and quality. Any modifications made to the original product could damage the structural integrity of the unit leading to failure and possible injury. Modification voids any and all warranties and Backyard Discovery assumes no liability for any modified products or consequences resulting from failure of a modified product.

This product is warranted for RESIDENTIAL USE ONLY. Under no circumstance should a Backyard Discovery product be used in public settings. Such use may lead to product failure and potential injury. Any and all public use will void this warranty. Backyard Discovery disclaims all other representations and warranties of any kind, express or implied.

### Pro Rated Part Replacement Schedule

<u>Product Age</u>	<u>Customer Pays</u>
<b>All Parts</b>	
0-30 days from date of purchase	\$0 and free shipping
31 days to 1 year	\$0 + S&H
<b>Wood Rot and Decay Only</b>	
1 year	\$0 and free shipping
2 year	20% + S&H
3 year	40% + S&H
4 year	60% + S&H
5 year	80% + S&H
Over 5 years	100% + S&H



# WARNING

**IT IS IMPORTANT TO CHECK AND TIGHTEN ALL HARDWARE AT THE BEGINNING AND DURING THE SEASON AS THEY MAY LOOSEN DUE TO WOOD EXPANSION AND CONTRACTION.**

- **DO NOT climb or walk on the roof for any reason**
- **Requires two or more people to assemble safely**
- **Check for underground utilities before digging or driving stakes into the ground.**
- **Check carefully for overhead lines and ensure there is at least 6'-7" (2m) clearance from any overhead electrical wires.**
- **Permanent structures may require a building permit. As the purchaser and or installer of this product you are advised to consult local planning, zoning and building inspection departments for guidance on applicable building codes and/or zoning requirements.**
- Wood is NOT flame retardant and will burn. Grills, fire pits and chimineas are a fire hazard if placed too close to your structure.
- Wear gloves to avoid injury during installation.
- During installation, follow all safety warnings provided with your tools and use safety glasses.
- Check all nuts and bolts twice monthly during the usage season and tighten as required. (But not so tight that you crack the wood) It is particularly important that this procedure be followed at the beginning of each season.
- Oil all metallic moving parts monthly during the usage period.
- Check all coverings for bolts and sharp edges twice monthly during usage season to be certain they are in place. Replace when necessary. It is especially important to do this at the beginning of each new season.
- For rusted areas on metallic members such as hinges, brackets, etc. sand and repaint, using a non lead-based paint meeting the requirements of Title 16 CRF Part 1303.
- Inspect wood parts monthly. The grain of the wood sometimes will lift in the dry season causing splinters to appear. Light sanding may be necessary to maintain a safe environment. Treating your Product with protection (sealant) after sanding will help prevent severe checking/splitting and other weather damage.
- We have applied a waterborne translucent stain to your unit. This is done for color only. Once or twice a year, depending on your climate conditions, you must apply some type of protection (sealant) to the wood of your unit. Prior to the application of sealant, lightly sand any "rough" spots on your set. Please note this is a requirement of your warranty.

**OWNERS SHALL BE RESPONSIBLE FOR MAINTAINING THE LEGIBILITY OF THE WARNING LABELS**



***Your Backyard Discovery structure is designed and constructed of quality materials. As with all outdoor products it will weather and wear. To maximize the enjoyment, safety and life of your structure it is important that you properly maintain it.***

---

### About Our Wood

Backyard Discovery uses 100% Cedar (C. Lanceolata) wood. Although we take great care in selecting the best quality lumber available, wood is still a product of nature and susceptible to weathering which can change the appearance of your set.

#### **What causes weathering? Does it affect the strength of my product?**

One of the main reasons for weathering is the effects of water (moisture); the moisture content of the wood at the surface is different than the interior of the wood. As the climate changes, moisture moves in or out of the wood, causing tension which can result in checking and or warping. You can expect the following due to weathering. These changes will not affect the strength of the product:

**1. Checking** is surface cracks in the wood along the grain. A post (4" x 4") will experience more checking than a board (1" x 4") because the surface and interior moisture content will vary more widely than in thinner wood.

**2. Warping** results from any distortion (twisting, cupping) from the original plane of the board and often happens from rapid wetting and drying of the wood.

**3. Fading** happens as a natural change in the wood color as it is exposed to sun-light and will turn grey over time.

#### **How can I reduce the amount of weathering to wood product?**

**1.** Your wood product is coated with a water-based stain. Sunlight will break down the coating, so we recommend applying a water repellent or stain on a yearly basis (see your local stain and paint supplier for a recommended product). You must apply some type of protection (sealant) to the wood of your product. **Please note this is a requirement of your warranty.** Most weathering is just the normal result of nature and will not affect safety. However if you are concerned that a part has experienced a severe weathering problem please call our customer service department for further assistance.

**2.** Inspect wood parts monthly. The grain of the wood sometimes will lift in the dry season causing splinters to appear. Light sanding may be necessary to maintain a safe environment. Treating your Product with protection (sealant) after sanding will help prevent severe checking/ splitting and other weather damage.



### Protrusion Hazard

### Incorrect

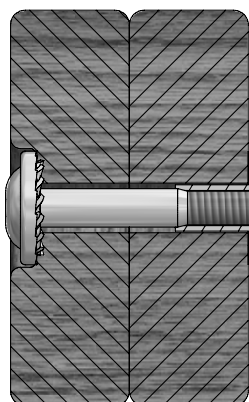

If you see exposed threads and your bolt protrudes beyond the T-Nut you may have over tightened the bolt. To eliminate this, remove the bolt and add washers to eliminate the problem.

### Correct

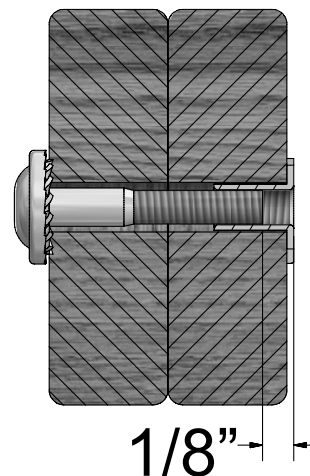

## Proper Hardware Assembly

### Bolt and T-Nut Assembly

Tap T-nut into the provided hole. Insert your bolt through the lock washer and insert into the provided hole opposite from the T-Nut. Turn clockwise to thread into T-nut. Do not completely tighten until instructed.

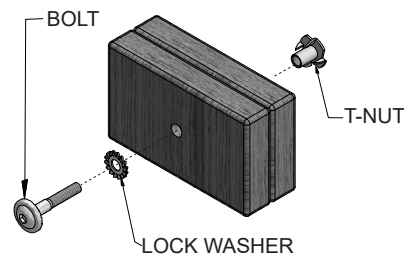

### Bolt and Barrel Nut Assembly

Insert barrel nut through the lock washer and press the pair through the provided hole. Insert your bolt through the second lock washer and insert the pair into the provided hole opposite from the barrel nut. Turn clockwise to thread into the barrel nut. Do not completely tighten until instructed.

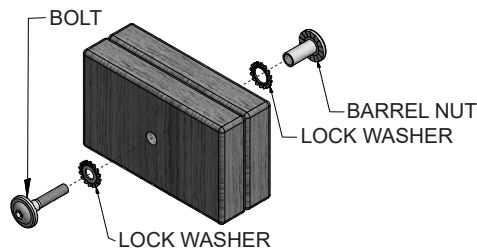

### Lag Assembly

Normally there will be a pre-drilled pilot hole on assemblies that require a Lag Screw. If there is no pilot hole, line up the two boards as they are to be attached and use the factory drilled hole as a guide to drill another pilot hole into the adjoining board. This will keep the wood from splitting. Only a lock washer is required for steps with Lag Screws.

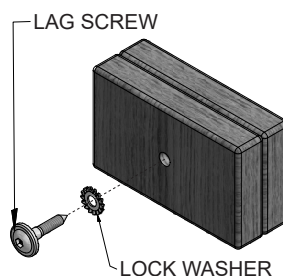



### ASSEMBLY TIP:

Keep an eye out for these boxes which will contain helpful pictures and information making the assembly process as quick and painless as possible.

## Sorting Wood

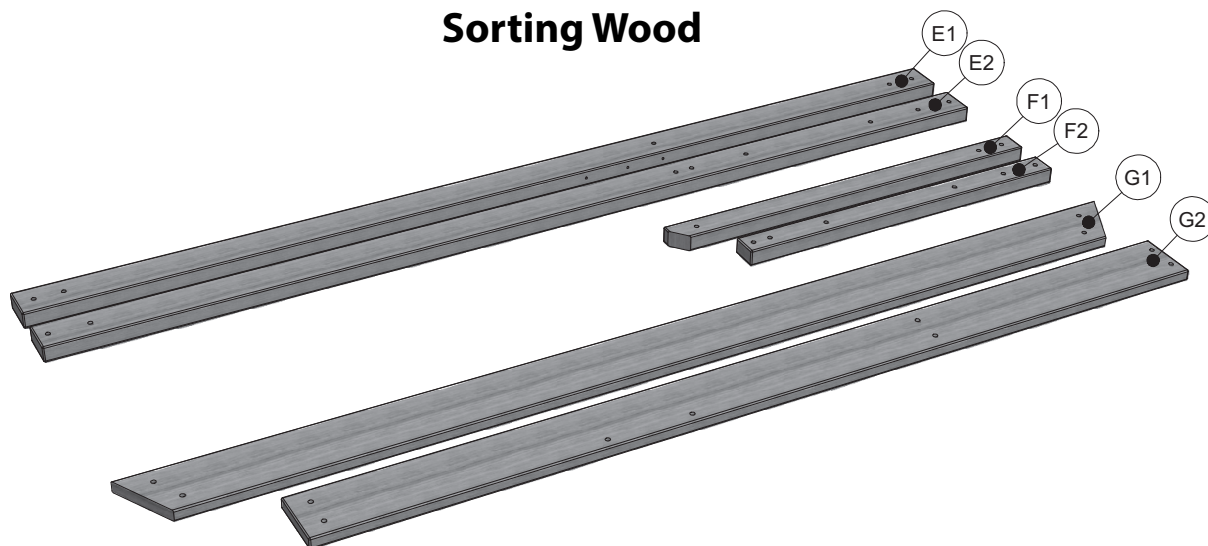

When removing the wood from the boxes we recommend arranging them by part number before you begin assembly. This will allow for faster assembly and easily identify any parts that may be missing or damaged.

## Sorting Hardware

**NUT BARREL**  
H100545



**SCREW**  
H100695



**T-NUT**  
H100699



**WASHER FLAT**  
H100706



**BOLT HEX**  
H100716



**BOLT**  
H100718

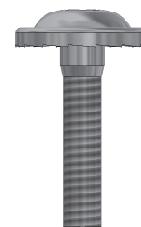

**SCREW PWH**  
H100742



To help with assembly we recommend sorting your hardware bags with the seven digit alpha-numeric number printed on the bags or by hardware type (i.e. bolts, nuts, etc.). Organizing your hardware will make assembly easier.

## Hardware Identification

Hardware bags are printed with a seven digit alpha-numeric part number. During assembly you only need to reference the last three digits of the part number as noted in each step. This will make finding the correct hardware easier.

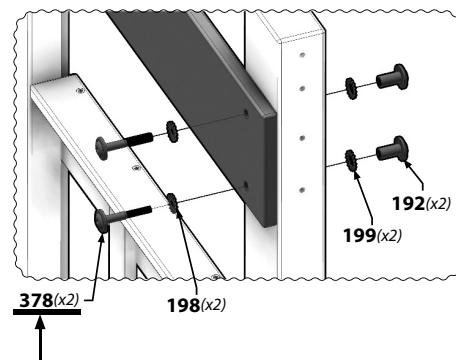
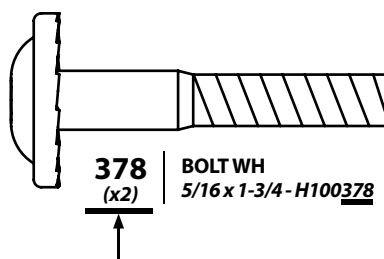

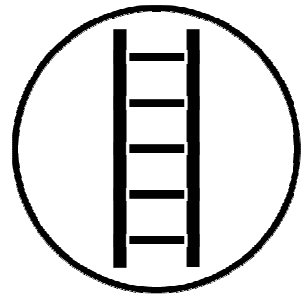
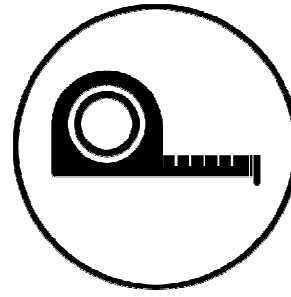
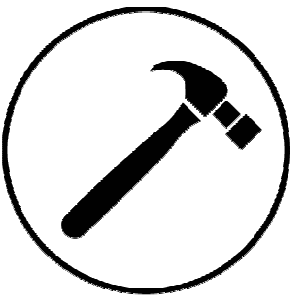
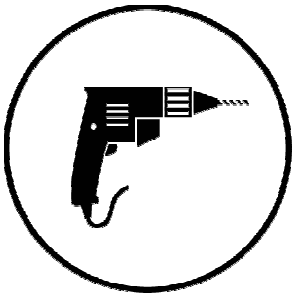
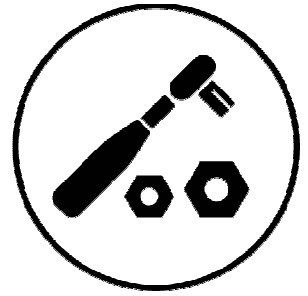
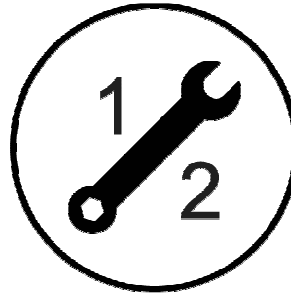
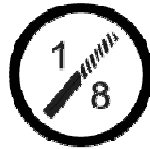
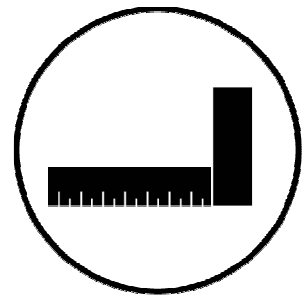
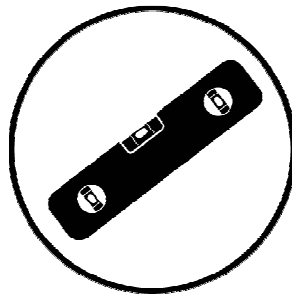

Icons and their uses you will see throughout this manual



You will need to make sure that your assembly is square before tightening your bolts.



When you see this icon you will need a socket wrench. The icons below show the size of attachments needed for assembly 1/2.



For proper assembly you will need to ensure that your structure is level before proceeding to the next step.

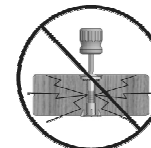

This icon warns you to not over tighten your bolts. This is to prevent structural damage and also splintering your wood.



Some steps in the assembly process will require an extra set of hands. Make sure you have a helper available.



This icon shows the size of an open ended wrench. Using the wrench as the fraction bar.

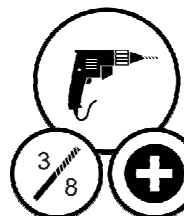

This icon will show you what drill attachments are needed. For this example you will need a Phillips head attachment and 3/8 socket.



**It is critically important that you start with square and level footings, concrete pad or deck to attach your structure**

- Pay close attention to the items needed for each step. Make sure you are using the correct hardware for each step. Using incorrect hardware may result in improper assembly
- Remember to double check for underground utilities and overhead electrical lines

**Post mounts are provided with your structure which allows you to permanently install your structure to a pre-existing or new wood or concrete surface.**

- The hardware to attach the post mounts to the structure is included.
- The hardware to mount the structure permanently to a concrete surface is included.
- The hardware to mount the structure permanently to a wood deck is NOT included and will need to be purchased separately. You must ensure there is ample structural support under the deck before permanently attaching.

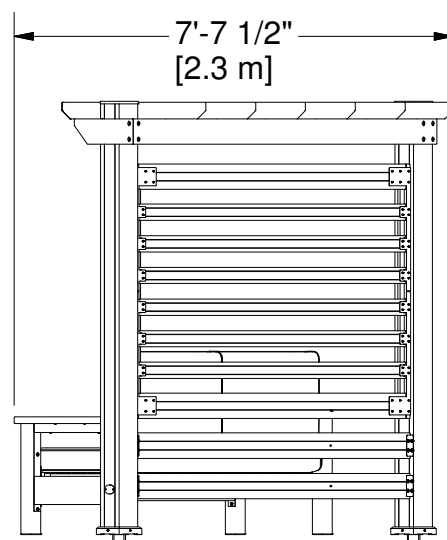
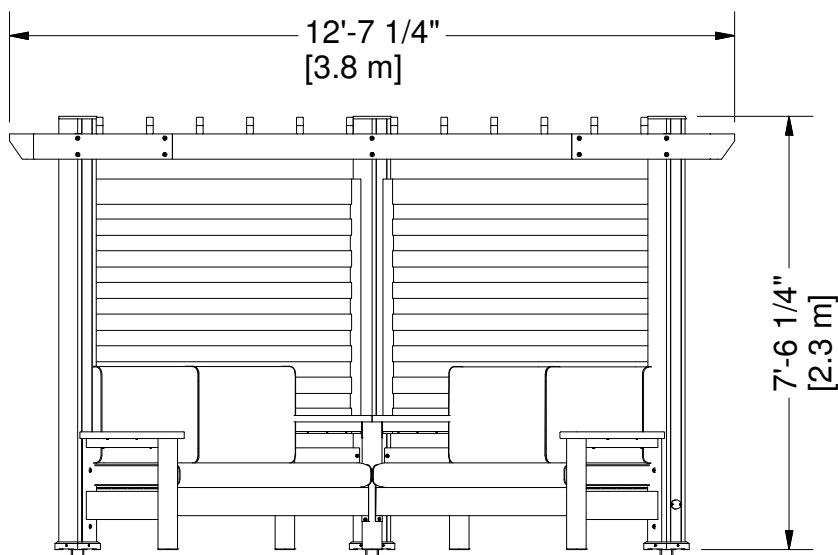
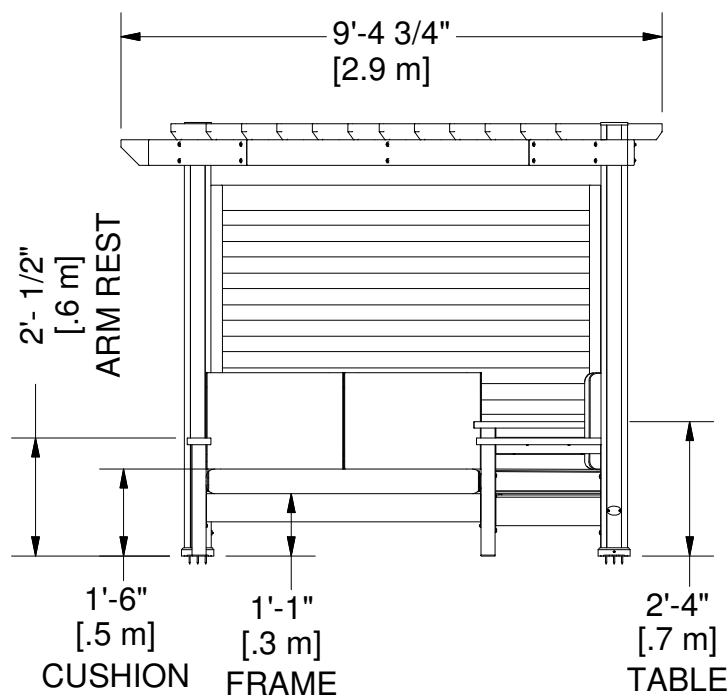
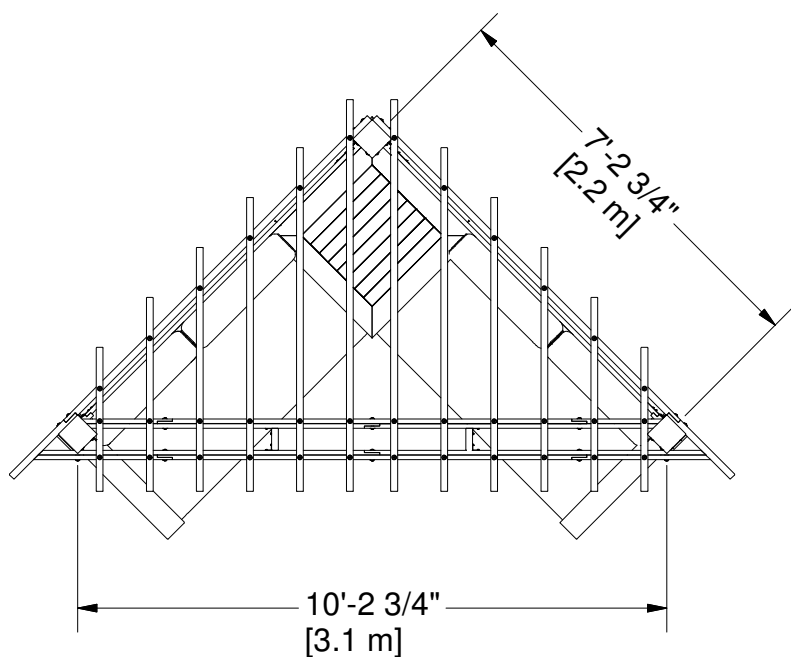





Wood Components (Not to Scale)



**D1 | JOIST - W4L13040**  
(1) | 1 3/8"x5 1/4"x89 1/2" (36x134x2274)



**D2 | JOIST - W4L13041**  
(1) | 1 3/8"x5 1/4"x89 1/2" (36x134x2274)



**D3 | JOIST END - W4L13042**  
(1) | 1 3/8"x5 1/4"x18 3/4" (36x134x477)



**D4 | JOIST END - W4L13043**  
(1) | 1 3/8"x5 1/4"x18 3/4" (36x134x477)



**G7 | BEAM END - W4L13048**  
(1) | 1"x5 1/4"x29" (24x134x736)

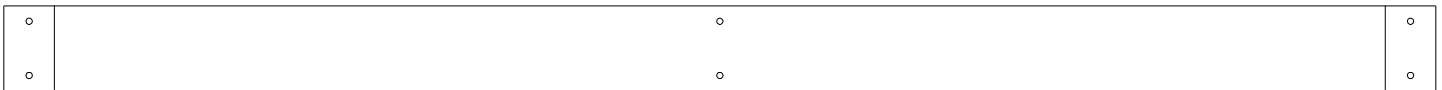

**G8 | BEAM - W4L13049**  
(2) | 1"x5 1/4"x89 1/2" (24x134x2274)



**G10 | BEAM - W4L13051**  
(1) | 1"x5 1/4"x71 1/8" (24x134x1807)



**G11 | BEAM END - W4L13052**  
(1) | 1"x5 1/4"x19" (24x134x484)



**G12 | BEAM - W4L13053**  
(1) | 1"x5 1/4"x61 1/4" (24x134x1555)



## Wood Components (Not to Scale)



**G13** | BEAM - W4L13054  
(1) | 1"x5 1/4"x61 1/4" (24x134x1555)



**D5** | SUPPORT BRACE - W4L13055  
(2) | 1 3/8"x5 1/4"x4 5/8" (36x134x116)



**G14** | BEAM END - W4L13062  
(1) | 1"x5 1/4"x29" (24x134x736)



**G15** | BEAM END - W4L13063  
(1) | 1"x5 1/4"x19" (24x134x484)



**G9** | BEAM - W4L13050  
(1) | 1"x5 1/4"x71 1/8" (24x134x1807)

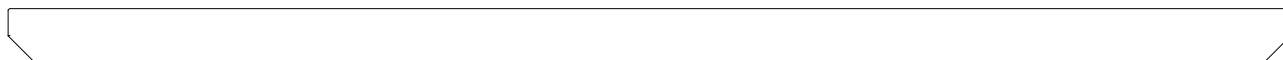

**E1** | TOP JOIST - W4L13056  
(2) | 1 3/8"x3 3/8"x81 1/2" (36x86x2070)



**E2** | TOP JOIST - W4L13057  
(2) | 1 3/8"x3 3/8"x71 1/2" (36x86x1817)



**E3** | TOP JOIST - W4L13058  
(2) | 1 3/8"x3 3/8"x61 1/8" (36x86x1553)



**E4** | TOP JOIST - W4L13059  
(2) | 1 3/8"x3 3/8"x50 3/4" (36x86x1289)



Wood Components (Not to Scale)



**E5** | TOP JOIST - W4L13060  
(2) | 1 3/8"x3 3/8"x40 3/8" (36x86x1025)

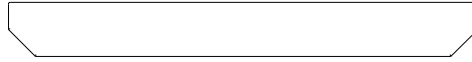

**E6** | TOP JOIST - W4L13061  
(2) | 1 3/8"x3 3/8"x30" (36x86x761)



**F1** | CLEAT - W4L13044  
(4) | 1 3/8"x2 3/8"x53" (36x60x1345)



**G1** | RAIL - W4L13045  
(1) | 1"x5 1/4"x78 7/8" (24x134x2002)



**G2** | TOP RAIL - W4L13047  
(2) | 1"x5 1/4"x78 7/8" (24x134x2002)

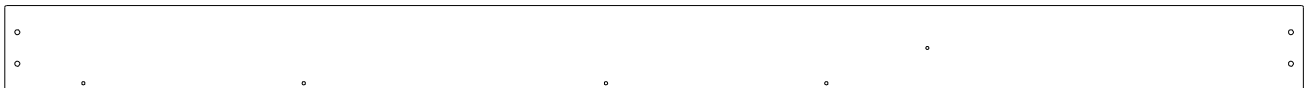

**G3** | TOP RAIL - W4L13064  
(1) | 1"x5 1/4"x81 1/4" (24x134x2063)



**G4** | RAIL - W4L13065  
(1) | 1"x5 1/4"x78 7/8" (24x134x2002)

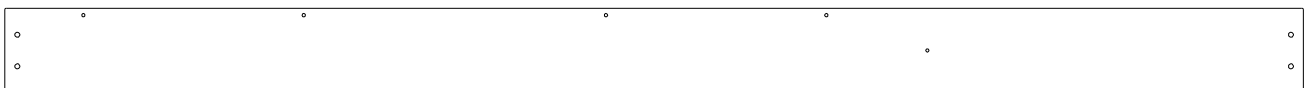

**G5** | TOP RAIL - W4L13066  
(1) | 1"x5 1/4"x81 1/4" (24x134x2063)

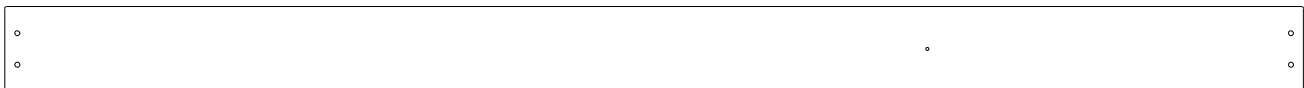

**G6** | RAIL - W4L13067  
(2) | 1"x5 1/4"x81 1/4" (24x134x2063)



**H1** | RAIL - W4L13046  
(12) | 1"x3 3/8"x78 7/8" (24x86x2002)



Wood Components (Not to Scale)

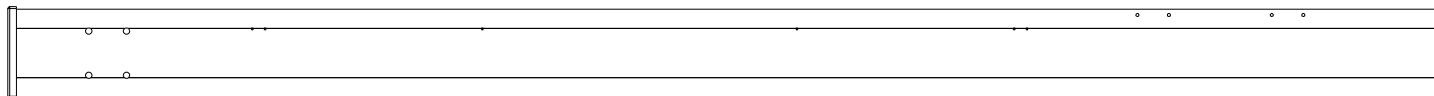

**WP1** | PERGOLA POST - W2A02922  
(1) | 5 1/2"x5 1/2"x89 1/2" (140x140x2274)

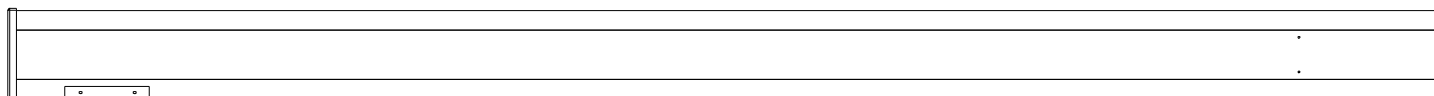

**WP2** | PERGOLA POST - W2A02923  
(1) | 5 1/2"x5 1/2"x89 1/2" (140x140x2274)

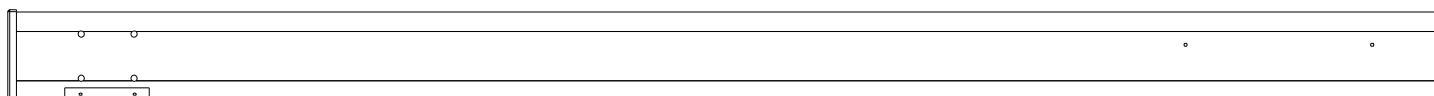

**WP3** | PERGOLA POST - W2A02924  
(1) | 5 1/2"x5 1/2"x89 1/2" (140x140x2274)



Wood Components (Not to Scale)

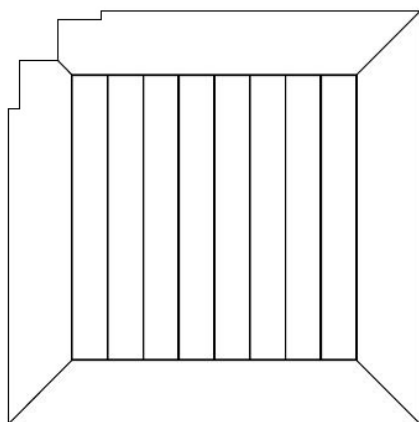

**TT1** | TABLE TOP - W2A02925  
(1) | 1 5/16"x30 1/8"x30 1/8" (34x765x765)

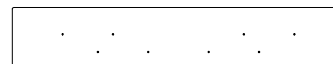

**D7** | ARM REST - W4L13068  
(2) | 1 3/8"x5"x26" (36x126x660)



Hardware Components



H100387 | SCREW PFH BLK  
(68) | 8x1-1/4



H100200 | SCREW PFH BLK  
(13) | 8x1 1/2



H100391 | SCREW PFH BLK  
(26) | 8x2



H100120 | SCREW CONCRETE ANCHOR  
(13) | 1/4x2



H100486 | BOLT WH BLK  
(18) | 1/4x5/8



H100403 | LAG SCREW WH BLK  
(18) | 1/4x1 1/2



H100407 | BOLT WH BLK  
(13) | 5/16x1-1/2

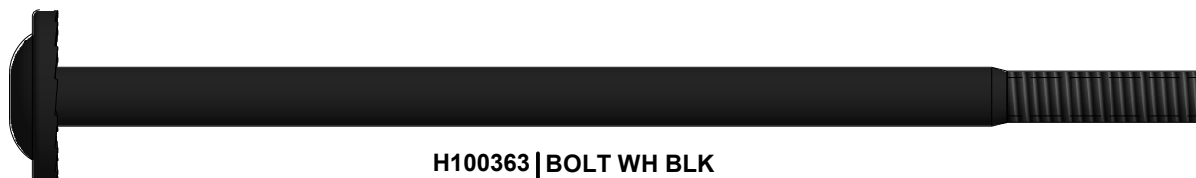

H100363 | BOLT WH BLK  
(18) | 5/16X6



H100202 | SCREW PWH BLK  
(164) | 8x5/8



H100392 | SCREW PWH BLK  
(4) | 8x3/4

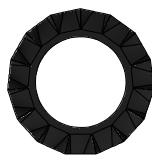

H100199 | WASHER LOCK EXT BLK  
(30) | 12x19

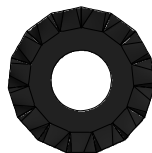

H100198 | WASHER LOCK EXT BLK  
(76) | 8x19

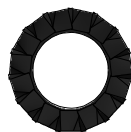

H100400 | WASHER LOCK EXT BLK  
(17) | 8x15



H100399 | NUT BARREL WH BLK  
(18) | 1/4x7/8

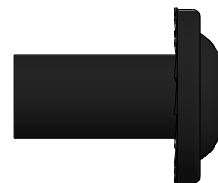

H100192 | NUT BARREL WH BLK  
(13) | 5/16x7/8



H100193 | NUT BARREL WH BLK  
(18) | 5/16x1-1/2



Hardware Components



H100197 | LAG SCREW WH BLK  
(4) | 5/16x2 1/2



H100206 | LAG SCREW WH  
(4) | 5/16x3



H100825 | LAG SCREW  
(38) | 5/16x4 BLK



H100764 | SCREW SETTER  
(1)



A100042 | TORX BIT  
(2) | T-40



H100147 | TORX BIT  
(2) | T-30

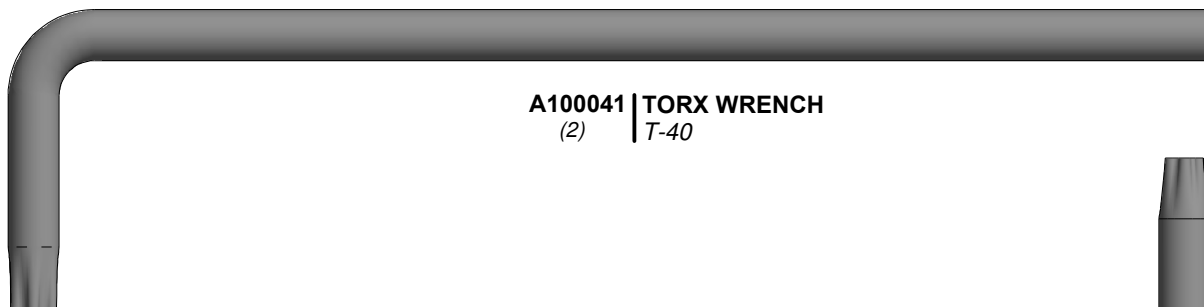

A100041 | TORX WRENCH  
(2) | T-40



H100114 | TORX WRENCH  
(2) | T-30



Accessory Components (Not to Scale)

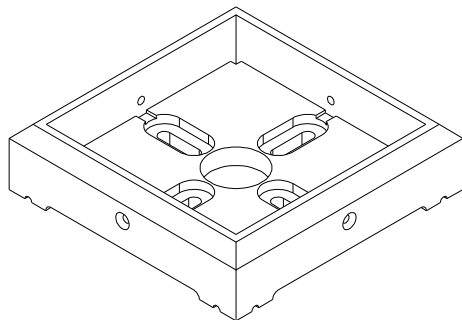

A100029 | FOOT 142 SQUARE POST  
(3)



A100241 | BYD ID TAG (SMALL) WITHOUT AGES  
(1)

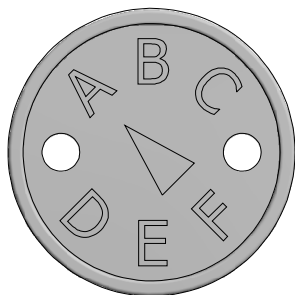

A100314 | "A" REVISION TAG  
(1)

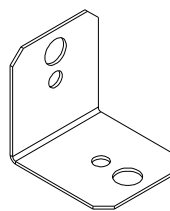

A4M00555 | 90° L-BRACKET - BLK  
(8)

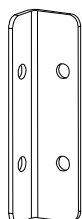

A4M01108 | L BRACKET 24x30x112 - BLK  
(8)

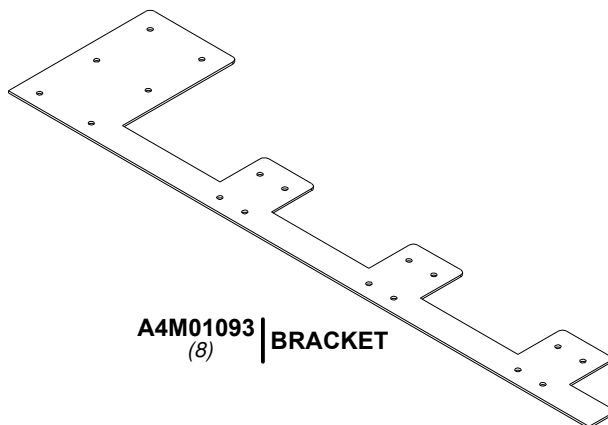

A4M01093 | BRACKET  
(8)

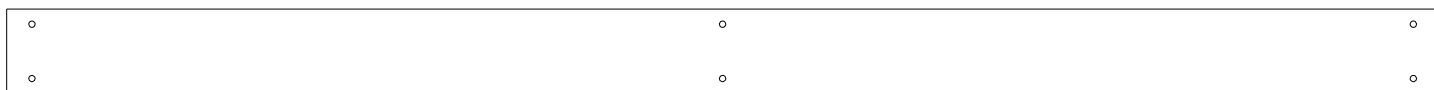

A4M01111 | METAL BEAM  
(2)



Accessory Components (Not to Scale)

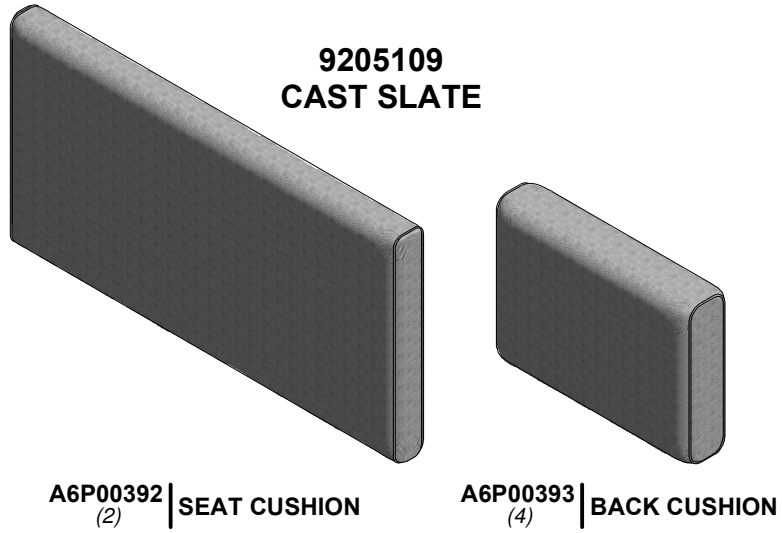

OR

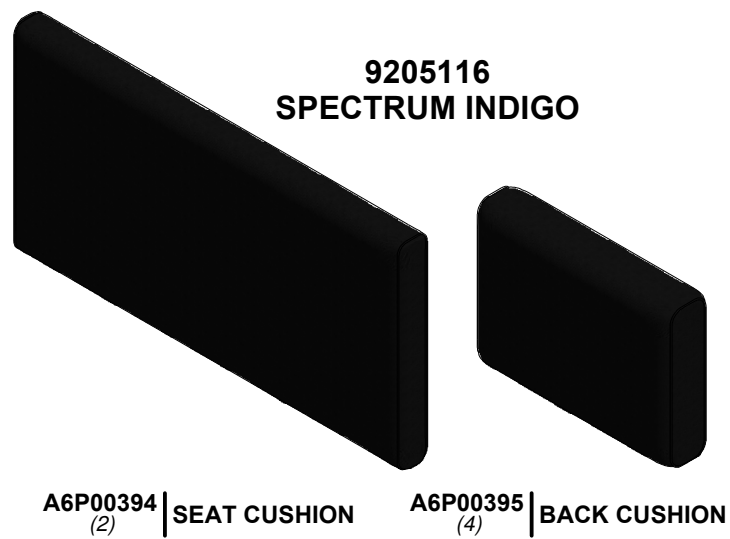





Accessory Components (Not to Scale)

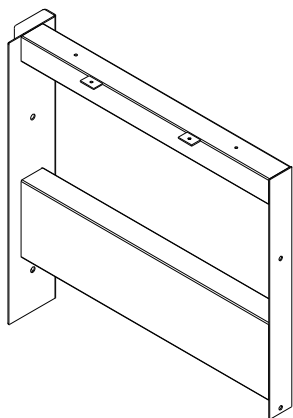

A4M01060 (1) | FRAME END - LEFT

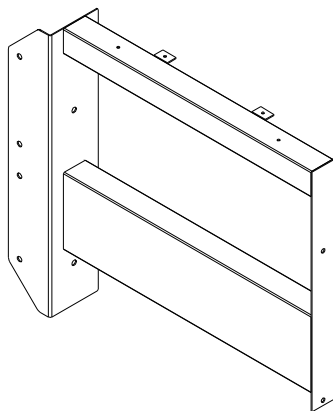

A4M01066 (1) | FRAME END - RIGHT

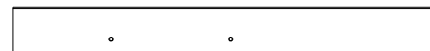

A4M01063 (1) | POST

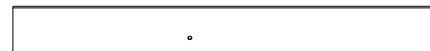

A4M01069 (1) | POST



A4M01070 (1) | POST

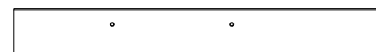

A4M01105 (1) | ARM POST - RIGHT



A4M01106 (1) | ARM POST - LEFT

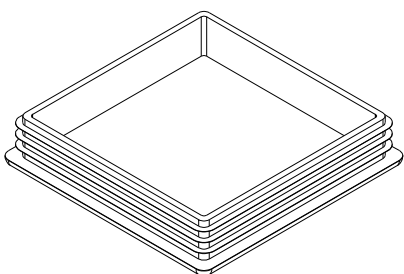

A6P00377 (5) | SNAP-IN SQUARE PLUG

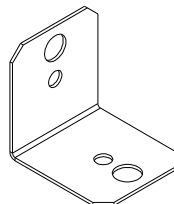

A4M00555 (2) | 90° L-BRACKET - BLK

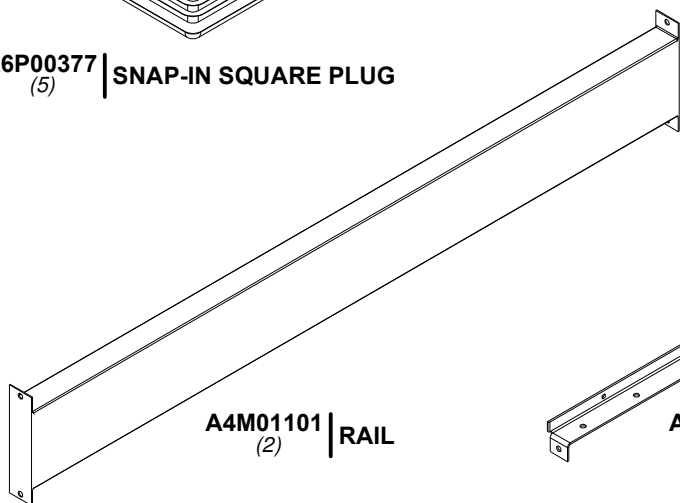

A4M01101 (2) | RAIL

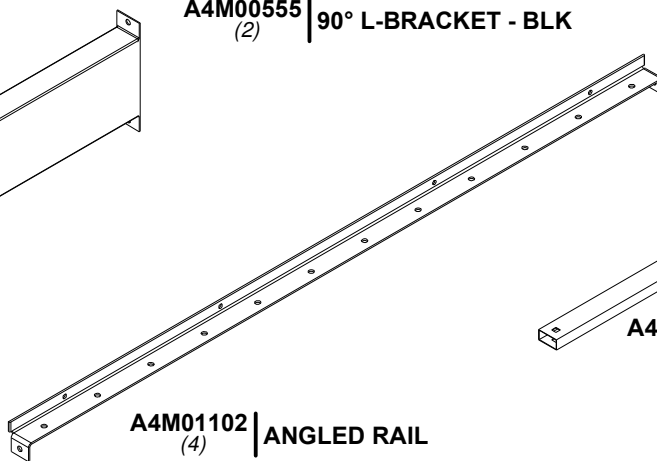

A4M01102 (4) | ANGLED RAIL

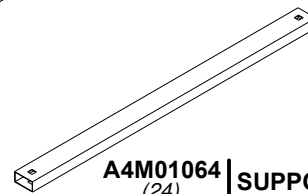

A4M01064 (24) | SUPPORT

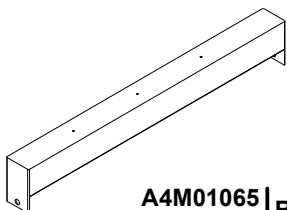

A4M01065 (2) | RAIL

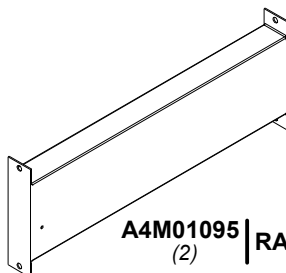

A4M01095 (2) | RAIL



Hardware Components



H100712 | BOLT CARRIAGE BLK  
(50) | 5/16x1 1/2

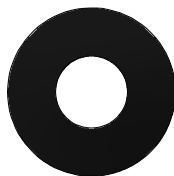

H100770 | WASHER FLAT  
(52) | 5/16 BLK

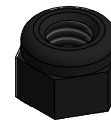

H100479 | NUT LOCK BLK  
(50) | 5/16



H100471 | LAG SCREW WH BLK  
(11) | 5/16x1 1/2



H100171 | BOLT WH BLK  
(38) | 1/4x1

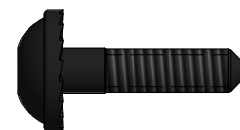

H100460 | LAG SCREW WH BLK  
(11) | 1/4x1



H100824 | SCREW PWH BLK  
(11) | 8x3



H100392 | SCREW PWH BLK  
(4) | 8x3/4



H100202 | SCREW PWH BLK  
(4) | 8x5/8



H100391 | SCREW PFH BLK  
(7) | 8x2



# STEP 1

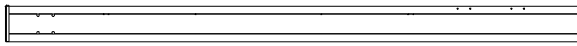

**WP1 PERGOLA POST - W2A02922**  
(1) 5 1/2"x5 1/2"x89 1/2" (140x140x2274)

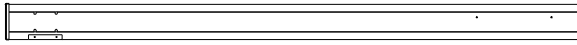

**WP3 PERGOLA POST - W2A02924**  
(1) 5 1/2"x5 1/2"x89 1/2" (140x140x2274)



**D2 JOIST - W4L13041**  
(1) 1 3/8"x5 1/4"x89 1/2" (36x134x2274)

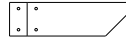

**D4 JOIST END - W4L13043**  
(1) 1 3/8"x5 1/4"x18 3/4" (36x134x477)

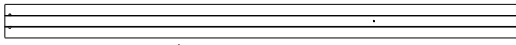

**G5 TOP RAIL - W4L13066**  
(1) 1"x5 1/4"x81 1/4" (24x134x2063)

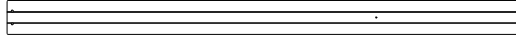

**G6 RAIL - W4L13067**  
(1) 1"x5 1/4"x81 1/4" (24x134x2063)



**A4M01108 L BRACKET 24x30x112 - BLK**  
(4)



**H100486 BOLT WH BLK**  
(8) 1/4x5/8



**H100400 WASHER LOCK EXT BLK**  
(8) 8x15



**H100399 NUT BARREL WH BLK**  
(8) 1/4x7/8



**H100403 LAG SCREW WH BLK**  
(8) 1/4x1 1/2



**H100363 BOLT WH BLK**  
(8) 5/16x6



**H100198 WASHER LOCK EXT BLK**  
(8) 8x19



**H100199 WASHER LOCK EXT BLK**  
(8) 12x19



**H100193 NUT BARREL WH BLK**  
(8) 5/16x1-1/2



### ASSEMBLY TIP:

FOR EASE OF ASSEMBLY WE RECOMMEND USING SAW HORSES FOR THIS STEP.

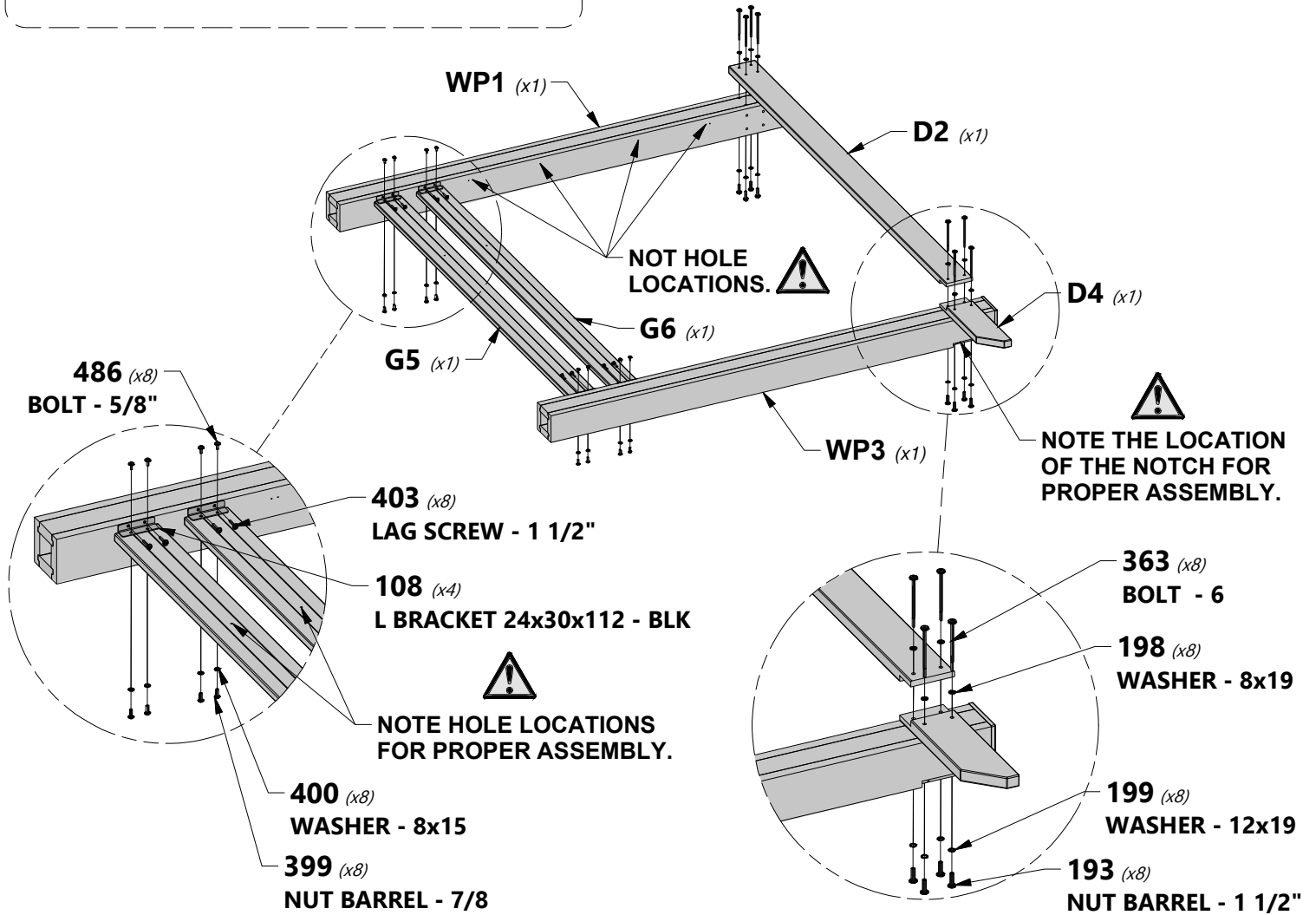



# STEP 2

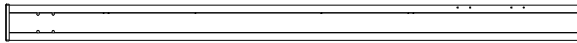

**WP2 PERGOLA POST - W2A02923**  
(1) 5 1/2"x5 1/2"x89 1/2" (140x140x2274)



**D1 JOIST - W4L13040**  
(1) 1 3/8"x5 1/4"x89 1/2" (36x134x2274)

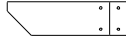

**D3 JOIST END - W4L13042**  
(1) 1 3/8"x5 1/4"x18 3/4" (36x134x477)

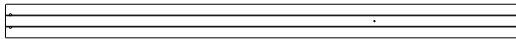

**G3 TOP RAIL - W4L13064**  
(1) 1"x5 1/4"x81 1/4" (24x134x2063)



**G6 RAIL - W4L13067**  
(1) 1"x5 1/4"x81 1/4" (24x134x2063)



**A4M01108 L BRACKET 24x30x112 - BLK**  
(4)



**H100486 BOLT WH BLK**  
(8) 1/4x5/8



**H100400 WASHER LOCK EXT BLK**  
(8) 8x15



**H100399 NUT BARREL WH BLK**  
(8) 1/4x7/8



**H100403 LAG SCREW WH BLK**  
(8) 1/4x1 1/2



**H100363 BOLT WH BLK**  
(8) 5/16x6



**H100198 WASHER LOCK EXT BLK**  
(8) 8x19



**H100199 WASHER LOCK EXT BLK**  
(8) 12x19



**H100193 NUT BARREL WH BLK**  
(8) 5/16x1-1/2



**193 (x8) NUT BARREL - 1 1/2"**

**199 (x8) WASHER - 12x19**



**NOTE THE LOCATION OF THE NOTCH FOR PROPER ASSEMBLY.**

**WP2 (x1) PERGOLA POST**

**400 (x8) WASHER - 8x15**  
**399 (x8) NUT BARREL - 7/8**

**363 (x8) BOLT - 6**

**198 (x8) WASHER - 8x19**



**NOTE HOLE LOCATIONS FOR PROPER ASSEMBLY.**

**486 (x8) BOLT - 5/8"**

**403 (x8) LAG SCREW - 1 1/2"**

**108 (x4) L BRACKET 24x30x112 - BLK**

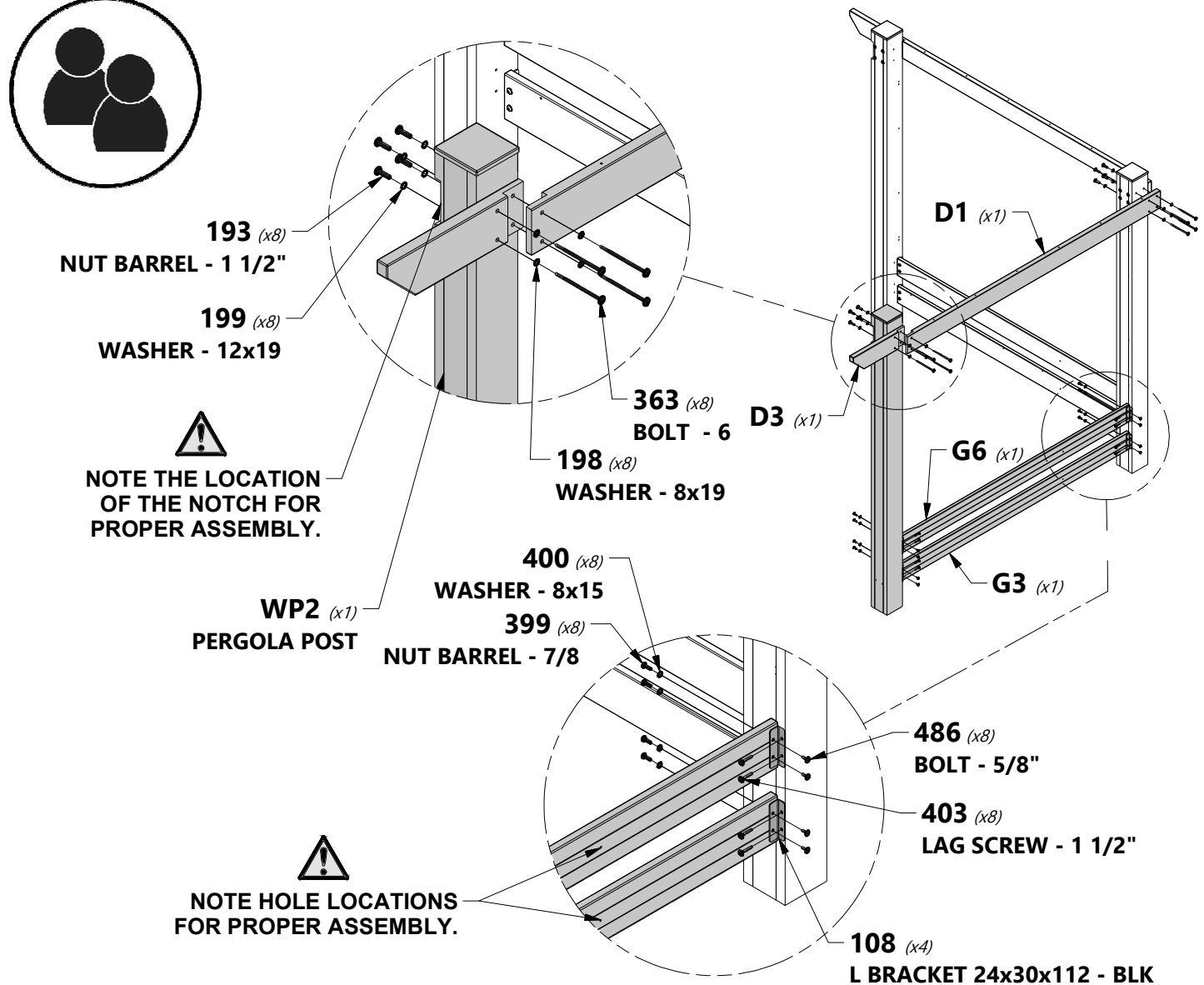



# STEP 3

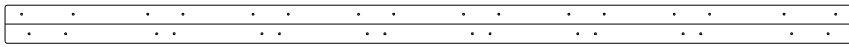

**F1 | CLEAT - W4L13044**  
(4) | 1 3/8"x2 3/8"x53" (36x60x1345)



**H100391 | SCREW PFH BLK**  
(24) | 8x2



NOTE DIRECTION  
OF THE NOTCH.



LOCATE AND ALIGN  
WITH PILOT HOLES FOR  
PROPER ASSEMBLY.

**391 (x24)**  
SCREW - 2"

**F1 (x4)**

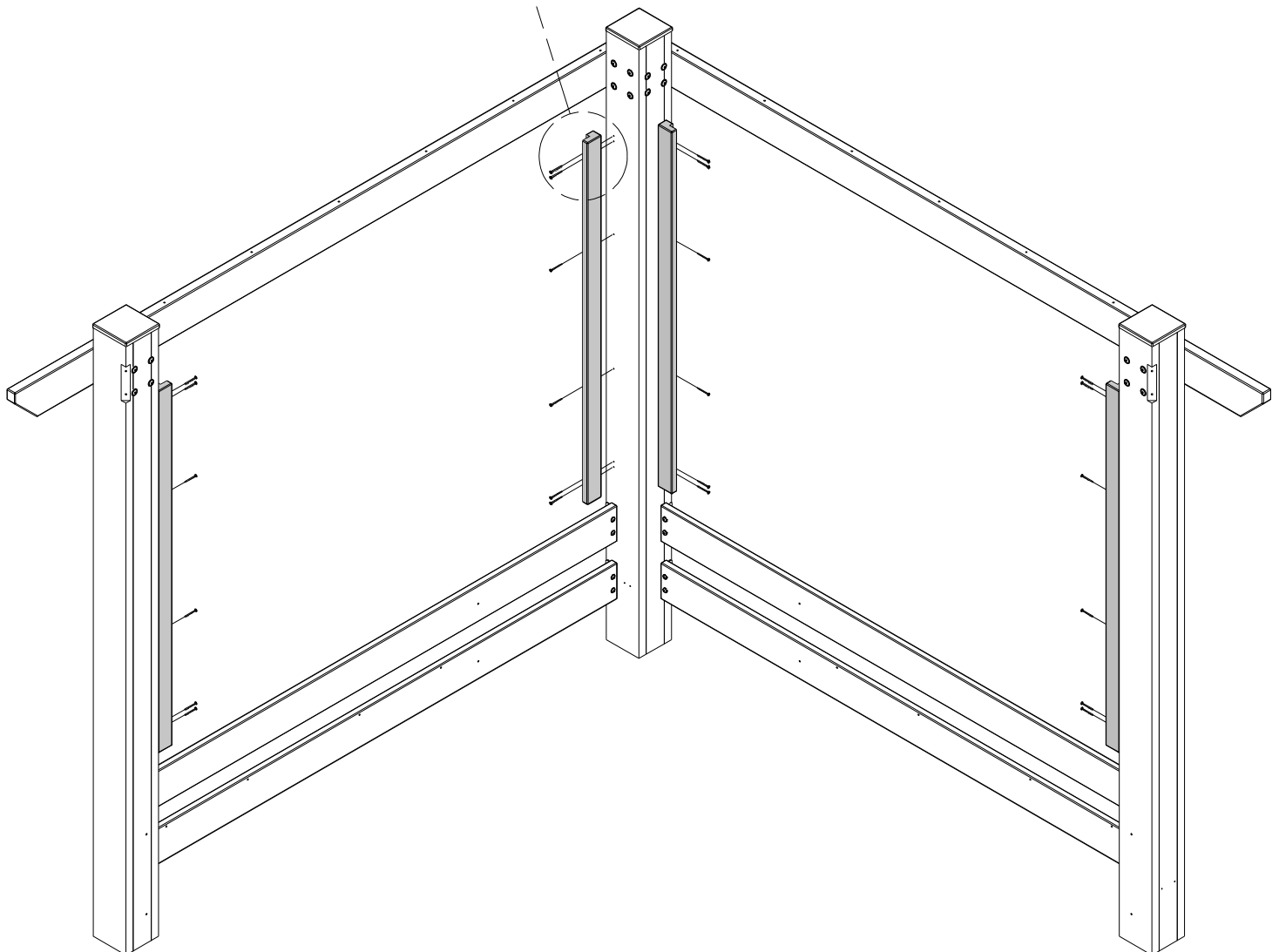



# STEP 4



**G1** | RAIL - W4L13045  
(1) | 1"x5 1/4"x78 7/8" (24x134x2002)



**G2** | TOP RAIL - W4L13047  
(2) | 1"x5 1/4"x78 7/8" (24x134x2002)



**G4** | RAIL - W4L13065  
(1) | 1"x5 1/4"x78 7/8" (24x134x2002)

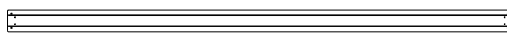

**H1** | RAIL - W4L13046  
(12) | 1"x3 3/8"x78 7/8" (24x86x2002)



**H100387** | SCREW PFH BLK  
(64) | 8x1-1/4

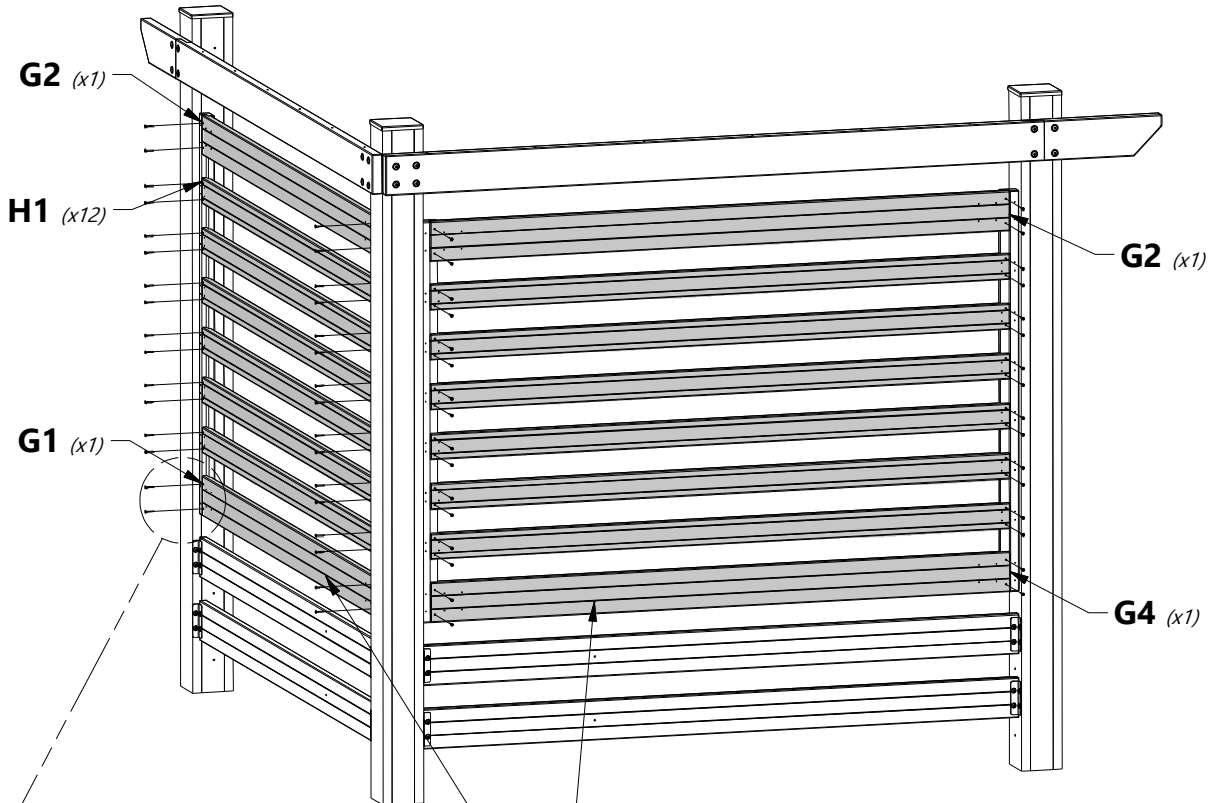

**NOTE HOLE LOCATION FOR PROPER ASSEMBLY.**

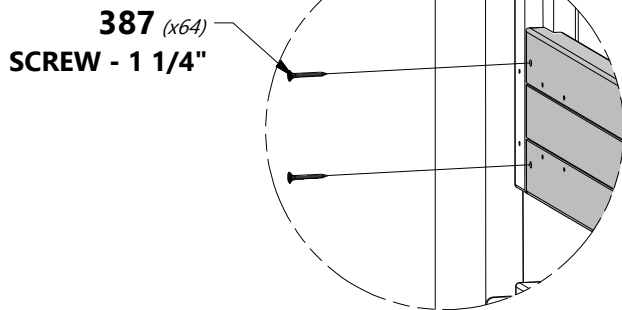



# STEP 5

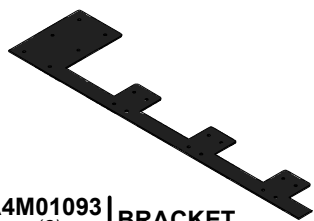

**A4M01093** | BRACKET  
(8)



**H100202** | SCREW PWH BLK  
(144) | 8x5/8

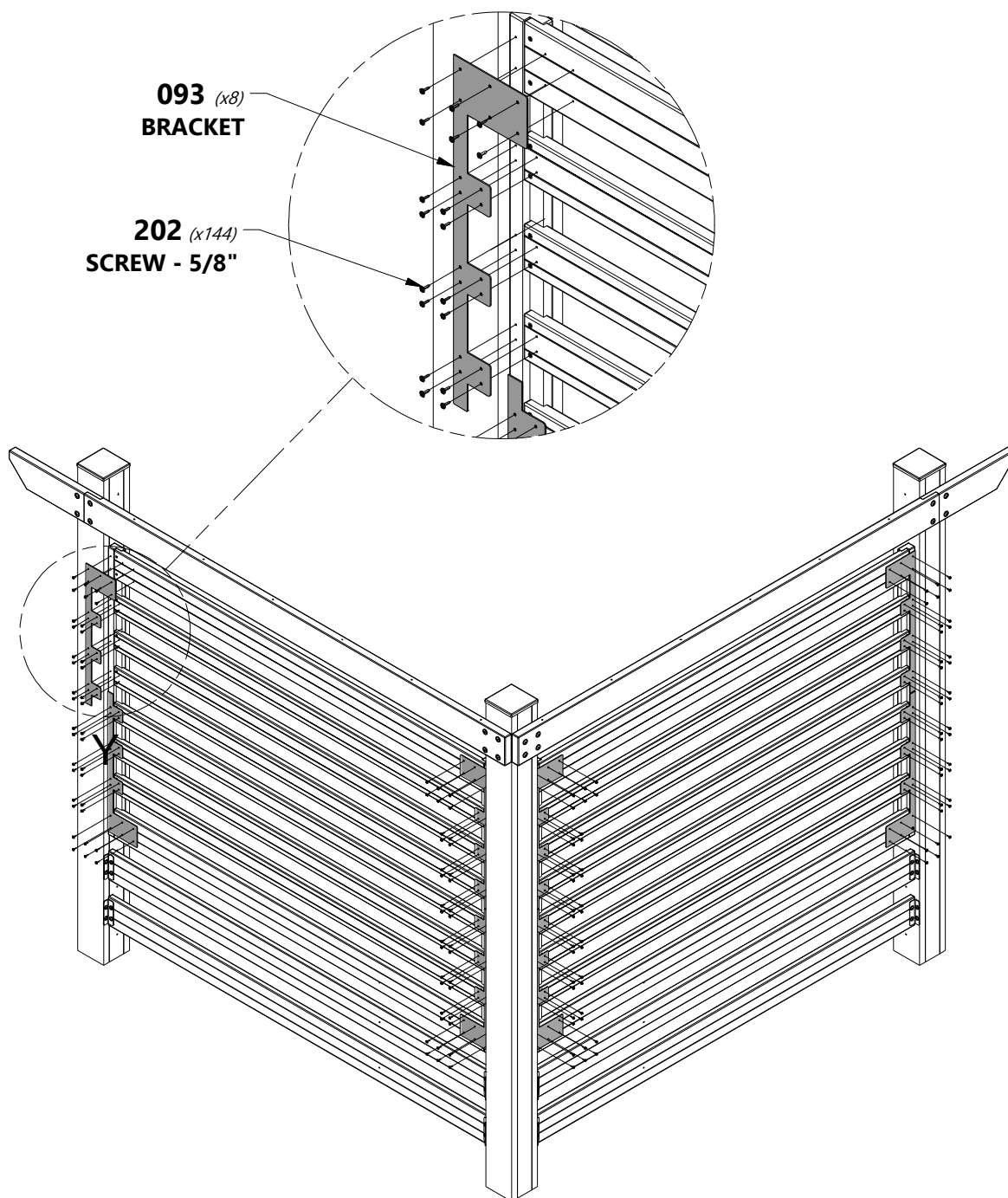



# STEP 6

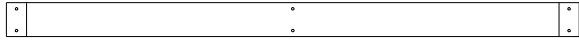

**G8** | BEAM - W4L13049  
(1) | 1"x5 1/4"x89 1/2" (24x134x2274)

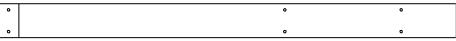

**G10** | BEAM - W4L13051  
(1) | 1"x5 1/4"x71 1/8" (24x134x1807)

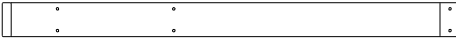

**G9** | BEAM - W4L13050  
(1) | 1"x5 1/4"x71 1/8" (24x134x1807)



**G7** | BEAM END - W4L13048  
(1) | 1"x5 1/4"x29" (24x134x736)

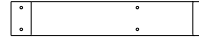

**G14** | BEAM END - W4L13062  
(1) | 1"x5 1/4"x29" (24x134x736)

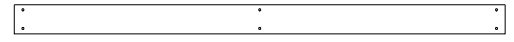

**A4M01111** | METAL BEAM  
(1)



**H100407** | BOLT WH BLK  
(6) | 5/16x1-1/2



**H100198** | WASHER LOCK EXT BLK  
(6) | 8x19



**H100199** | WASHER LOCK EXT BLK  
(6) | 12x19

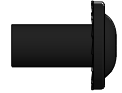

**H100192** | NUT BARREL WH BLK  
(6) | 5/16x7/8

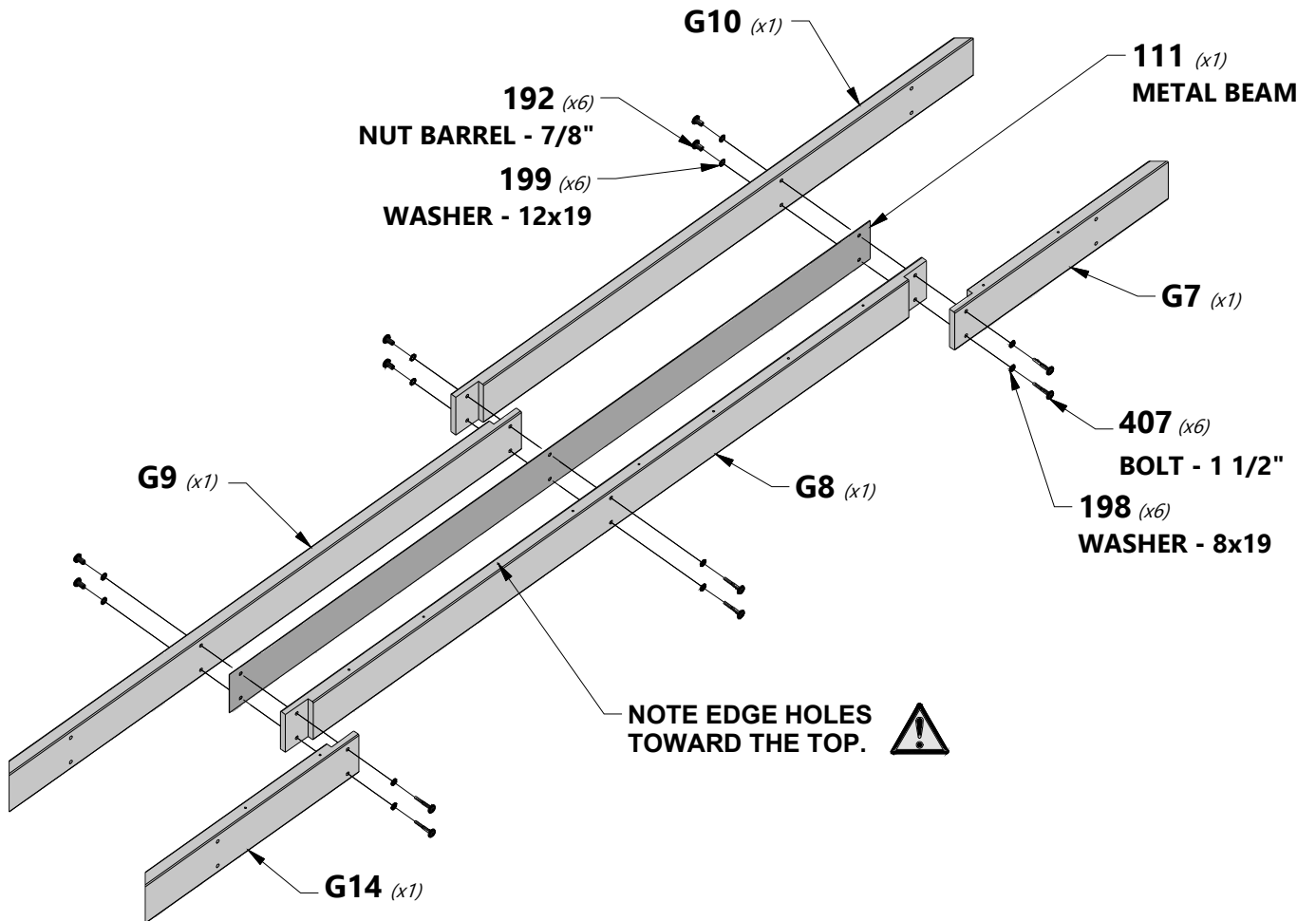





# STEP 7

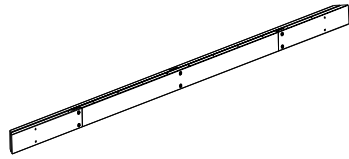

(1) **FRONT BEAM SUBASSEMBLY**  
(FROM STEP 6).



**H100206 | LAG SCREW WH**  
(4) | 5/16x3



**H100198 | WASHER LOCK EXT BLK**  
(4) | 8x19

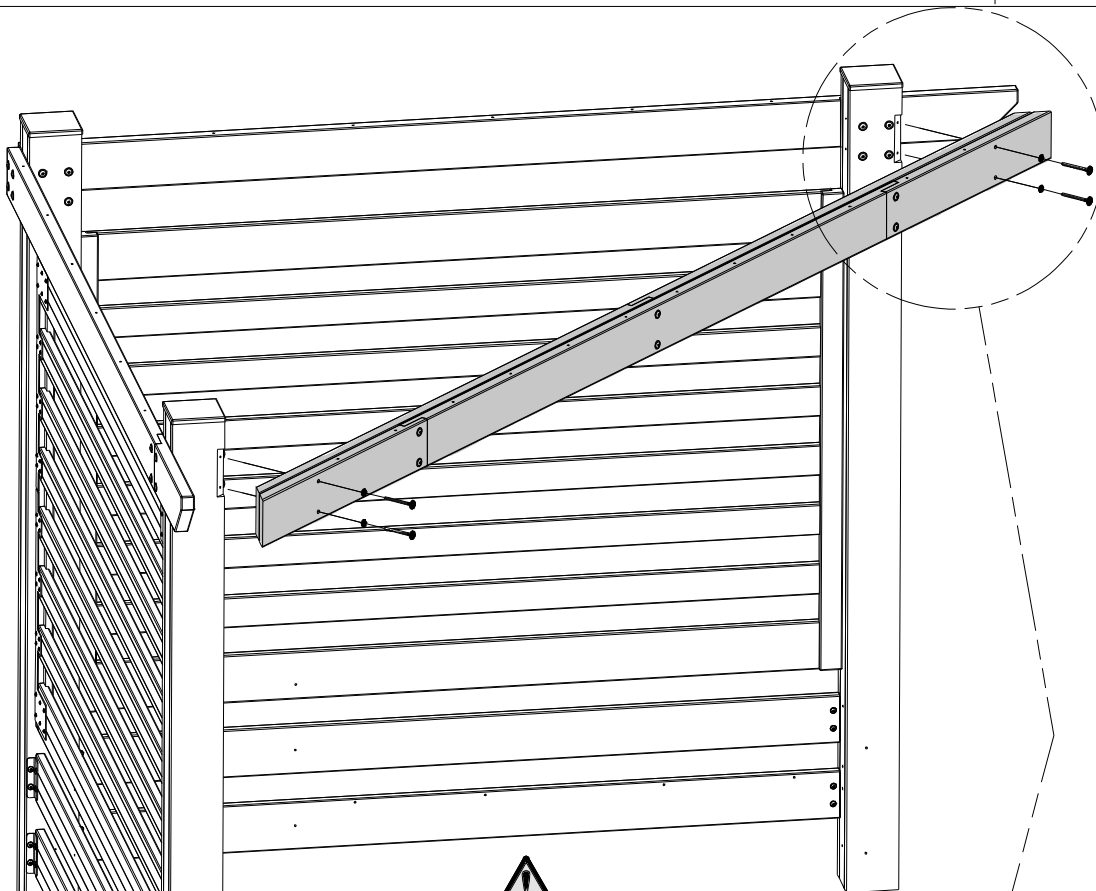

**ALIGN HOLES IN BEAM  
WITH HOLE LOCATED  
IN NOTCH.**



**EDGE HOLES TOWARD  
THE TOP OF THE BEAM.**

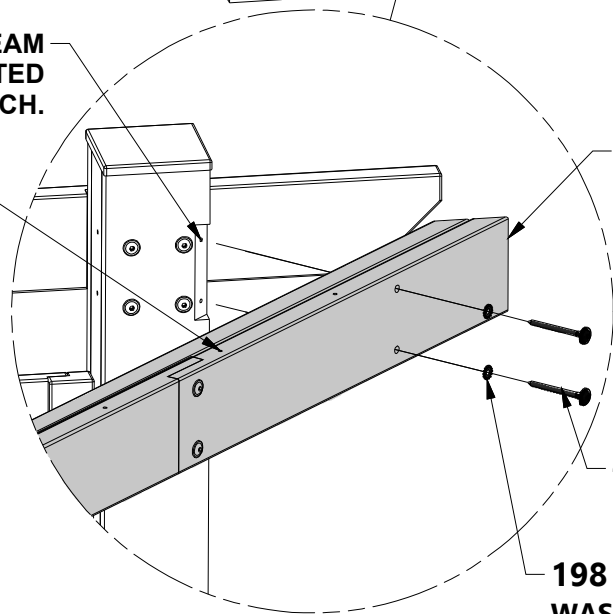

**BEAM SUBASSEMBLY  
(FROM STEP 6).**

**206 (x4)  
LAG - 3"**

**198 (x4)  
WASHER - 8x19**



# STEP 8

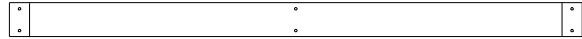

**G8** | BEAM - W4L13049  
(1) | 1"x5 1/4"x89 1/2" (24x134x2274)



**G12** | BEAM - W4L13053  
(1) | 1"x5 1/4"x61 1/4" (24x134x1555)

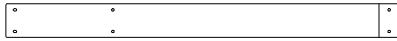

**G13** | BEAM - W4L13054  
(1) | 1"x5 1/4"x61 1/4" (24x134x1555)



**G11** | BEAM END - W4L13052  
(1) | 1"x5 1/4"x19" (24x134x484)

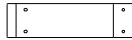

**G15** | BEAM END - W4L13063  
(1) | 1"x5 1/4"x19" (24x134x484)

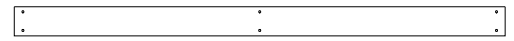

**A4M01111** | METAL BEAM  
(1)



**H100407** | BOLT WH BLK  
(6) | 5/16x1-1/2



**H100198** | WASHER LOCK EXT BLK  
(6) | 8x19



**H100199** | WASHER LOCK EXT BLK  
(6) | 12x19



**H100192** | NUT BARREL WH BLK  
(6) | 5/16x7/8

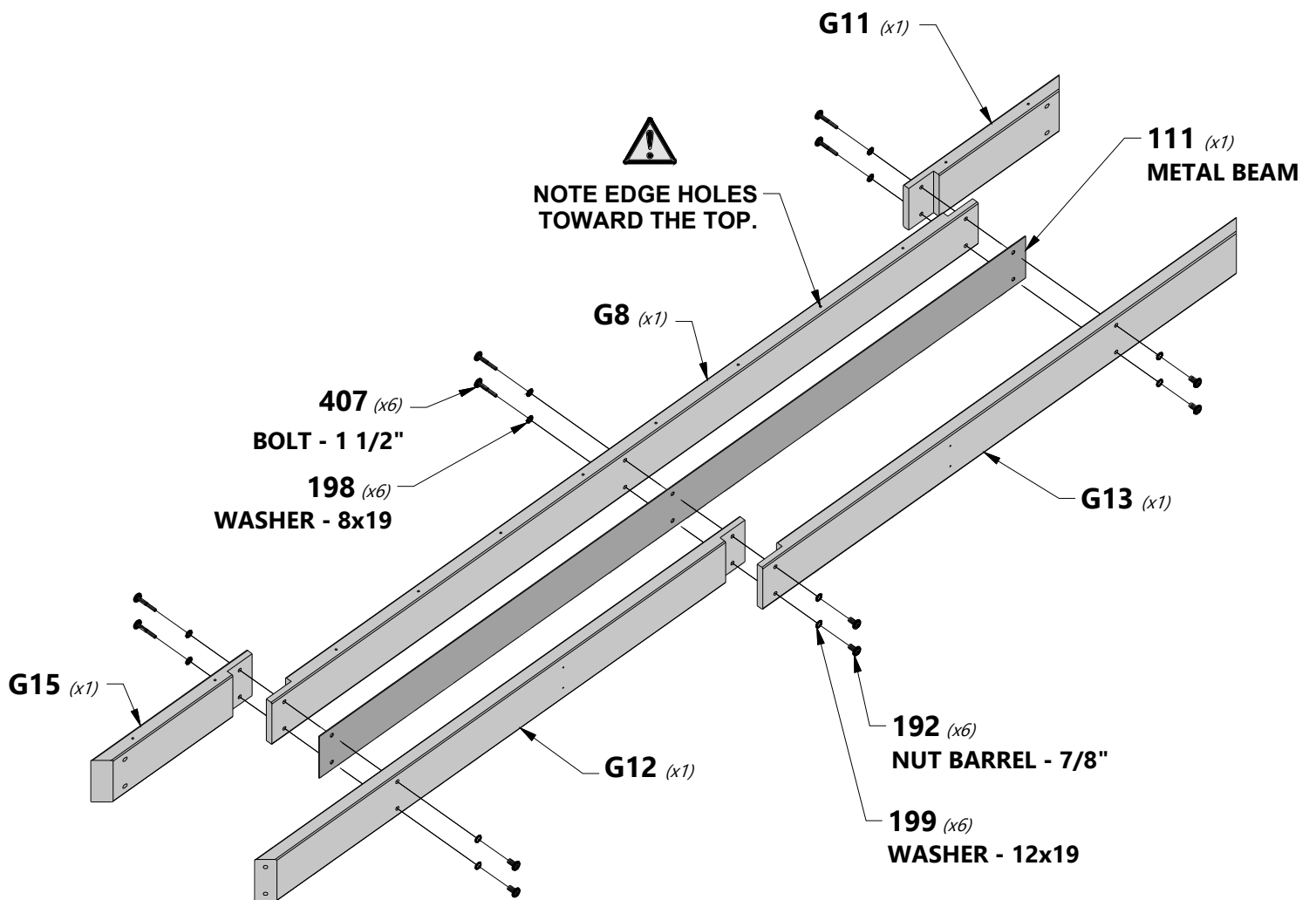



# STEP 9



**D5 | SUPPORT BRACE - W4L13055**  
(2) 1 3/8"x5 1/4"x4 5/8" (36x134x116)



**A4M00555 | 90° L-BRACKET - BLK**  
(8)



**H100202 | SCREW PWH BLK**  
(12) 8x5/8

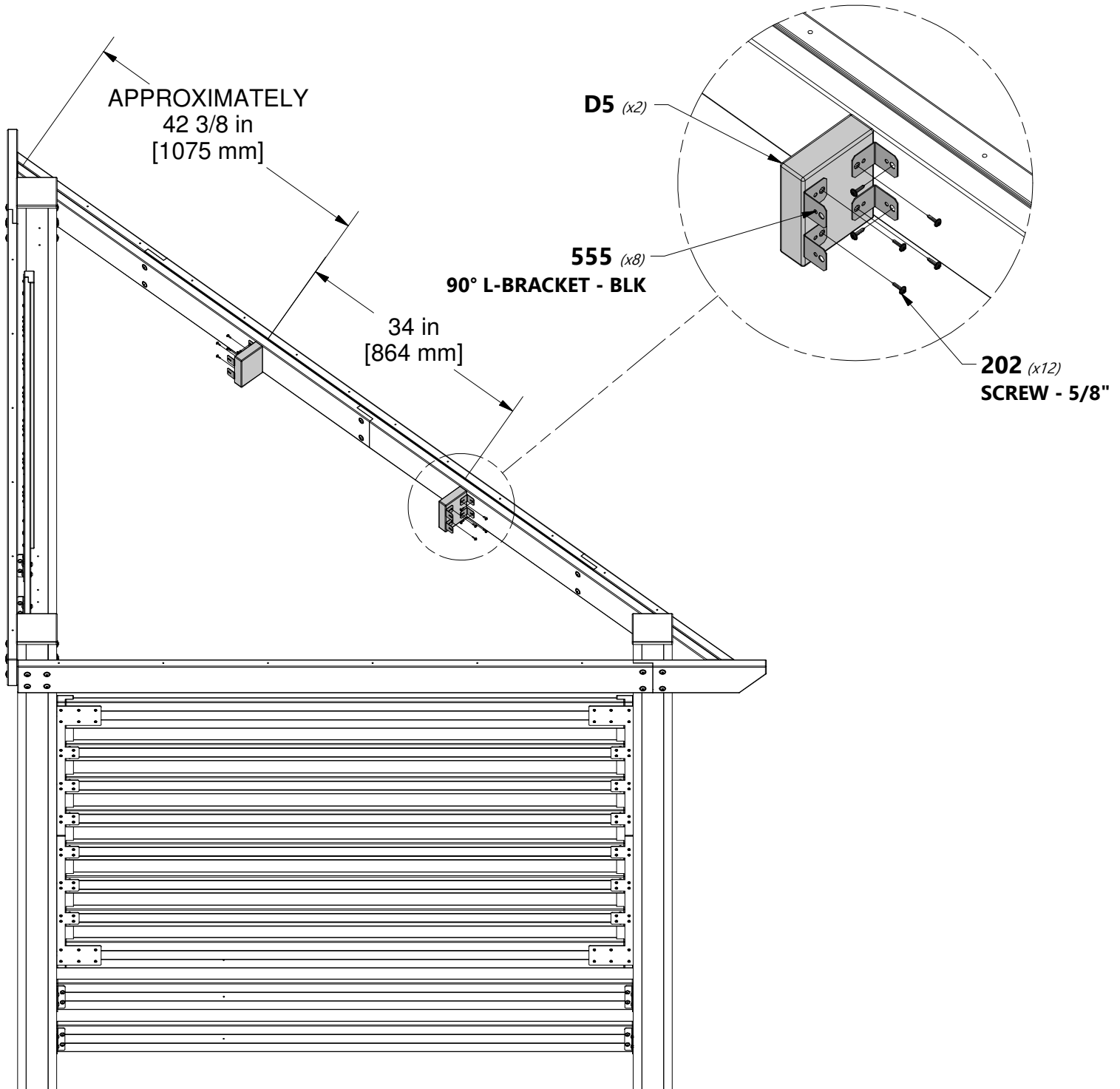



# STEP 10

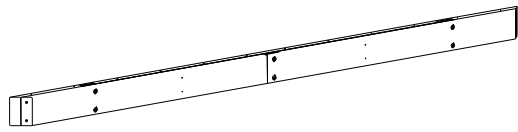

(1) **REAR BEAM SUBASSEMBLY**  
(FROM STEP 8).



**H100197 | LAG SCREW WH BLK**  
(4) | 5/16x2 1/2



**H100198 | WASHER LOCK EXT BLK**  
(4) | 8x19



**H100202 | SCREW PWH BLK**  
(4) | 8x5/8



**EDGE HOLES TOWARD  
THE TOP OF THE BEAM.**

**BEAM SUBASSEMBLY**  
(FROM STEP 8).

**198 (x4)**  
**WASHER - 8x19**

**197 (x4)**  
**LAG SCREW - 2 1/2"**

**202 (x4)**  
**SCREW - 5/8"**

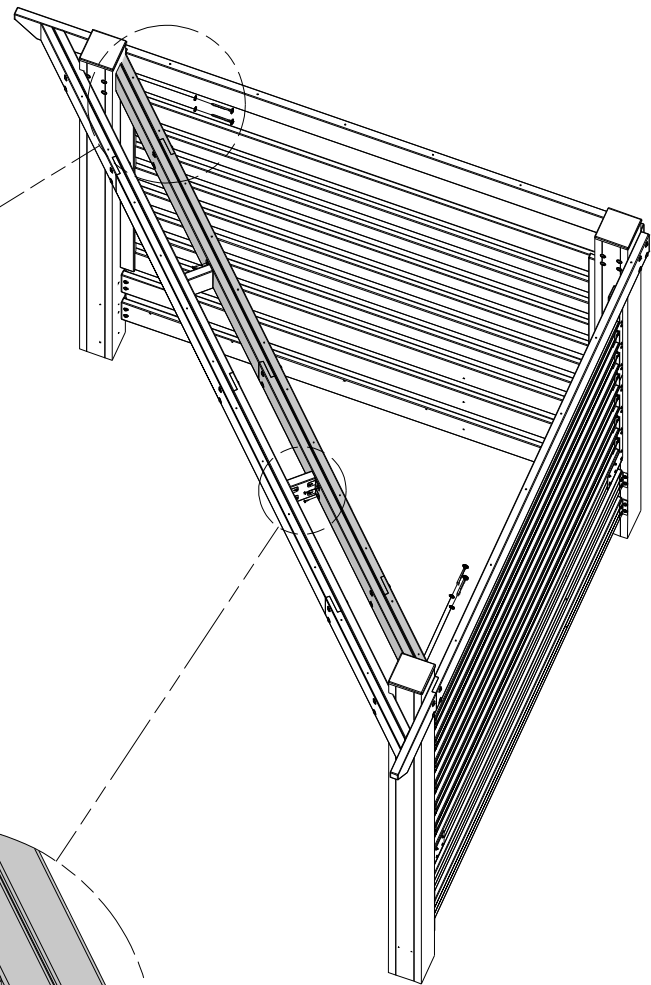



# STEP 11

7 in  
[179 mm]



**E1** | TOP JOIST - W4L13056  
(2) | 1 3/8"x3 3/8"x81 1/2" (36x86x2070)

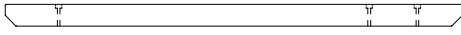

**E2** | TOP JOIST - W4L13057  
(2) | 1 3/8"x3 3/8"x71 1/2" (36x86x1817)



**E3** | TOP JOIST - W4L13058  
(2) | 1 3/8"x3 3/8"x61 1/8" (36x86x1553)

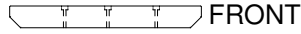

**E6** | TOP JOIST - W4L13061  
(2) | 1 3/8"x3 3/8"x30" (36x86x761)



**E5** | TOP JOIST - W4L13060  
(2) | 1 3/8"x3 3/8"x40 3/8" (36x86x1025)



**E4** | TOP JOIST - W4L13059  
(2) | 1 3/8"x3 3/8"x50 3/4" (36x86x1289)



**H100825** | LAG SCREW  
(36) | 5/16x4 BLK



**H100198** | WASHER LOCK EXT BLK  
(36) | 8x19

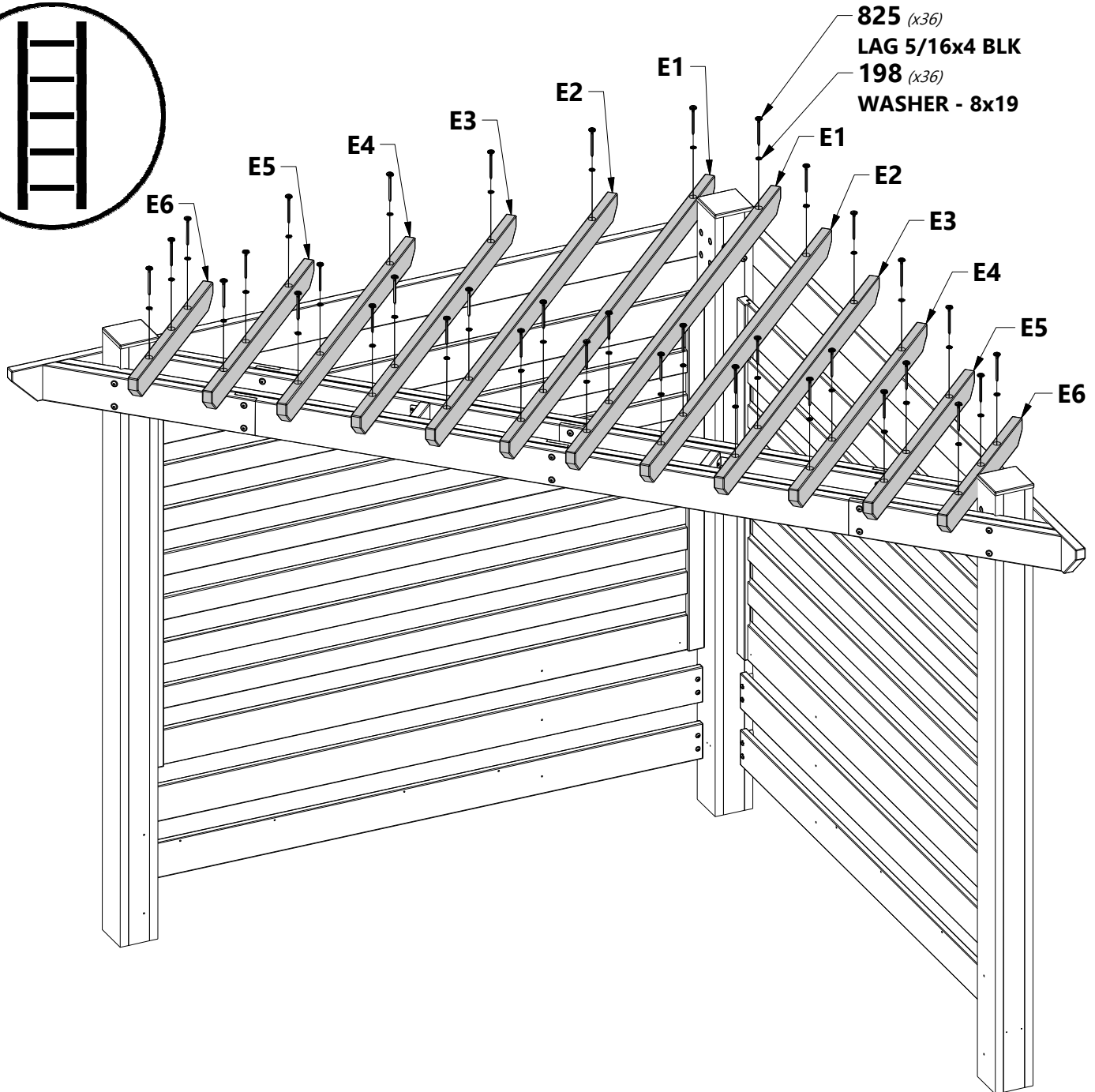
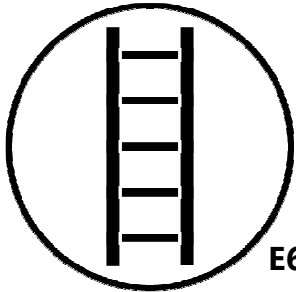



# STEP 12

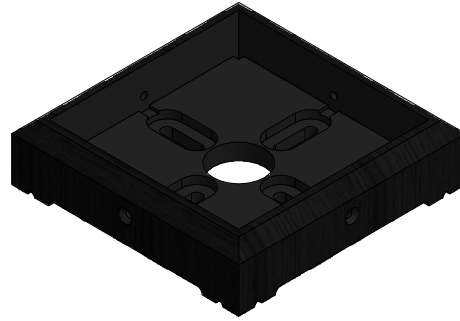

A100029  
(3) | FOOT 142 SQUARE POST



**NOTE:**

1. DECIDE WHERE TO PLACE THE PERGOLA. NOTE THIS MOUNTING PROCEDURE IS MEANT TO BE USED ON CONCRETE ONLY.
2. PLACE THE PERGOLA EXACTLY WHERE IT WILL BE ANCHORED WHEN COMPLETED AND SLIDE A FOOT UNDER EACH POST.

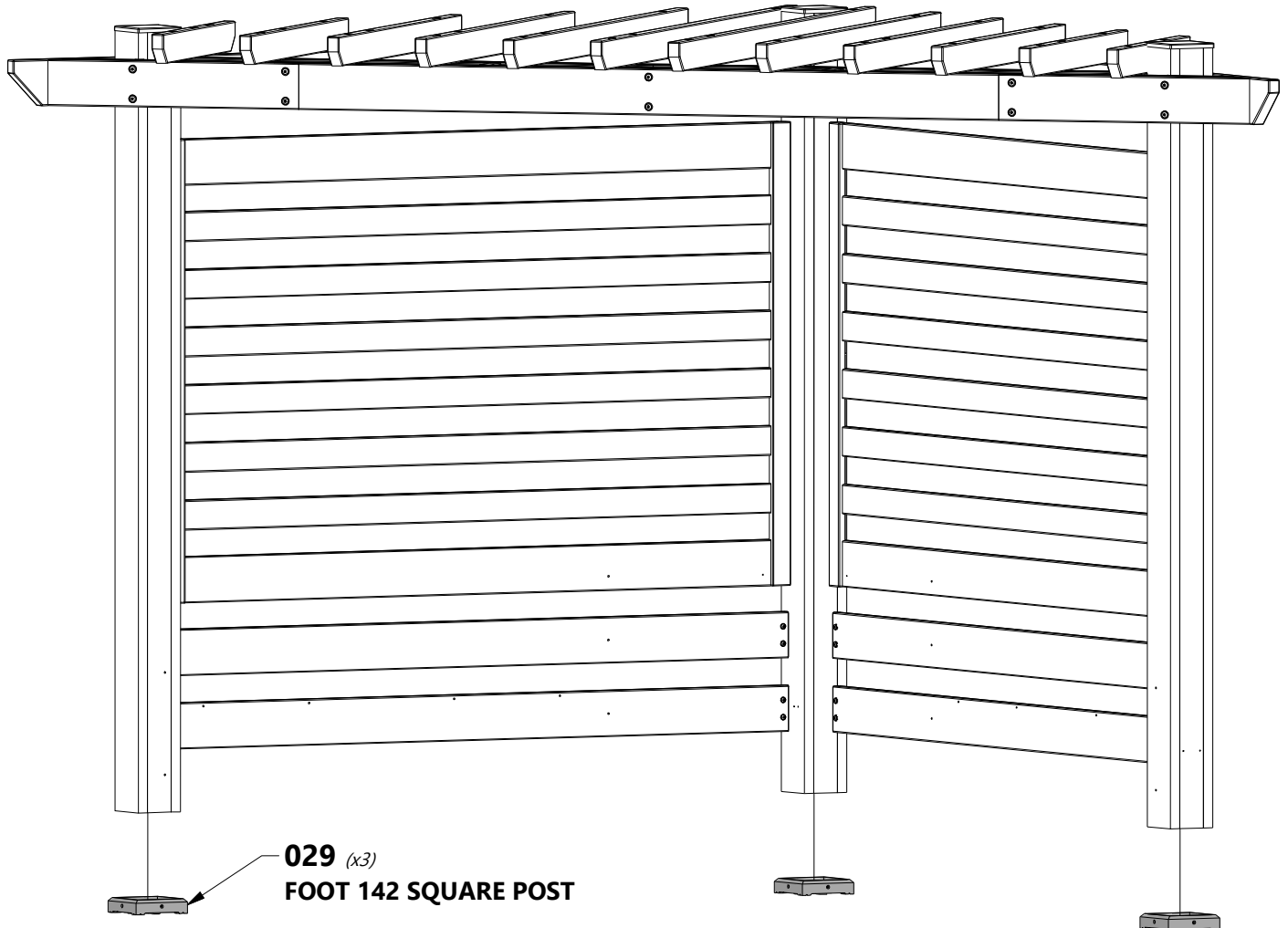



# STEP 13



H100120 | SCREW CONCRETE ANCHOR  
(12) | 1/4x2



**NOTE:**

*USE CHALK TO TRACE AROUND THE EDGES OF EACH FOOT.*

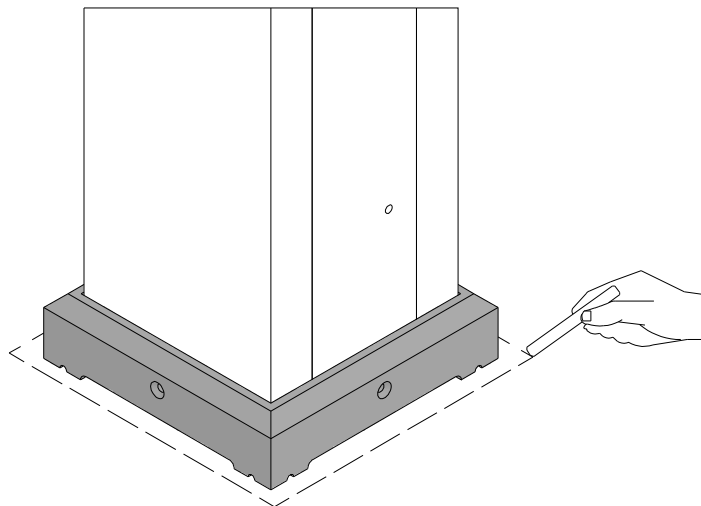

**NOTE:**

- 1. MOVE THE PERGOLA ASIDE. PLACE EACH FOOT INSIDE OF THE LINES DRAWN IN THE PREVIOUS STEP. USING A 3/16" CONCRETE DRILL BIT, PILOT DRILL ATTACHMENT HOLES INTO THE CONCRETE PAD.**
- 2. USE THE 1/4"x2" CONCRETE ANCHORS TO ATTACH EACH FOOT TO THE CONCRETE SURFACE.**

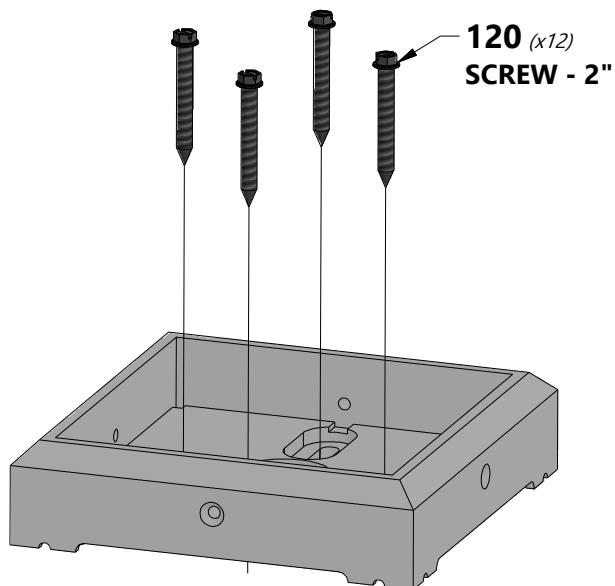



# STEP 14



A100314 (1) "A" REVISION TAG



H100200 | SCREW PFH BLK  
(12) | 8x1 1/2



H100392 | SCREW PWH BLK  
(4) | 8x3/4

A100241 (1) | BYD ID TAG (SMALL) WITHOUT AGES



### NOTE:

MOVE THE PERGOLA BACK IN TO PLACE, SETTING EACH POST INSIDE A FOOT AND MOUNT.

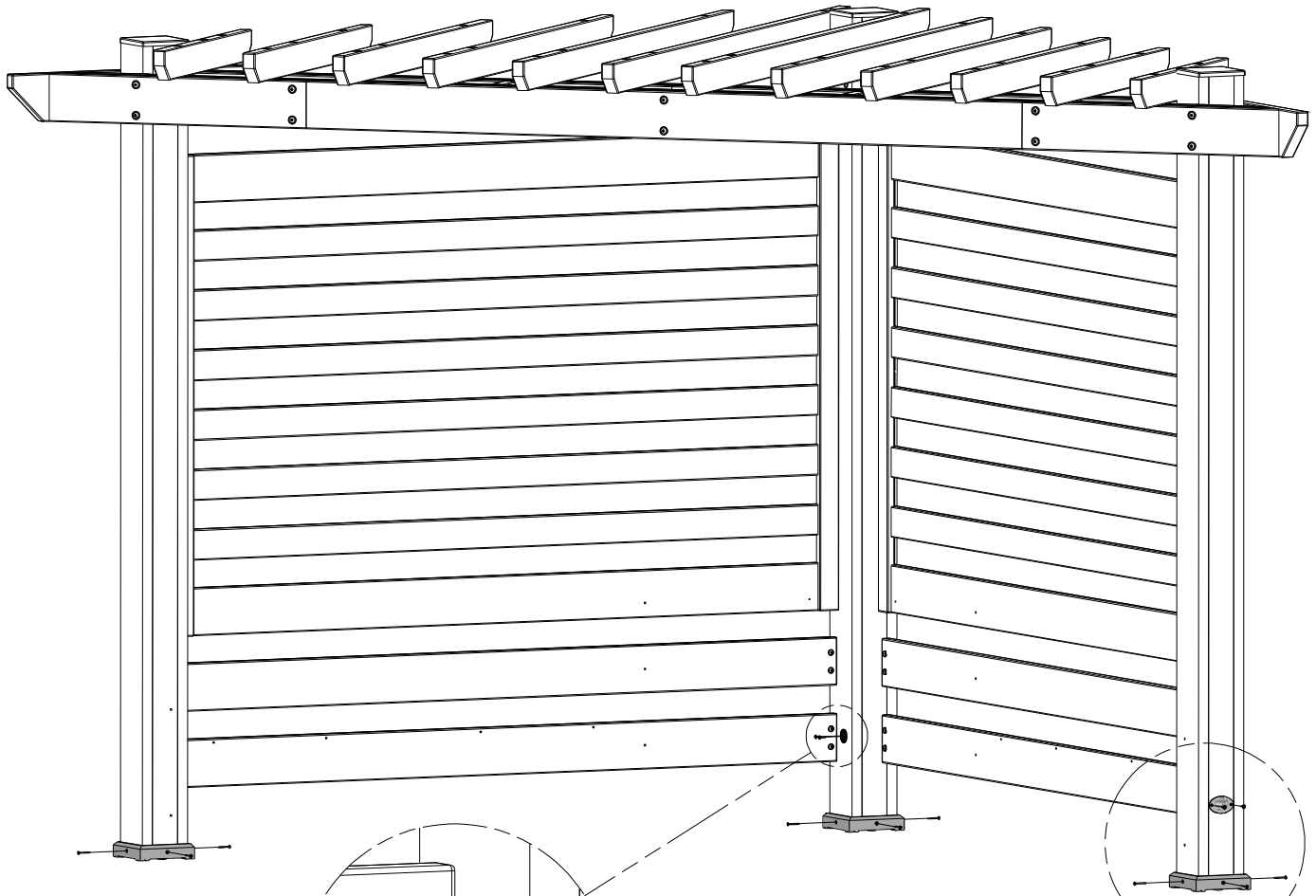

392 (x2)  
SCREW - 3/4"

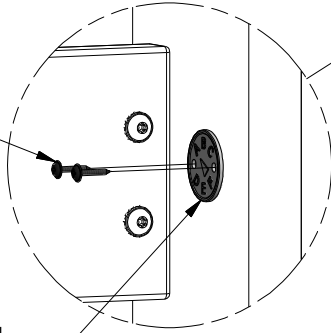

314 (x1)  
"A" REVISION TAG

241 (x1)  
BYD ID TAG

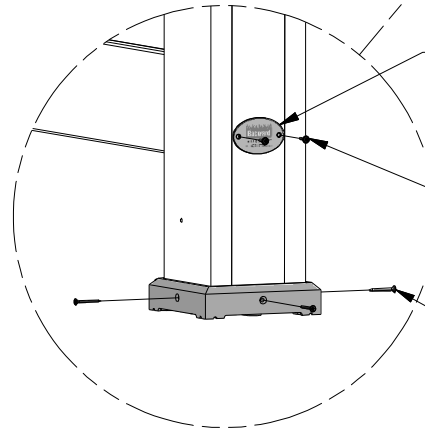

392 (x2)  
SCREW - 3/4"

200 (x12)  
SCREW - 1 1/2"





# STEP 15

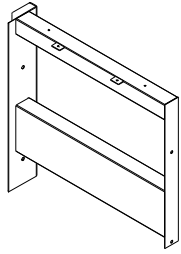

**A4M01060**  
(1) | **FRAME END - LEFT**

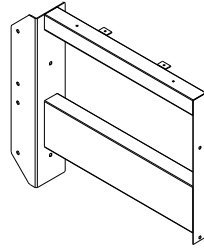

**A4M01066**  
(1) | **FRAME END - RIGHT**

**A6P00377**  
(2) | **SNAP-IN SQUARE PLUG**

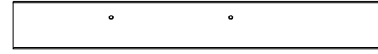

**A4M01105**  
(1) | **ARM POST - RIGHT**

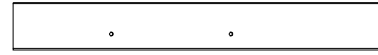

**A4M01106**  
(1) | **ARM POST - LEFT**



**H100171**  
(4) | **BOLT WH BLK**  
1/4x1

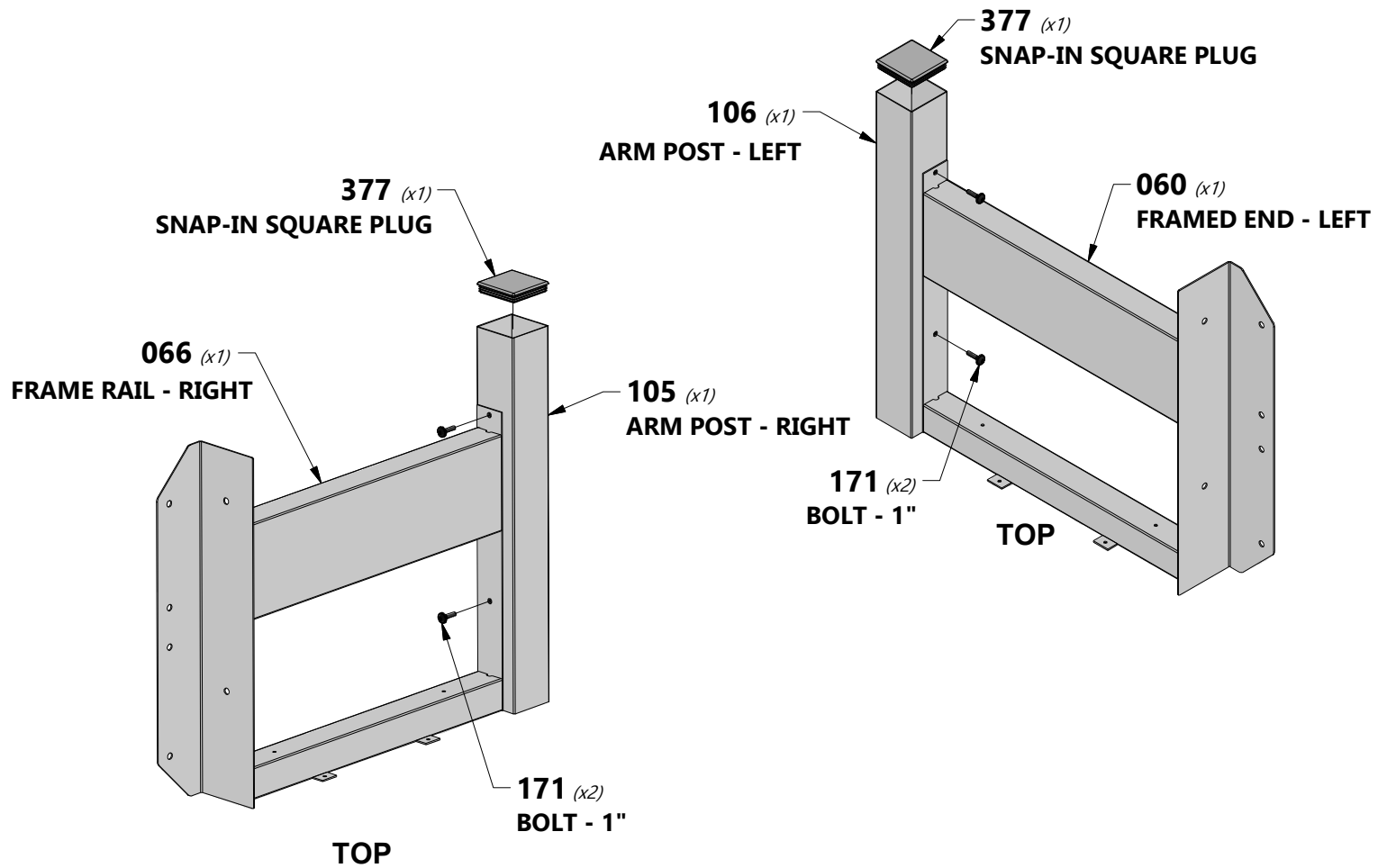



# STEP 16

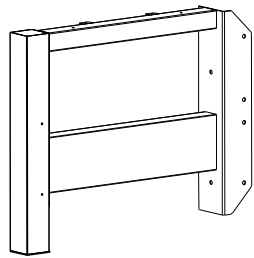

(1) METAL ARM - LEFT  
SUBASSEMBLY

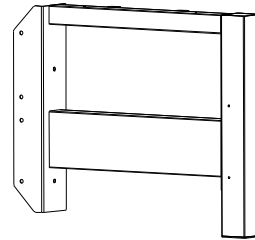

(1) METAL ARM - RIGHT  
SUBASSEMBLY



H100471 | LAG SCREW WH BLK  
(10) | 5/16x1 1/2

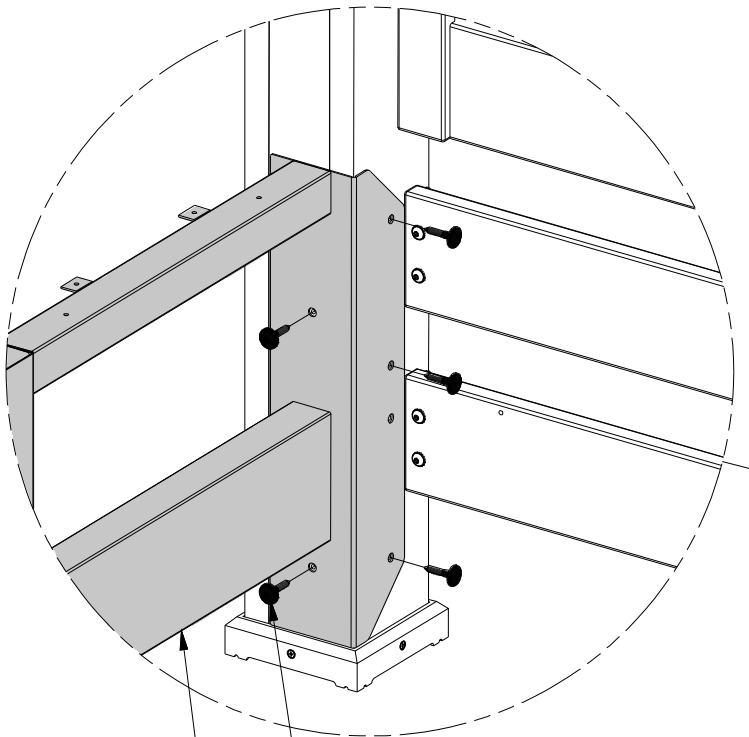

471 (x10)  
LAG SCREW - 1 1/2"  
(RIGHT & LEFT ARMS)

METAL ARM - LEFT  
SUBASSEMBLY (x1)

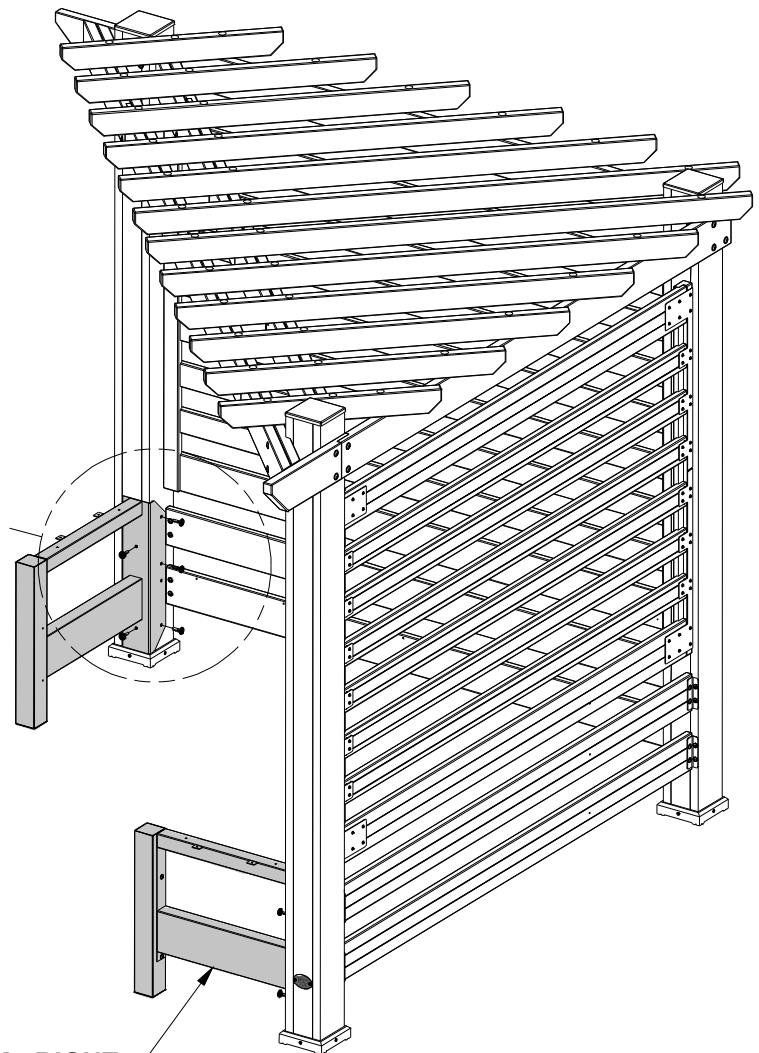

METAL ARM - RIGHT  
SUBASSEMBLY (x1)



# STEP 17

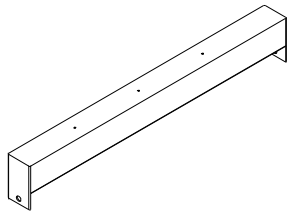

**A4M01065** | RAIL  
(2)

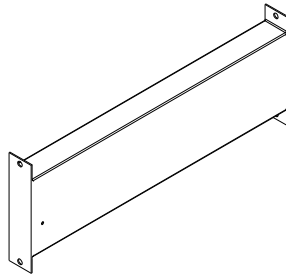

**A4M01095** | RAIL  
(2)

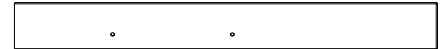

**A4M01063** | POST  
(1)



**A4M01069** | POST  
(1)



**A4M01070** | POST  
(1)



**H100171** | BOLT WH BLK  
(12) 1/4x1

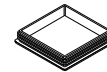

**A6P00377** | SNAP-IN SQUARE PLUG  
(3)

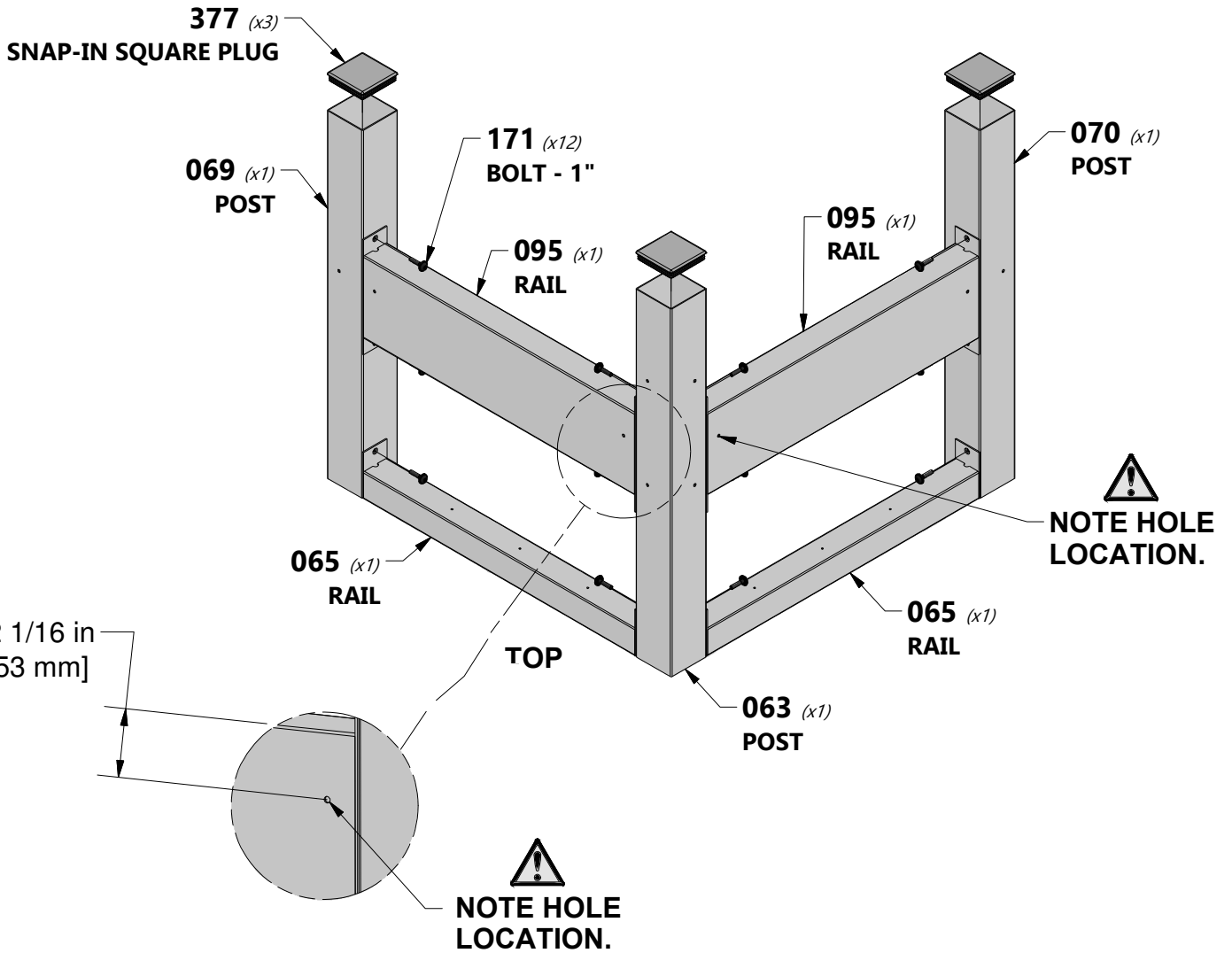



# STEP 18

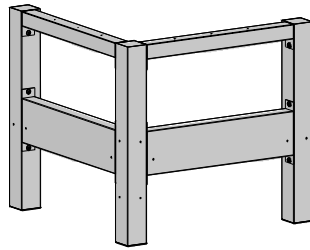

(1) METAL ARM TABLE BASE SUBASSEMBLY



H100391 | SCREW PFH BLK  
(6) | 8x2

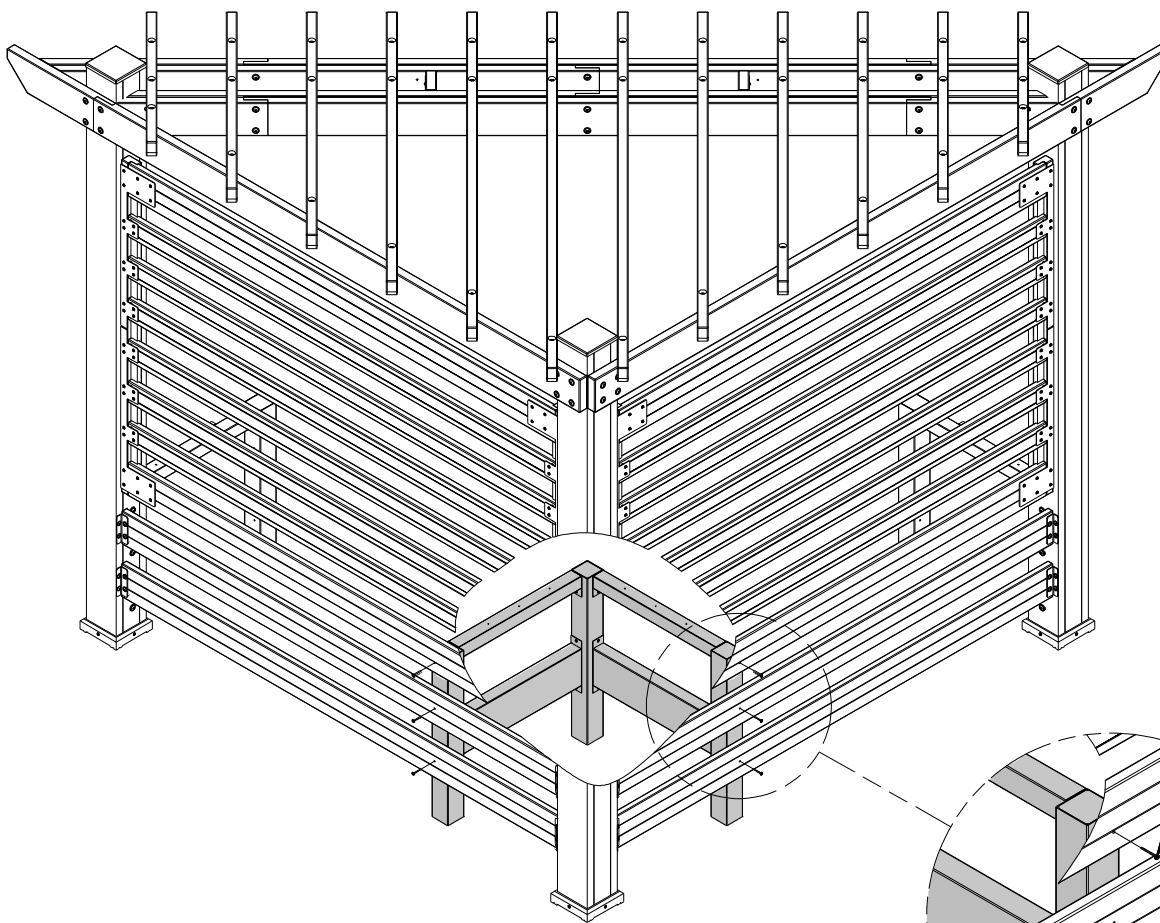

391 (x6)  
SCREW - 2"

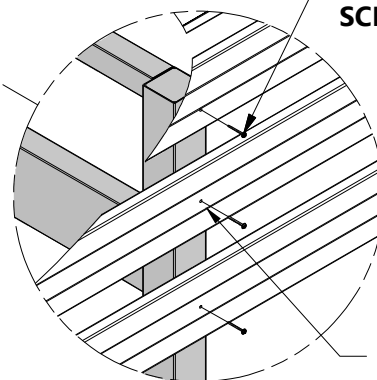

NOTE HOLE LOCATION.



# STEP 19

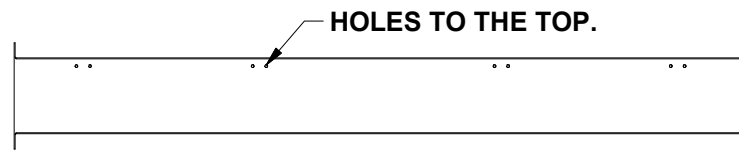

A4M01101 | RAIL  
(2)



H100171 | BOLT WH BLK  
(8) | 1/4x1

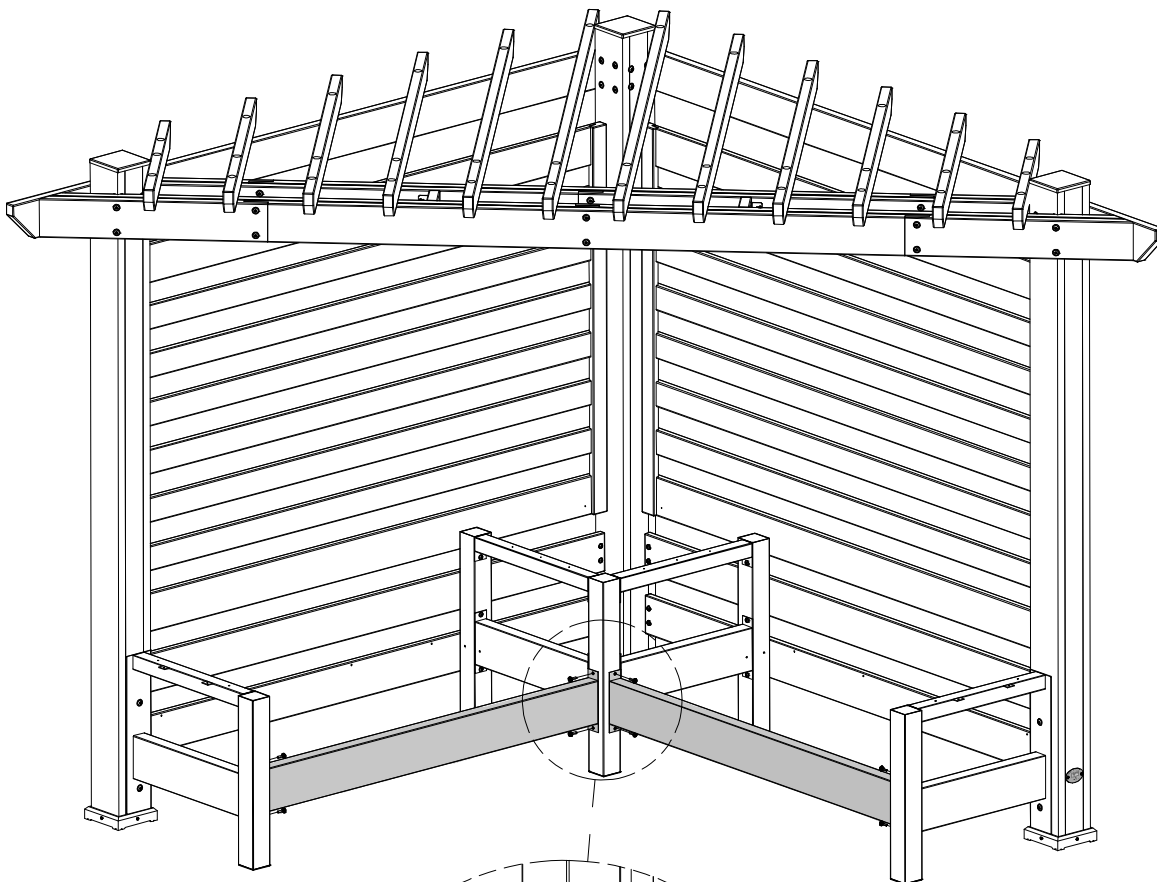

171 (x8)  
BOLT - 1"

101 (x2)  
RAIL





# STEP 20

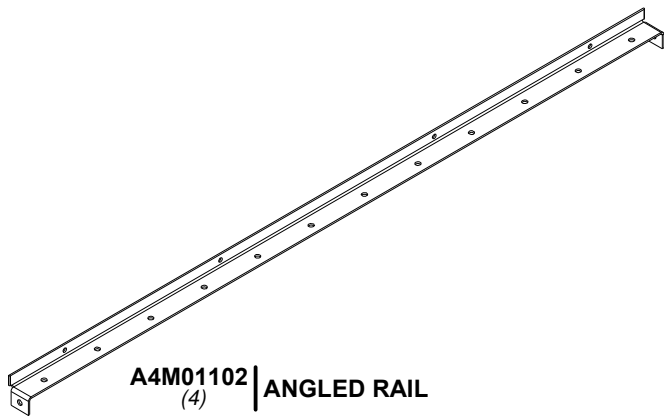

**A4M01102** | ANGLED RAIL  
(4)

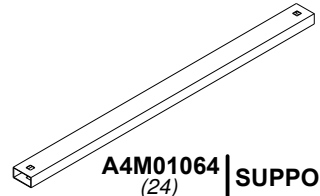

**A4M01064** | SUPPORT  
(24)



**H100712** | BOLT CARRIAGE BLK  
(48) | 5/16x1 1/2



**H100770** | WASHER FLAT  
(48) | 5/16 BLK



**H100479** | NUT LOCK BLK  
(48) | 5/16



**NOTE:**

LOOSELY TIGHTEN SEAT SUPPORT FRAME FOR EASIER ATTACHMENT TO METAL FRAME AND CABANA RAILS!

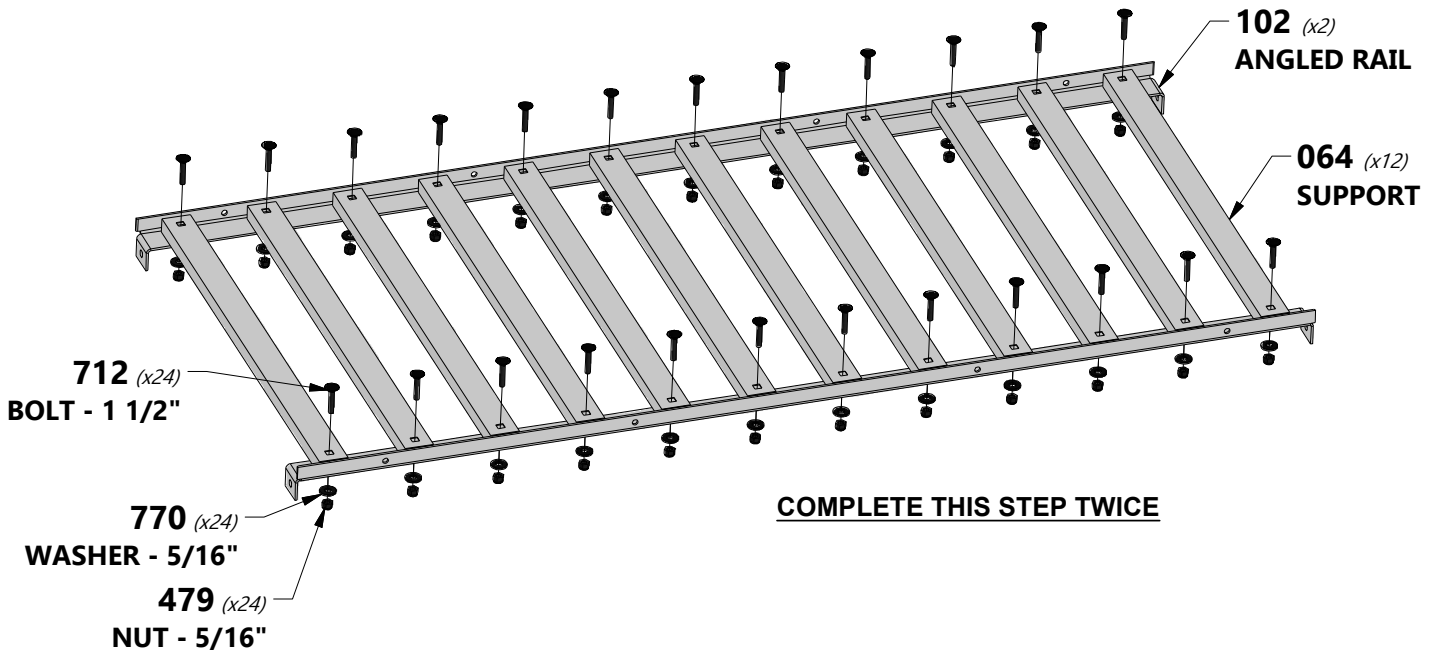



# STEP 21

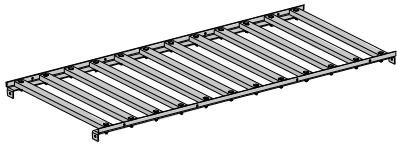

(2) SEAT SUPPORT SUBASSEMBLY



H100171 | BOLT WH BLK  
(12) | 1/4x1



H100460 | LAG SCREW WH BLK  
(10) | 1/4x1



### NOTE:

1. LINE UP THE PILOT HOLES IN THE WOOD RAILS WITH THE HOLES IN THE SEAT SUPPORT RAILS FOR PROPER ASSEMBLY.

2. AFTER SEAT SUPPORT SUBASSEMBLIES ARE INSTALLED, FINISH TIGHTENING ALL THE BOLTS AND SCREWS FROM PREVIOUS STEP.

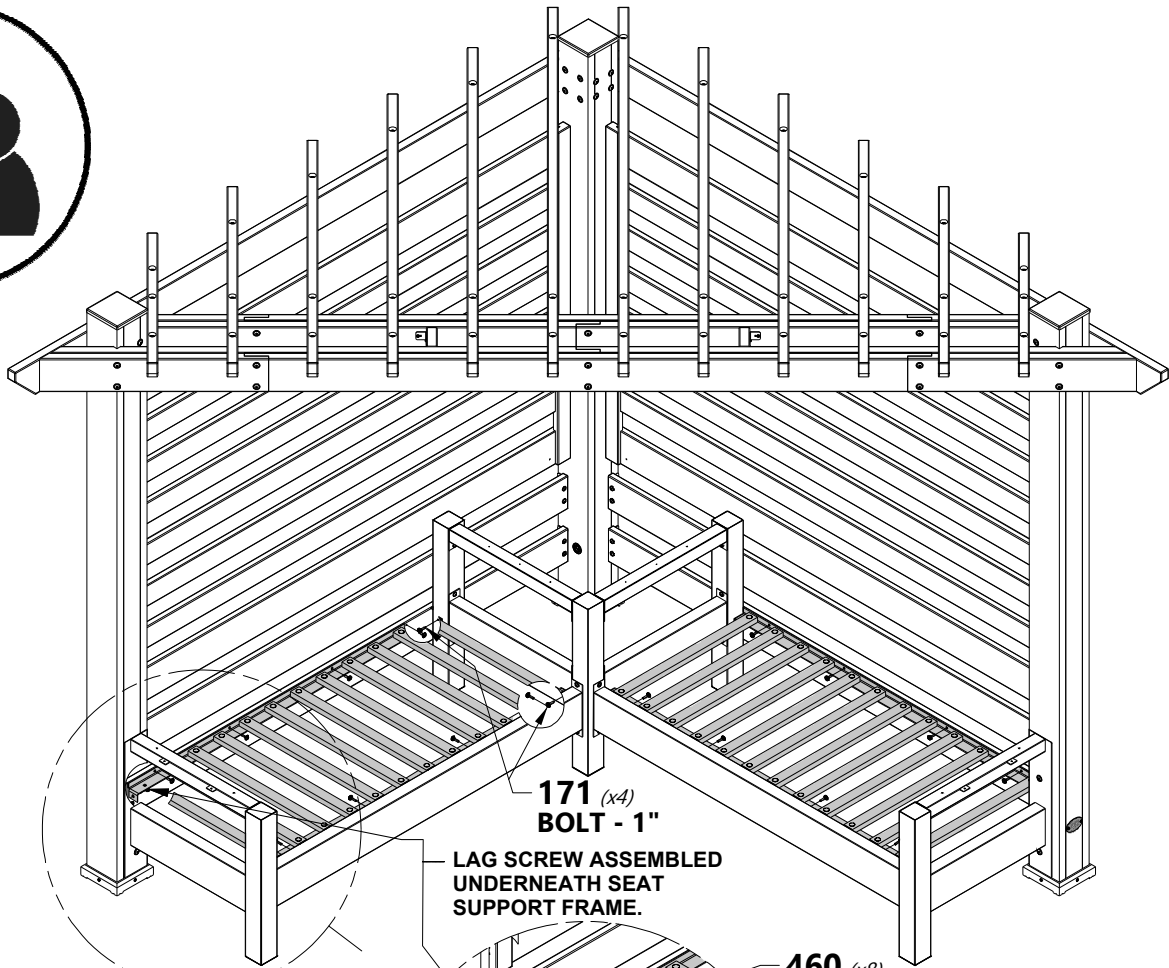
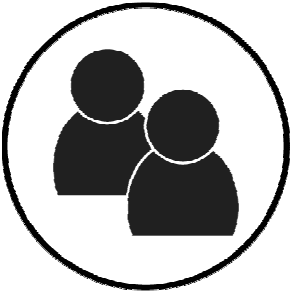

171 (x4)  
BOLT - 1"

LAG SCREW ASSEMBLED UNDERNEATH SEAT SUPPORT FRAME.

460 (x8)  
LAG SCREW - 1"  
(BACK L-BRACKET)

171 (x8)  
BOLT - 1"  
(FRONT L BRACKET & (2) CORNERS)

460 (x2)  
LAG SCREW - 1"  
(POST CONNECTION)

**REPEAT PROCESS FOR BOTH SEAT SUPPORT SUBASSEMBLIES.**



# STEP 22

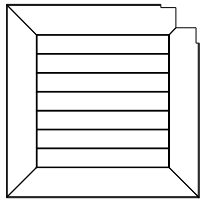

**TT1** | TABLE TOP - W2A02925  
(1) | 1 5/16"x30 1/8"x30 1/8" (34x765x765)

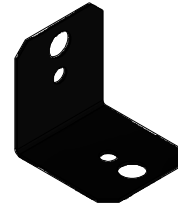

**A4M00555** | 90° L-BRACKET - BLK  
(2)



**H100202** | SCREW PWH BLK  
(4) | 8x5/8



**H100824** | SCREW PWH BLK  
(6) | 8x3



**NOTE:**  
ASSEMBLE REAR CORNER L-BRACKETS FIRST.

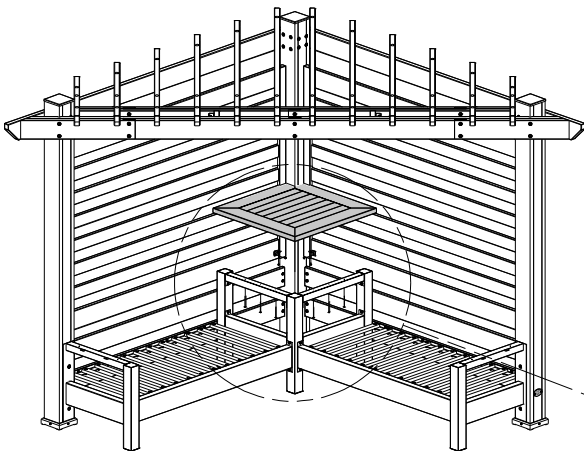

**TT1 (x1)**  
TABLE TOP

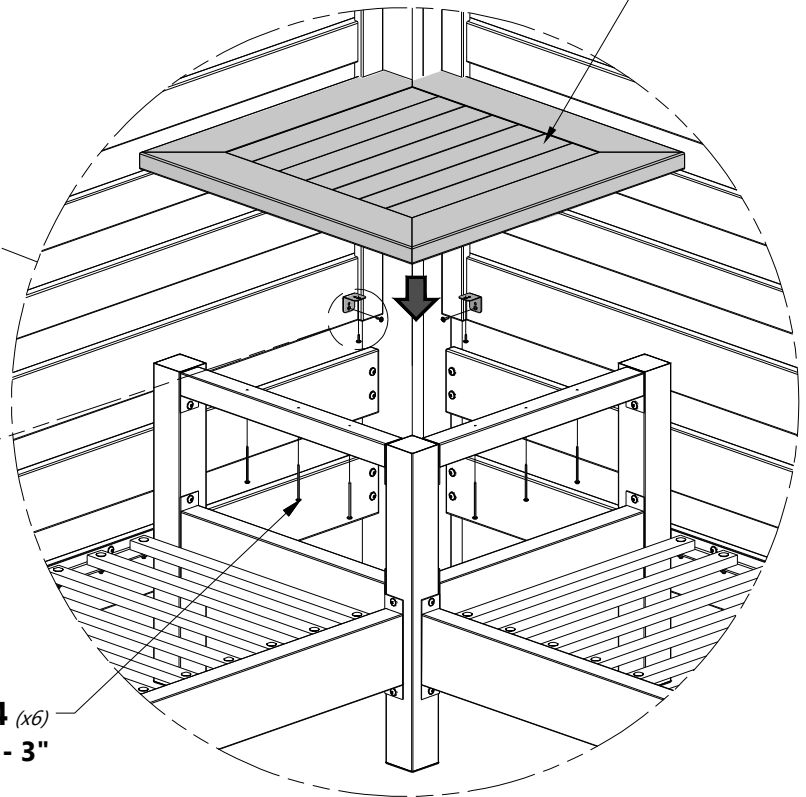

**555 (x2)**  
90° L-BRACKET - BLK

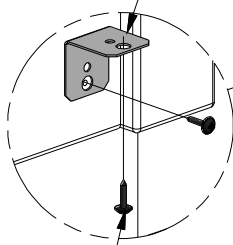

**202 (x4)**  
SCREW - 5/8"

**824 (x6)**  
SCREW - 3"





# STEP 23



**D7** | **ARM REST - W4L13068**  
(2) | 1 3/8"x5"x26" (36x126x660)

  
**H100824** | **SCREW PWH BLK**  
(4) | 8x3

  
**H100392** | **SCREW PWH BLK**  
(4) | 8x3/4

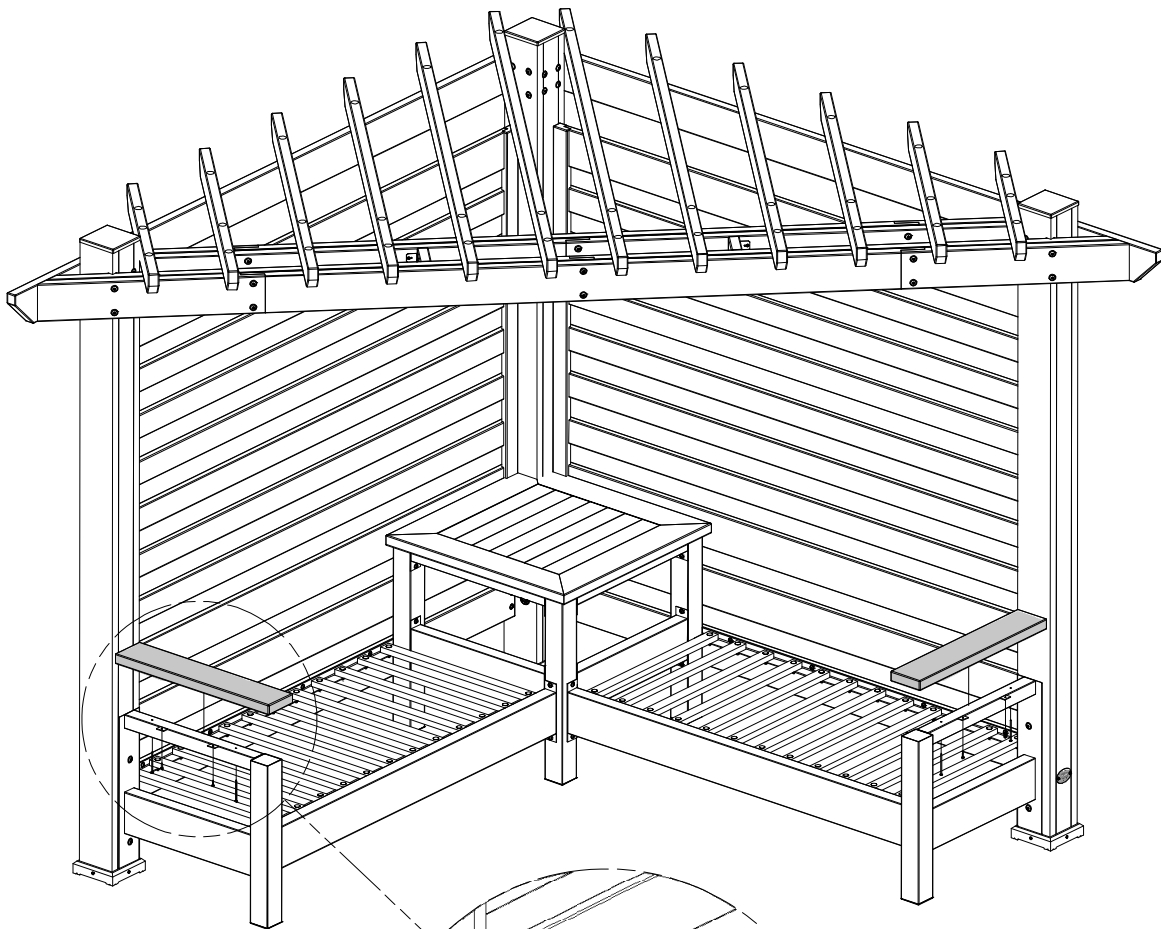

**REPEAT PROCESS FOR BOTH  
ARM RESTS.**

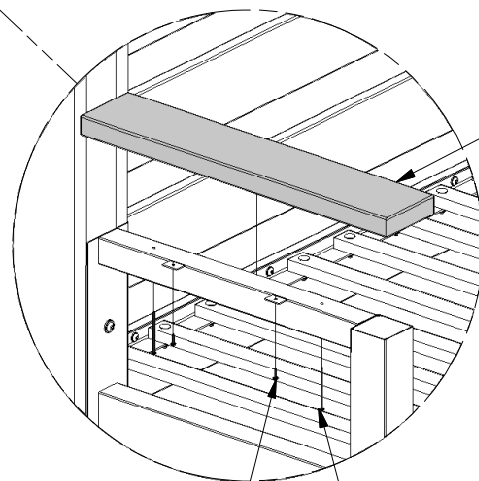

**D7** (x2)  
**ARM REST**

**392** (x4)  
**SCREW - 3/4"**

**824** (x4)  
**SCREW - 3"**



# STEP 24

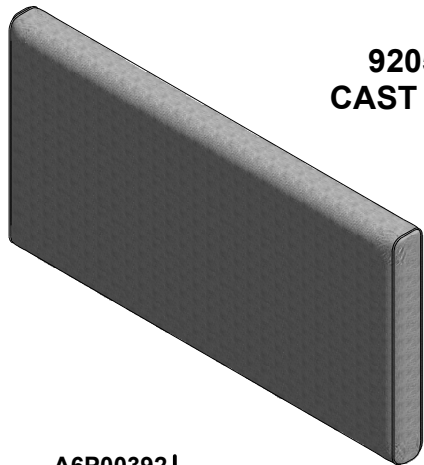

**9205109**  
**CAST SLATE**

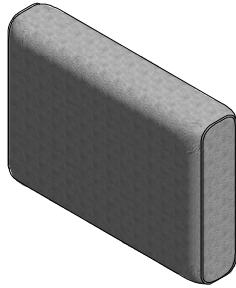

**A6P00392** | SEAT CUSHION  
*(2)*

**A6P00393** | BACK CUSHION  
*(4)*

OR

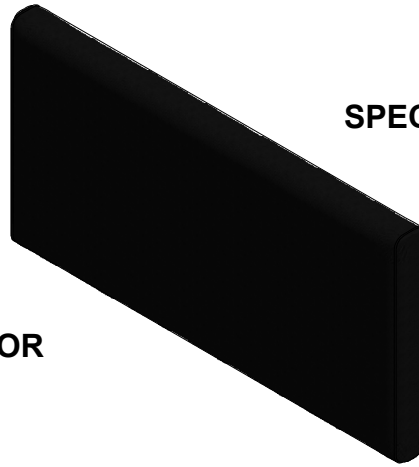

**9205116**  
**SPECTRUM INDIGO**



**A6P00394** | SEAT CUSHION  
*(2)*

**A6P00395** | BACK CUSHION  
*(4)*

