

PRODUCT SPECIFICATIONS

Model: TC70125

Power supply voltage:	120 V-60 Hz	Working width:	16-IN
Tine Speed:	370 RPM	Working depth max:	8-IN
Power Consumption:	12.5 Amp		

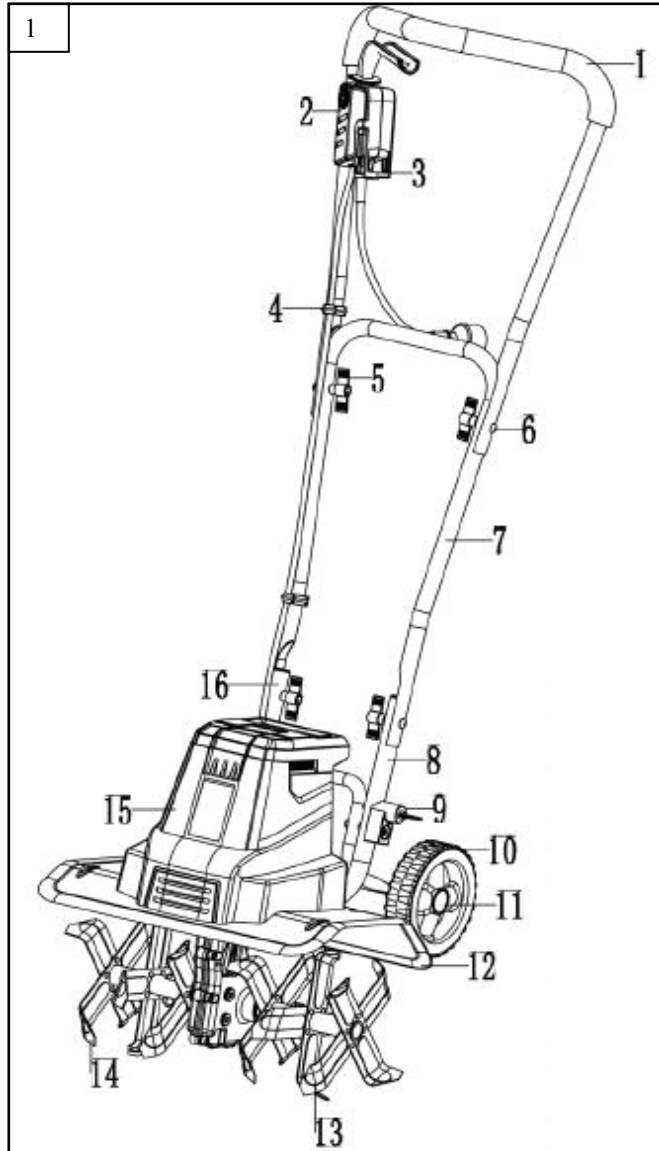

No.	Description	No.	Description
1	Upper handle section	9	Wheel frame lock pin
2	Switch box and power cable assembly	10	Wheel
3	Cord retainer	11	Wheel hub cap
4	Cable clip	12	Protective shield
5	Wing nut	13	Tine assembly, A
6	Carriage bolt M6 x 45	14	Tine assembly, B
7	Center handle section	15	Motor housing
8	Lower handle section - I	16	Lower handle section - II