



NORAH BACKLESS NOOK UNFINISHED
NORAH COIN SANS DOSSIER INACHEVÉ
NORAH BANCO ESQUINERO SIN ESPALDA SIN ACABADO

ITEM# 903011UNF01U

Scan QR Code



for Assembly Video

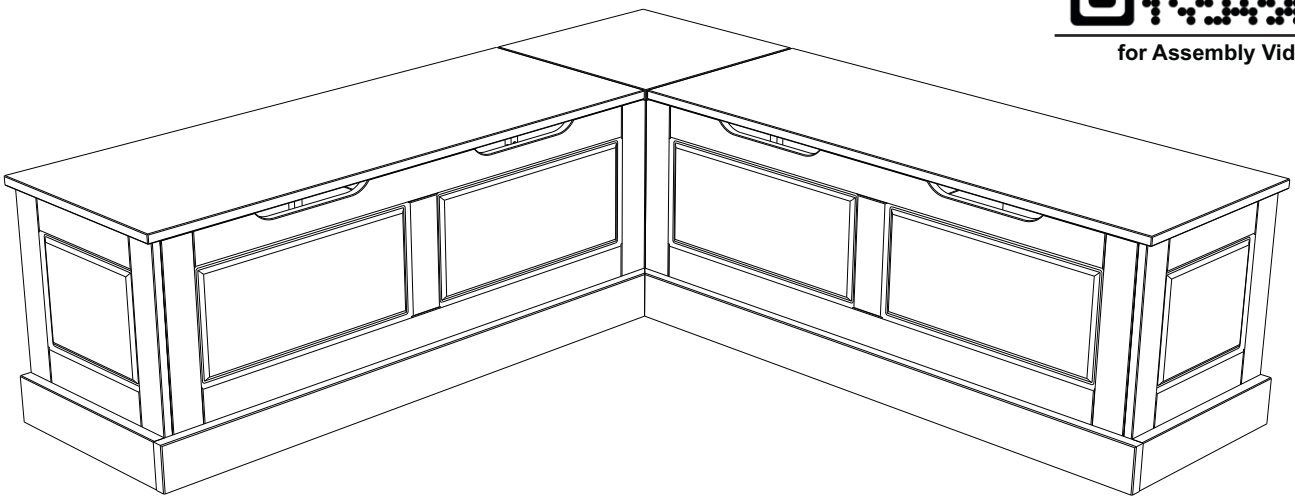

BR4 - 20236

LINON HOME DECOR PRODUCTS, INC.

WE ARE HERE TO HELP!

BEFORE YOU RETURN IT - CONTACT US.

We do our best to insure that your furniture arrives in excellent condition. In the event that a part is damaged or missing, Linon will be happy to provide you with replacement parts, at no charge, within 30 days of purchase, providing the parts are available in our warehouse and the item purchased is part of our current inventory. In order to receive spare parts, at no charge, you must provide proof of purchase within 30 days.

For further information, please contact our customer service department, c/o Linon Home Décor Products, Inc., between 9:00 AM and 5:00 PM EST, Monday through Friday.

Email address: consumersupport@linon.com

NOUS SOMMES LÀ POUR VOUS AIDER!

AVANT DE RETOURNER LE PRODUIT, VEUILLEZ COMMUNIQUER AVEC NOUS.

Nous faisons tout en notre pouvoir pour que vous receviez votre meuble en parfait état. Toutefois, si une pièce est endommagée ou manquante, Linon se fera un plaisir de vous envoyer gratuitement la pièce de rechange, dans les 30 jours suivant l'achat, à condition que nous ayons la pièce en stock et que le produit acheté fasse partie de notre inventaire courant. Afin de recevoir gratuitement la pièce de rechange, vous devez fournir une preuve d'achat dans un délai de 30 jours.

Pour de plus amples renseignements, veuillez communiquer avec notre département du service à la clientèle, entre 9 h et 17 h HNE, du lundi au vendredi.

Adresse de courriel : consumersupport@linon.com

¡ESTAMOS AQUÍ PARA AYUDARLE!

ANTES DE REGRESAR EL PRODUCTO, COMUNÍQUESE CON NOSOTROS.

Hacemos todo lo posible para que su mobiliario se le entregue en excelentes condiciones. En caso de que falte una pieza o esté dañada, Linon le enviará con gusto la pieza de repuesto sin ningún costo dentro de los 30 días posteriores a la compra, siempre y cuando tengamos en existencia las piezas en nuestros almacenes y que el artículo comprado forme parte de nuestro inventario actual. Para recibir piezas de repuesto, sin costo adicional, debe enviarnos el comprobante de compra dentro de los 30 días después de la compra.

Si desea más información, póngase en contacto con nuestro departamento de servicio al cliente, de lunes a viernes entre las 9:00 a.m. y las 5:00 p.m., hora estándar de los Estados Unidos.

Correo electrónico: consumersupport@linon.com

LINON HOME DECOR PRODUCTS, INC.

Thank you for purchasing this unfinished piece of furniture!

These instructions will get you the best possible customized result when finishing this piece of furniture.

Getting Started

SAMPLE BOARD Please find an unfinished sample board included with your furniture. It's enclosed to help you get the best results as you finish the furniture. This small board allows you to test finishes including paint and stains before you start working on the furniture itself.

IMPORTANT Before diving into painting, assembly or other improvements, please carefully read the critical instructions below. Keep in mind that, for best results, furniture should be finished before you assemble it! In that way, the piece will get the most consistent and beautiful finish treatment.

STEP ONE To kick off your finishing project, the best procedure is to take the sample board, solid pine like the furniture, to a paint, hardware or home center store and consult with the paint specialist for recommendations about what paints, stains, wax and varnish work most effectively with solid pine. It's also a good idea to ask the specialist about the best methods of applying the finish recommended.

IMPORTANT Keep in mind that after applying the original finish, whether paint or stain, you should add a varnish or wax as a final application that will give you the best results.

RESEARCH ONLINE Online sources provide finishing advice and tutorials, so you can search generally or on YouTube for instructional videos made by experts covering topics including choosing and applying paints and stains to unfinished wood furniture as well as picking and using varnishes and waxes. Search specifically for instruction for pinewood or softwoods for best results. Please note, whatever brand of finish you select, the corporate website may have additional recommendations and even videos about how best to use the company's products. **Information available online may supplement but should not supersede these instructions, which are specific to your furniture.**

SET UP When ready to finish your furniture, layout all pieces on a covered floor space or tabletop. Ensure all wood surfaces are clean and free of dust. Keep in mind, the cardboard box in which the furniture arrived can be disassembled and used as a floor/table covering. Thorough preparation before painting/staining is crucial to getting the results you want!

Painting and Staining Preparation

SANDING Start by thoroughly sanding your furniture. Begin with a medium grit sanding sponge, recommended for its ability to better address corners, or with sandpaper. Sand all surfaces. Then step down to a fine-grit sanding sponge or sandpaper and repeat. End the sanding process with an extra fine grit sanding sponge, working all surfaces completely. Always sand in the direction of the grain.

CLEAN When the entire piece is completely sanded down, vacuum it to remove dust, debris and other loose material. After completely vacuuming the wood surfaces, use a soft cloth to remove fine dust particles from the wood. This step is crucial to obtaining the best possible outcome.

Painting Process



EDUCATE As noted above, bringing the sample board included with your furniture for evaluation in picking paint or stain (with the help of a specialist at a paint, hardware or home center store) is the best way to begin the actual finishing process. Also, read all manufacturer's instructions on the container, clarifying any unclear information and instructions with the paint specialist or by calling or emailing the manufacturer. Labeling on the can should include contact information, or you can search for the manufacturer's website.



PRIME If you are painting the nook, apply primer as directed by the specialist and /or the manufacturer. If you are using a stain, **DO NOT PRIME**. In any case, please follow stain manufacturer's guidelines.



PAINT OR STAIN After the primer has dried, apply paint as directed. When painting and staining, entirely cover all surfaces. Please note on application, the surfaces may take on a spotty and /or streaky appearance as paint or stain soaks into the wood. Do not apply additional paint or stain to the first coat after the surfaces are completely covered or drips may result. The best final finish requires applications of multiple coats.



SAND AGAIN After the first coat has dried, hand sand the entire surface using a fine grit sanding sponge or sandpaper. This step is critical to getting a pro-quality final finish.



CLEAN Equally critical, once everything is sanded, vacuum again to remove all dust.



SECOND COAT Continue to the second coat, applying additional coats as desired. After the final coat has dried, lightly sand with ultra fine sanding sponge or sandpaper.



FINISH When done painting and sanding, choose the final finishing material. Follow recommendations and all instructions included with the wax or varnish.



ASSEMBLE Now, you can assemble your furniture knowing that the finish is going to make the best contribution to the final appearance it can.



IMPORTANT Keep extra stain or paint for touch-ups after the piece is completely dry and assembled. Use a small paintbrush to touch up areas that need it, particularly around screws and nails.

As a favor, please follow us on Instagram at [linonpowellhome!](#)

Congratulations on completing your personally customized furniture piece, something you can proudly display and even post online! We would LOVE to see your beautiful new kitchen nook. Please post online and remember to tag us using [#linonpowellhome](#)

It's your exclusive piece of furniture. Enjoy it! Thanks again for picking Linon to get you started!

PART LIST / LISTE DES PIÈCES / LISTAS DE PIEZAS

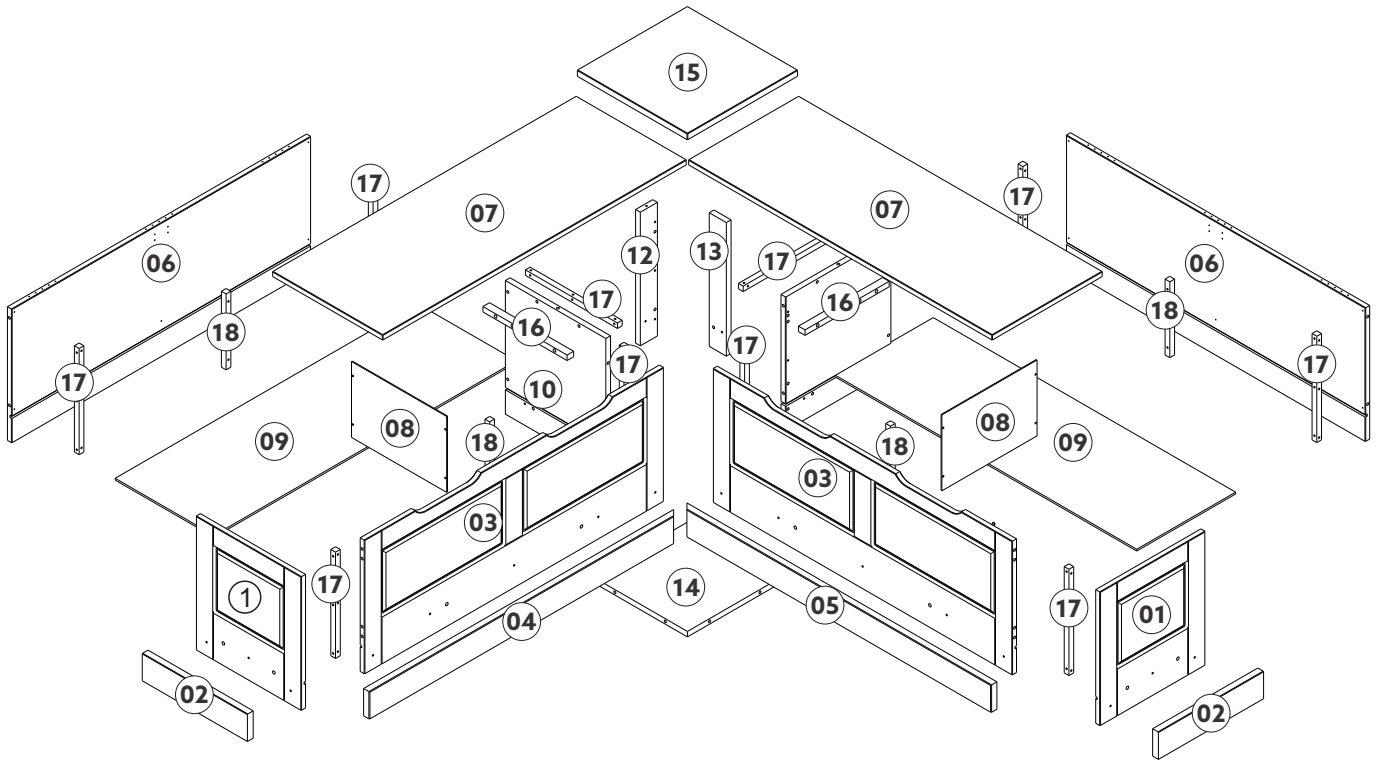

SPARE PARTS - AVAILABLE FOR REPLACEMENT

PIÈCES DE RECHANGE - DISPONIBLES POUR REMPLACEMENT

PIEZAS DE REPUESTO - DISPONIBLES PARA REMPLAZO

903011UNF-01-BR4	Side Panel / Panneau Latéral / Panel Lateral	02
903011UNF-02-BR4	Side Skirting Board / Plinthe Latérale / Zócalo Lateral	02
903011UNF-03-BR4	Front Panel / Panneau Avant / Panel Frontal	02
903011UNF-04-BR4	Left Skirting Board / Plinthe Gauche / Zócalo Izquierdo	01
903011UNF-05-BR4	Right Skirting Board / Plinthe Droite / Zócalo Derecho	01
903011UNF-06-BR4	Back Panel / Panneau Arrière / Panel Trasero	02
903011UNF-07-BR4	Seat / Siège / Asiento	02
903011UNF-08-BR4	Division / Division / División	02
903011UNF-09-BR4	Bottom / Bas / Fondo	02

SPARE PARTS - AVAILABLE FOR REPLACEMENT

PIÈCES DE RECHANGE - DISPONIBLES POUR REMPLACEMENT

PIEZAS DE REPUESTO - DISPONIBLES PARA REMPLAZO

903011UNF-10-BR4	Left Corner Panel / Panneau de Coin Gauche / Panel de Esquina Izquierdo	01
903011UNF-11-BR4	Right Corner Panel / Panneau de Coin Droit / Panel de Esquina Derecho	01
903011UNF-12-BR4	Side Rail / Rail Latéral / Travesaño Lateral	01
903011UNF-13-BR4	Back Rail / Rail Arrière / Travesaño Trasero	01
903011UNF-14-BR4	Corner Bottom / Inférieur de Coin / Fondo de Esquina	01
903011UNF-15-BR4	Corner Top / Supérieur de Coin / Parte Superior de la Esquina	01
903011UNF-16-BR4	Cleat / Taquet / Soporte	02
903011UNF-17-BR4	Corner Cleat / Taquet de Coin / Soporte de Esquina	10
903011UNF-18-BR4	Central Cleat / Taquet Central / Soporte Central	04
903011UNF-00-BR4	Hardware Pack / Ferrures / Paquete de Herraje	01

HARDWARE LIST / LISTE DES PIÈCES / LISTAS DE PIEZAS

A		Wood dowel (8x30mm) / Goujons de bois / Tarugo de madera	39
B		Screw (3x14mm) / Vis / Tornillo	52
C		Screw (4x30mm) / Vis / Tornillo	97
D		Screw (4x40mm) / Vis / Tornillo	12
E		Felt / Feutre / Fieltro	6
F		Hinge / Charnière / Bisagra	6
G		Articulator / Articulateur / Articulador	2

NOTE: Find the label of "Hardware Enclosed" on one of the carton corner then follow the red ribbon to get the hardware bag.

REMARQUE: Repérez l'étiquette «Quincaillerie Incluse» sur le coin de la boîte, puis suivez le ruban rouge pour récupérer le sac contenant la quincaillerie.

NOTA: Busque la etiqueta "Ferretería Incluida" en una de las esquinas de la caja, luego siga la cinta roja para recuperar la bolsa que contiene la tornillería.

TOOLS REQUIRED / OUTILS REQUIS / HERRAMIENTAS REQUERIDAS

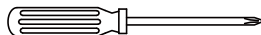
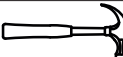
PHILIPS SCREWDRIVER / TOURNEVIS PHILIPS / DESTORNILLADOR ESTÁNDAR		NOT SUPPLIED / NON FOURNI / NO INCLUIDO
HAMMER / MARTEAU / MARTILLO		NOT SUPPLIED / NON FOURNI / NO INCLUIDO

IMPORTANT:

1. Do not tighten bolts completely until all bolts are completely lined up and inserted into holes / nuts.
2. Do not over tighten screws and bolts to avoid stripping.
3. Please use hand tools to assemble this product. Do not use power tools.
4. For ease of assembly, two adults are recommended

IMPORTANT:



1. Ne serrez pas complètement les boulons jusqu'à ce que tous les boulons soient complètement alignés et insérés dans les trous / écrous.
2. Ne pas trop serrer les vis et les boulons pour éviter d'endommager les filets.
3. Utilisez des outils à main pour assembler ce produit. N'utilisez pas d'outils électriques.
4. L'assemblage par deux adultes est recommandé.

IMPORTANTE:

1. No apriete completamente los pernos hasta que todos los tornillos estén alineados completamente y se inserten en los agujeros / tuercas.
2. No apriete demasiado los tornillos y los pernos para evitar dañar los filetes.
3. Utilice herramientas de mano para montar este producto. No utilice herramientas eléctricas.
4. Se recomienda el montaje por dos adultos.

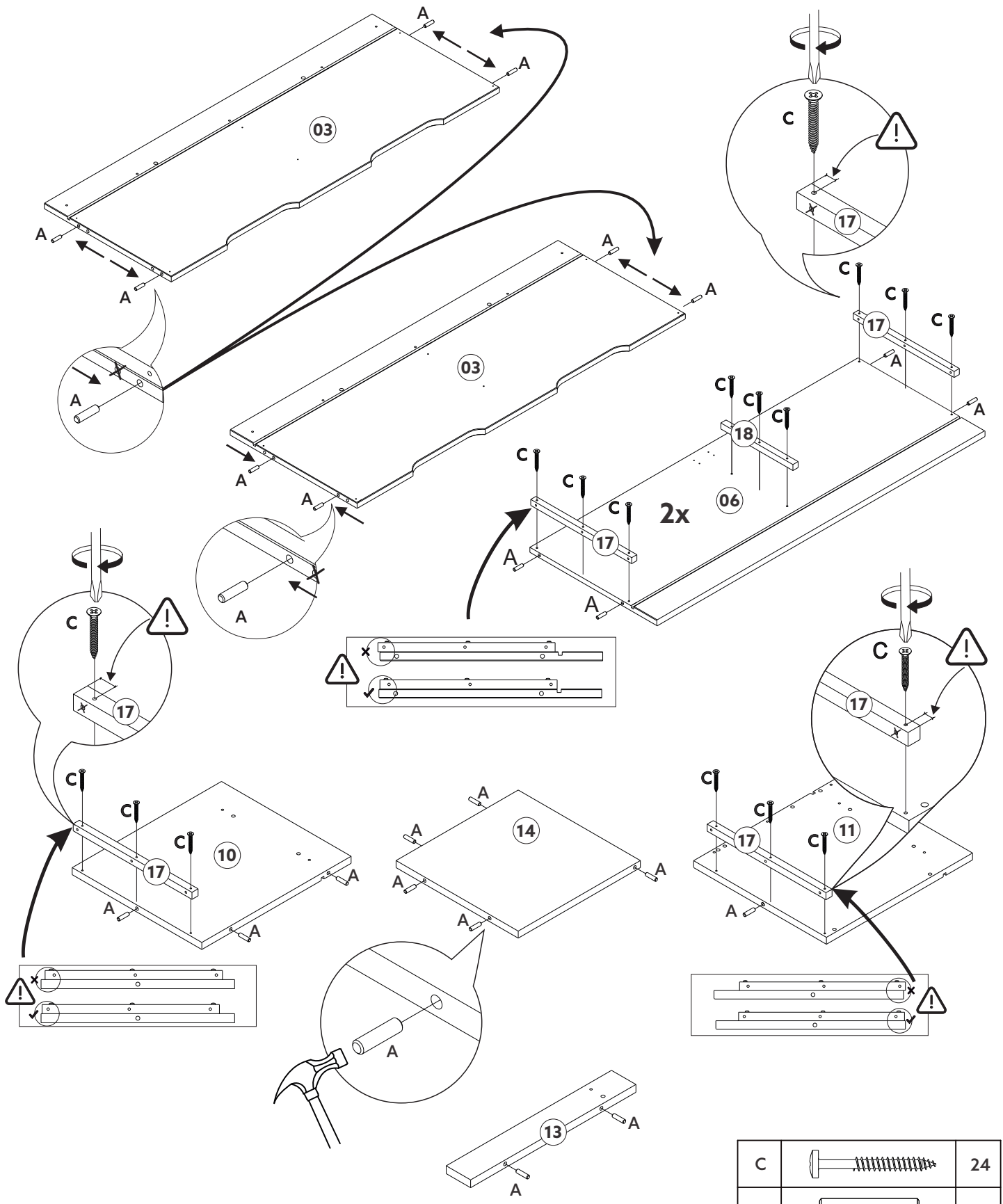
1.

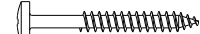

C		24
A		27

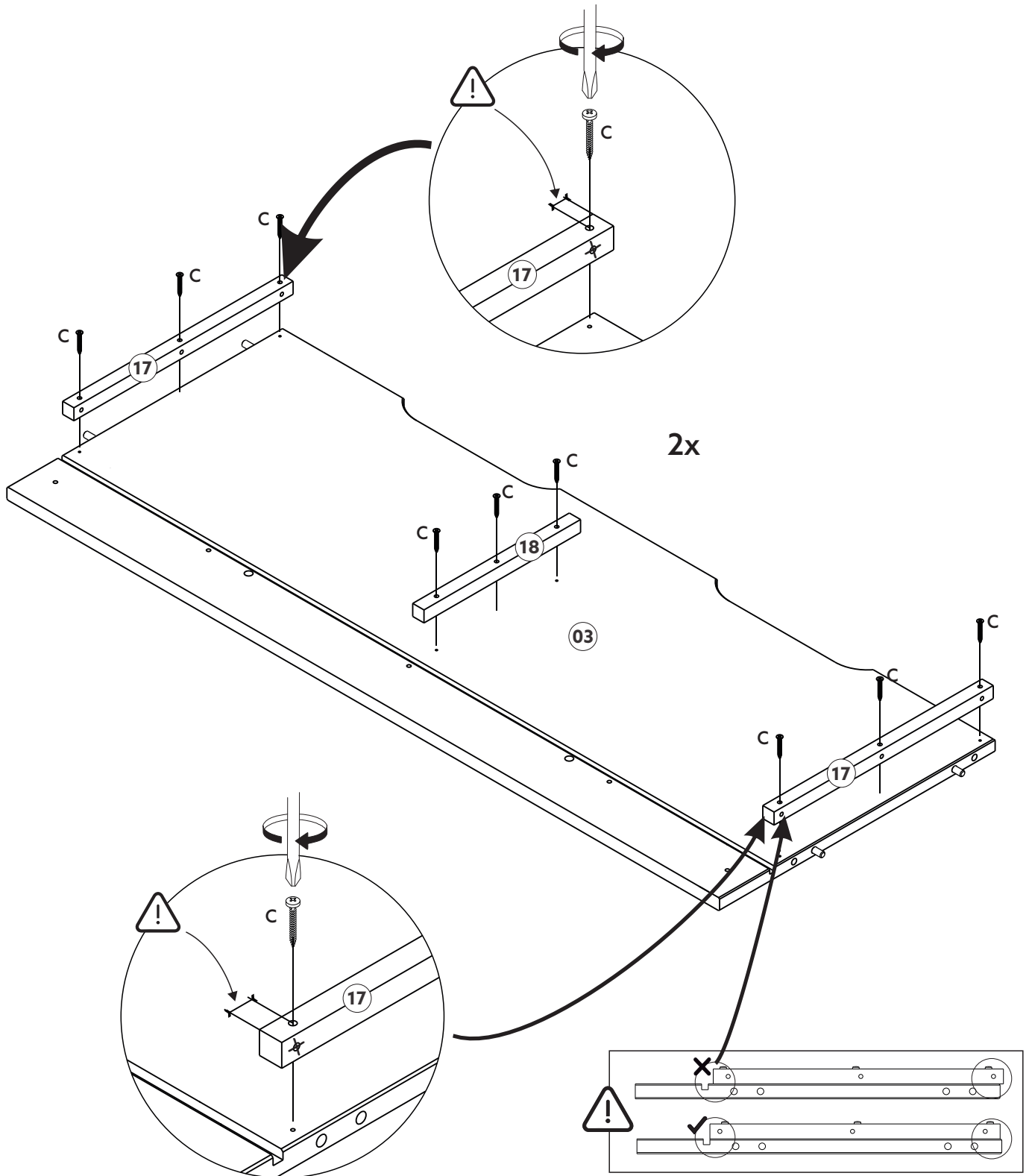

2. USE THE PRE-HOLES FOR ASSEMBLY / UTILISEZ LES PRÉ-TROUS POUR L'ASSEMBLAGE / UTILICE LOS AGUJEROS PREVIOS PARA EL MONTAJE.

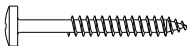

C		18
---	---------------------------------------------------------------------------------------	----

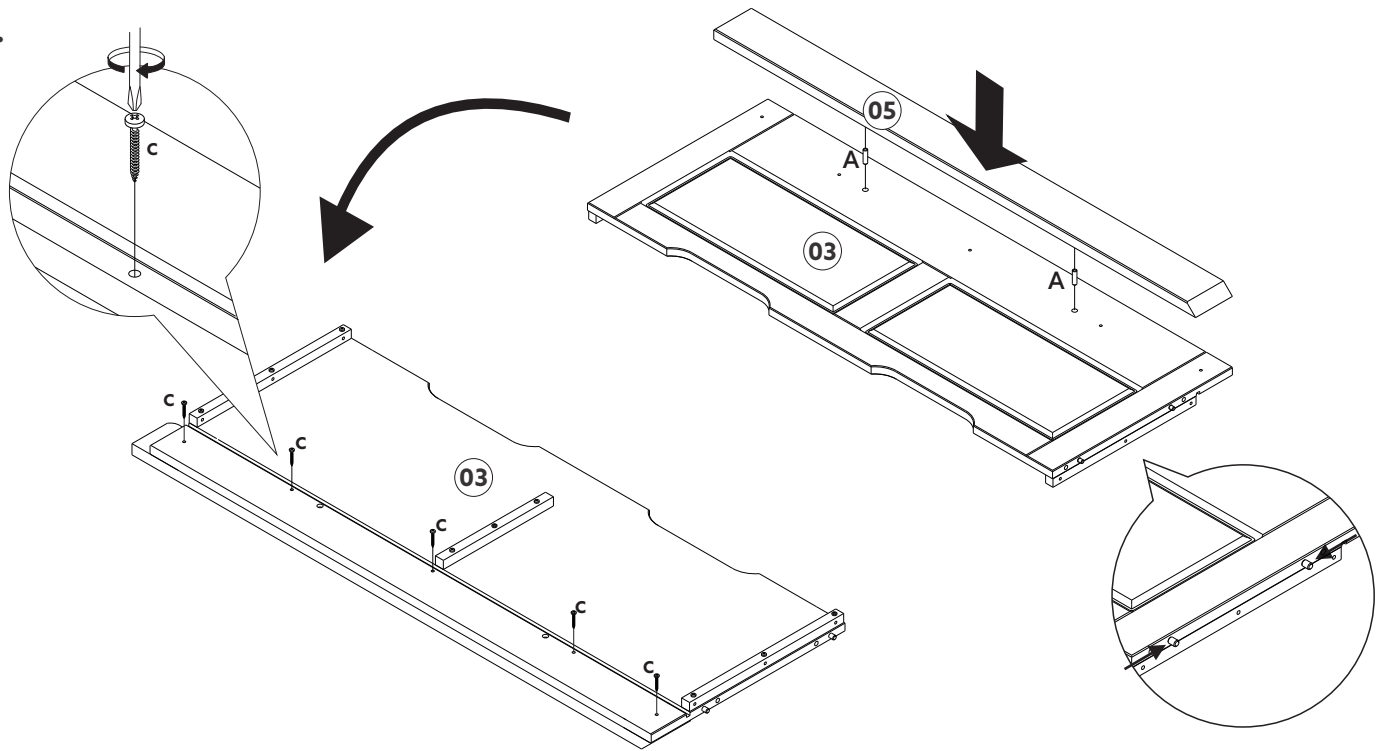

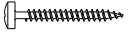
3.



C		5
A		2

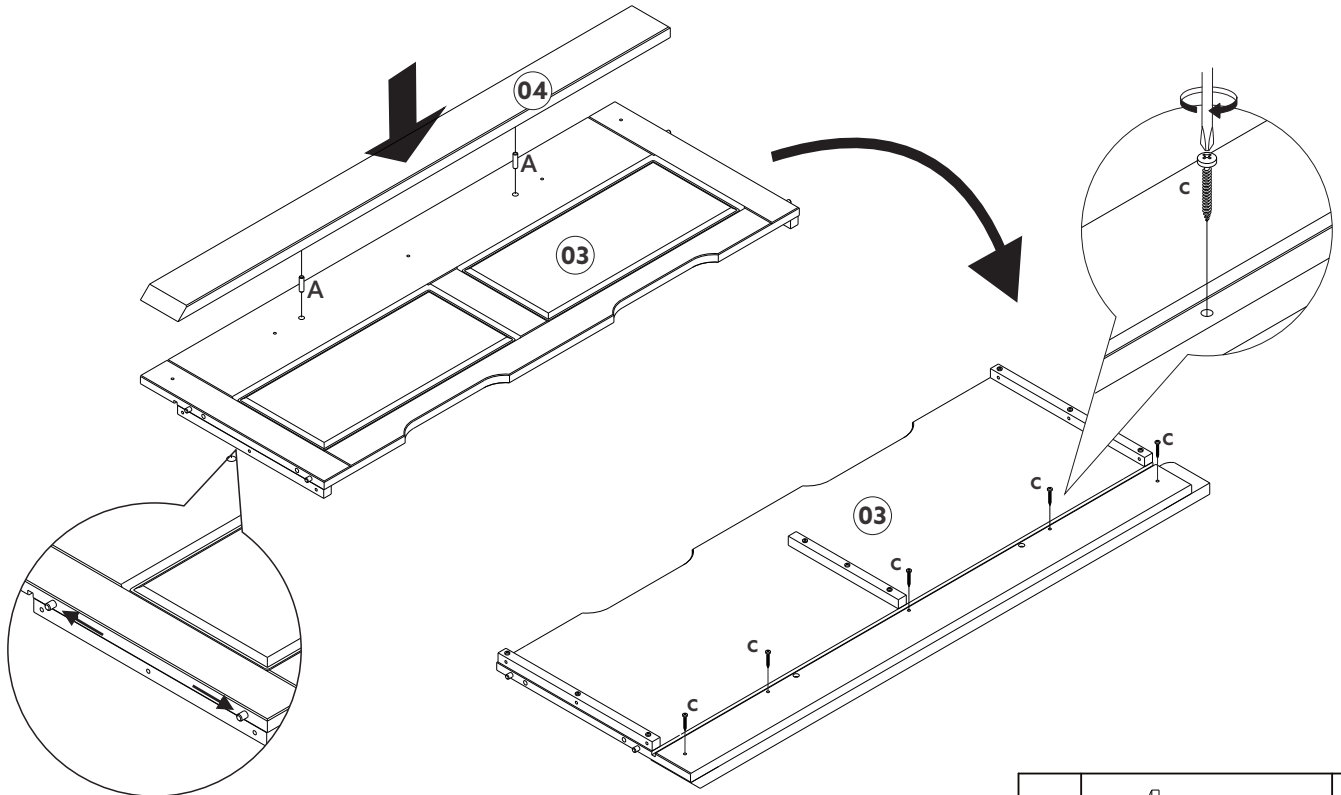

4.

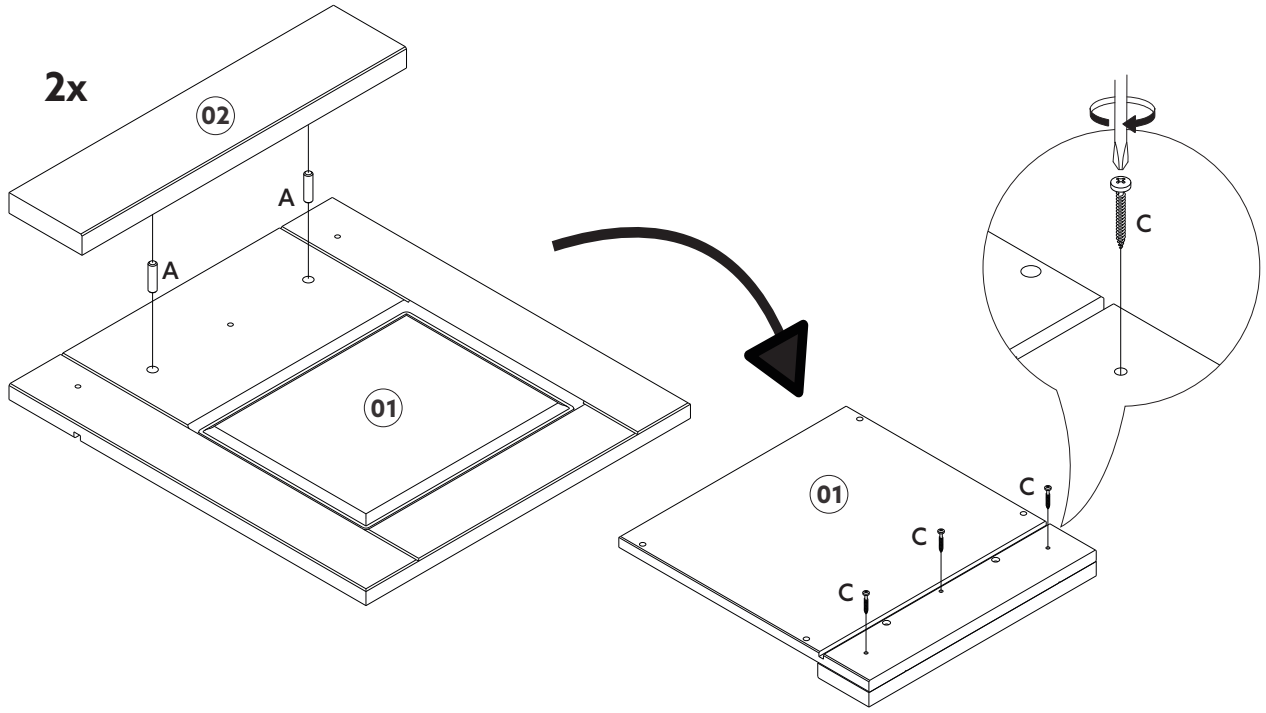

C		5
A		2

5.

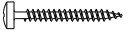

C		6
A		4

6.

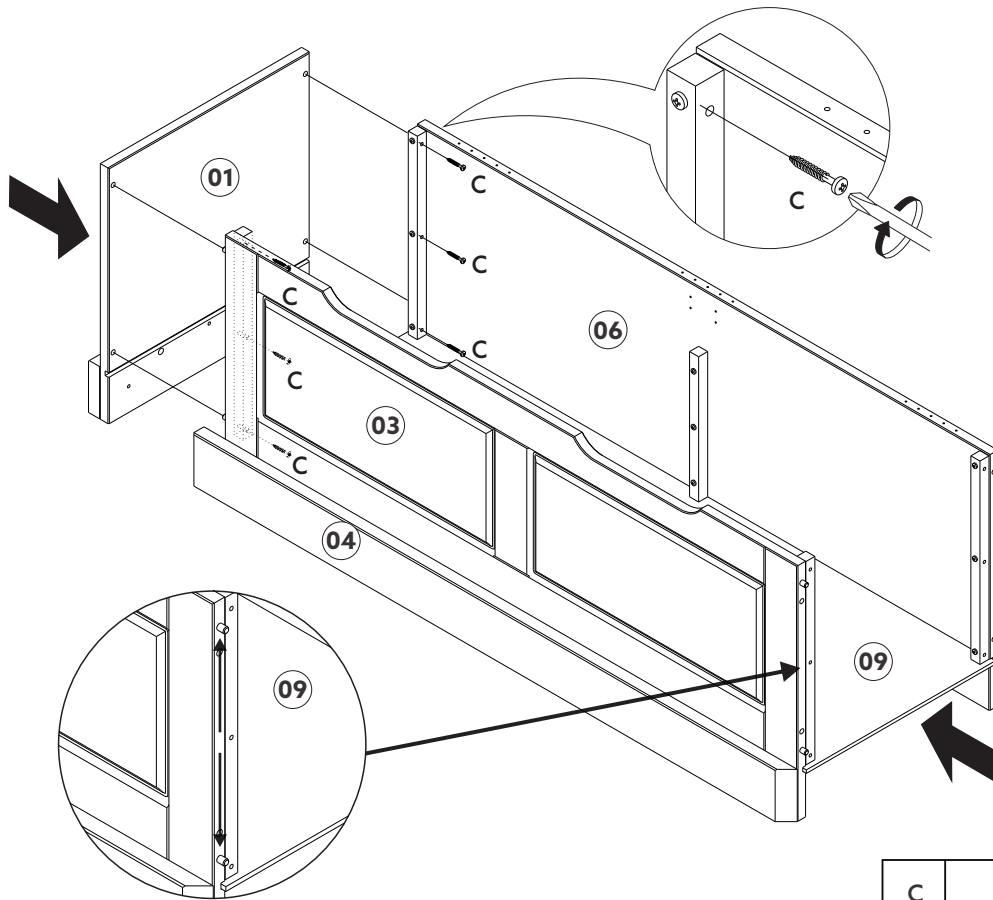

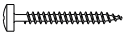
C		6
---	---------------------------------------------------------------------------------------	---

7.

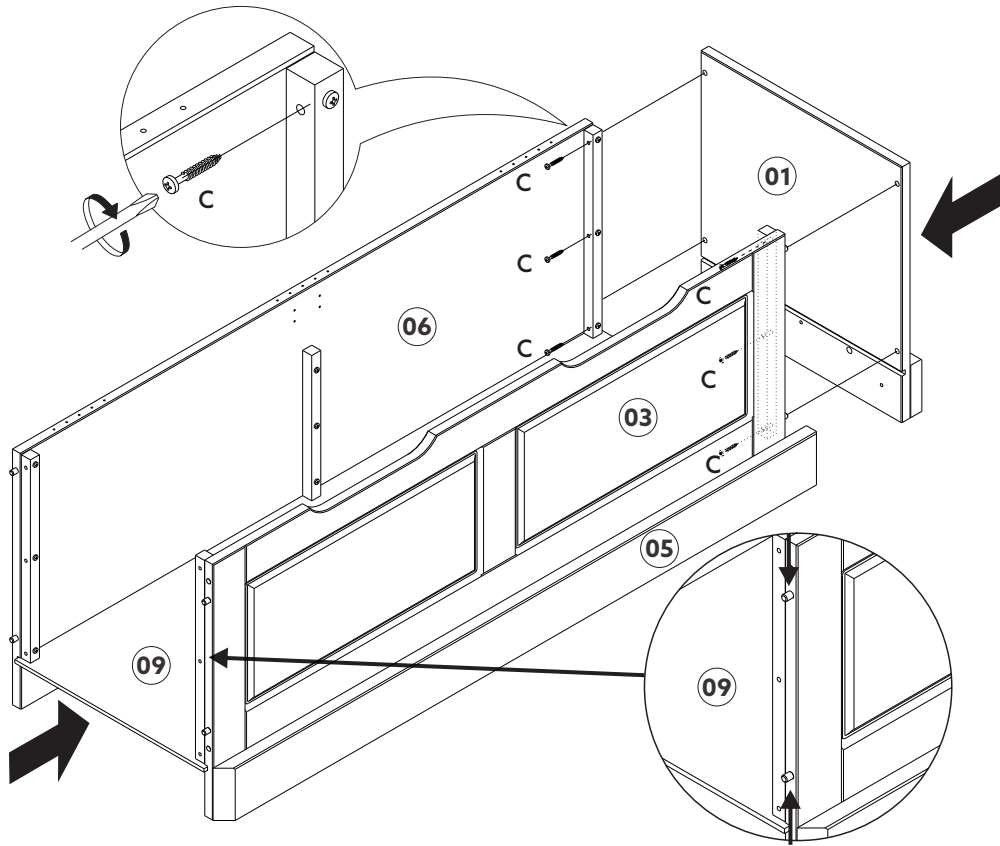

C		6
---	---------------------------------------------------------------------------------------	---

8.

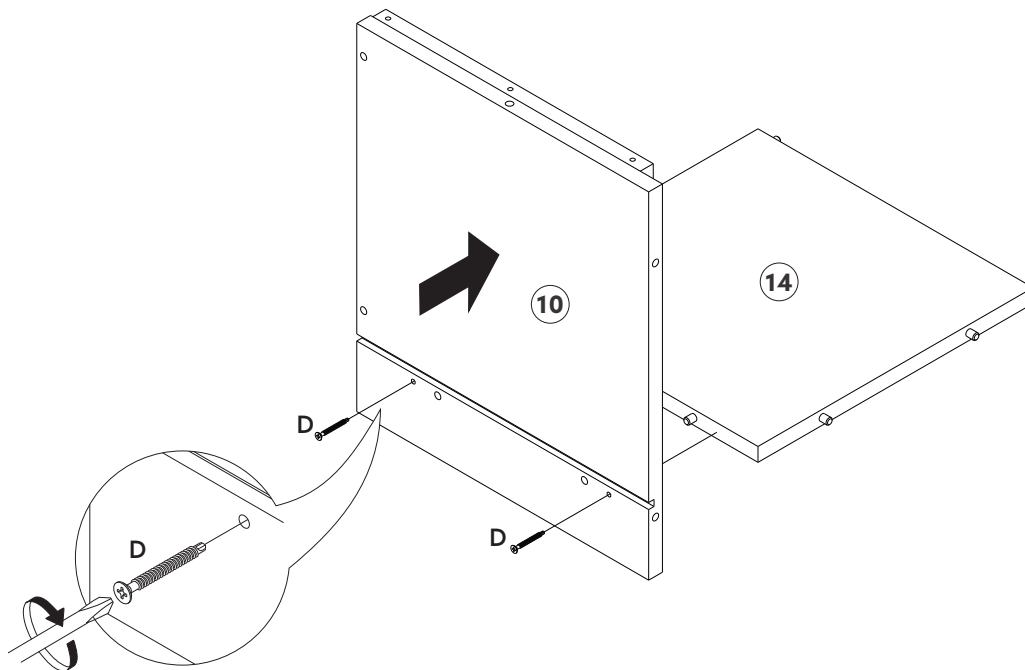

D		2
---	---------------------------------------------------------------------------------------	---

9.

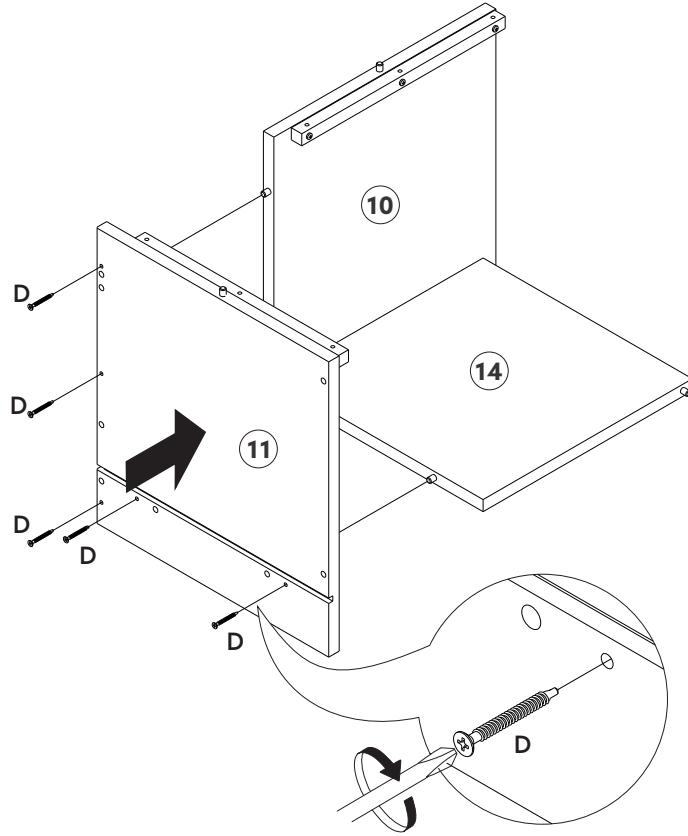

D		5
---	---------------------------------------------------------------------------------------	---

10.

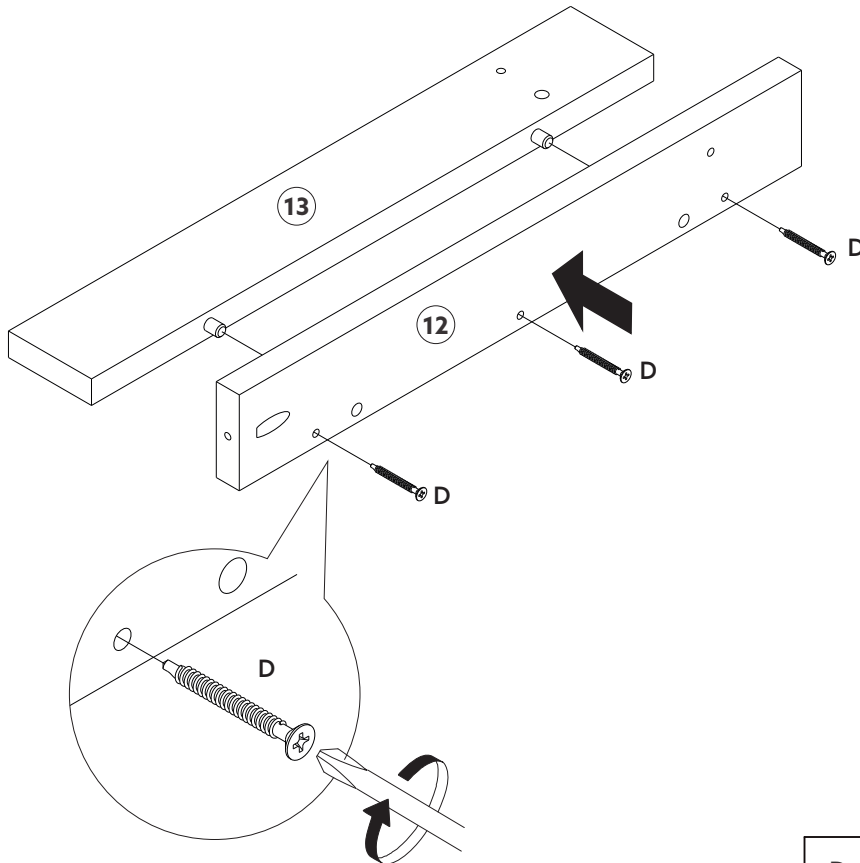

D		3
---	---------------------------------------------------------------------------------------	---

11.

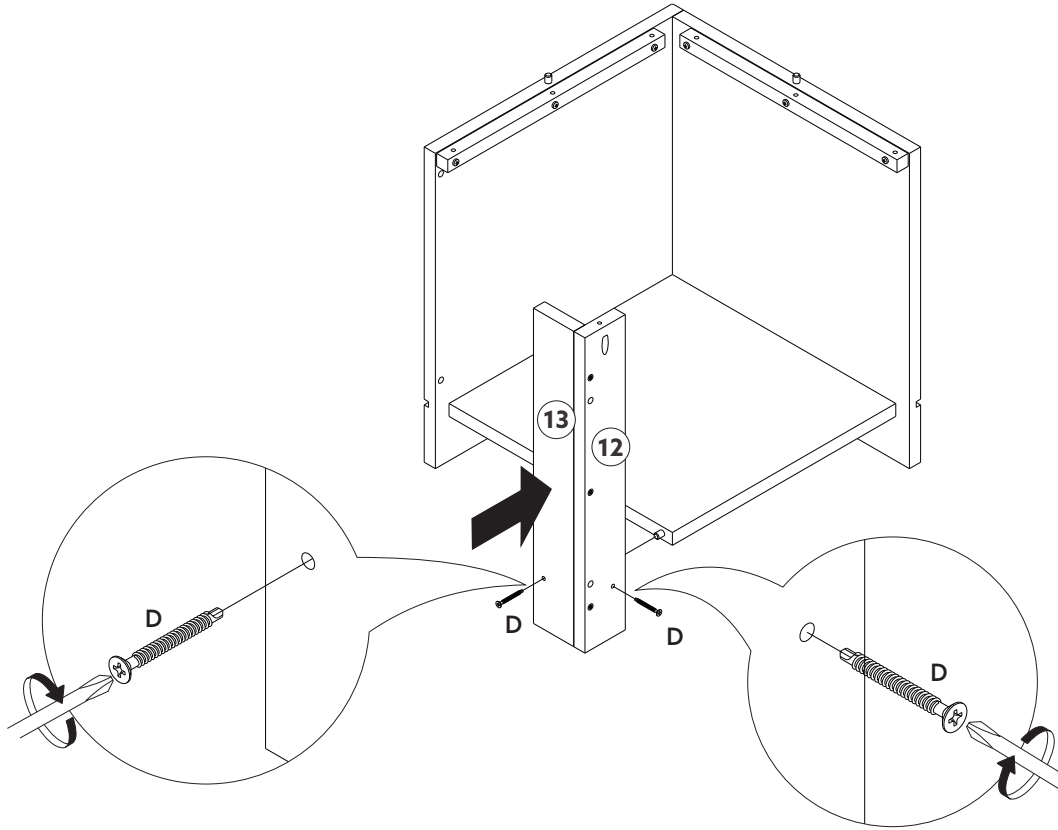

D		2
---	---------------------------------------------------------------------------------------	---

12.

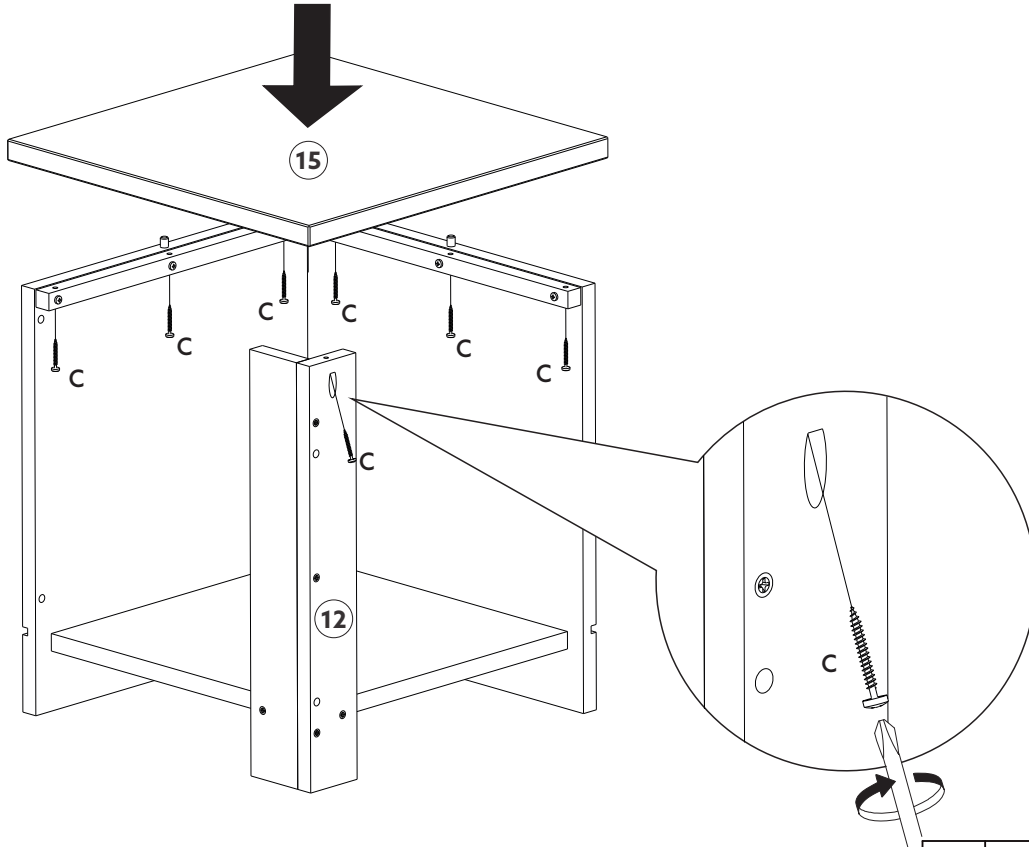

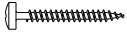
C		7
---	---------------------------------------------------------------------------------------	---

13.

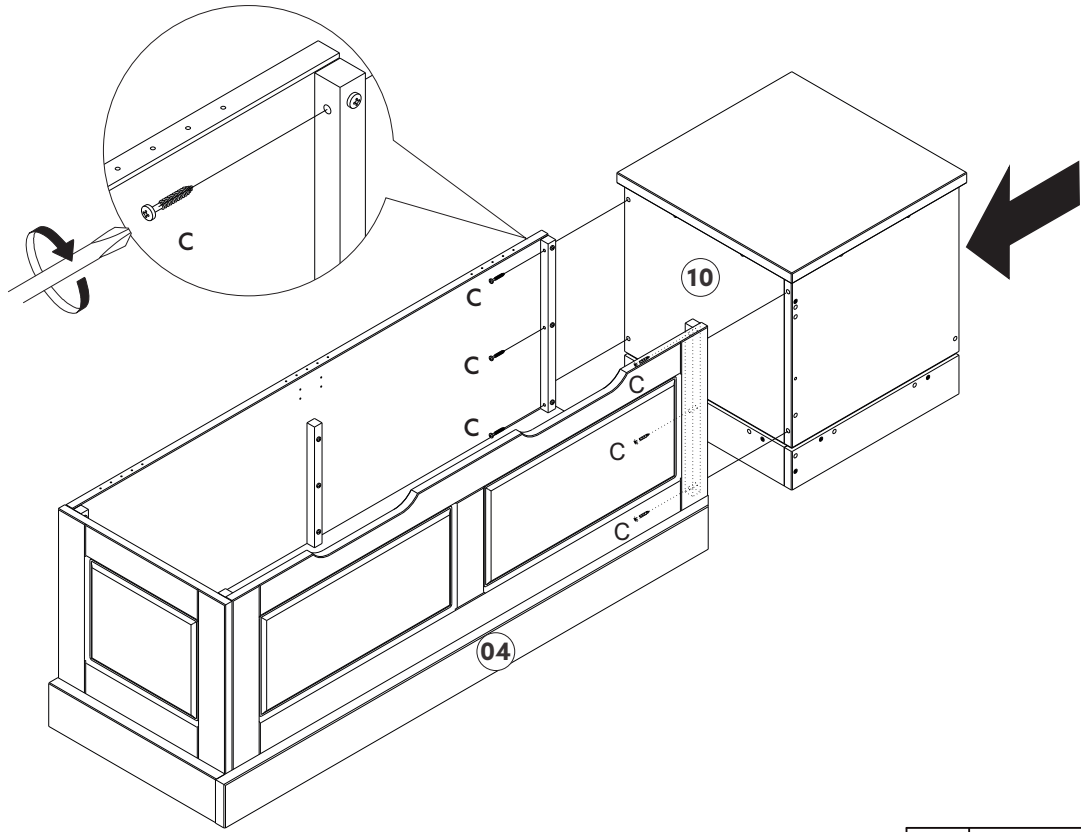

C		6
---	---------------------------------------------------------------------------------------	---

14.

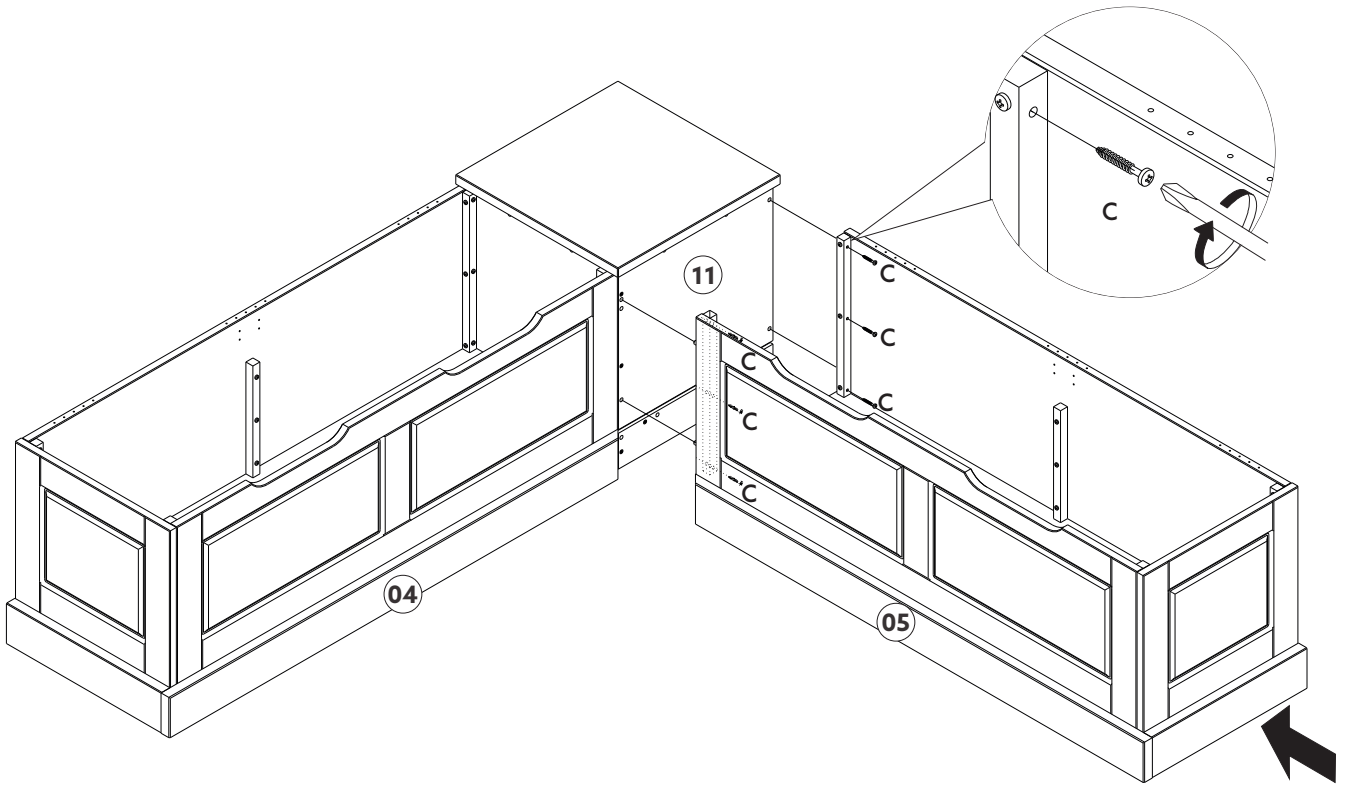

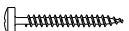
C		6
---	---------------------------------------------------------------------------------------	---

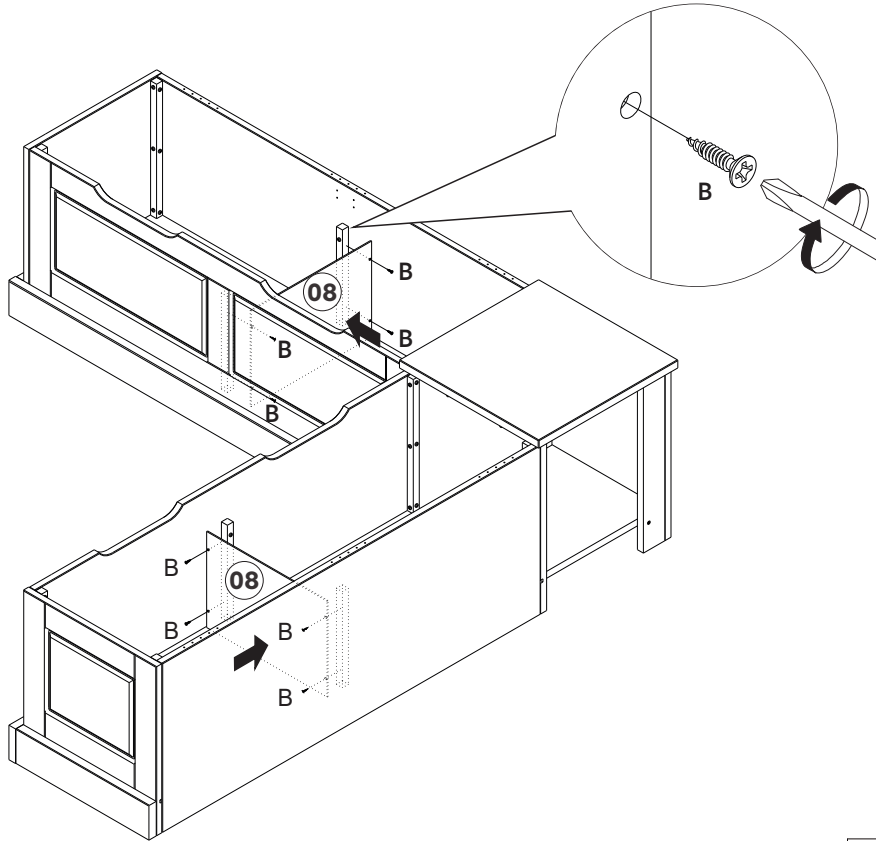

15.

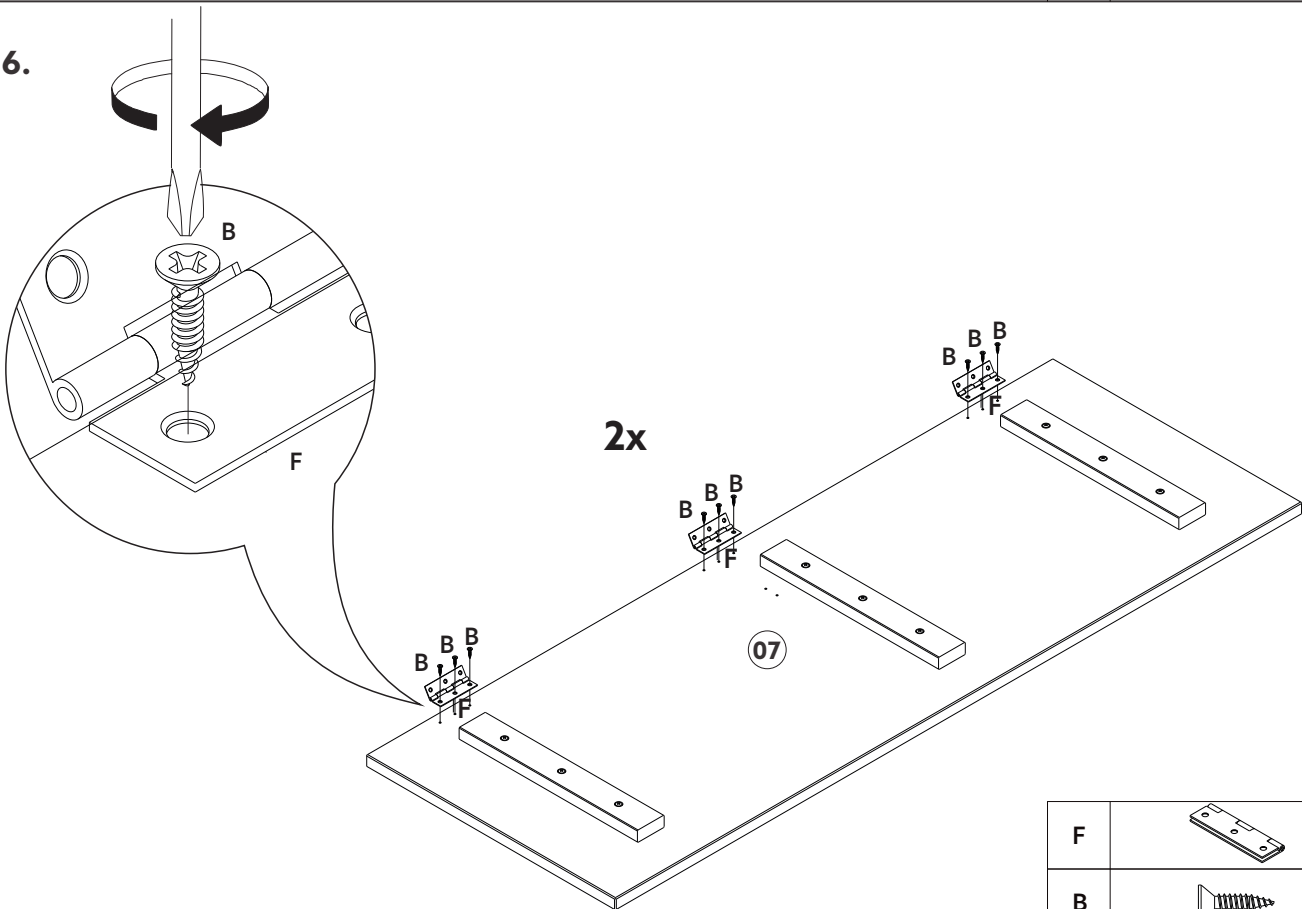

B		8
---	---------------------------------------------------------------------------------------	---

16.



F		6
B		18

17.

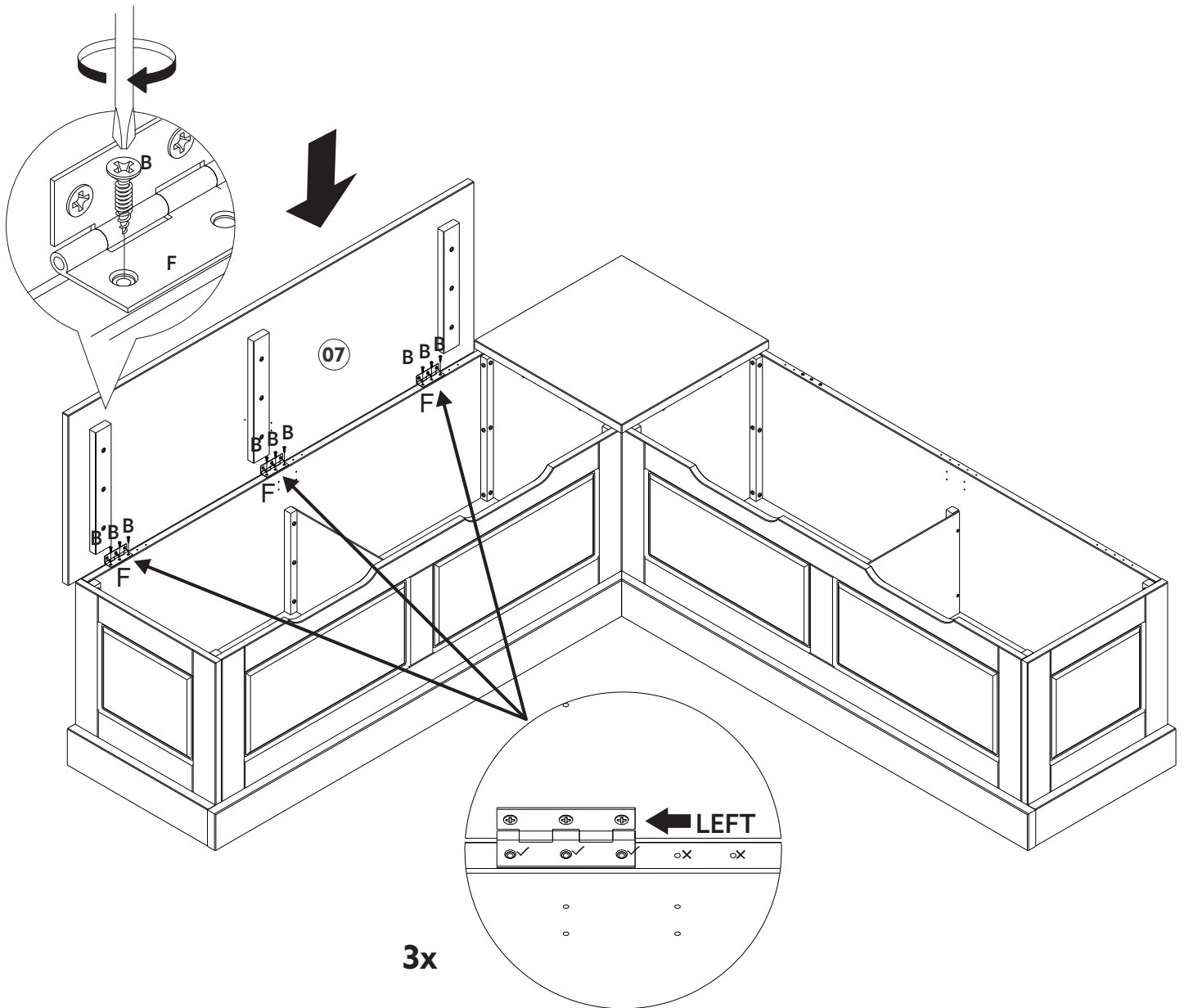

In order not to confuse with similar pieces, there are double holes for the hinges. Please pay attention to fix as per drawing and details.

Afin de ne pas confondre avec des pièces similaires, il y a des doubles trous pour les charnières. Veuillez faire attention à corriger selon le dessin et les détails.

Para no confundir con piezas muy similares, las piezas tienen doble huecos para las bisagras. Por favor, preste atención para fijarlas como los dibujos y detalles.

B		9
---	---------------------------------------------------------------------------------------	---



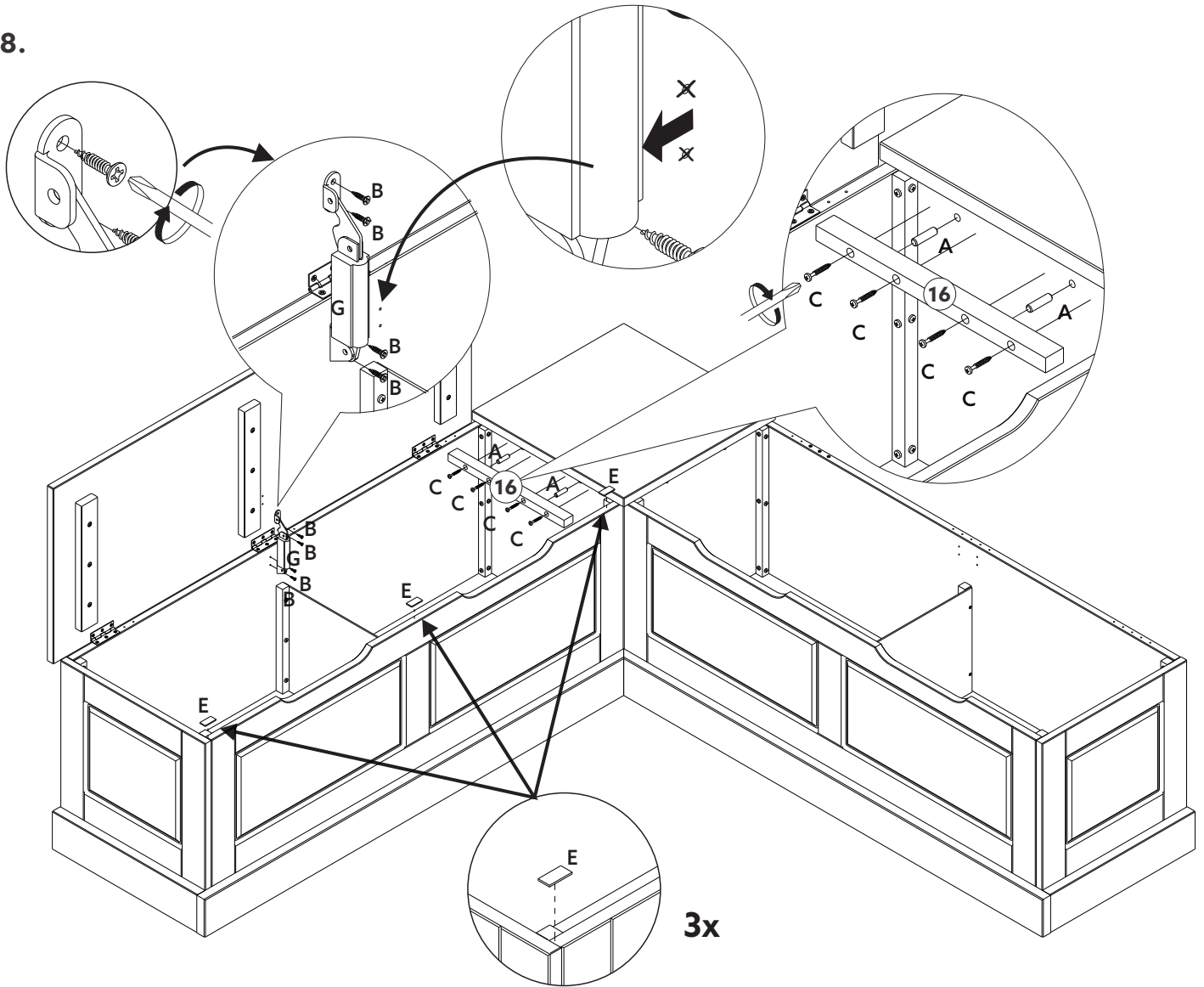

18.

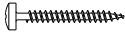

In order not to confuse with similar pieces, there are double holes for the safety hinges. Please pay attention to fix as per drawing and details.

Afin de ne pas confondre avec des pièces similaires, il y a des doubles trous pour les articulateurs. Veuillez faire attention à corriger selon le dessin et les détails.

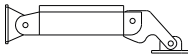
Para no confundir con piezas muy similares, las piezas tienen doble huecos para los articuladores. Por favor, preste atención para fijarlas como los dibujos y detalles.

A		2
C		4
E		3
G		1
B		4

19.

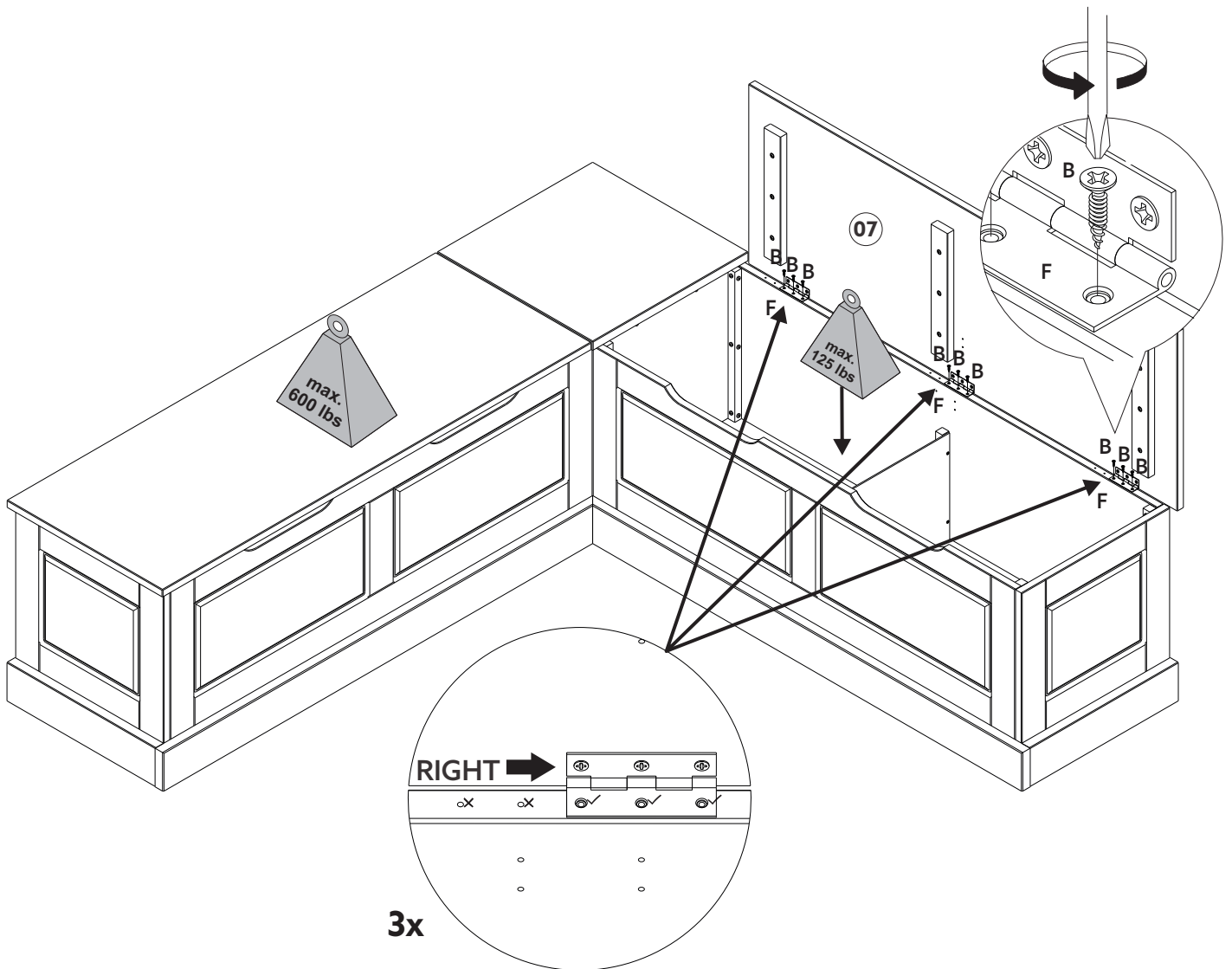

In order not to confuse with similar pieces, there are double holes for the hinges. Please pay attention to fix as per drawing and details.

Afin de ne pas confondre avec des pièces similaires, il y a des doubles trous pour les charnières. Veuillez faire attention à corriger selon le dessin et les détails.

Para no confundir con piezas muy similares, las piezas tienen doble huecos para las bisagras. Por favor, preste atención para fijarlas como los dibujos y detalles.

B		9
---	---------------------------------------------------------------------------------------	---

20.

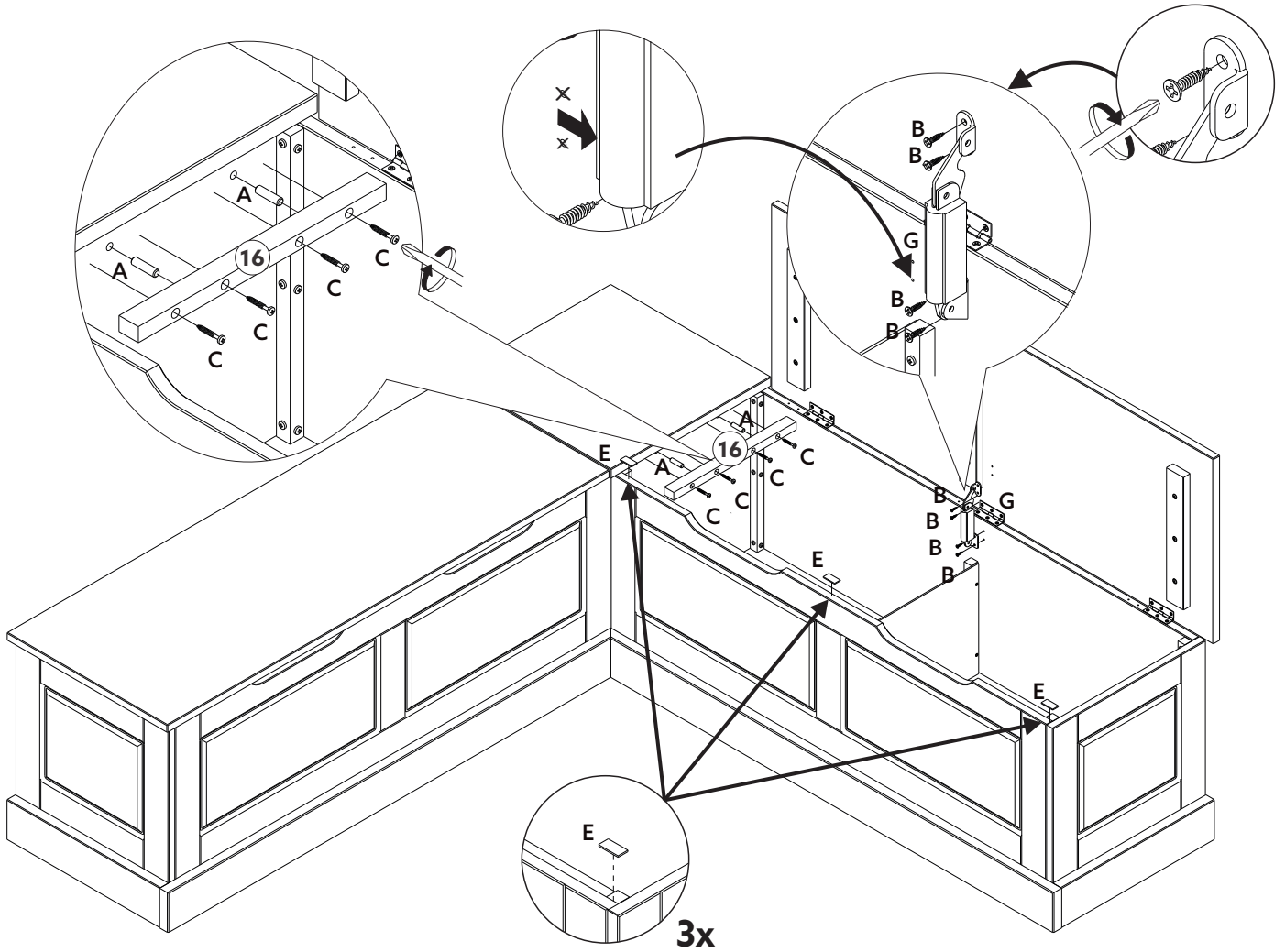

In order not to confuse with similar pieces, there are double holes for the safety hinges. Please pay attention to fix as per drawing and details.

Afin de ne pas confondre avec des pièces similaires, il y a des doubles trous pour les articulateurs. Veuillez faire attention à corriger selon le dessin et les détails.

Para no confundir con piezas muy similares, las piezas tienen doble huecos para los articuladores. Por favor, preste atención para fijarlas como los dibujos y detalles.

A		2
C		4
E		3
G		1
B		4

LIMITED 6 MONTHS WARRANTY

GARANTIE LIMITÉE DE 6 MOIS / GARANTÍA LIMITADA DE 6 MESES

WHAT IS COVERED

This product is covered under our manufacturer's 6 months limited warranty (Linon Home Décor Products). To ensure your complete satisfaction, this warrants to the original purchaser that the Linon supplied item is free from defects in material and workmanship, as of the date of purchase, and that it will, under normal use and proper care, remain so for six months after the date of purchase.

Replacement of missing or initially defective parts will be sent, at no charge, for a period of 30 days from the date of purchase with valid proof of purchase providing the parts are available in our warehouse and the item purchased is part of our current inventory.

QU'EST-CE QUI EST COUVERT

Ce produit est couvert sous une garantie limitée de 6 mois offerte par le fabricant. Afin d'assurer votre entière satisfaction, cela garantit à l'acheteur original que le produit fourni est exempt de défauts de matériaux et de fabrication à compter de la date d'achat.

Le remplacement de pièces manquantes ou défectueuses des le départ sera envoyé, sans frais, pour une période de 30 jours suivant la date d'achat avec une preuve d'achat valide pourvu que les pièces soient disponibles dans notre entrepôt et que l'article acheté fait partie de notre inventaire actuel.

QUÉ ESTÁ CUBIERTO

Este producto está cubierto por la garantía limitada de 6 meses de nuestro fabricante. Para asegurar su total satisfacción, ésta garantiza al comprador original que el artículo proporcionado se encuentra libre de defectos materiales y de fabricación, a partir de la fecha de compra, y que permanecerá en tal estado, sometido a un uso normal y cuidados adecuados, durante los seis meses posteriores a la fecha de la compra.

Las partes faltantes o que presenten defectos al inicio de ese período de tiempo serán enviadas sin cargo, durante un lapso de 30 días a partir de la fecha de compra, mediante la presentación de un comprobante de compra válido, siempre que las partes estén disponibles en nuestro almacén y el artículo adquirido sea parte de nuestro inventario actual.

WHAT IS NOT COVERED

It remains the customer's responsibility for freight and packaging charges to and from the customer service center. Labor and material charges to remove or replace parts under this warranty are not covered.

This warranty does not cover: Furniture used for commercial purposes, failures caused by improper installation assembly or by improper care, unreasonable or abusive use, freeze damage, acts of God, rust, purchased parts or return freight and packaging charges. Proof of purchase (dated register receipt) is required for warranty claims.

QU'EST-CE QUI N'EST PAS COUVERT

Il y va de la responsabilité du client de couvrir les frais de transport et d'emballage vers et à partir du centre de service après-vente. Les frais de la main-d'œuvre et des matériaux pour retirer les pièces ou les remplacer sous cette garantie ne sont pas couverts.

Cette garantie ne couvre pas : les meubles utilisés à des fins commerciales, les défaillances causes par un mauvais assemblage ou entretien (sans dépasser les limites de poids), l'utilisation déraisonnable ou abusive, les dommages causées par le gel, la rouille, les frais de transport et d'emballage pour des pièces achetées ou retournées. Une preuve d'achat (reçu de caisse date) est requise pour les réclamations sous garantie.

QUÉ NO ESTÁ CUBIERTO

El cliente asumirá los costos de flete y empaque hacia y desde el centro de servicio de cliente. Los cargos de material y mano de obra para extraer o reemplazar partes en el marco de la garantía no están cubiertos.

Esta garantía no cubre: muebles utilizados con fines comerciales, fallas causadas por montaje de instalación inadecuados o uso indebido (se recomienda no exceder los límites de peso), uso no razonable o abusivo, daños por congelación, oxidación, partes compradas, flete de devolución y cargos de empaque. Se exigirá el comprobante de compra (la factura de registro con fecha) para hacer valer la garantía.

HOW TO OBTAIN SERVICE

For further information, please contact our customer service department, c/o Linon Home Décor Products, Inc., between 9:00 AM and 5:00 PM EST, Monday through Friday:

Email address: consumersupport@linon.com

COMMENT FAIRE POUR OBTENIR DU SERVICE

Pour de plus amples renseignements, veuillez communiquer avec notre département du service à la clientèle, entre 9 h et 17 h HNE, du lundi au vendredi.

Adresse de courriel : consumersupport@linon.com

CÓMO OBTENER SERVICIO

Si desea más información, póngase en contacto con nuestro departamento de servicio al cliente, de lunes a viernes entre las 9:00 a.m. y las 5:00 p.m., hora estándar de los Estados Unidos.

Correo electrónico: consumersupport@linon.com

MADE IN BRAZIL
FABRIQUE EN BRÉSIL
HECHO EN BRASIL

ITEM# 903011UNF01U
BR4 - 20236

INSTAGRAM: @LINONHOMEDÉCOR
TWITTER: LINON HOME DÉCOR

THANK YOU FOR YOUR PURCHASE!

We LOVE seeing our products in your home. Take a photo and share it with us using the hashtag #LinonLiving for a chance to be featured on our Instagram!

FACEBOOK: LINON HOME DÉCOR
PINTEREST: LINON HOME DÉCOR





NORAH BACKLESS NOOK UNFINISHED
NORAH COIN SANS DOSSIER INACHEVÉ
NORAH BANCO ESQUINERO SIN ESPALDA SIN ACABADO

ITEM# 903011UNF01U