

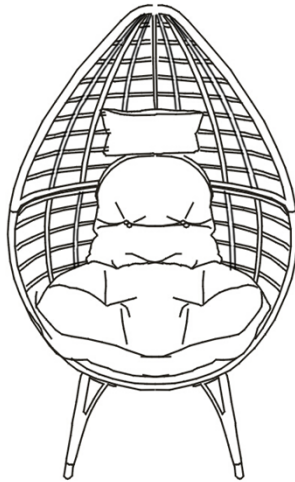



# Assembly Instructions

Caution: You must read this before you proceed.

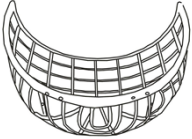
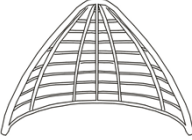

## Basket Chair

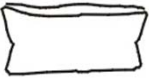

## Parts List

Label	Picture	Description	QTY
A		Basket Seat	1
B		Basket Top	1
C		Front Leg (C1)	2
D		Back Leg (C2)	2
E		Pillow	1
F		Cushion	1

# Hardware

Label	Picture	Description	QTY
G		Allen Key	1
H		Bolt with Washer (M6x16MM)	13
I		Bolt with Washer (M6x30MM)	5

## Assembly Preparation

Before Beginning Assembly:

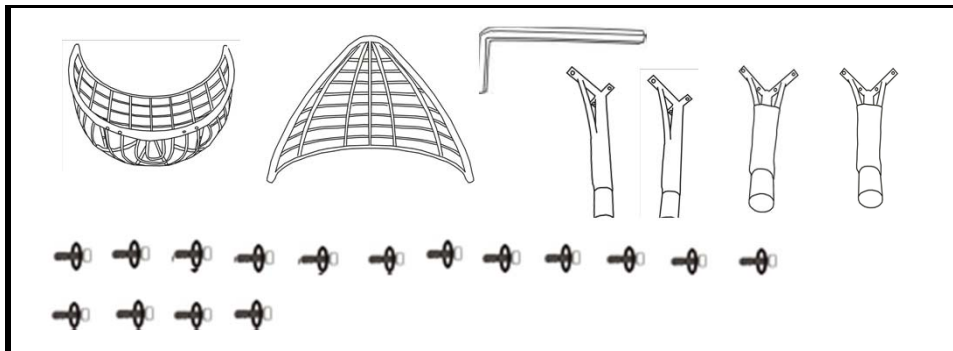

- Read instructions, cover to cover-



- Have 2 adults on hand for assembly-



- Do not assemble on flooring or carpet-



- Assemble on a clean non-marring surface (packing foam)-



- Save all packaging until finished-

## Assembly Steps

### Step 1

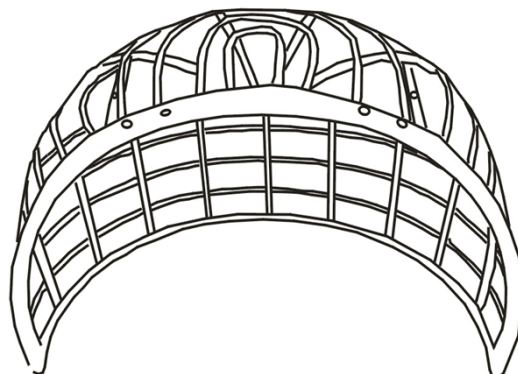

Open the carton and place all the parts onto a clean, non-marring surface.  
Place Basket Seat(A) on the ground, as shown in picture above.

## Step 2

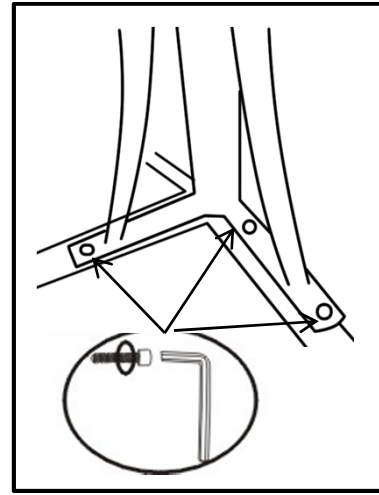
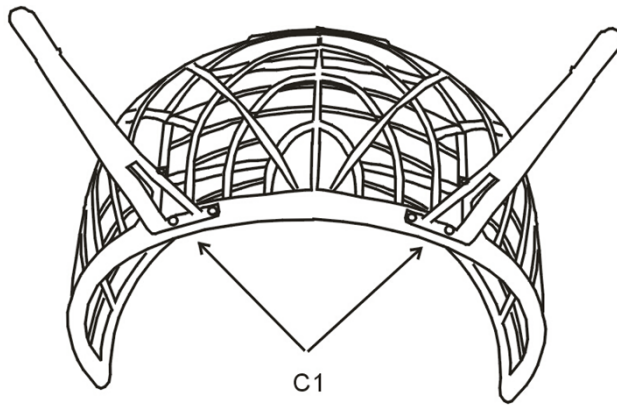

Attach two Front Legs(C1) to the Basket Seat(A) using Bolts with Washers(H) with Allen Key(G) as shown in the picture above.

**Loosely tighten the Bolts.**

## Step 3

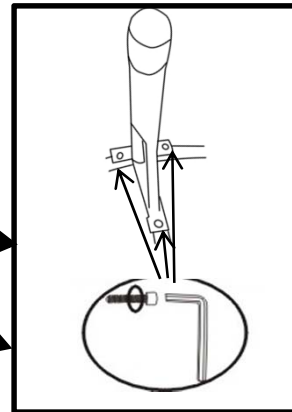
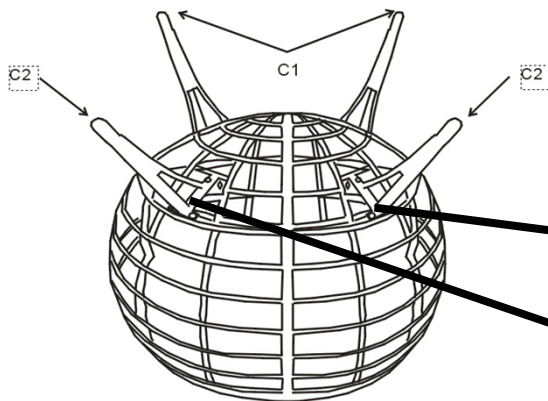

Turn the Basket Seat(A) around as shown in picture.

Attach Back Legs(C2) to Basket Seat(A) using Bolts with Washers(H) with Allen Key(G) as shown in picture above.

**Loosely tighten the Bolts.**

## Step 4

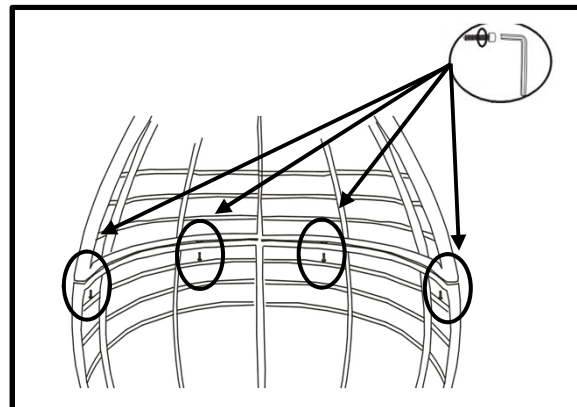
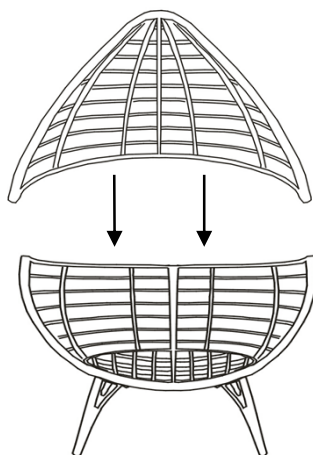

Stand the Basket Seat(A) upright.

Attach the Basket Top(B) to the Basket Seat(A) using Bolts with Washers(I) with Allen Key(G) as shown in picture above.

**Loosely tighten the Bolts.**

**Caution: Two or three adults partners are required for assembly at this step.**

## Step 5

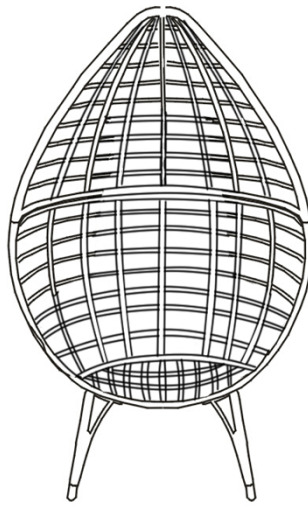

Check for stability and then tighten all Bolts at all joints.

**Note: DO NOT fully tighten a Bolt in one go and then move on to the next.**

**Rather; in a sequential manner, gradually tighten each Bolt until all Bolts are evenly secured.**

**This methodology will ensure maximum evenness once all Bolts are fully tightened.**

## Step 6

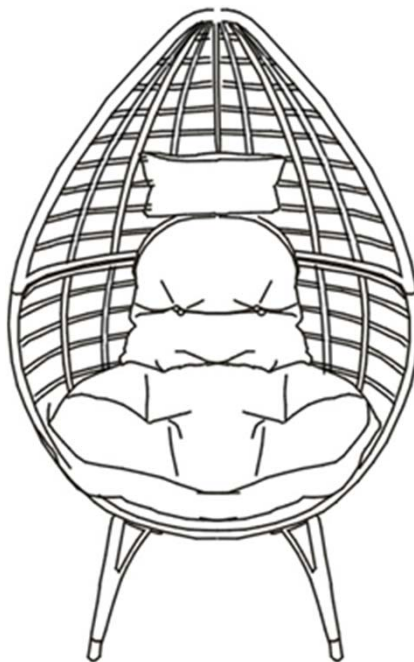

Place the Cushion(F) and Pillow(E) on the Basket.  
Your Basket Chair is ready for use.

## Care & Maintenance



- Do not put hot items directly on furniture surface.



- Do not clean furniture with harsh cleansers or polish.



- To obtain the longest lifespan of your outdoor products, minimizing exposure to direct sunlight is recommended.



- Children should not climb or jump on the furniture.



- Do not write on furniture without a padded barrier to protect the surface.



- To obtain the longest lifespan of your outdoor products, avoid extended and lengthy exposure to rain, snow, and direct sunshine. Whenever possible cover the product and /or place under patio or awnings.



- Not for commercial use. For residential use only .



- Stains may be removed with mild soap solution and damp cloth.



- Keep away from sources of ignition.



- Dust and pick-up spills using a clean, non-colored, lint-free cloth .