



Doosan Infracore
Portable Power

OPERATION and MAINTENANCE MANUAL

COMPRESSORS MODEL:

C185WDO-T4F (G87)



This manual contains important safety information.
Do not destroy this manual.
This manual must be available to the personnel who operate and
maintain this product.

Doosan Infracore Portable Power
1293 Glenway Drive
Statesville, N.C. 28625
DoosanPortablePower.com

P/N: 46738526 (2018) Rev B



WARNING: Breathing diesel engine exhaust exposes you to chemicals known to the State of California to cause cancer and birth defects or other reproductive harm.

- Always start and operate the engine in a well-ventilated area.
- If in an enclosed area, vent the exhaust to the outside.
- Do not modify or tamper with the exhaust system.
- Do not idle the engine except as necessary.

For more information go to www.P65warnings.ca.gov/diesel.



WARNING: This product can expose you to chemicals including lead, which is known to the State of California to cause cancer and birth defects or other reproductive harm.

For more information go to
www.P65warnings.ca.gov.

TABLE OF CONTENTS
Operation & Maintenance Manual

TITLE	PAGE
.....	iii
FOREWORD	9
Information	10
DRAWBAR INSTRUCTIONS.....	13
Instruction Kit For Drawbar	14
SAFETY	17
Safety Precautions	18
Compressed Air.....	19
Exhaust System	20
Materials.....	20
Battery	21
Coolant System.....	22
Transport	22
Decals.....	24
NOISE EMISSION.....	27
Noise Emission.....	28
Compressor Noise Emission Control Information	28
Maintenance Log	29
Noise Emission Warranty	29
Introduction	30
Maintenance Schedule.....	30
GENERAL DATA	33
General Data Information.....	34
Expendable Service Parts	34
OPERATING INSTRUCTIONS	37
Control Panel.....	38
Control Panel Gauges.....	38
Quick View Screens.....	39

TABLE OF CONTENTS

Operation & Maintenance Manual

TITLE	PAGE
Fault and Alert	40
Service Interval Setup	42
Languages and Units	44
Display Setup	45
Display Compressor and Display Software Information	45
Display Compressor and Display Software Information	46
Before Towing.....	47
Setting Up	48
Towing	49
Before Starting	49
Starting	50
Shutdown.....	52
Pressure Regulator Adjustment Instructions	53
ENGINE OPERATION.....	55
Engine Operation and Maintenance.....	56
Safety	57
Instructions	58
General Repair	61
Environmental Pollution	62
Engine Management.....	63
Prevention of Pollution	65
Start and Shutdown	66
Break-in Period of Engine.....	67
Inspection after Starting the Engine	69
Operation in Winter.....	70
Regular Inspection	71
Checking the Engine Oil.....	72
Checking the Oil Level Gauge	73
Replacement of Engine Oil.....	75
Coolant	79
Checking the Coolant.....	80
Replenishment of Coolant	83
Replacement of Coolant.....	84
LUBRICATION	87
Lubrication	88
Compressor Oil Chart	88
MAINTENANCE.....	91

TABLE OF CONTENTS
Operation & Maintenance Manual

TITLE	PAGE
General Information	92
Compressor Oil Filters	95
Receiver Separator System.....	96
Scavenge Line	97
Exterior Finish Care	97
Field Replacement of Exterior Decals	98
Preventive Maintenance Schedule	99
TROUBLESHOOTING	101
Introduction	102
Troubleshooting Chart.....	103
Diagnostic Codes	108
Compressor Diagnostic Codes	109
WARRANTY	113
.....	114
.....	115
.....	116
Revision History	117



Foreword

Information

The contents of this manual are considered to be proprietary and confidential to doosan infracore portable power (herein referred to as “portable power”), and should not be reproduced without the prior written permission of portable power.

Nothing contained in this document is intended to extend any promise, warranty or representation, expressed or implied, regarding the portable power products described herein. Any such warranties or other terms and conditions of sale of products shall be in accordance with the standard terms and conditions of sale for such products, which are available upon request.

This manual contains instructions and technical data to cover all routine operation and scheduled maintenance tasks by operation and maintenance staff. Major overhauls are outside the scope of this manual and should be referred to an authorized portable power service department.

All components, accessories, pipes, and connectors added to the compressed air system should be:

- Of good quality, procured from a reputable manufacturer and, wherever possible, be of a type approved by portable power.
- Clearly rated for a pressure at least equal to the compressor safety valve setting.
- Compatible with the compressor oil.
- Accompanied with instructions for safe installation, operation, and maintenance.

Details of approved equipment are available from the portable power service departments. The use of repair parts other than those included within the approved parts list may create hazardous conditions over which portable power has no control. Therefore, portable power cannot be held responsible for equipment in which non-approved repair parts are installed.

Portable power reserves the right to make changes and improvements to products without notice and without incurring any obligation to make such changes or add such improvements to products sold previously.

The intended uses of this compressor are outlined below and examples of unapproved usage are also given. However, portable power cannot anticipate every application or work situation that may arise. **If in doubt, consult supervision.**

This compressor has been designed and supplied for above ground operation to be used for compression of normal ambient air containing no additional gases, vapors, or particles within the ambient temperature range specified in the general data section of this manual.

This compressor should not be used:

- For direct or indirect human consumption of the compressed air.
- Outside the ambient temperature range specified in the general data section of this manual.
- When an actual or foreseeable risk of hazardous levels of flammable gases or vapors exists.
- With other than portable power approved components.
- With guards, controls, or switches missing or disabled.
- For storage or transportation of materials inside or on the enclosure.

Portable power accepts no responsibility for errors in translation of this manual from the original english version.

You, as the customer, are expected to provide certain service and maintenance items. Your portable power dealer will provide all other more detailed service and maintenance items on a special preventive maintenance schedule for each compressor. It is very important that the minimum service and maintenance requirements explained in this manual be performed at the required intervals. Exceeding these intervals may reduce the reliability of the compressor.

The purpose of this manual is to train the operator with functions, operation, and basic service and maintenance requirements of the compressor. During the preparation of this manual, every effort was made to ensure the accuracy and adequacy of the contents.

Your portable power dealer will assist with setup and initial startup of the compressor and will also provide brief operating and service instructions. Before starting the compressor, this manual and instructions should be carefully read to obtain a thorough knowledge of the duties to be performed. Please take pride in the compressor, keep it clean and in good mechanical condition.

To enable proper maintenance records, portable power provides a noise emission control maintenance log in the noise emission section of this manual. The noise emission section contains a recommended maintenance schedule and provides space in the log for the technician to note what service and maintenance was done, by whom, where, and when.



Drawbar Instructions

Instruction Kit For Drawbar

To convert from shipping position to towing position

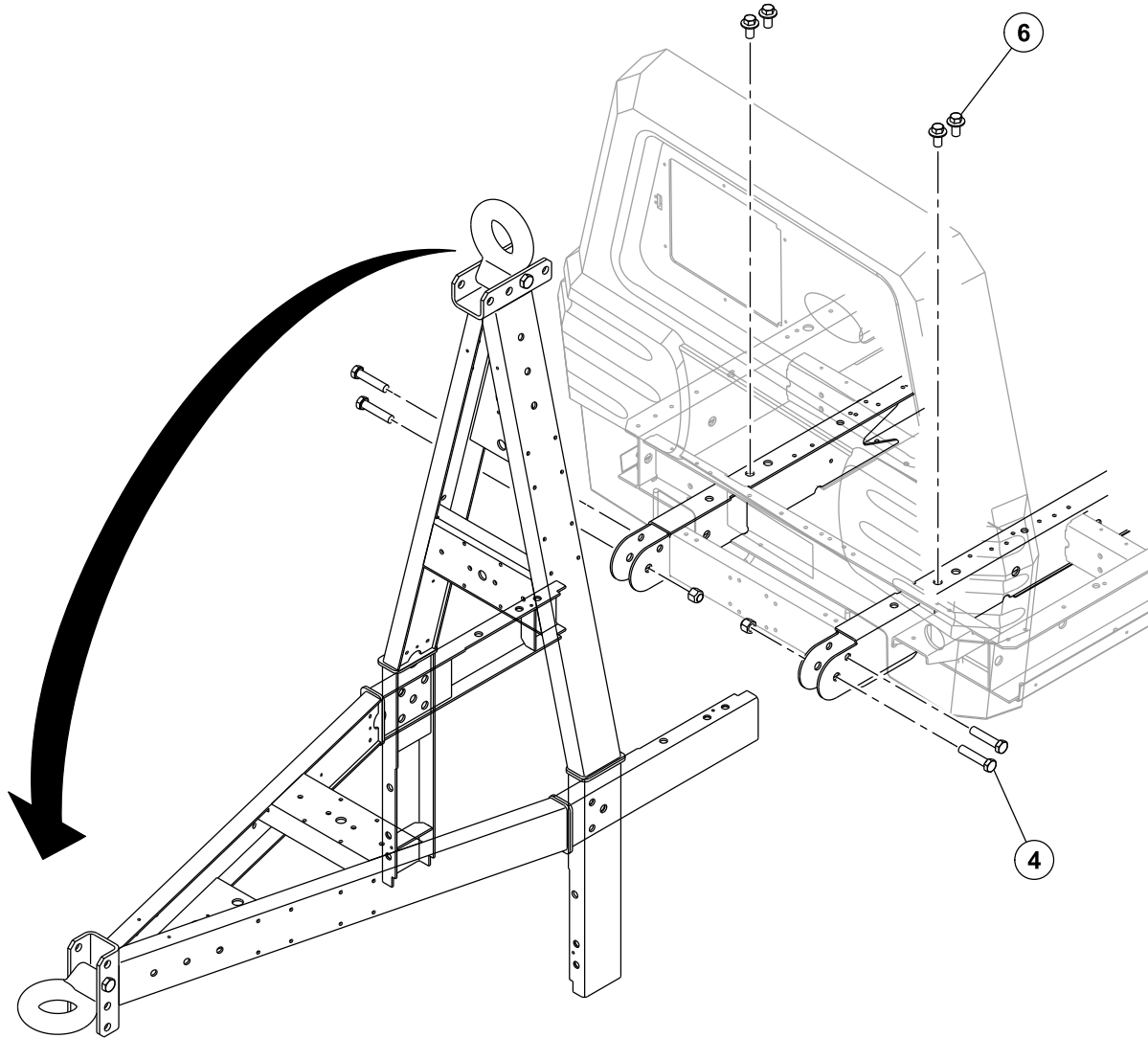

FIGURE 1: DRAWBAR POSITION

The following tools are required:

- 1/2" drive ratchet
- 1/2" drive torque wrench
- 15mm socket to fit torque wrench
- 5-inch extension for torque wrench

Hardware included:

- (4) 12mm bolts with pre-applied thread lock.

NOTE**DO NOT USE IMPACT OR AIR GUN**

1. Remove hardware box from compressor toolbox.
2. Open box and remove the bag containing hardware, safety chains, and assembly instructions.
3. Using the jack, raise the front of the unit so the drawbar legs are approximately 1-inch above the ground.
4. Remove the temporary retaining bolts from both sides of the frame at the drawbar connection and discard (see figure 1).
5. Carefully lower the drawbar to the horizontal position.
6. Install the four bolts (with pre-applied thread lock) to the four points inside the enclosure and torque to **68 pounds (92.2 newton-meters)** (See Figure 1).

Relocate jack:

1. Support the drawbar at pintle eye.
2. Pull the pin out of the jack located at the front of the enclosure. Remove the jack by sliding it off the mounting tube. Relocate and install the jack to the mounting tube on the side of the drawbar.



Safety

Safety Precautions

Never operate the compressor without first observing all safety warnings and carefully reading the operation and maintenance manual shipped from the factory with this compressor.

Ensure the operator reads and understands the decals and consults the manuals before operation or performing maintenance.

Ensure all maintenance personnel are adequately trained, competent, and have read the manuals.

Ensure all protective covers are in place and the canopy/doors are closed during operation.

The specification of this compressor is such that the compressor is not suitable for use in flammable gas risk areas. If such an application is required, all local regulations, codes of practice, and site rules must be observed. To ensure the compressor can operate in a safe and reliable manner, additional equipment such as gas detection, exhaust spark arrestors, and intake (shut-off) valves may be required, dependent on local regulations or the degree of risk involved.

A weekly visual check must be made of all fasteners/fixing screws securing mechanical parts. In particular, safety-related parts such as coupling hitch, drawbar components, wheels, tires, and lifting bail should be checked for total security.

All components which are loose, damaged, or unserviceable must be rectified without delay.

Air discharged from this compressor may contain carbon monoxide or other contaminants which will cause serious injury or death. Do not breathe discharged air.

This compressor produces loud noise with the doors open or service valve vented. Extended exposure to loud noise can cause hearing loss. Always wear hearing protection when doors are open or service valve is vented.

Never inspect or service the compressor without first disconnecting battery cable(s) to prevent accidental starting.

Do not use petroleum products (solvents or fuels) under high pressure as this can penetrate the skin and result in serious illness. Wear eye protection while cleaning the compressor with compressed air to prevent debris from injuring eye(s).

Rotating fan blade can cause serious injury. Do not operate without fan guard in place.

Use care to avoid contacting hot surfaces (engine exhaust manifold and piping, air receiver, and air discharge piping, etc.).

Ether is an extremely volatile, highly flammable gas. When it is specified as a starting aid, use sparingly. Do not use ether if the engine has glow plugs or inlet heater starting aids. Engine damage will result.

Never operate the compressor with guards, covers, or screens removed. Keep hands, hair, clothing, tools, blow gun tips, etc. Well away from moving parts.

Compressed Air

Compressed air can be dangerous if incorrectly handled. Prior to performing maintenance or service on the compressor, ensure all pressure is vented from the system and the compressor cannot be started accidentally.

Ensure the compressor is operating at the rated pressure and the rated pressure is known to all relevant personnel.

All air pressure equipment installed in, or connected to, the compressor must have safe working pressure ratings of at least the compressor safety valve setting.

If more than one compressor is connected to one common downstream plant, effective check valves and isolation valves must be fitted and controlled by work procedures, to ensure one compressor cannot accidentally be pressurized or over pressurized by another.

Compressed air must not be used for a direct feed to any form of breathing apparatus or mask.

Compressed air can cause serious injury or death. Relieve pressure before removing filler plugs/caps, fittings, or covers.

Air pressure can remain trapped in air supply line which can result in serious injury or death.

Always carefully vent air supply line at tool or vent valve before performing any service or maintenance.

Discharged air contains a very small percentage of compressor lubricating oil and care should be taken to ensure downstream equipment is compatible.

If discharged air is to be ultimately released into a confined space, adequate ventilation must be provided.

When using compressed air, always use appropriate personal protective equipment.

All pressure containing parts, especially flexible hoses and their couplings, must be regularly inspected, be free from defects, and be replaced according to the manual instructions.

Avoid bodily contact with compressed air.

The safety valve located in the separator tank must be checked periodically for correct operation.

Whenever the compressor is stopped, air will flow back into the compressor from downstream devices or systems unless the service valve is closed. Install a check valve at the compressor service valve to prevent reverse flow in the event of an unexpected shutdown when the service valve is open.

Disconnected air hoses whip and can cause serious injury or death. Always attach a safety flow restriction to each hose at the source of supply or branch line in accordance with OSHA Regulation 29 CFR Section 1926.302(b).

Never allow the compressor to sit stopped with pressure in the separator tank or piping.

Exhaust System

Hot engine exhaust gas and hot exhaust system surfaces are produced during and after compressor operation. Avoid contact with exhaust gas and hot exhaust system surfaces. Keep flammable and combustible materials away. Do not operate compressor on, under, or near flammable or combustible materials.

The potential for higher temperatures is present when the exhaust aftertreatment system undergoes regeneration. Refer to engine manual for further safety instructions and information on the exhaust aftertreatment system and controls.

Materials

The following substances may be produced during the operation of this compressor:

- brake lining dust
- engine exhaust fumes



Avoid inhalation of material substances.

Ensure that adequate ventilation of the cooling system and exhaust gases is maintained at all times.

The following substances are used in the manufacture of this compressor and may be hazardous to health if used incorrectly:

- Antifreeze
- Compressor Oil
- Engine Oil
- Preservative Grease, Lubricating Grease
- Rust Preventative
- Diesel Fuel
- Battery Electrolyte

 **WARNING****Avoid Ingestion, Skin Contact, And Inhalation Of Fumes.**

Should compressor oil come into contact with the eyes, irrigate with water for at least 5 minutes.

Should compressor oil come into contact with the skin, wash off immediately. Consult a physician if large amounts of compressor oil are ingested or if compressor oil is inhaled. Never give fluids or induce vomiting if the patient is unconscious or having convulsions.

Safety data sheets for compressor and engine oils should be obtained from the oil supplier.

Do not start or operate this compressor in a confined area. Avoid breathing exhaust fumes when working on or near the compressor.

This compressor may include such materials as oil, diesel fuel, antifreeze, brake fluid, oil/air filters, and batteries which may require proper disposal when performing maintenance or service tasks. Contact local authorities for proper disposal of these materials.

Battery

A battery contains sulfuric acid and can produce gases which are corrosive and potentially explosive. Avoid contact with skin, eyes, and clothing. In case of contact, flush area immediately with water.

 **CAUTION****Do Not Attempt To Jump Start A Frozen Battery Since This May Cause It To Explode.**

Exercise extreme caution when using an external method to jump start a unit. Verify the electrical systems on the weak battery system and the external jump system are the same voltage type system, 12VDC Or 24VDC. Connect the positive (+) terminal of the external system to the positive (+) terminal on the weak system. Connect the negative (-) terminal of the external system to the negative (-) terminal of the weak system. Always disconnect the two systems in reverse order.

Coolant System

Hot engine coolant and steam can cause injury. Ensure the reservoir cap is removed with due care and attention.

Do not remove reservoir cap while radiator is hot. Allow radiator to cool before removing reservoir cap.

WARNING

Hot engine coolant and steam can cause injury. When adding coolant or antifreeze solution to the engine radiator, stop the engine and allow radiator to cool prior to releasing the reservoir cap. Using a cloth to protect the hand, slowly release the reservoir cap, absorbing any released fluid with the cloth. Do not remove the reservoir cap until all excess fluid is released and the engine cooling system fully depressurized.

WARNING

Follow the instructions provided by the antifreeze supplier when adding or draining the antifreeze solution. It is advisable to wear personal protective equipment to prevent skin and eye contact with the antifreeze solution.

Transport

When loading or transporting the compressor, ensure the specified lifting and tie down points are used.

When loading or transporting the compressor, ensure the towing vehicle, its size, weight, towing hitch, and electrical supply are all suitable to provide safe and stable towing at speeds either, up to the legal maximum for the country in which it is being towed, or as specified for the compressor model if lower than the legal maximum. Do not exceed gross vehicle weight rating.

Before towing the compressor, ensure:

- The tires and towing hitch are in a serviceable condition and tires are properly inflated.
- The canopy is secure.
- All ancillary equipment is stored in a safe and secure manner.
- The brakes and lights are functioning correctly and meet necessary road traffic requirements.
- Breakaway cables/safety chains are connected to the towing vehicle.

The compressor must be towed in a level attitude in order to maintain correct handling, braking, and lighting functions. This can be achieved by correct selection and adjustment of the vehicle towing hitch and, on variable height running gear, adjustment of the drawbar.

1. Ensure wheels, tires, and drawbar connectors are in safe operating condition and drawbar is properly connected before towing.
2. When parking, always use the handbrake and, if necessary, suitable wheel chocks.

Safety Chains/Breakaway Cable And Their Adjustment (Where Fitted).

Ensure breakaway cable is securely coupled to the towed compressor and also to a substantial anchorage point on the towing vehicle.

Ensure cable length is as short as possible, while still allowing enough slackness for the towed compressor to articulate without the brake being applied.

Attach safety chains to the towing vehicle at substantial anchorage points of suitable strength.

Ensure effective chain length is as short as possible while still allowing normal articulation of the towed compressor and proper operation of the breakaway cable.

Decals

Free Safety Decals

To promote communication of Safety Warnings on products manufactured by the Portable Power Division in Statesville, N.C., Safety Decals are available FREE of charge. Safety Decals are identified by the decal heading: DANGER, WARNING, CAUTION, NOTICE.

Decal part numbers are located in the lower right hand corner of each decal and are also listed in the compressor Parts Manual. Submit orders for Safety Decals to the Statesville Parts Service Dept. The no charge order should contain only Safety Decals.

Help promote product safety! Ensure decals are present on the compressor. Replace decals that are not readable.

Decals on the following pages contain examples of decals available for this equipment.

Decals are located on the compressor to point out potential safety hazards. Read and follow these instructions. If you do not understand these instructions, inform your supervisor.



(Red Background)

Indicates the presence of a hazard which **WILL** cause serious injury, death, or property damage, if ignored.



(Orange Background)

Indicates the presence of a hazard which **CAN** cause serious injury, death, or property damage, if ignored.



(Yellow Background)

Indicates the presence of a hazard which **WILL** or **CAN** cause injury or property damage, if ignored.



(Blue Background)

Indicates important set-up, operating, or maintenance information.



CAUTION

DO NOT WELD.
ELECTRONIC DAMAGE WILL OCCUR.

This machine is equipped with electronic components.

46663642 REV. A



WARNING

Combustible gas.
Can cause serious burns, blindness or death.



Keep sparks and open flames away from batteries.

54568753 REV. C









WARNING

Rotating fan blade.
Can cause serious injury.



Do not operate without guard in place.

54568779 REV. C

 <p>DANGER</p>  <p>Discharged air can contain carbon monoxide or other contaminants. Will cause serious injury or death. Do not breathe this air.</p>	 <p>WARNING</p> <p>Trapped air pressure. Can cause serious injury or death.</p>  <p>Close service valve and operate tool to vent trapped air before performing any service.</p>	 <p>WARNING</p> <p>Disconnected air hoses whip. Can cause serious injury or death.</p>  <p>When using air tools attach safety device (OSHA Valve) at source of air supply for each tool.</p>
--	--	--

54629902 REV. C



WARNING

High pressure air.
Can cause serious injury or death.



Relieve pressure before removing filler plugs/caps, fittings or covers.

54568795 REV. C



WARNING

Hot Surfaces.



Serious injury or death can occur.

Do not touch components.
Allow machine to cool before touching.

22334916 REV. B



WARNING

Improper operation of this equipment.
Can cause serious injury or death.

Read Operator's Manual supplied with this machine before operation or servicing.

Modification or alteration of this machine.
Can cause serious injury or death.

Do not alter or modify this machine without the express written consent of the manufacturer.

54568787 REV. C



ULTRA LOW SULFUR DIESEL FUEL ONLY
(15PPM SULFUR MAXIMUM)

46556990 REV. B





CAUTION

DO NOT USE ETHER.
ENGINE DAMAGE WILL OCCUR.

This engine is equipped with an electric heater starting aid.

54454756 REV. E

WARNING

Hot pressurized fluid.
Can cause serious burns.



Do not open radiator while hot.

54568781 REV. C

22383319 REV. A

OVER-FILLED

CHECK BEFORE STARTING

OIL LEVEL OK

ADD



Doosan Infracore
Portable Power

COMPRESSOR NOISE EMISSION CONTROL INFORMATION

THIS COMPRESSOR CONFORMS TO U.S. E.P.A. REGULATIONS FOR NOISE EMISSIONS APPLICABLE TO PORTABLE AIR COMPRESSORS. THE FOLLOWING ACTS OR THE CAUSING THEREOF BY ANY PERSON ARE PROHIBITED BY THE NOISE CONTROL ACT OF 1972:

(A) THE REMOVAL OR RENDERING INOPERATIVE, OTHER THAN FOR THE PURPOSE OF MAINTENANCE, REPAIR, OR REPLACEMENT, OF ANY NOISE CONTROL DEVICE OR ELEMENT OF DESIGN INCORPORATED INTO THIS COMPRESSOR IN COMPLIANCE WITH THE NOISE CONTROL ACT;

(B) THE USE OF THIS COMPRESSOR AFTER SUCH DEVICE OR ELEMENT OF DESIGN HAS BEEN REMOVED OR RENDERED INOPERATIVE.

TO ASCERTAIN POINT OF ORIGIN, DATE OF MANUFACTURE, AND RELATED INFORMATION VERIFYING COMPLIANCE TO E.P.A. REGULATIONS FOR NOISE EMISSIONS, PLEASE CONTACT YOUR NEAREST DOOSAN INFRACORE PORTABLE POWER DEALER AND REFERENCE YOUR COMPRESSOR SERIAL NUMBER.

36514602 REV. C



Noise Emission

Noise Emission

This Section Pertains Only To Compressors Distributed Within The United States.



Tampering With Noise Control System Prohibited.

Federal Law Prohibits the following Acts or the Causing Thereof:

(1) the removal or rendering inoperative by any persons, other than for purposes of maintenance, repair, or replacement, of any device or element of design incorporated into any new compressor for the purpose of noise control prior to its sale or delivery to the ultimate purchaser or while it is in use; or (2) the use of the compressor after such device or element of design has been removed or rendered inoperative by any person.

Among those acts included in the prohibition against tampering are these:

1. Removal or rendering inoperative any of the following:
 - A. The Engine Exhaust System or Parts thereof
 - B. The Air Intake System or Parts thereof
 - C. Enclosure or Parts thereof
2. Removal of any of the following:
 - A. Fan Shroud
 - B. Vibration Mounts
 - C. Sound Absorption Material
3. Operation of the Compressor with any of the Enclosure Doors Open.

Compressor Noise Emission Control Information

A. Removal or rendering inoperative, other than for the purpose of maintenance, repair, or replacement of any noise control device or element of design incorporated into this Compressor in compliance with the Noise Control Act.

B. The use of this Compressor after such device or element of design has been removed or rendered inoperative.

Note: The Above Information Applies Only To Compressors That Are Built In Compliance With The U.S. Environmental Protection Agency.

Portable power reserves the right to make changes or add improvements without notice and without incurring any obligation to make such changes or add such improvements to products sold previously.

The purchaser is urged to include the above provisions in any agreement for any resale of this Compressor.

Maintenance Log

COMPRESSOR MODEL:
SERIAL NO:
USER UNIT NO:

UNIT IDENTIFICATION	DEALER / DISTRIBUTOR INFORMATION
Engine Make & Model:	Purchased From:
Serial No:	
Purchaser or Owner:	
Address:	Date Purchased:

The Noise Control Act Of 1972 (86 Stat. 1234) Prohibits Tampering with the Noise Control System of any Compressor Manufactured and Sold Under The Above Regulations, Specifically The Following Acts or the Causing Thereof:

(1) The Removal Or Rendering Inoperative by any persons, other than for Purposes Of Maintenance, Repair, or Replacement, of any Device or Element of Design Incorporated into new Compressor for the purpose of Noise Control prior to its Sale or Delivery to the Ultimate Purchaser or while it is in use; or (2) the use of the Compressor after such Device or Element of Design has been removed or rendered inoperative by any person.

Noise Emission Warranty

The Manufacturer Warrants to the Ultimate Purchaser and each Subsequent Purchaser that this Air Compressor was Designed, Built and Equipped to conform at the time of Sale to the First Retail Purchaser, with all applicable U.S. EPA Noise Control Regulations.

This Warranty is not Limited to any Particular Part, Component, or System of the Air Compressor. Defects in the Design, Assembly or in any Part, Component, or System of the Compressor which, at the time of Sale to the First Retail Purchaser, caused Noise Emissions to Exceed Federal Standards are covered by this Warranty For the Life of Air Compressor.(40 CFR 204.58-1)

Introduction

The Compressor for which this Maintenance Log is provided conforms To U.S. EPA Regulations for Noise Emissions, applicable to Portable Air Compressors.

The purpose of this book is to provide (1) The Maintenance Performance Schedule for all Required Noise Emission Controls and (2) Space so that the Purchaser or Owner can record what Maintenance was done, by whom, where and when. The Maintenance Schedule and Detailed Instructions on the Maintenance Items are given on the following page.

Maintenance Schedule

PERIOD	DESCRIPTION
As Detected	<p>COMPRESSED AIR LEAKS</p> <p>Correct all compressed air leaks during the first shutdown period after discovery. If severe enough to cause serious noise problems and efficiency loss, shut down immediately and correct the leak(s).</p>
As Detected	<p>SAFETY AND CONTROL SYSTEMS</p> <p>Repair or replace all safety and control systems or circuits as malfunction occurs. No compressor should be operated with either system bypassed, disabled, or nonfunctional.</p>
Daily	<p>ACOUSTIC MATERIALS</p> <p>In daily inspections, observe these materials. Maintain all acoustic material as nearly as possible in its original condition. Repair or replace all sections that have: 1) sustained damage, 2) have partially separated from panels to which they were attached, 3) are missing, or have otherwise deteriorated due to severe operating or storage conditions.</p>
100 HOURS	<p>FASTENERS</p> <p>All fasteners such as hinges, nuts, bolts, clamps, screws, rivets, and latches should be inspected for looseness after each 100 hours of operation. They should be retightened, repaired, or if missing, replaced immediately to prevent subsequent damage and noise emission increase.</p>
100 HOURS	<p>ENCLOSURE PANELS</p> <p>Enclosure panels should be inspected at 100 hour operational intervals. All panels that are warped, punctured, torn, or otherwise deformed, such that their noise containment function is reduced, should be repaired or replaced before the next operation interval. Doors, access panels, and hatch closures especially, should be checked and adjusted at this time to ensure continuous seating between gasket or acoustic material and the mating frame.</p>

PERIOD	DESCRIPTION
100 HOURS	<p>AIR INTAKE AND ENGINE EXHAUST</p> <p>Engine and compressor air intake and engine exhaust systems should be inspected after each 100 hours of operation for loose, damaged, or deteriorated components. Repairs or replacements should be made before the next period of use.</p>
250 HOURS	<p>COOLING SYSTEMS</p> <p>All components of the cooling system for engine water and compressor oil should be inspected every 250 hours of use. Any discrepancies found should be corrected before placing the compressor back in operation. Unrestricted airflow over the radiator and oil cooler must be maintained at all times during operation.</p>
250 HOURS	<p>ISOLATION MOUNTS</p> <p>Engine/Airend isolation mounts should be inspected after each 250 hours of operation. Those mounts with cracks or splits in the molded rubber or with bent or broken bolts due to operation or storage in severe environments should be replaced with equivalent parts.</p>
See Operator Manual	<p>ENGINE OPERATION</p> <p>Inspect and maintain engine condition and operation as recommended in the manuals supplied by the engine manufacturer.</p>
See Operator Manual	<p>FUELS AND LUBRICANTS</p> <p>Use only the types and grades of fuels and lubricants recommended in the Operator and Maintenance Manual and Engine Manual.</p>



General Data

General Data Information

UNIT MODEL	C185WDO-T4F
Rated Flow CFM (litres/sec)	185 (87 l/s)
Engine Speed - RPM (Full Load)	2600
Engine Speed - RPM (No Load)	1700
COMPRESSOR	
Rated Operating Pressure - psi (kPa)	100 (689)
Safety Valve Setting - psi (kPa)	200 (1380)
ENGINE (Diesel)	
Manufacturer	DOOSAN
Model	DL01
Electrical System	12VDC
FLUID CAPACITIES	
Compressor Lubricant - gallon (litres)	3.5 (13.3 liters)
Engine Cooling System - gallon (litres)	2.4 (9.0 liters)
Engine Crankcase Lubricant - gallon (litres)	1.7 (6.4 liters)
Fuel Tank - gallon (litres)	34.5 (130.6 liters)
RUNNING GEAR	
Tire Size	ST175/80/D13
Inflation Pressure (Cold) psi	50
Towing Speed (Maximum) mph (km/hr)	65 mph (105)
UNIT MEASUREMENTS & WEIGHTS	
Overall Length - feet (meters)	11.5 (3.5)
Overall Height - feet (meters)	5.2 (1.56)
Overall Width - feet (meters)	5.5 (1.67)
Track Width - feet (meters)	4.9 (1.49)
Weight (with fuel) - lbs (kg)	2408 lbs. (1092 kg)
Weight (less fuel) - lbs (kg)	2153 lbs. (976 kg)

Expendable Service Parts

Description	Part Number
Compressor Oil Filter Element	46680086
Compressor Oil Separator Element	46652735
Air Cleaner Element (Compressor) Primary	46707046
Air Cleaner Element (Engine) Primary	46707046
Air Cleaner Element (Compressor) Secondary-Optional	46707047
Air Cleaner Element (Engine) Secondary-Optional	46707047
Engine Oil Filter Element	46668934
Pre-Fuel Filter	36845493
Final Fuel Filter w/WIF Sensor	46664395
PRO-TEC® Compressor Fluid (1 gal)	36899698
Tier 4® Engine Fluid (1 gal)	46557017

 **WARNING**

Modification or alteration of this machine. Can result in severe injury or death. Do not modify or alter without the express written consent of Doosan Infracore Portable Power.



Operating Instructions

Control Panel

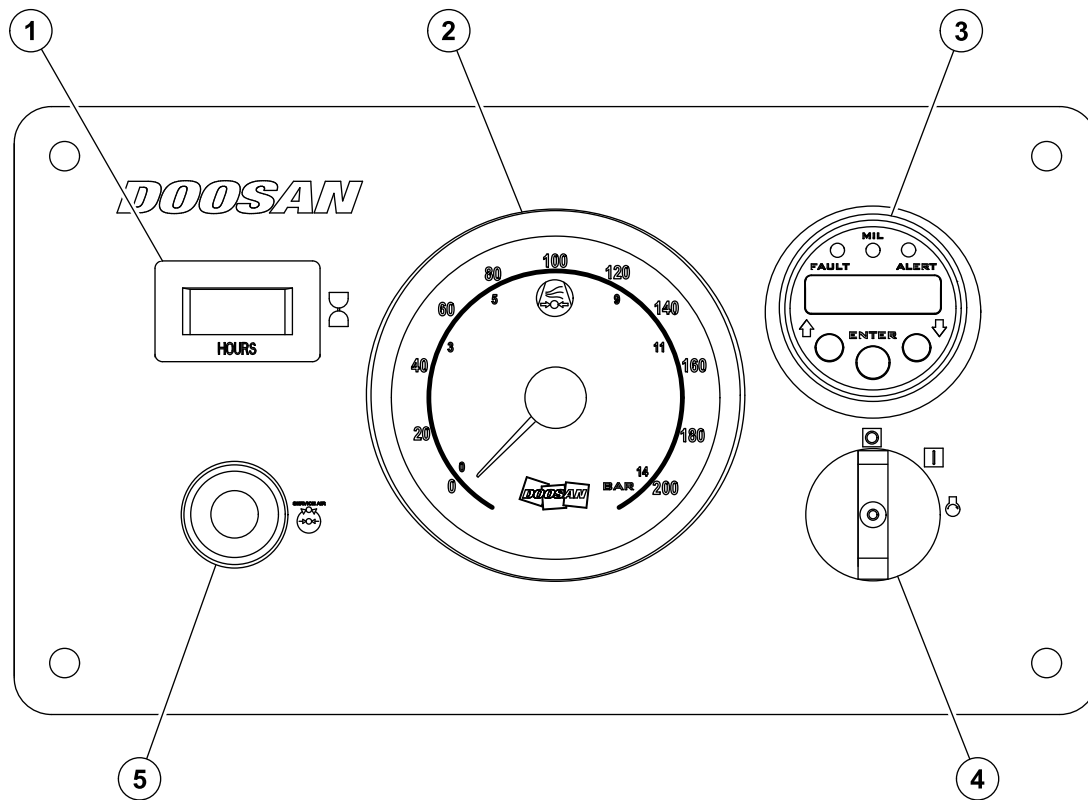

Control Panel Gauges

1. **Hour Meter:**
Display machine hours
2. **Air Pressure Gauge:**
Indicates pressure in the Separator Tank.
3. **Micro-Port Display:**
Displays compressor, engine operating parameters, and diagnostic codes.
4. **4-Position Start Switch:**
Rotate to "ON" position and wait for the Micro-Port message "WAIT TO START" to go off and show engine RPM prior to starting. Rotate to "OFF" to stop engine.
5. **Service Air Push Button:**
Push to load the machine after warm-up of engine for 3 minutes.

Quick View Screens

Engine and Compressor Parameters

The Quick View Screens allow for easy viewing of up to 11 commonly used parameters by pressing the UP and DOWN buttons. Pressing the UP and DOWN buttons continuously loops through the Quick View Screens (i.e., when the last screen is reached pressing the DOWN button displays the first screen and vice versa). See Figure 1.

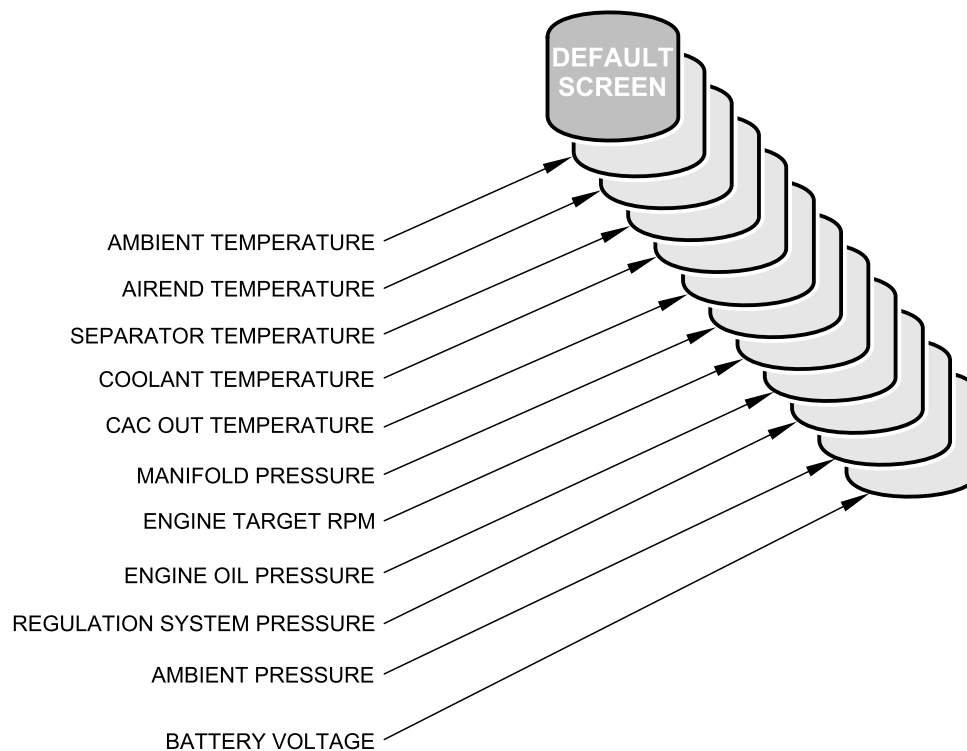

FIGURE 1

Note 1: Only the Parameters that are available from the Engine or Compressor will be Displayed.

Note 2: Unit times out after 3 minutes of inactivity and returns to the Default Screen.

Note 3: Pressing the Enter button while viewing a Quick View screen will return to the Default Screen.

Default Screen

The Default Screen will Display the Engine RPM unless the machine is configured with the Fuel Level option. With the Fuel Level option installed, The Default Screen will be Fuel level and the first screen of the Quick View will be Engine RPM.

Fault and Alert

If a Fault occurs, the Display unit will Display The SPN, FMI, OC, and description for Engine Fault or the CPR Code and description for Compressor Error. An Engine Fault will be Displayed only when the Engine is shutdown. The Fault has to be acknowledged by the user by pressing the Enter button. The unit does not time out in the Fault display. After 60 seconds, If the fault is still Active, The Fault display will appear again on the screen and will remain until acknowledged by the User. This will continue to occur as long as the Fault is Active. See Figure 2

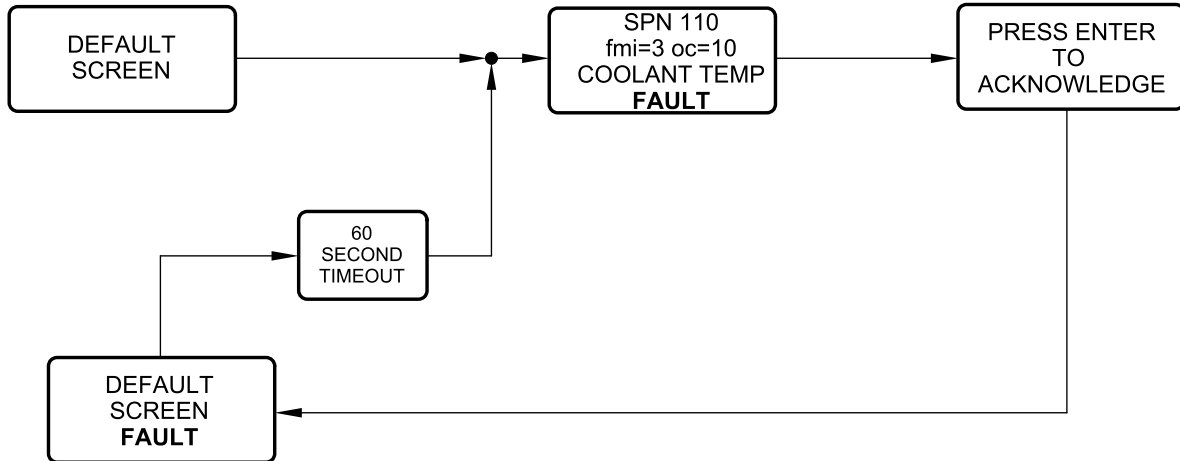

FIGURE 2

Fault and Alert (Continued)

When present, an Alert with the number of Alert conditions will popup on the screen, the User will press the UP or DOWN button to display the Alert, or press the Enter button to acknowledge an Alert has occurred. If there are Multiple Alerts, pressing the DOWN button will scroll through the various Alerts. All Faults and Alerts will be Displayed until the Engine shuts down and then the most severe Fault will be Displayed as a Fault. Pressing the ENTER button after the Alert has been Displayed, acknowledges the message and the Display unit returns to the Default screen of Engine hours. See Figure 3.

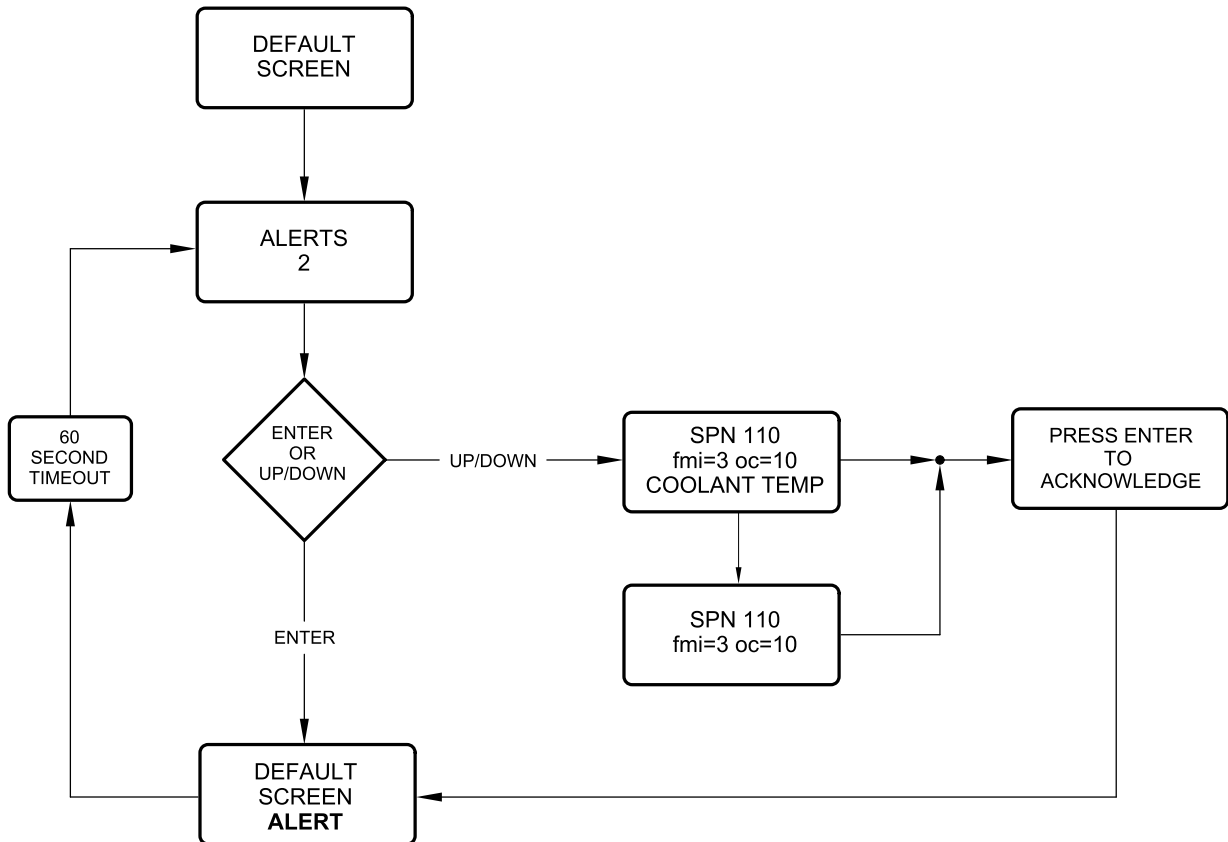

FIGURE 3

Service Interval Setup

Service will popup on the screen after one of the two hour service channels has decremented to 5 hours. The user will press the UP or DOWN button to display the service channels or press the ENTER button to acknowledge a service has occurred. Pressing the ENTER button after the service channels have been displayed, acknowledges The message and the display unit returns to the Default Screen. If service is between 5 and 0 hours or it remains at 0 hours, the SERVICE DUE Display will appear every hour. To disable, the user can reset the hours to the OFF position by decreasing the value to OFF. See Figure 4.

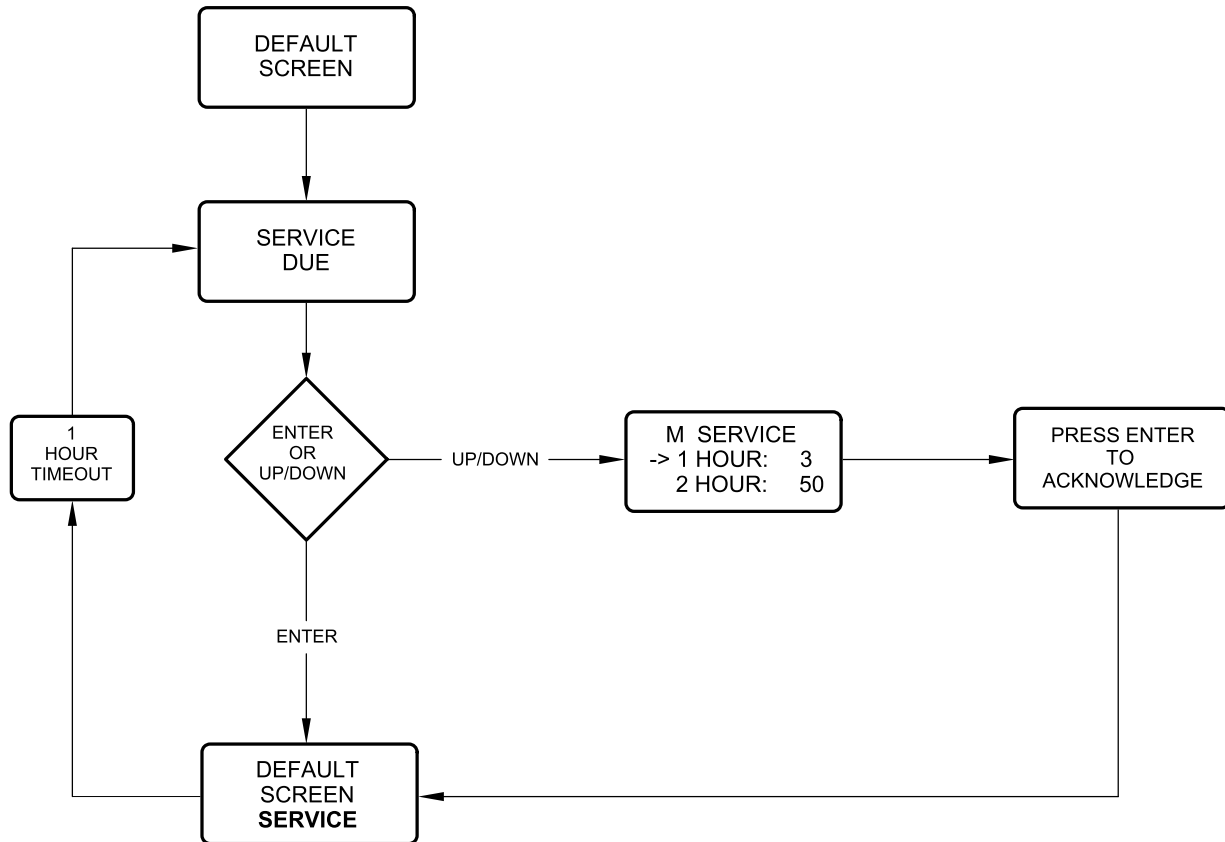

FIGURE 4

Service Interval Setup (Continued)

The service intervals can be changed by pressing the ENTER button while on the Default Screen that Displays The Engine Hours. Using the UP or DOWN buttons To highlight the desired interval and press the ENTER button to select. Use the UP and DOWN buttons to Increase or Decrease the number of hours. Hours will decrement with every hour on the engine. Use the DOWN button to highlight the Main Screen Menu Item and press the ENTER button to return to the Default Screen of Engine Hours. See Figure 5.

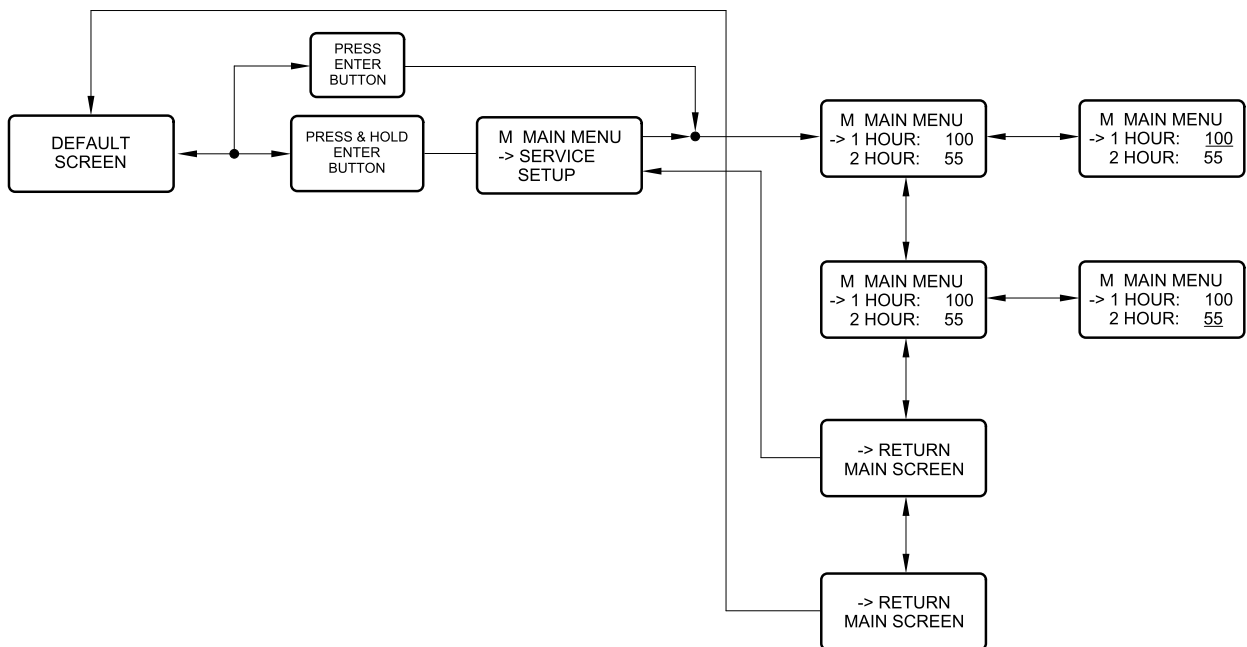

FIGURE 5

Languages and Units

The Display is User configured to Display in English, Spanish, Or French languages and in either English or Metric units. The Language and Display units can be changed by accessing the Setup Menu. to access the Setup Menu, press and hold the ENTER button while the Default Screen of Engine Hours is Displayed until the Main Menu appears. Scroll to the Setup Option using the DOWN button then press the ENTER button. Use the DOWN or UP buttons to highlight the chosen Unit and PRESS the ENTER button to select. To Return to the Default Screen of Engine Hours, use the DOWN button to highlight the Main Screen Menu item and press the ENTER button. See Figure 6.

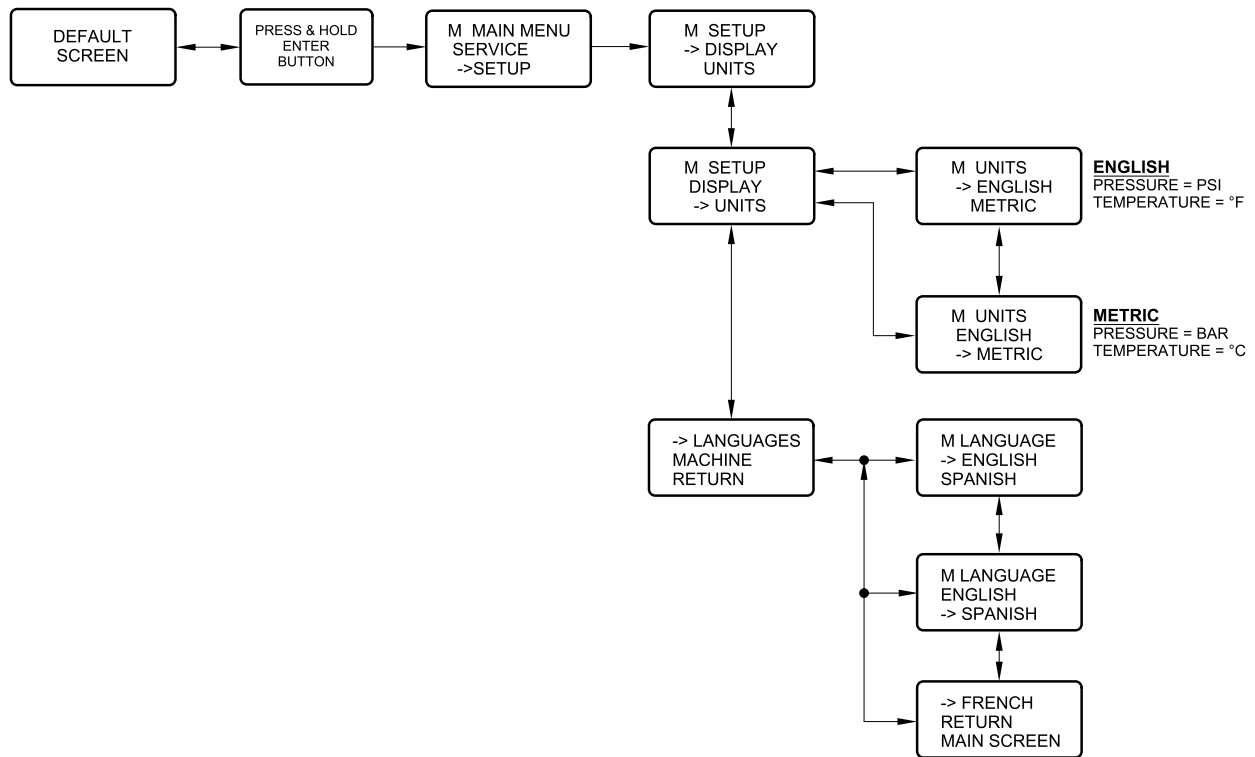

FIGURE 6

Display Setup

The Display Menu functions give users the ability to configure the LCD. Options for configuring the Display include Intensity, Contrast, and Viewing Mode. To access the Display Menu, press and hold the ENTER button while the Default Screen of Engine Hours is Displayed until the Main Menu appears. Scroll to the Setup Option using the DOWN button and press the ENTER button. Scroll to the Display Option using the DOWN button and press The ENTER button. Use the DOWN or UP buttons to highlight and the ENTER button to select the desired Display setting. To Return to the Default Screen of Engine Hours, use the DOWN button to highlight the Main Screen Menu Item and press the ENTER Button. See Figure 7.

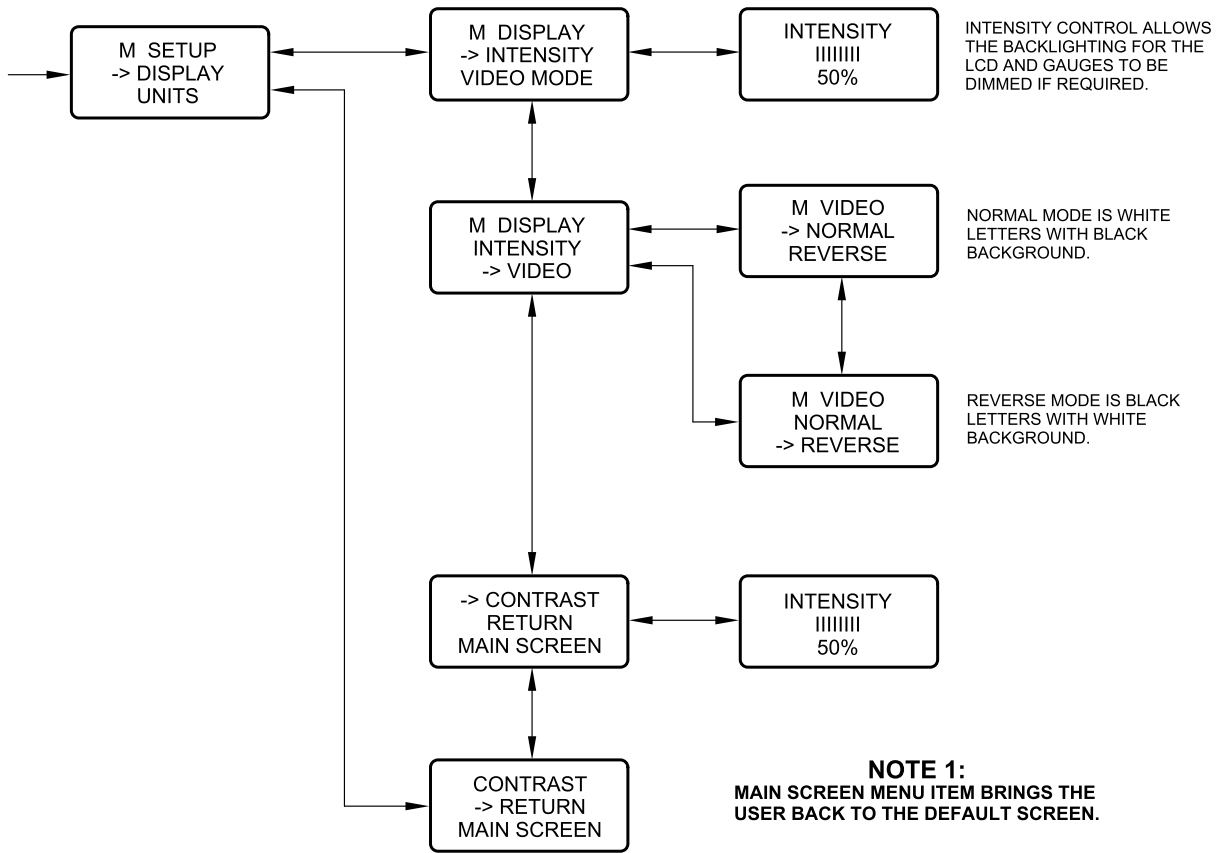

FIGURE 7

WAIT TO START

When the Main Power Button is pressed the display will initialize and then the wait to start message will be displayed. Wait to Start offers a chance to check for Faults/Alerts prior to crank.

Display Compressor and Display Software Information

Change Compressor ID

The Compressor ID is a unique 3 digit code that identifies the model of machine in the software. The Compressor ID is Set at the Factory and should NOT be Changed. The Compressor ID can be changed by accessing the Setup Menu. To access the Setup Menu, press and hold the ENTER button while the Default Screen is displayed until the Main Menu appears. Scroll to the Setup option using the DOWN button then press the ENTER button. Use the DOWN or UP buttons to highlight and the ENTER button to select the desired preference. To return to the default screen, use the DOWN button to highlight the Main Screen menu item and press the ENTER button. See Figure 8.

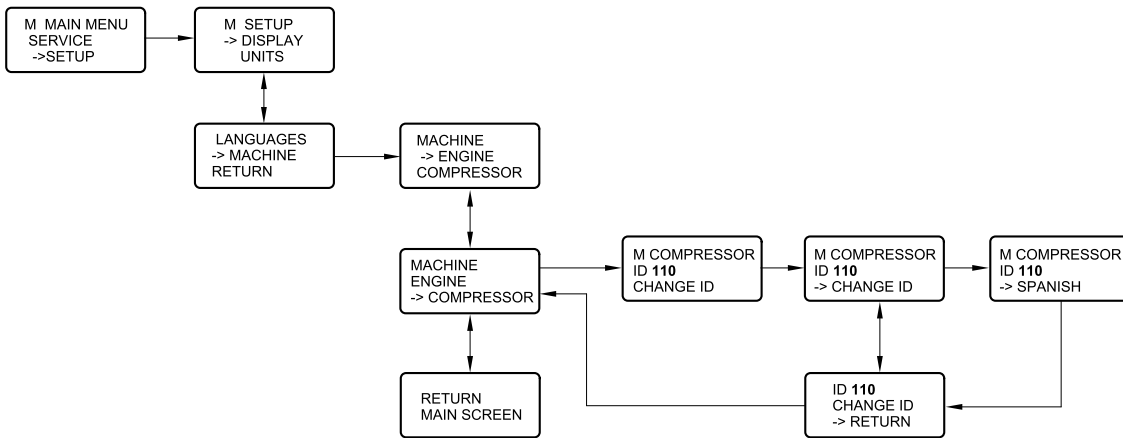

FIGURE 8

Display Compressor and Display Software Information

The Compressor and Display software information can be Displayed by accessing the Misc. Menu. To access the Misc. Menu, Press and hold the ENTER button while the Default Screen is Displayed until the Main Menu appears. Scroll to the Misc. Option using the DOWN button then press the ENTER button. Use the DOWN or UP buttons to highlight and the ENTER button to select the desired preference. To return to the Default Screen, use the DOWN button to highlight the Main Screen Menu and press the ENTER button. See Figure 9.

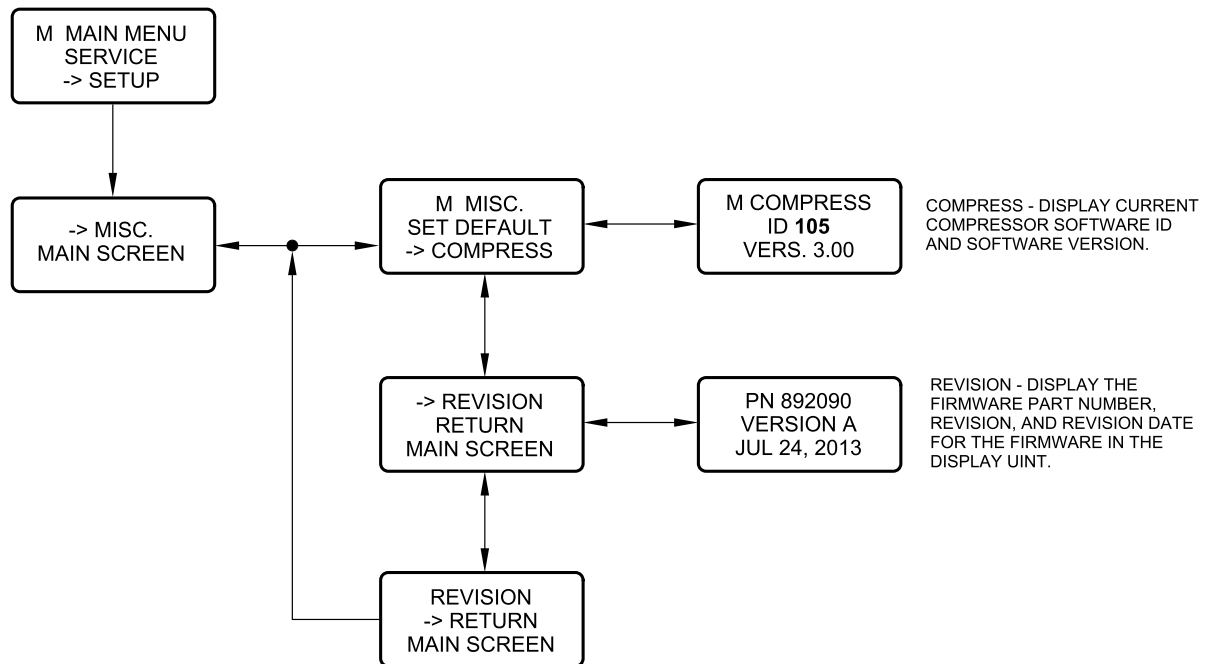

FIGURE 9

Before Towing

WARNING

Failure to follow these instructions CAN cause severe injury or death.

- Ensure tow vehicle has towing capacity for weight of this unit as stated on general data decal. Use jack to raise or lower drawbar.
- Position the tow vehicle to align its hitch with the pintle eye or coupler of the compressor.
- Engage the parking brake and chock the tires of the tow vehicle.
- Stand to the side and ensure pin is FULLY inserted (secure) in tube of jack.
- Crank jack to seat pintle eye or coupler onto hitch. Latch and lock hitch. Cross safety chain(s) under drawbar. Attach to vehicle.
- Fold jack handle down and forward. Swing up jack tube and FULLY insert pin in tube.
- Remove tire chocks.
- Test brakes, if so equipped.
- Test lights (running, stop, and turn signals).

WARNING

Always raise (or remove) jack for maximum ground clearance before towing.

Setting Up

- Position as level as possible. The design of these units permits a 15 degree sidewise limit on out-of-level operation.
- When the unit is to be operated out-of-level, it is important:
 - To keep the engine crankcase oil level near the high level mark (with the unit level).
 - To have the compressor oil level gauge show no more than mid-scale. Do not overfill either the engine crankcase or the compressor lubricating oil system.
- The side doors must be closed to maintain a cooling air path and to avoid recirculation hot air.

Towing



Failure to follow these instructions CAN cause severe injury or death.

Disconnect

- Engage tow vehicle parking brake.
- Chock tires of compressor.
- Set the vehicle parking brake. Chock wheels of unit.
- Standing to the side, remove pin from tube of jack.
- Disconnect safety chains. Crank jack to raise eye or coupler from hitch. Tow vehicle can be moved.

UTILITY PACKAGE SET-UP (No Running Gear)

This unit must be located on vehicle bed to allow access for normal servicing and maintenance.

The air going into the inlet must be relatively free of oil, dirt, soot and other debris. It must be no more than 10°F (5°C) over the ambient temperature.

Before Starting

- Open service valve(s) to ensure pressure is relieved in receiver-separator system. Close valve(s) in order to build up full air pressure and ensure proper oil circulation.
- Check battery for proper connections and condition.
- Check engine coolant level.



Do not remove reservoir cap from a hot radiator. Allow radiator to cool down before removing reservoir cap. Use extreme care when removing a reservoir cap from a liquid cooling system for the engine. The sudden release of pressure from a heated cooling system can result in a loss of coolant and possible severe personal injury.

- Check the engine oil level. Maintain per marks on dipstick.
- Check the fuel level. Add only clean ultra low sulfur diesel fuel for maximum service from the engine.
- Check the compressor lubricating fluid level between bottom and midway of the sight glass on the separator tank.

- Drain water from fuel/water separator.

 **WARNING**

This machine produces loud noise with doors open. Extended exposure to loud noise can cause hearing loss. Wear hearing protection when doors or valve (s) are open.

- Close all doors to maintain a cooling air path and to avoid recirculation of hot air. This will maximize the life of the engine and compressor and protect the hearing of surrounding personnel.
- Be sure no one is IN or ON the compressor unit.

 **WARNING**

Unrestricted air flow from a hose will result in a whipping motion of the hose which can cause severe injury or death. A safety device must be attached to the hose at the source of supply to reduce pressure in case of hose failure or other sudden pressure release. Reference: OSHA regulation 29 CFR Section 1926.302 (b).

Starting

 **CAUTION**

Do not use ether or any other starting fluid. Starting fluids can cause An explosion, fire, and severe engine damage. The engine is equipped with an electric heater starting aid.

1. Press the main power button.
2. When the wait to start message disappears, press and release green start button.
3. Engine will crank until engine starts or engine starting time limit is reached. The first light on the start button will illuminate.
4. If engine fails to start, press main power button to remove power from engine. Repeat steps 1-3.
5. When engine starts, the first two lights on the start button will illuminate.
6. Wait for engine temperature to reach 150° F (65° C). Press service air button. The third light on the start button will illuminate.

 **CAUTION**

To ensure an adequate flow of oil to the Airend, never allow the discharge pressure to fall below 50 psi.

Normal Operation

The operator may observe and monitor operating parameters using the Mini-Port and gauges. In the event the compressor controller detects a parameter outside normal operating limits, the compressor will alert and/or shutdown, and display a diagnostic code.

In the event the compressor controller detects a parameter at a dangerously high or low level, the compressor will be automatically shut down with the cause of the shutdown shown on the Mini-Port.

Operation Loaded

Assume engine has been started and is running in the unload state at idle speed. If there is air demand (pressure falls below the load point pressure), compressor will load at idle speed by opening the inlet valve. As air demand rises and falls, engine speed is controlled between idle speed and full load speed to match the required flow while maintaining load point pressure.

Operation Unloaded

If there is no air demand at idle speed (pressure rises above the unload point pressure), the compressor will unload by closing the inlet valve. The compressor then runs at idle speed unloaded with no air delivery. If air demand increases (pressure falls below the load point pressure), the compressor reloads to meet the required air demand.

Shutdown

1. Close all Service Valves.
2. Allow the engine to idle for 3 minutes to cool down.
3. Press the Red Stop Button.
4. Press the Main Power Button when use of the compressor is not needed.

Note: Until Main Power Button is pressed, the gauges can be read and the Mini-Port can be navigated using the UP, DOWN, and ENTER Buttons.

5. If the Main Power Button is not pressed within 3 minutes (if ambient temperature is above 45° F (7° C) or 15 minutes if ambient temperature is 45° F (7° C) or below of the keypad use the compressor will automatically shut off.

WARNING

Since the service valve is closed, air downstream of the valve may be trapped. A vent hole in the service valve will slowly bleed air from the hose. Do not disconnect hoses until all pressure has been vented.

NOTICE

Do NOT wire around or bypass a shutdown sensor or switch.

Pressure Regulator Adjustment Instructions

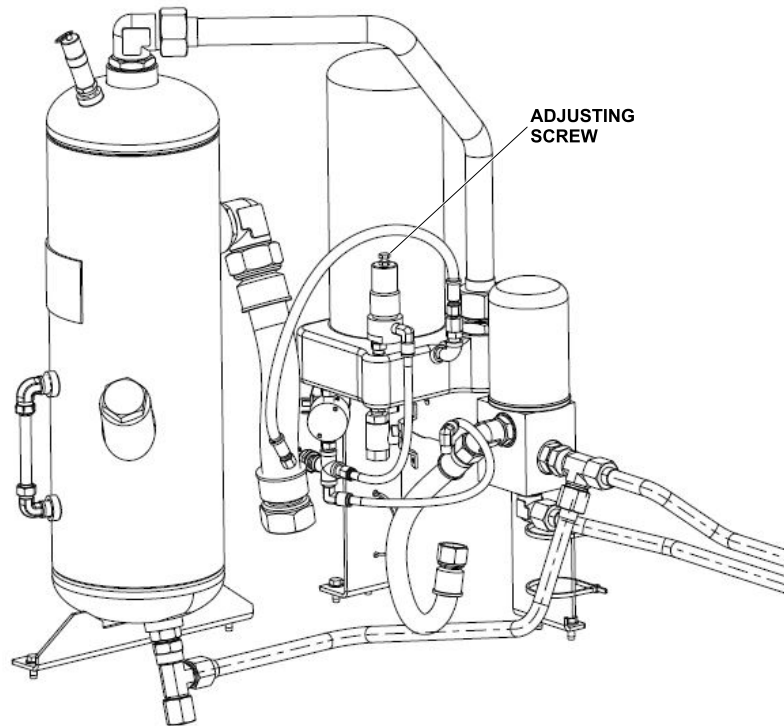

Before Starting

1. Close service valve(s).

After Starting

2. Push the service air button on the control panel. The unit should speed up, build air pressure and drop back to idle. With the unit at idle, turn the adjusting screw on the pressure regulator clockwise until the discharge pressure gauge indicates 125-130 psi. Tighten the pressure regulator jam nut.



Engine Operation

Engine Operation and Maintenance

We, Doosan Infracore, do our best to provide more convenient and safe maintenance techniques and to meet the requirements of our customers. If you have any questions or find any errors in this Operation and Maintenance Manual, please do not hesitate to contact us.

Thank you for purchasing our engine and we hope this Operation and Maintenance Section will be helpful for you.

General Information

This Operation and Maintenance Section provides the most efficient methods for engine maintenance as well as quick, efficient methods to determine the cause of engine faults to ensure that any actions taken by professionally certified maintenance technicians are done in the most efficient way possible. If maintenance is performed by unskilled technicians, or maintenance performed without the specified tools and facilities, serious bodily injury or critical faults in engine performance may occur.

Regular inspection and maintenance are required to maintain long term optimal engine conditions and best performance. In the event that a part must be replaced, only genuine Doosan parts, as defined by the parts list (Parts Manual) should be used. Doosan shall not be held liable for any critical damage or faults which may be caused by the use of unauthorized or non-factory remanufactured parts.

The maintenance methods stated in this Operation and Maintenance Section are the most efficient and safest work procedures. Some work procedures require special tools.

For questions about genuine parts and special tools, please contact us.

This Operation and Maintenance Section includes **Danger, Warning, and Caution** headings in order to reduce possible injuries and engine faults which may occur while performing maintenance. If workers do not follow the instructions, critical faults in engine performance and operation or serious bodily injury may occur. **Danger, Warning, and Caution** instructions must be followed.

Safety

This Operation & Maintenance Section divides maintenance operations such as performing engine checks, troubleshooting, or diagnosing faults into three categories, Danger, Warning, and Caution. In addition, Note is used to provide additional descriptions and information required for maintenance technicians to successfully operate our engines. The recommended repair methods and Danger, Warning, and Caution can enhance the degree of completion of engine maintenance and prevent bodily injury which may occur to workers. However, this section cannot predict all possible risks.

In the event the compressor controller detects a parameter at a dangerously high or low level, the compressor will be automatically shut down with the cause of the shutdown shown on the Mini-Port.



WARNING

Workers MUST observe instructions, otherwise fatal or serious injuries to workers and other persons may occur.



WARNING

Workers must follow this instruction. Failing to do so may result in the death or serious bodily harm of workers or others.



CAUTION

Workers must observe this instruction since failing to do so may cause critical faults which can have impact on the engine performance and operation.

NOTE

NOTE: Indicates additional description, information, and references for workers' easy understanding.

Instructions

1. In order to maintain the best long term performance and safety, please read and understand this manual and perform routine inspections and regular inspections.
2. We have divided the content of this section into causes of bodily injury and damage to assets and causes of pollution.



When a safety accident, such as skin contact with corrosive acids or fuel, burns with hot oil, exposure of eyes to fuel or antifreeze, occurs while starting, inspecting, or repairing an engine, see a doctor immediately.

Cautions for Starting the Engine

1. Before starting the engine, please read this manual carefully and fully understand **Danger, Warning, and Caution**. If you cannot fully understand or have any questions, please contact us.
2. For safety reasons, attach warning signs around engines in operation to keep people other than workers from accessing the engines. Let engine operators know that they are responsible for the safety of the engine room.
3. Only authorized people may start and operate engines. Unauthorized people should not be allowed to handle engines.
4. Do not access running or rotating parts while the engine is in operation.
5. Be careful not to touch or contact the engine during operation since it becomes hot during operation.
6. Exhaust gas is poisonous. Fully ventilate area before starting engine. If the space is airtight, ensure that it is well ventilated.

Cautions for Inspection and Repair

1. Inspection and repair of engine should be performed only when the engine is shut down, otherwise, burns or safety accidents may occur. Do not perform inspection or repair while the engine is operating.
2. If it is absolutely necessary to perform inspection or repair on the operating engine, avoid the rotating parts.



When accessories such as necklaces, rings, watches, or gloves become stuck in rotating parts while the engine is operating, serious bodily injury may occur.

 **WARNING**

Do not exchange or disassemble a pipe or hose (from the engine fuel circuit, engine oil circuit, coolant circuit, or compressed air circuit) while the engine is operating. The leaked liquid may cause bodily injuries.

3. Use an engine oil drain container that is large enough to prevent the overflow of engine oil while draining engine oil.
4. Open the engine coolant cap after fully cooling the engine to exchange or replenish coolant.

 **WARNING**

If the coolant cap is opened while the engine is still hot, hot water will spurt out and may cause burns. Open the engine coolant cap after fully cooling the engine.

5. Fuel is highly flammable. Do NOT smoke or use open flame near engine.

 **WARNING**

Only refuel when the engine is shut down.

6. Mark and separately manage containers for storing coolant from beverage containers to avoid confusion. See a doctor immediately in case of drinking coolant.
7. Follow the instructions provided by the battery manufacturer when checking or handling batteries.

 **WARNING**

Battery fluid is corrosive and dangerous because of its explosiveness and toxicity. Therefore, it should only be handled by a skilled technician who specializes in battery fluid.

8. Only certified professional technicians should repair and maintain engines.
9. Only appropriate tools should be used. If the jaws of a wrench are worn out, the wrench might slip during use, causing safety accidents.
10. Do not allow other persons to stay or pass under an engine when lifting the engine with a crane. Before lifting the engine, ensure there is no one around the engine and reserve enough safety space.

11. Before inspecting or replacing an electrical apparatus, disconnect the battery Negative (-) cable first. Connect the battery Negative (-) cable after completing all required work for checking or replacing the electrical apparatus in order to prevent a short circuit.
12. Before performing electric welding works, turn off engine, block the power supply to the engine, and remove the wire harness connector connected to the engine control unit (ECU).
13. Do NOT give any electric or mechanical shocks or perform welding work on the electrical apparatus or the ECU.

General Repair

1. Wait until the engine is properly cooled before starting work otherwise, you may get burned by the heated engine. Before performing fuel line work, check the common rail pressure and engine temperature by using the failure diagnosis device.
2. Disconnect the battery Negative (-) cable to prevent damage of wires and sensors caused by a short circuit.
3. Engine oil and coolant may damage paint. Engine oil and coolant should be stored in separate containers and marked for safe management.
4. Store the disassembled parts in a specified space to avoid damage or contamination.
5. Use specified and special tools for efficient and safe repair.
6. If parts need to be replaced, use only genuine Doosan parts for replacement. Using unauthorized or non-factory remanufactured parts may cause critical damage and faults in engine performance.
7. Replace parts such as cotter pins, gaskets, o-rings, seal rings, oil seals, and washers with new ones during repairs. Reuse of parts may be the cause of engine faults and engine may not operate properly.
8. Group and store disassembled parts in disassembling order. Bolts and nuts vary in strength, shape, and torque according to their assembly position. Please divide and store them accordingly to these characteristics.
9. Clean disassembled parts to remove foreign substances before inspecting or reassembling parts. Use compressed air to clean the oil holes.
10. Thinly spread oil or grease on rotating parts or parts requiring lubrication, before assembly.
11. If required, use a specified adhesive to assemble gaskets to prevent water or oil from leaking.
12. Assemble bolts and nuts with the specified tightening torque.
13. After completing repairs, conduct a final inspection and perform a test operation to ensure all work has been successfully completed.

Environmental Pollution

Observe the following instructions to protect workers from danger and to prevent environmental pollution while performing engine repairs.

1. Good ventilation and low humidity should be maintained in the work space.
2. The workspace should be clean and in good order. No flammables are allowed in the workshop.
3. Smoking is strictly forbidden in the workshop.
4. Workers should wear work clothes, protective goggles, and safety shoes.
5. Workers are not allowed to wear accessories such as necklaces, rings, watches, and earrings.
6. Start the engine in a well ventilated space to prevent carbon monoxide poisoning.
7. Wait until the engine is properly cooled before starting work otherwise, you may get burned by the heated engine.
8. Do NOT work on rotating or operating parts once the engine has been started.
9. Discard oil according to the regulations set forth by the relevant authorities.
10. If engine oil or fuel leaks on the floor or is improperly discharged, serious environmental pollution of sea, river, or underground water may occur.
11. Discard the undiluted anticorrosive agent, antifreeze, filter elements, and cartridges as special waste.
12. Discard coolant and special waste according to the regulations of the appropriate authorities.



Failure to observe the regulations of the relevant authorities violates environmental pollution regulations and may be subject to legal penalties.

Use of Genuine Doosan Parts

An engine consists of many parts which are mechanically harmonized. To prevent future engine faults and ensure best performance for a long period, maintenance and replacement of expendable parts should be conducted regularly. Use of Doosan genuine parts is recommended. Using unauthorized or non-factory remanufactured parts may cause critical damage and faults to engine for which Doosan shall not be held liable.

Engine Management

Prevention of damage and abrasion

Using an engine for any purposes other than the designed purpose may cause critical faults to the engine for which Doosan shall not be held liable. For details concerning the usage and purpose of the engine, please direct questions to our Sales Team. Do NOT adjust, convert, or change the ECU without our authorization.

If a problem is found in an engine, research and solve the cause to prevent the critical faults in advance. Use of genuine Doosan parts is recommended. Using unauthorized or non-factory remanufactured parts may cause critical damage and faults to engine for which Doosan shall not be held liable.

Consider the following while managing engines.

1. Use clean, specified, and qualified fuel only. Use only fuel recommended in this Operation and Maintenance Manual.



Using inappropriate or unspecified fuel may cause critical damage, faults, and diminished engine performance.

2. Do not operate an engine without lubrication oil. Use only products (engine oil, cooling water, anticorrosive agent, and etc) recommended by Doosan.
3. Always keep surroundings of the engine clean.
4. Use fuel recommended in this Operation and Maintenance Manual.
5. Conduct inspections and exchanges regularly according to the regular inspection table.
6. If the engine is overheated, do not shut down immediately, but operate at idle status for five minutes or more to lower the engine temperature to the proper level.



If the radiator cap is opened while the engine is still hot, hot water will spurt out and may cause burns.

7. Check the engine oil level on a flat surface. Do not exceed the maximum of the oil level gauge.

 **CAUTION**

Immediately replenish engine oil when the engine oil level is below the lower limit of the engine oil gauge.

8. If there are gauges for battery, oil pressure, coolant, and temperature, check if they indicate a normal status.
9. Do not operate engine without coolant.

 **CAUTION**

Always use coolant mixed with antifreeze. If coolant without antifreeze is used, the coolant may freeze causing the coolant passage in the cylinder block to freeze and damage the engine.

Prevention of Pollution

Consider the following to manage engine without causing environmental pollution.

1. Discharge oil and coolant using collection containers.
2. Discard oil and coolant according to the regulations of the relevant authorities.
3. Be careful not to let discharged oil and cooling water flow into the ground or the sewer. Otherwise, serious pollution of the drinking water source may occur.
4. Classify the oil, filters, and filter cartridges as environmental pollution waste and discard them according to regulations.
5. Classify the antifreeze, cooling water, and anticorrosive agent as hazardous waste and discard them by observing the regulations.

Handling of Engine Oil

Prolonged and repeated contact of skin and engine oil may cause skin irritations. Engine oil includes substances toxic to the human body. Handle engine oil by observing the following safety rules:

1. Do not expose skin to engine oil for extended periods.
2. Always wear working clothes and gloves.
3. If skin comes in contact with engine oil, immediately clean skin with water, soap, or hand cleaners.
4. Do not clean skin with gasoline, fuel, thinner, or solvent.
5. Apply a protective skin cream after cleaning from oil.
6. Do not put oil stained gloves or cloth in pocket.



Discard oil according to the regulations set forth by the relevant authorities. Disposing of discharged oil into the ground, sewers, drains, rivers, or the sea will cause serious environmental pollution. Violation of regulations regarding discard of engine oil without observing the handling regulations may result in legal action.

Start and Shutdown

Start and Shut down of the Engine.

Preparing for Start

Check the following before starting the engine for the first time after purchase.

1. Before starting an engine, check the levels of fuel, coolant, and oil. Replenish those fluids if required.
2. Ensure engine oil level is between the upper and lower limit of the oil level gauge. The upper and lower limit of the oil level gauge indicate the maximum and minimum of the engine oil level.



When replenishing engine oil, do not exceed the maximum on the oil level gauge. Too much oil may cause damage to the engine.

3. Be careful not to mix foreign substances in fuel, engine oil, or coolant while injecting the fluid. Keep the fluid clean while it is not in use. Use fuel, oil, and coolant recommended by Doosan. Otherwise, critical damage to the engine may occur.

Starting the Engine

Observe the following when starting the engine.

1. For a cold start, start the engine after preheating it sufficiently through the glow plug.

After Starting the Engine

1. Operate engine at light load until engine has reached normal operating temperature.
2. Oil, air, or fuel leaks can cause a decrease in oil pressure. Oil leaks are especially likely to cause the burning of bearings. As such, if oil, air, or gas leaks occur, check the leaking parts and solve the problem.

During Operation

1. If oil pressure drops too low, it may cause abnormal wear and burning of bearings. If oil pressure is too high, it may cause oil leakage.
2. Continuing to operate the engine after noises or vibrations coming from the engine are noted may lead to serious engine damage. As such, if noises or vibrations come from the engine, slowly decrease the rpm to stop the engine and examine the cause.

Shutdown

Do not suddenly shut down the engine after it was operated under high loads for a long period. If oil burns because of heat sent from the high-temperature turbine blade to the bearing part, the bearing metal and rotating shaft may burn. As such, if the engine was operated under high loads for a long period, sufficiently run the engine at idle before shut down.

Break-in Period of Engine

Doosan engines are subjected to a final approval test to ensure the provision of high quality engines before being shipped. However, engines are not operated for a long period of time in this test. Therefore, new engines require a break-in period during the initial 50 hours after delivery. By properly breaking-in an engine, the highest levels of engine performance can be maintained long term.

If the engine's bearings are not properly broken in, they may be easily damaged and the lifetime of the engine may be shortened by overloading or high speeds. In order to prevent this, please follow the guidelines below for the initial 50 hours after delivery of new engine.

1. Fully warm up the engine until the engine temperature reaches the normal operation condition, before starting operation of the engine.
2. Do not overload the engine or operate it at too high RPM.
3. Do not operate the engine with high speed at idle.
4. Do not rapidly start up or shut down.
5. Do not operate the engine with less than 70% of the engine load.
6. Inspection, check, and repair of engines should be managed by officially certified technicians at certified service centers in compliance with corresponding rules.

Check Points

Check the following during the break-in period of a new engine.

1. Periodically check to verify the engine oil level is between the minimum and maximum limit of the oil level gauge.

CAUTION

If you cannot accurately check the oil level through the oil level gauge, rotate the oil level gauge to 180 degree, put it in the guide tube, and then pick it out again to check.

2. If the oil indicator lamp on the apparatus is lighted or blinks, the oil pressure may be insufficient. In this case, shutdown engine and check the oil level and replenish oil if required. When replenishing engine oil, do not exceed the maximum on the oil level gauge . If the oil level is normal, check other related parts such as the oil pressure sensor, oil pump, or oil line.

CAUTION

The oil pressure may increase with high rpm and decrease with low rpm. In addition, the pressure of cold oil may be higher at a specific rpm than of warm oil. This phenomenon may even occur when the engine operates properly.

3. Check the coolant gauge on the apparatus to ensure the coolant is circulating properly. If the coolant level in the supplementary tank is too low, the coolant gauge may be inaccurate.
4. Replace engine oil and oil filter after the break-in period.



If engine oil and oil filter need to be replaced, use only genuine engine oil and parts recommended by Doosan.

Operation after Break-in

Slowly preheat the engine when starting up during cold weather or in areas with cold climate. Do not rapidly raise the rpm while the engine has not been properly preheated. The engine consumes additional oil until its piston rings are positioned properly and operates successfully. Please check the engine oil level frequently for the initial 50 hours of the break-in period.

Inspection after Starting the Engine

Check the pressure of the engine lubrication system by using the engine oil pressure gauge mounted on the apparatus while the engine is in operation. If pressure decreases on oil pressure gauge, immediately shut down the engine. In addition, make sure that the recharge alarm indicator lamp of the alternator is off while the engine is operating.

1. Tightly connect the +/- terminals to prevent gaps. The sheath of battery connection cables should not be damaged or broken.
2. If the recharge alarm indicator lamp suddenly lights or blinks during engine operation and the engine shuts down, fix the fault of the electric apparatus.
3. If color or odor of exhaust gas is unusual during operation, shut down the engine, diagnose the cause and fix the fault.
4. Check the engine status through the alarm indicator lamp and gauges mounted on the apparatus during operation.

Engine Oil Pressure

If the engine oil pressure is not consistent at idle or does not reach the reference value while the engine is operating at high speed, immediately shut down the engine and check oil level and leakage.

Coolant Temperature

Operating an engine with too low coolant temperature increases fuel consumption, abrasion of the cylinder liner, and shortens the engine's life span.

Revolutions per Minute (rpm)

On an electronic control engine, the engine control unit (ECU) prevents the engine from being operated at too high rpm over the specifications to protect the engine. The memory of ECU has various functions which cannot be changed by operators, such as fuel flow control, ignition time delay, and blocking of fuel and ignition.

Operation in Winter

Preventing Coolant from Freezing

When only water used as coolant without mixing with antifreeze, corrosion in the engine, degradation of cooling efficiency, and freezing of the engine in winter may occur. If the engine is not operated for a long period during cold weather or in areas with cold climate, fully discharge the coolant from the engine. Freezing of coolant leads to critical damage to the engine. Please use a mixture of coolant with antifreeze at recommended ratio when replacing or replenishing the coolant. The antifreeze prevents coolant from freezing.

Preventing Overcooling of the Engine

When the engine is cooled below the normal operating temperature, thermal efficiency is lowered and fuel consumption as well as abrasion of the cylinder liner may increase. Therefore, the engine should be operated within the normal operating temperature. If the engine has been sufficiently operated, but the temperature of coolant remains below the normal operating temperature, check the water temperature controller or other parts related to the cooler.

Engine Oil

When viscosity of engine oil increases due to its low temperature during cold weather or in areas with cold climate, the rpm may not be stable after starting the engine. To prevent this, replace oil to engine oil for cold weather or areas with cold climate. When replacing engine oil, use only genuine engine oil recommended by Doosan.

Regular Inspection

General Information

Engine oil lubricates, cools, seals, prevents corrosion, and cleans engines, enhancing engine performance and extending the engine's lifetime. If the engine is continuously operated while engine oil is insufficient the moving parts of the engine may get stuck, causing engine faults.

Engine oil should be checked with the oil level gauge and replenished if required. Oil level should be checked while the engine is shut down. To check the oil level, shut down the engine and wait for 5 ~10 minutes to allow the engine oil to flow back into the oil pan. The engine oil level should indicate between the upper limit and the lower limit of the oil level gauge.

Engine oil should be periodically replaced based on the regular inspection table and the oil filter and the cartridge should be replaced as the engine oil is replaced.

Engine Oil Standards

Use the specified engine oil suitable for the environment and conditions of the site where the engine will be used.

Please use the engine oil which satisfies the following recommended specifications.

Engine Model	SAE Classification	Oil Class
DL01/DL02	SAE 10W30	API CJ-4 or Better
DL01/DL02	SAE 15W40	API CJ-4 or Better

Note: Doosan engine oils are recommended for use in this machine. If Doosan engine oil is not available, use a good quality engine oil that meets API service classification of CJ-4 or Better.

ENGINE OIL VISCOSITY BY TEMPERATURE

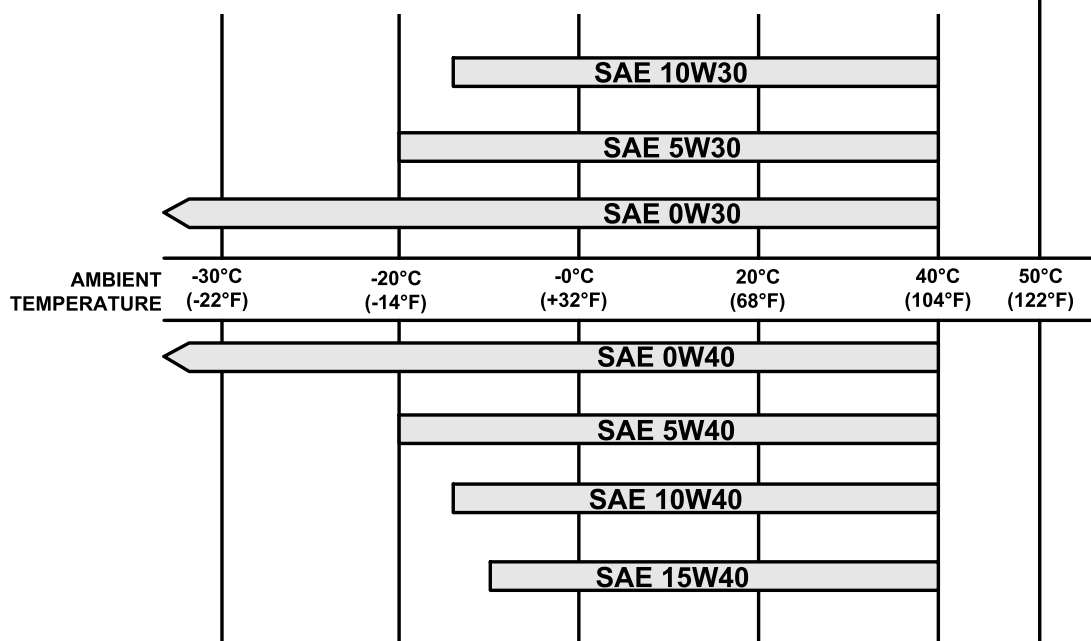

Checking the Engine Oil

1. Move the unit to a flat surface to maintain the engine level.
2. Start the engine and then shut down when it reaches the normal temperature.
3. Wait for 5 ~ 10 minutes.
4. Check the position of the oil level gauge (dipstick).
5. It is mounted between the oil filter and the alternator at the side of the engine as shown.

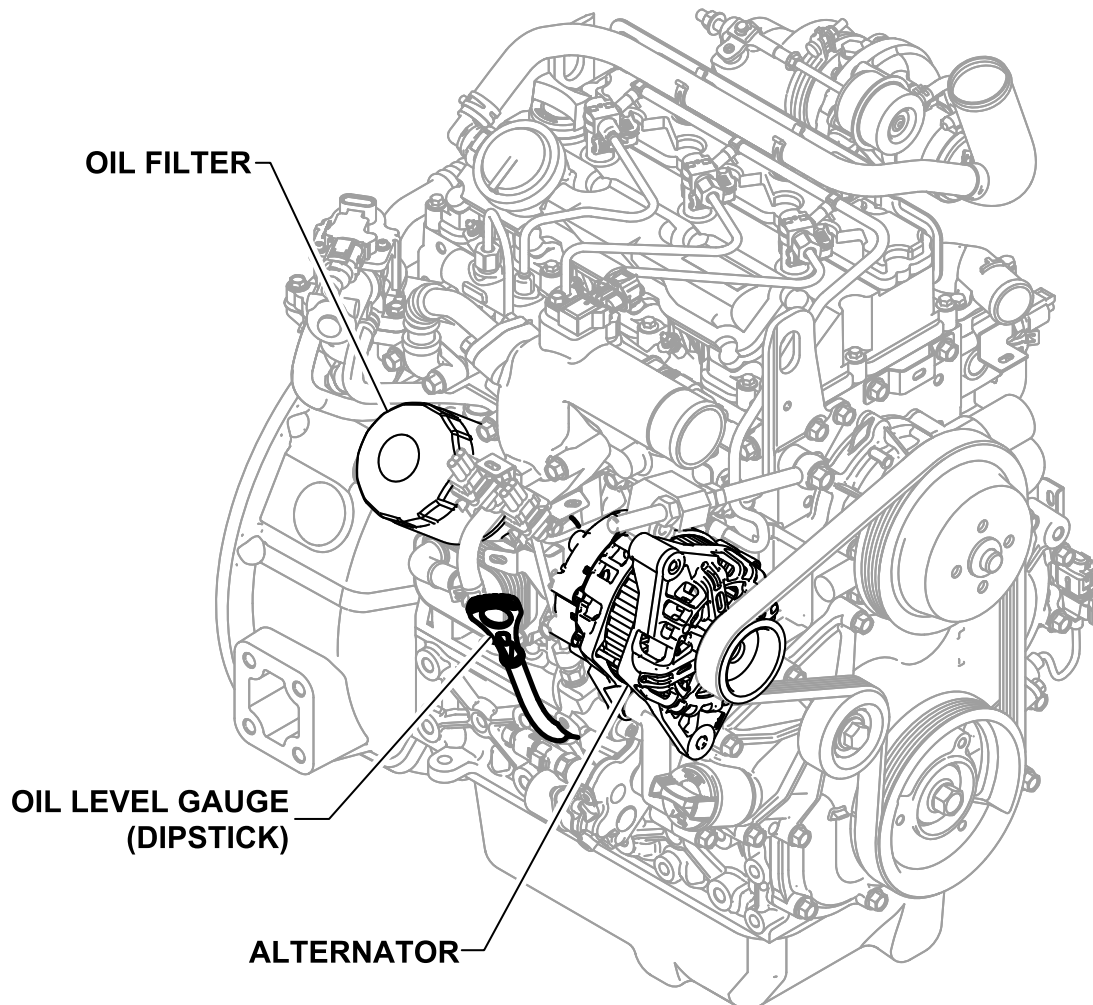

SHOWING OIL FILTER AND OIL LEVEL GAUGE LOCATION

Checking the Oil Level Gauge

1. Pull the oil level gauge (dipstick) upward to pick it out.
2. Pull the ring of the oil level gauge (dipstick) to pick it out.

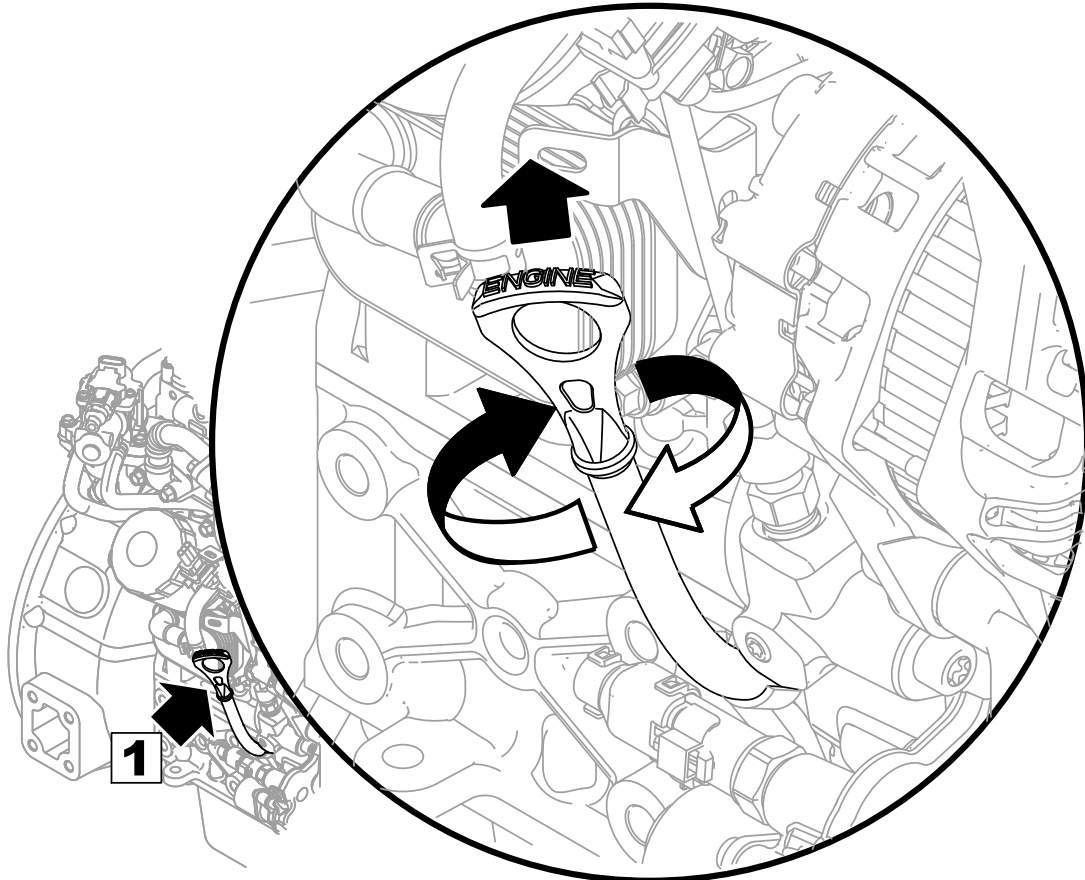

DETAIL 1

1. Clean the indication line of the oil level gauge (dipstick) with clean cloth.
2. Insert the oil level gauge (dipstick) again.
3. Insert the oil level gauge (dipstick) again by using the ring.
4. If the oil level gauge (dipstick) doesn't slide in, rotate it 180° and try again.

CAUTION

Cleaning the indication line of the oil level gauge with dirty cloth allows the foreign substances to get into the engine, causing engine faults.

1. Insert the oil level gauge (dipstick) again by using the ring.
2. If the dipstick doesn't slide in, rotate it 180° and try again.
3. Pull the oil level dipstick upward to remove.

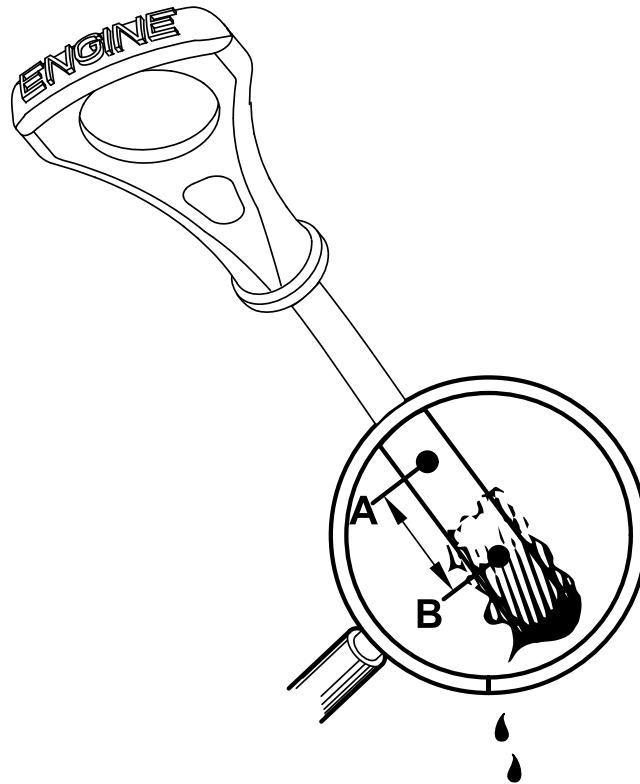

1. Check if the oil is smeared between the upper limit (a) and the lower limit (b) of the oil level gauge (dipstick) .
2. If engine oil is smeared below the lower limit (b) or not smeared on the gauge at all, replenish engine oil.
3. Check condition of engine oil. If it is polluted, replace it with new oil.

Replacement of Engine Oil

Special Tools

Tightening Torque

Component	Tightening Torque
Drain Plug	16–20 Nm

Oil Capacity

Crank Case Oil Capacity	2.4 gal (9.1 liters)
-------------------------	----------------------

Note: Including 0.6 Liter in the Engine.



Prolonged and repeated contact of skin with engine oil may lead to shrinking, dryness of skin and even cause dermatitis.

Do not expose skin with exchanged engine oil for a long period.

Always wear work clothes and gloves.

When skin is stained with engine oil, immediately wash with water, soap or hand cleaners.

Do not clean skin with gasoline, fuel, thinner, or solvent.

Apply a skin protective cream after cleaning.

Do not put oil-stained gloves or cloth in pockets.



Discard exchanged oil according to the regulations set forth by the relevant authorities. Disposing of discharged oil into the ground, sewers, drains, rivers, or the sea will cause serious environmental pollution. Violation of regulations regarding discard of engine oil without observing the handling regulations may result in legal action.

Drain Engine Oil

1. Place an appropriate sized container under the remote engine drain valve.
2. Open the drain valve and drain the engine oil.
3. Remove the oil cap.

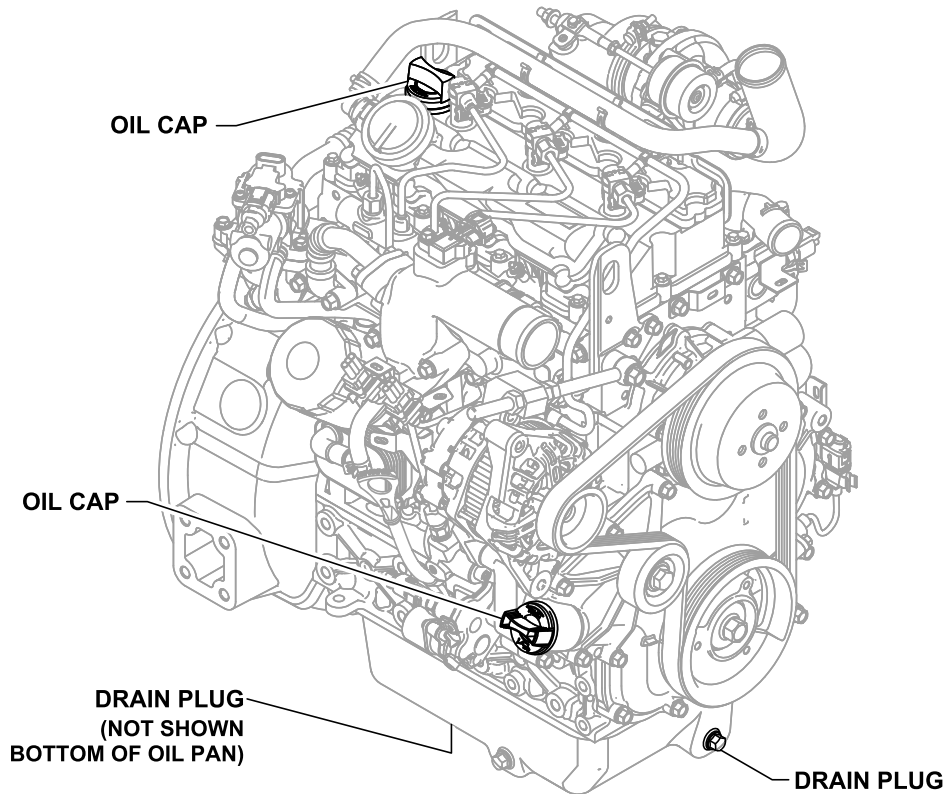
**SHOWING OIL CAP AND DRAIN LOCATIONS****⚠ CAUTION**

Oil in the filter may run down while detaching the oil filter. Be careful not to contaminate the other parts by using a cloth when detaching the filter. After replacing the oil filter, wipe clean any other parts which the oil has touched.

1. Disassemble oil filter with the filter wrench.
2. Cleanly wipe the surface on which the oil filter is mounted.
3. Thinly spread engine oil over the rubber packing of the new oil filter.
4. Temporarily assemble the new oil filter by rotating it by hand.
5. Assemble the oil filter with the filter wrench at a torque of 16 ~ 20 Nm.

6. Add the engine oil.

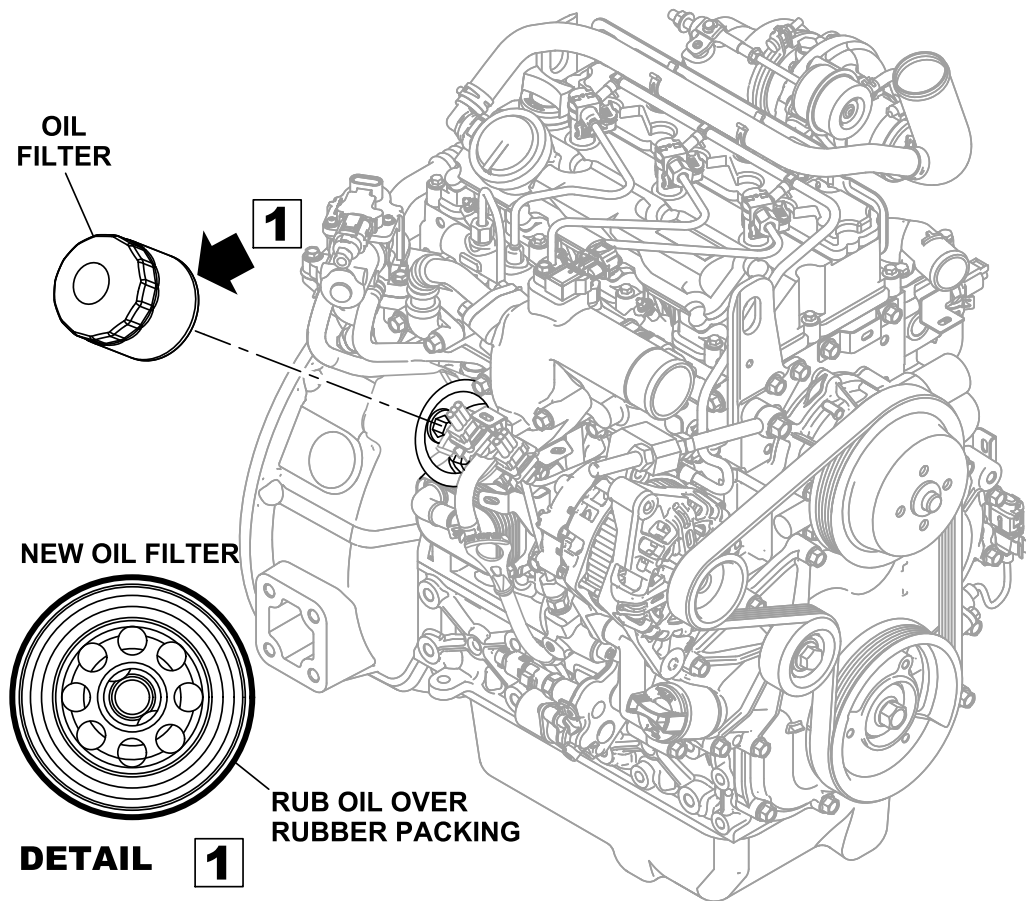

1. Connect the drain plug at the torque of 3.0 kgf·m.
2. Disassemble the oil level gauge (dipstick) .
3. Inject genuine oil recommended by Doosan.
4. Assemble the oil cap.
5. Assemble the oil level gauge (dipstick) .
6. Remove the engine oil drain container from under the drain valve.

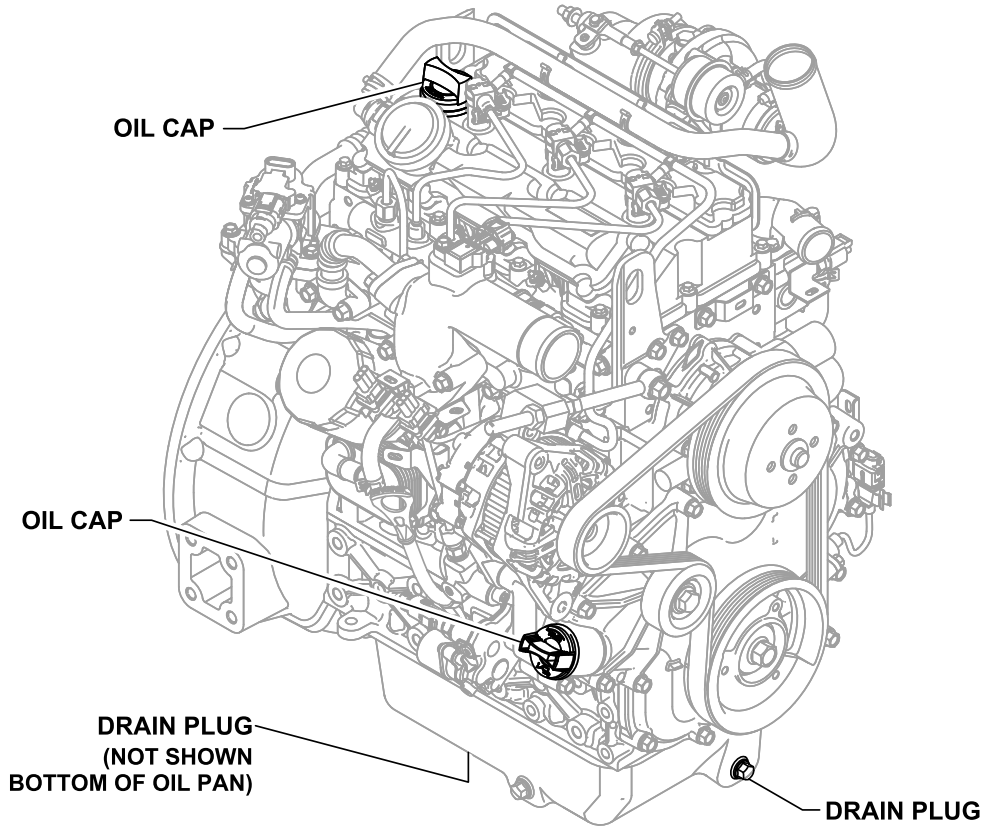

SHOWING OIL CAP AND DRAIN LOCATIONS

Perform the final inspection

1. Check if engine oil leaks after starting the engine.
2. Start the engine and then stop it when it reaches a normal temperature.
3. Wait for 5 ~ 10 minutes.
4. Check the engine oil level with the oil level gauge (dipstick) .

CAUTION

Adding oil which exceeds the upper limit of the oil level gauge may cause engine faults. If you have injected engine oil far over the upper limit of the oil level gauge, drain it until the engine oil level indicates somewhere between the upper and lower limit of the oil level gauge.

Coolant

General Information

The coolant plays an important role in the prevention of overheating and freezing of the engine. However, if the engine is used for a long period, the performance of antifreeze and anticorrosion of the coolant degrades. Maintain the condition of the coolant through daily inspections and periodic replacements. The mixing ratio for the engine coolant is 40 % antifreeze and 3~5 % additives (DCA4) to prevent corrosion. For the water in the coolant, use clean tap water. Periodically check coolant to maintain the concentration of antifreeze and additives.



The recommended mixing ratio allows coolant to prevent corrosion of the engine efficiently and to maintain the best engine performance for a long period. Using contaminated water or unspecified antifreeze or additives may cause critical faults in the cooler.

Ambient Temperature (°C)	Coolant (°C)	Antifreeze %
Above -10	85	15
-10	80	20
-15	73	27
-20	67	33
-25	60	40
-30	56	44
-40	50	50

Checking the Coolant



If the reservoir cap is opened to exchange or replenish coolant while the engine is overheated, hot water will spurt out and may cause serious burns. If it is absolutely necessary to open the reservoir cap while the engine is overheated, wrap the reservoir cap with a cloth and slowly open the reservoir cap in two steps until the steam pressure has been released from the inside. After the steam pressure has been completely released, remove the reservoir cap.

1. Make sure that the engine and radiator are cooled.
2. Check the level in the supplementary tank.
3. If the coolant level indicates between the upper limit and the lower limit on the supplementary tank, it means that the coolant volume is normal.
4. If there is insufficient coolant, replenish it.
5. Open the reservoir cap and check the condition of the coolant. If the coolant cap is contaminated or insufficient, measure the coolant concentration. If the coolant concentration is outside the specified range, exchange the coolant.

Measurement of Coolant Concentration

Special Tools

Figure	Product Number/Name
<p>test sheet</p> <p>C) B) A)</p>	<p>60.99901-0038 CC2602M (Fleet guard number) Coolant test sheet</p>

The Coolant concentration can be measured as follows:

1. If the Engine coolant temperature is within a range of 10 ~ 55° C, drain the Coolant.



When taking out a sample of coolant from the supplementary tank, it is difficult to measure the precise concentration. Always take out sample by opening the drain plug of coolant.

2. Soak the test sheet in the coolant and remove after 3 ~ 5 seconds. Shake the sheet to remove the remaining coolant.
3. Wait for about 45 seconds until the test sheet changes its color.



Measurement time should not exceed 75 seconds. The color changes as time passes.

4. Check the color on test sheet.

% GLYCOL / ANTIFREEZE (C) (END PAD)



-12° -15° -18° -21° -23° -29° -34° -43° -51° °C

SCA Units per Litre

Row 5	0.0	0.4	0.7	0.9	1.0	1.1	1.3	1.5
Row 5	0.0	0.4	0.6	0.7	0.9	0.9	1.1	1.3
Row 4	0.0	0.4	0.5	0.5	0.6	0.7	1.0	1.2
Row 3	0.0	0.3	0.4	0.4	0.6	0.7	0.9	1.1
Row 2	0.0	0.2	0.3	0.4	0.5	0.6	0.8	1.0
Row 1	0.0	0.2	0.2	0.2	0.4	0.5	0.7	0.9
Row C	0.0	0.1	0.2	0.2	0.3	0.4	0.6	0.9
MOLYBDATE (MIDDLE PAD)	A	B	C	D	E	F	G	H
	NITRITE							

1. Compare the color of part A on the test sheet to the color of GLYCOL/FREEZEPOINT (End pad) of the standard color table.
2. Compare the color of the test sheet (B) to the color of MOLYBDATE (Middle pad) of the standard color table.
3. Compare the color of the test sheet (C) to the color of NITRITE of the standard color table.

% GLYCOL / ANTIFREEZE (C) (END PAD)



-12° -15° -18° -21° -23° -29° -34° -43° -51 °C

SCA Units per Litre

		0.0	0.4	0.7	0.9	1.0	1.1	1.3	1.5	
Row E							TEST			
Row D		0.0	0.4	0.6	0.7	0.9	0.9	1.1	1.3	
Row 4		0.0	0.4	0.5	0.5	0.6	0.7	1.0	1.2	
		SERVICE								
Row 3		0.0	0.3	0.4	0.4	0.6	0.7	0.9	1.1	
Row 2		0.0	0.2	0.3	0.4	0.5	0.6	0.8	1.0	
Row 1		0.0	0.2	0.2	0.2	0.4	0.5	0.7	0.9	
		PRE CHARGE								
Row C		0.0	0.1	0.2	0.2	0.3	0.4	0.6	0.9	
MOLYBDATE (MIDDLE PAD)		A	B	C	D	E	F	G	H	
		NITRITE								

1. Compare the changed pink color part A of the test sheet with the GLYCOL/FREEZEPOINT (End pad) of the standard color table on top of the container and confirm the concentration. The concentration indication has to be within the color scope of 33~50%.
2. The state of additives for anticorrosion is shown on the point where the color of MOLYBDATE (Middle pad) on the standard color table (which is identical with the Middle (B) of the test sheet) is crossed with the color of NITRITE on the standard color table (which is identical with the (C) of the test sheet). It should be maintained at the optimum range, in the green section between 0.3 to 0.8.
3. If the measurement result is below 0.3, replenish anticorrosion additives (DCA4). If it is above 0.8 or, drain a little coolant and then inject clean tap water to adjust the concentration.



If the color on the test sheet does not match the color of the standard color table, find a middle color on the standard color table. For example, if the color of (C) of the test sheet matches D and F on the NITRITE of the standard color table, select E.

To prevent corrosion inside of the engine cooling unit, drain the coolant and replace it with new coolant once a year.

Replenishment of Coolant

If the coolant level of the supplementary tank is below the lower limit, replenish the coolant as follows:

1. Remove the supplementary tank cap.
2. Replenish coolant until level is between the upper and lower limit of the supplementary tank.
3. Install the supplementary tank cap.



Do NOT let foreign substances flow into the engine when replenishing coolant.

If there is no coolant in the supplementary tank, replenish the coolant as follows:

1. Remove the reservoir cap while the engine and radiator are cold.
2. Replenish coolant up to the inlet of the radiator.
3. After starting the engine let the coolant circulate sufficiently and check the coolant level. If there is insufficient coolant, replenish more.
4. Remove the supplementary tank cap.
5. Replenish coolant until its level is between the upper and lower limit of the supplementary tank.
6. Install the supplementary tank cap.



If the reservoir cap is opened while the engine is hot, hot water will spurt out and may cause serious burns. Open the reservoir cap after making sure that the engine has been fully cooled.

Mark and separately manage the containers for storing coolant from beverage containers for avoiding confusion. See a doctor immediately in case of drinking coolant.

Replacement of Coolant



Never open the reservoir cap while the engine is overheated. If the reservoir cap is opened while the engine is overheated, hot water will spurt out and may cause serious burns. Open the reservoir cap after ensuring that the engine has been cooled sufficiently.

Mark and separately manage the containers for storing coolant from beverage containers to avoid confusion. If coolant is ingested, see a doctor immediately.



Be careful not to get coolant on any belts or electric apparatus when replacing the coolant.

1. Make sure that engine and radiator are cooled.
2. Place an appropriate size container in front of the coolant drain plug.
3. Remove the reservoir cap.
4. Unplug the coolant drain plug of the radiator and drain coolant.
5. After completing coolant drain, connect the coolant drain plug.
6. Drain the coolant from the coolant supplementary tank and cleanse the tank.
7. Fill the radiator inlet with water and install reservoir cap.

Note: slowly pour coolant in to let the air be discharged from radiator and press the hose connected to it to discharge the air inside.

8. Start the engine to let the cooling fan rotate 2 or 3 times. When the engine is warmed up, increase the engine rpm two or three times.
9. Shut down engine and wait until engine is cooled.
10. Remove the radiator drain plug and drain water.
11. Repeat steps 1–8 until the drained water becomes clear.
12. Press the hose connected to the radiator to discharge the air from inside of the radiator and slowly fill the radiator with the coolant at the specified mixing ratio to let the air be discharged from the radiator.

Note: Use recommended genuine antifreeze.

 **CAUTION**

Do not mix antifreezes from different manufacturers.

Do not mix the coolant with different concentrations.

Do not add antirust which is not recommended by us.

As insufficient coolant concentration may cause corrosion or freezing. However, an excessive concentration may degrade the cooling performance. Mix coolant with 40% antifreeze and 3~5% additives (DCA4) to prevent corrosion.

13. Operate the engine at idle after starting. When cooling fan is running and coolant is circulated, remove radiator cap and replenish coolant through the inlet.
14. Replenish coolant until the cooling fan rotates 3 ~ 5 times.
15. Replenish coolant to the upper limit of the supplementary tank and then install radiator cap.
16. Operate the engine at idle until the cooling fan rotates 2 ~ 3 times.
17. Shut down the engine and wait until the engine and radiator are cooled.
18. After checking the coolant level in the supplementary tank, replenish coolant until the tank level stays between the upper and lower limit without changing.

 **CAUTION**

After replenishing coolant, check the coolant level of the supplementary tank for at least two or three days.

 **WARNING**

Discard exchanged coolant to the regulations set forth by the relevant authorities. Disposing of exchanged coolant into the ground, sewers, drains, rivers or the sea will cause serious environmental pollution. Violation of regulations regarding discard of coolant without observing the handling regulations may result in legal action.



Lubrication

Lubrication

Lubrication is an essential part of preventive maintenance, affecting to a great extent the useful life of the compressor. Different lubricants are needed and some components require more frequent lubrication than others. Therefore, it is important that the instructions regarding types of lubricants and the frequency of their application be explicitly followed. Periodic lubrication of the moving parts reduces to a minimum the possibility of mechanical failures.

The Maintenance Schedule shows those items requiring regular service and the interval in which they should be performed. A regular service program should be developed to include all items and fluids. These intervals are based on average operating conditions. In the event of extremely severe (hot, cold, dusty or wet) operating conditions, more frequent lubrication than specified may be necessary.

All filters and filter elements for air and compressor oil must be obtained through Portable Power to assure the proper size and filtration for the compressor.

Compressor Oil Chart

Refer to this chart for the correct compressor oil required. Note that the selection of oil is dependent on the rated operating pressure of the compressor and the ambient temperature expected to be encountered before the next oil change.

Note: Oils listed as “preferred” are required for extended warranty.

Compressor oil carryover (oil consumption) may be greater with the use of alternative oils.

Rated Operating Pressure	Ambient Temperature	Compressor Oil Specification
100 psi to 300 psi	-10°F to 125°F (-23°C to 52°C)	Preferred: PRO-TEC™ Alternate: ISO Viscosity Grade 46 PAO, with rust and oxidation inhibitors, for rotary screw compressor service.
350 psi	(-23°C to 52°C) (-10°F to 125°F) 65°F to 125°F (18°C to 52°C)	Preferred: PRO-TEC™ XHP605 Alternate: XHP405 ISO Viscosity Grade 68 Group 3 or 5 with rust and oxidation inhibitors designed for air compressor service. Preferred: XHP605 XHP1001

Preferred Oil - Use of these oils with Doosan branded filters can extend airtend warranty. Refer to the warranty policy for details or contact your representative.

Preferred Oil	1 gal. (3.8 Liter)	5 gal. (19.0 Liter)	55 gal. (208 Liter)	275 gal. (1041 Liter)
Pro-Tec™	36899698	36899706	36899714	36899722
XHP605	-	22252076	22252050	22252068
XHP1001	-	35612738	35300516	-
XHP405	-	22252126	22252100	22252118



Maintenance

General Information

CAUTION

Any unauthorized modification or failure to maintain this equipment may make it unsafe and out of factory warranty.

If performing more than visual inspections, disconnect battery cables and open manual blowdown valve.

Use extreme care to avoid contacting hot surfaces (engine exhaust manifold, piping, air receiver, and air discharge piping, etc.).

Never operate this machine with any guards removed.

Inch and metric hardware was used in the design and assembly of this unit. Consult the parts manual for clarification of usage.

NOTICE

Disregard any maintenance pertaining to components not provided on your machine.

In addition to periodic inspections, many of the components in these units require periodic servicing to provide maximum output and performance. Servicing may consist of pre-operation and post-operation procedures to be performed by the operating or maintenance personnel. The primary function of preventive maintenance is to prevent failure, and consequently, the need for repair. Preventive maintenance is the easiest and the least expensive type of maintenance. Maintaining your unit and keeping it clean at all times will facilitate servicing.

Scheduled Maintenance

The maintenance schedule is based on normal operation of the unit. This page can be reproduced and used as a checklist by the service personnel. In the event unusual environmental operating conditions exist, the schedule should be adjusted accordingly.

Compressor Oil Level

Check the compressor fluid level when the machine is not operating. Maintain the fluid level between bottom and midway of the sight glass on the separator tank.

Air Cleaner

To service the air cleaners on all units proceed as follows:

1. Loosen the 2 latches on the sides of the air cleaner cover.
2. Remove air cleaner body.
3. Pull out air cleaner element.

4. Pull out safety element if installed.
5. Install new filters in air cleaner body.
6. Re-install cover on air cleaner body.
7. Close the 2 latches after securing to air cleaner body.

Make sure that all clamps and flange joints are tight. Make sure the pre-cleaner dirt dump is pointed within 30° of down.

Gauges

The instruments or gauges are essential for safety, maximum productivity and long service life of the machine. Inspect the gauges and test any diagnostic lamps prior to start-up. During operation observe the gauges and any lamps for proper functioning. Refer to Operating Controls, for the normal readings.

Fuel Tank

CLEAN fuel in the fuel tanks is vitally important and every precaution should be taken to ensure that only clean fuel is poured or pumped into the tank.

When filling the fuel tank on this unit, by methods other than a pump and hose, use a CLEAN non-metallic funnel.

Battery

Keep the battery posts-to-cable connections clean, tight and lightly coated with a grease. Also the electrolyte level in each cell should cover the top of the plates. If necessary, top-up with clean distilled water.

Tires

A weekly inspection is recommended. Tires that have cuts or cracks or little tread should be repaired or replaced. Monthly check the wheel lug nuts for tightness.

Fasteners

Visually check entire unit in regard to bolts, nuts and screws being properly secured. Spot check several capscrews and nuts for proper torque. If any are found loose, a more thorough inspection must be made. Take corrective action.

Wheel Torque Chart	
M12 Bolts	Torque (Ft-Lbs)
13" Wheel	60-70
1/2" Lug Nuts	
13" Wheel	80-90
15" Wheel	105-115
16" Wheel	105-115
16.5" Wheel	105-115
5/8" Lug Nuts	
16" Wheel	190-210
17.5" Wheel	190-210

Radiator

NOTICE

The use of water alone in this engine can result in major engine failure. Refer to engine section for coolant recommendation.

Hoses

Each month it is recommended that all of the intake lines to and from the air cleaners, the engine cooling system hoses and all of the flexible hoses used for air, oil, and fuel be inspected.

To ensure freedom from air leaks, all rubber hose joints and the screw-type hose clamps must be absolutely tight. Regular inspection of these connections for wear or deterioration is necessary.

Premature wear of both the engine and compressor is ASSURED whenever dust-laden air is permitted to enter the engine's combustion chamber or compressor intake.

NOTICE

Some of the air lines are nylon tubing. The associated fittings are "push-in" design. Features are as follows:

Pulling on the tubing will cause the inner sleeve to withdraw and compress, thus tightening the connection. The tubing can be withdrawn only while holding the sleeve against the fitting. The tubing can be removed and replaced numerous times without losing its sealing ability.

To install the nylon tubing, make a mark (with tape or grease pencil) approximately 7/8 inch from the end of the tubing. Insert the tubing into the sleeve and "push-in" past the first resistance to the bottom. The mark should be approximately 1/16 inch from the sleeve, for the 3/8 inch O.D. tubing; 1/8 inch for the 0.25 inch O.D. tubing. This will ensure that tubing is fully engaged in the sealing mechanism.

Compressor Oil Filters

The oil filter must be replaced every 500 hours of operation or six (6) months, whichever comes first.

To service oil filters it will first be necessary to shut the unit down. Wipe off any external dirt and oil from the exterior of the filter to minimize any contamination from entering the lubrication system. Proceed as follows:

Removal



High Pressure Air can cause severe injury or death from hot oil and flying parts. Always relieve pressure before removing caps, plugs, covers or other parts from pressurized air system.

1. Open the service air valve(s) to ensure that system is relieved of all pressure. Close the valve(s).
2. Turn the spin-on filter element counterclockwise to remove it from the filter housing. Inspect the filter.
3. Inspect the oil filter head to be sure the gasket was removed with the oil filter element. Clean the gasket seal area on the oil filter head.

NOTICE

Installing A New Oil Filter Element When The Old Gasket Remains On The Filter Head Will Cause An Oil Leak And Can Cause Property Damage.

4. Lubricate the new filter gasket with the same oil being used in the machine.
5. Install new filter by turning the element clockwise until gasket makes initial contact. Tighten an additional 1/2 to 3/4 turn.
6. Start unit and allow to build up to rated pressure. Check for leaks before placing unit back into service

Compressor Oil Cooler

The compressor lubricating and cooling oil is cooled by means of the fin and tube-type oil cooler, located beside the radiator. The lubricating and cooling oil, flowing internally through the core section, is cooled by the air stream from the cooling fan flowing past the core section. When grease, oil and dirt accumulate on the exterior surfaces of the oil cooler, its efficiency is impaired.

Each month it is recommended that the oil cooler be cleaned by directing compressed air which contains a nonflammable, non-caustic safety solvent through the core of the oil cooler. This should remove the accumulation of grease, oil and dirt from the exterior surfaces of the oil cooler core so that the entire cooling area can transmit the heat of the lubricating and cooling oil to air stream.

In the event foreign deposits, such as sludge and lacquer, accumulate in the oil cooler to the extent that its cooling efficiency is impaired, a resulting high discharge air temperature is likely to occur, causing shut down of the unit. To correct this situation it will be necessary to clean it using a cleaning compound in accordance with the manufacturer's recommendations.

Compressor Oil

The lubricating and cooling oil must be replaced every 500 hours of operation or six (6) months, whichever comes first. Refer to warranty section about extended warranty.

Receiver Separator System



High pressure air can cause severe injury or death from hot oil and flying parts. Always relieve pressure before removing caps, plugs, covers or other parts from pressurized air system.

- Open service valve at end of machine.
- Ensure pressure is relieved, with BOTH:
 - Discharge air pressure gauge reads zero (0).
 - No air discharging from service valve.

Remove plug near bottom of separator tank to drain compressor oil.

When adding oil, remove and replace (make tight) plug on top of separator tank.

The life of the oil separator element is dependent upon the operating environment (soot, dust, etc.) and should be replaced every twelve months or 1000 hours. To replace the element proceed as follows:

- Ensure the tank pressure is zero.
- Unscrew separator element from manifold.
- Lubricate gasket with compressor oil. Install new element.

Scavenge Line



High Pressure Air can cause severe injury or death from hot oil and flying parts. Always relieve pressure before removing caps, plugs, covers or other parts from pressurized air system.

The scavenge line originates at the manifold and terminates at the compressor airend near the oil filter element. An orifice check valve is located on the scavenge tube.

Once a year or every 1000 hours of operation, whichever comes first, replace the separator element and clean the scavenge orifice/check valve.

NOTE: Excessive oil carry-over may be caused by an oil-logged separator element. Do not replace element without first performing the following maintenance procedure:

1. Check oil level. Maintain as indicated earlier in this section.
2. Thoroughly clean scavenge line, any orifice and check valve.
3. Assure minimum pressure valve/orifice is operational.
4. Run unit at rated operating pressure for 30 to 40 minutes to permit element to clear itself.

Exterior Finish Care

This unit was painted and heat cured at the factory with a high quality, thermoset polyester powder coating. The following care will ensure the longest possible life from this finish.

1. If necessary to remove dust, pollen, etc. from housing, wash with water and soap or dish washing liquid detergent. Do not scrub with a rough cloth, pad, etc.
2. If grease removal is needed, a fast evaporating alcohol or chlorinated solvent can be used. Note: This may cause some dulling of the paint finish.
3. If the paint has faded or chalked, the use of a commercial grade, nonabrasive automotive car wax may partially restore the color and gloss.

Field Repair of Texture Paint

1. The sheet metal should be washed and clean of foreign material and then thoroughly dried.
2. Clean and remove all grease and wax from the area to be painted using Dupont 3900S Cleaner prior to sanding.
3. Use 320 grit sanding paper to repair any scratches or defects necessary.
4. Scuff sand the entire area to be painted with a red Scotch Brite™ pad.
5. Wipe the area clean using Dupont 3900S.

6. Blow and tack the area to be painted.
7. Apply a smooth coat of Dupont 1854S Tuffcoat Primer to all bare metal areas and allow to dry.
8. Apply 2 medium - wet coats of Dupont 222S Adhesion Promoter over the entire area to be painted, with a 5 minute flash in between coats.
9. To apply the texture coat, use Dupont 1854S Tuffcoat Primer. The proper technique to do this is to spray the Tuffcoat Primer using a pressure pot and use about 2-5 pounds of air pressure. This will allow the primer to splatter causing the textured look.

NOTE: You must be careful not to put too much primer on at one time, this will effect the amount of texture that you are trying to achieve. Allow the texture coat to flash for 20 minutes or until dry to touch.

10. Apply any Dupont Topcoat Finish such as Imron™ or Centari™ according to the label instructions.

NOTE: To re-topcoat the textured surfaces when sheet metal repairs are not necessary, follow steps 1, 2, 4, 5, 6, 8 and 10.

Field Replacement of Exterior Decals

Field Replacement of Enclosure Decals

1. The decal area should be wiped with 70% isopropyl alcohol and a lint free cloth, in a well ventilated area.
2. Allow sufficient time for drying, but not enough time for dust to resettle on surface.
3. Align decals prior to removing the backing.
4. Peel one section of backing from decal, while still aligned, and squeegee decal from center of the edges, to remove air.
5. Remove the remaining backing and repeat squeegee process.
6. Repeat squeegee process over entire decal surface to ensure a tight bond. Allow 24 hours for permanent bond.
7. Any air bubbles may be removed by pricking the bubble center with a pin and squeegee air toward the hole.

Preventive Maintenance Schedule

Preventive Maintenance Schedule - Front

C185WDO-T4F

PREVENTIVE MAINTENANCE SCHEDULE									
INITIAL 500 Miles / 800 km									
Maintenance Item	DAILY	WKLY	MO.	3 MOS. 250 Hrs	6 MOS. 500 Hrs	12 MOS. 1000 Hrs	24 MOS. 2000 Hrs	48 MOS. 5000 Hrs	
Brakes									
Brakes Linkage									
Compressor Oil Level	C								
Engine Oil Level	C								
Radiator Coolant Level	C								
Gauges / Lamps	C								
Air Cleaner Service Indicators	C								
Fuel Tank (Fill At End Of Day)	C				D				
Fuel / Water Separator Drain	C								
Oil Leaks	C								
Fuel Leaks	C								
Drain Water From Fuel Filters	D								
Coolant Leaks	C								
Radiator Filler Cap	C								
Lubricator (Fill)	C								
Air Cleaner Precleaner Dumps	C								
Fan / Alternator Belts	C								
Battery Connection / Electrolyte	C								
Tire Pressure and Condition	C								
Wheel Lug Nuts	C								
Hose (Oil, Air, Intake, etc.)	C								
Automatic Shutdown System	C								
Air Cleaner System	C								
Compressor Oil Cooler Exterior	C								
Engine Radiator / Oil Exterior	C								
Safety Valve	C								
Fastners, Guards	C								
Air Cleaner Elements	R / WI								
Fuel / Water Separator Element	R								
Compressor Oil Filter Element	R								

Maintenance Interval Kits	
46728845	500 Hours
46728847	1000 Hours
Consumables	
46680086	Compressor Oil Filter Element
46652735	Compressor Separator Filter Element
46707046	Primary Air Filter Element
46707047	Secondary Air Filter Element
46668934	Engine Oil Filter Element
46664396	Engine Fuel Filter Element
46845493	Pre-Fuel Filter
Remanufactured Aircends	
RECOMMENDED DOOSAN FLUIDS:	
Use of these fluids with original Doosan filters can extend warranty.	
Refer to warranty brochure for details or contact your Doosan Representative.	
COMPRESSOR FLUID	1 Gal. (3.8 Litre) 5 Gal. (19.0 Litre) 55 Gal. (208.2 Litre) 220 Gal. (836 Litre)
Doosan Pro-Tec™	36899698 36899706 36899714
ENGINE FLUID	1 Gal. (3.8 Litre) 5 Gal. (19.0 Litre) 55 Gal. (208.2 Litre) 220 Gal. (836 Litre)
Doosan Tier 4	46557017 46557016 46557015

Legend:

CBT = Check Before Towing
 G = Grease
 C = Check (and Adjust or Replace if Necessary)

R = Replace
 T = Test
 D = Drain

WI = or When Indicated
 CR = Check & Report

(Continued On Back)

For Parts, Service & Nearest Distributor
 Call: 1-800-633-5206

Pro-Tec - T.M. of DOOSAN



Troubleshooting

Introduction

Troubleshooting for a Portable Air Compressor is an organized study of a particular problem or series of problems and a planned method of procedure for investigation and correction. The Troubleshooting Chart that follows includes some of the problems that an operator may encounter during the operation of a Portable Compressor.

The Chart does not attempt to list all of the troubles that may occur, nor does it attempt to give all of the answers for correction of the problems. The chart does give those problems that are most apt to occur. To use the Troubleshooting Chart:

- A. Find the "Complaint" depicted as a bold heading.
- B. Follow down that column to find the potential cause or causes. The causes are listed in order to suggest an order to follow in Troubleshooting.

Think Before Acting

Study the problem thoroughly and ask yourself these questions:

1. What Were The Warning Signals That Preceded The Trouble?
2. Has A Similar Trouble Occurred Before?
3. What Previous Maintenance Work Has Been Done?
4. If The Compressor Will Still Operate, Is It Safe To Continue Operating It To Make Further Checks?

Do The Simplest Things First

Most troubles are simple and easily corrected. For example, most complaints are "Low Capacity" which may be caused by too low an Engine speed or "Compressor over-heats" which may be caused by Low Oil level.

Always check the easiest and most obvious things first; following this simple rule will save time and trouble.

Double Check Before Disassembly

The source of most Compressor troubles can be traced not to one component alone, but to the relationship of one component with another. Too often, a Compressor can be partially disassembled in search of the cause of a certain trouble and all evidence is destroyed during disassembly. Check again to be sure an easy solution to the problem has not been overlooked.

Find And Correct Basic Cause

After a mechanical failure has been corrected, be sure to locate and correct the cause of the trouble so the same failure will not be repeated. For example, a complaint of "premature breakdown" may be corrected by repairing any improper wiring connections, but something caused the defective wiring. The cause may be excessive vibration.

Troubleshooting Chart

Complaint	Cause	Correction
1. Compressor has stopped unexpectedly	Out of Fuel.	Add Clean Fuel.
	Compressor Oil Temp. too high.	See Complaint #6.
	Engine Coolant Temp. too high.	Check Coolant level. If low, add Coolant. See Complaint #3.
	Engine Oil Pressure too low.	See Complaint #4.
	Loose or Broken Belts.	Tighten or replace belt set.
	Loose wire connections.	Check wires at switches and connectors to find loose connection. Make repairs. See Electronic Service Manual.
	Low fuel level fault.	If adequate fuel in the tank, check fuel level sender device. Replace if determined faulty. See Electronic Service Manual.
	Defective sensor.	Identify and check sensor. Replace if necessary. See Electronic Service Manual.
	Malfunctioning relay.	Identify and check relay. Replace if necessary. See Electronic Service Manual.
	Blown fuse.	Identify and replace fuse. See Electronic Service Manual.
	Engine malfunctioning.	See troubleshooting in Engine manual.
Airend malfunctioning.	See Complaint #6.	
2. Compressor won't Start or Run	Low battery voltage.	Check battery condition, recharge if necessary. Check electrolyte level, add if necessary. Check cable connections, clean and tighten as needed.
	Blown fuse.	Identify and replace fuse. See Electronic Service Manual.

	Malfunctioning main power switch.	Check switch. Replace if necessary. See Electronic Service Manual.
	Clogged fuel filters.	Service fuel filters. See Engine Manual.
	Out of Fuel.	Add clean fuel.
	Compressor oil temp. too high.	See Complaint #6.
	Engine coolant temp. too high.	Check coolant level. If low, add coolant. See Complaint #3.
	Engine oil pressure too low.	See Complaint #4.
	Loose wire connection.	Check wires at switches and connectors to find loose connection. Make repairs. See Electronic Service Manual.
	Defective sensor.	Identify and check sensor. Replace if necessary. See Electronic Service Manual.
	Malfunctioning relay.	Identify and check relay. Replace if necessary. See Electronic Service Manual
	Engine malfunctioning.	See troubleshooting in Engine manual.
	Airend malfunctioning.	See Complaint #6.
	Starter will not turn engine over.	Check battery, check fuel. Engine will not crank without 40 psi of fuel pressure.
3. Low Engine Oil Pressure	Low engine oil level.	Check oil level. If low, add oil.
	Compressor tilted beyond out-of-level operating limit.	Reposition or relocate compressor to be more level.
	Wrong engine oil.	Change engine oil. Review engine oil specification.
	Clogged engine oil filter.	Replace engine oil filter.
	Engine malfunctioning.	See troubleshooting in Engine Manual.
	Loose wire connection.	Check wires at switches and connectors to find loose connection. Make repairs. See Electronic Service Manual.

4. Low Electrical System Voltage	Loose or broken belts.	Tighten or replace belt set.
	Loose wire connection.	Check wires at switches and connectors to find loose connection. Make repairs. See Electronic Service Manual.
	Low battery voltage.	Check battery condition, recharge if necessary. Check electrolyte level, add if necessary. Check cable connections, clean and tighten as needed.
	Malfunctioning alternator.	Repair or replace alternator.
5. High Compressor Oil Temperature	Ambient temperature above rated ambient temperature range.	Operate in cooler environment.
	Compressor tilted beyond out-of-level operating limit.	Reposition or relocate compressor to be more level.
	Low compressor oil.	Add compressor oil. Look for and repair any leaks.
	Wrong compressor oil.	Change compressor oil. Review compressor oil specification.
	Dirty cooler(s).	Clean exterior of cooler(s).
	Dirty operating conditions.	Move compressor to cleaner environment.
	Clogged compressor oil filter(s).	Replace compressor oil filter(s) and change compressor oil.
	Operating pressure too high.	Reduce pressure to rated operating pressure.
	Recirculation of cooling air.	Close enclosure doors. Close and secure access panels. Check for loose or missing belly pans.
	Malfunctioning compressor oil thermostat.	Replace thermostat element in conventional bypass valve, if equipped. Replace valve.
	No air flow.	Check electric fans to ensure they are operating.
	Malfunctioning minimum pressure valve.	Repair or replace valve.

	Blocked or restricted oil lines.	Clean by flushing, or replace lines.
	Airend malfunctioning.	See Complaints #11, #12.
6. Low Engine Speed	Clogged fuel filters.	Service fuel filters. See Engine Manual. Drain and clean fuel tanks. Add clean fuel.
	Operating pressure too high.	Reduce pressure to rated operating pressure.
	Clogged air filter element(s).	Clean or replace air filter element(s).
	Wrong air filter elements(s).	Install correct air filter element(s).
	Engine malfunctioning.	See troubleshooting in Engine manual.
	Airend Malfunctioning.	See Complaints #11, #12.
7. Excessive vibration	Rubber mounting isolators loose or damaged.	Tighten or replace.
	Defective or imbalanced fan.	Replace fan.
	Defective airend drive coupling.	Replace coupling.
	Engine malfunctioning.	See troubleshooting in Engine Manual.
	Airend malfunctioning.	See Complaint #7, #11, #12.
	Engine idle speed too low.	See Complaint #7. See Engine Manual.
8. Low Air Delivery/Low cfm	Clogged air filter element(s).	Clean or replace air filter element(s).
	Incorrect pressure regulation adjustment.	Make adjustment per this manual.
	Malfunctioning inlet unloader/butterfly valve.	Inspect valve. Make adjustments per this manual.
	Wrong air filter element(s).	Install correct air filter element(s).
	Low engine speed.	See Complaint #7. See Engine Manual.
	Compressed air leaks.	Locate and repair leaks.

9. Short Air Filter Life	Dirty operating conditions.	Move compressor to cleaner environment.
	Wrong air filter element(s).	Install correct air filter element(s).
	Inadequate air filter element cleaning.	Install new air filter element(s).
	Incorrect stopping procedure.	Comply with procedure in this manual.
10. Compressor will not unload	Malfunctioning inlet unloader.	Inspect valve. Make adjustments per this manual.
	Malfunctioning pressure regulator.	Check pressure regulator. Check regulation lines for leaks.
	Ice in regulation lines and/or regulation orifice.	Apply heat to lines and or orifice. Check operation of DC electric heaters, if equipped.
	Plugged vent leak.	Clean and/or replace.
11. Safety Valve Opens	Operating pressure too high.	Reduce pressure to rated operating pressure.
	Malfunctioning inlet unloader.	Inspect valve. Make adjustments per this manual.
	Defective safety valve.	Replace safety valve.
	Compressor will not unload fast enough.	Check pressure regulator. Check regulation lines for leaks.
	Ice in regulation lines and/or regulation orifice.	Apply heat to lines and/or orifice. Check operation of DC electric heaters, if equipped.
12. Excessive carryover (Compressor Oil in the Compressed Air).	Blocked separator scavenge line.	Check scavenge line, drop tube, and orifice. Clean and replace as needed.
	Deteriorated separator element.	Replace separator element.
	Separator tank pressure too low.	Check the minimum pressure valve. Repair or replace as necessary.

Diagnostic Codes

The Mirco-Port Displays Diagnostic Codes For The Compressor System And The Engine. Listings Of These Codes Are Provided In This Section.

The Engine Diagnostic Codes Can Also Be Read With The Engine Manufacturer'S Service Tool. A Service Tool Connector Is Provided In The Electrical Harness, Providing Access To The J1939 Can Network. For Advanced Engine Troubleshooting, It Is Recommended The Manufacturer'S Service Tools And Service Literature Be Used.

Compressor Diagnostic Codes

LCD Display	Display Name	Description	Type
CPR CODE 1 LOW ENGINE SPEED	Low Engine Speed	Engine speed less than 1300 RPM for 30 seconds.	FAULT
CPR CODE 2 HIGH ENGINE SPEED	High Engine Speed	Engine speed greater than 2720 RPM for 30 seconds.	FAULT
CPR CODE 3 WAIT 30 SEC RETRY START	Engine Crank Timeout	Engine crank attempt longer than 15 seconds above 50° F or longer than 30 seconds below 32° F.	FAULT
CPR CODE 4 OUT OF FUEL	Out of Fuel	Fuel level in tank below usable limit.	FAULT
CPR CODE 10 ENG SPEED RESPONSE	Engine Speed Response	Engine target idle speed not met within 10 seconds after loading compressor.	ALERT
CPR CODE 11 A/A/S ATTEMPT EXCEEDED	AutoStart Attempts Exceeded	Compressor not started after 3 crank attempts.	ALERT
CPR CODE 12 FUEL LEVEL LOW	Low Fuel Level	Fuel level in tank approaching empty.	ALERT
CPR CODE 16 HIGH ENGINE TEMP	High Engine Temperature	Engine coolant temperature greater than 226° F (Engine derate begins)	FAULT
CPR CODE 17 HIGH ENGINE TEMP	High Engine Temperature (Shutdown)	Engine coolant temperature greater than 231° F (Engine Shutdown)	FAULT
CPR CODE 18 LOW OIL PRESSURE	Low Oil Pressure	Low engine oil pressure	FAULT
CPR CODE 19 HIGH FUEL TEMP	High Fuel Temperature	Engine fuel temperature greater than 180° (Engine derate)	ALERT
CPR CODE 25 UNINTENDED LOAD	Unintended Load	Air pressure in regulation system exceeded limit prior to loading.	FAULT
CPR CODE 26 LOAD INHIBIT DELAY	Load Inhibit Delay	The operator has attempted to load the machine before the warm up timer has expired.	ALERT
CPR CODE 28	Incorrect Engine ECU Calibration	Engine ECU has a different calibration than what is expected (Engine will not crank).	ALERT

CPR CODE 29 ENGINE SHUTDOWN UNKNOWN	Engine Shutdown Unknown	Engine stopped without an engine diagnostic code.	FAULT
CPR CODE 30 HIGH AIREND TEMP	High Airend Discharge Temperature	Airend discharge temperature greater than or equal to 251° F.	FAULT
CPR CODE 32 AIREND DISC TEMP SENSOR	Airend Discharge Temperature Sensor	Airend discharge temperature sensor reading out of range.	FAULT
CPR CODE 33 SEP TANK PRES SENSOR	Separator Tank Pressure Sensor	Separator Tank Pressure Sensor reading out of range.	FAULT
CPR CODE 34 HIGH PRES AT START	High Separator Tank Pressure At Start	Separator Tank Pressure greater than 20 psi at crank attempt.	FAULT
CPR CODE 35 HIGH SEPT TANK PRES	High Separator Tank Presssure	Air Pressure in the Separator Tank exceeded limit.	FAULT
CPR CODE 36 SAFETY VALVE OPEN	Safety Valve Open	Safety relief valve on separator tank opened.	FAULT
CPR CODE 38 AIR FILTERS RESTRICTED	Intake Air Filters Restricted	Intake filters restricting air flow.	ALERT
CPR CODE 39 LOW SYSTEM VOLTAGE	Low System Voltage/Alternator Not Charging	Electrical system voltage below 13.5VDC.	ALERT
CPR CODE 42 FUEL LEVEL SENSOR	Fuel Level Sensor	Fuel Level Sensor reading out of range.	ALERT
CPR CODE 43 LOW SEP TANK PRES	Low Separator Tank Pressure	Separator tank pressure below 40 psi after compressor is loaded.	FAULT
CPR CODE 44 HIGH IQ FILTERS RESTR	High IQ Filter Restriction	IQ filters restricting air flow.	ALERT
CPR CODE 50 HIGH SEP TANK TEMP	High Separator Tank Temperature	Separator tank temperature greater than or equal to 251° F.	FAULT
CPR CODE 51 COMPRESSOR ID INVALID	Compressor ID Invalid	The Compressor Controller and Mini-Port Display do not have a valid compressor ID.	FAULT

CPR CODE 52 IQ FILTERS RESTRICTED	IQ Filters Restricted	IQ filters restricted past usable level.	FAULT
CPR CODE 53 SEP TANK TEMP SENSOR	Separator Tank Temperature Sensor	Separator tank temperature sensor reading out of range.	FAULT
CPR CODE 54 REG SYSTEM PRES SENSOR	Regulation System Pressure Sensor	Regulation system pressure sensor reading out of range.	FAULT
CPR CODE 55 E E STOP ACTIVATED	Emergency Stop Activated	Emergency Stop Button has been activated.	FAULT
CPR CODE 56 LOW START PRESSURE	Low Pressure During Warmup	The machine is detecting a low system pressure before the machine is loaded.	FAULT
CPR CODE 58 AMBIENT TEMP SENSOR	Ambient Temperature Sensor	Ambient temperature sensor reading out of range.	ALERT
CPR CODE 61 IQ FILTER PRES ERROR	IQ Filter Pressure Sensor	IQ Differential Pressure Sensor reading out of range.	ALERT
CPR CODE 63 AMBIENT TEMP SENSOR	Ambient Temperature Sensor	Ambient temperature sensor reading out of range.	ALERT
CPR CODE 71 ENG ECM COMMS	Engine ECM Communication	Communication between Compressor Controller and engine ECM not functional.	FAULT
CPR CODE 73 AUTOSTART CTRL COMMS	AutoStart Controller Communication	Communication between Compressor Controller and engine ECM not functional.	ALERT
CPR CODE 75 IQ TCU CTRL COMMS	IQ TCU Controller Communication	Communication between Compressor Controller and engine IQ TCU controller not functional.	ALERT
CPR CODE 75 IQ TCU CTRL COMMS	IQ TCU Controller Communication	Communication between Compressor Controller and engine IQ TCU controller not functional.	ALERT
CPR CODE 76 CPR CTRL COMMS	Compressor Controller Communication	Communication between Compressor Controller with Micro-Port Display not functional.	ALERT



Warranty



Doosan Portable Power General Warranty Information

The following charts summarize the general warranty information for Doosan Portable Power machines and the applicable warranty for your specific machine is available at:

<http://www.doosanportablepower.com/en/aftermarket/warranty>

Compressors

Products	Package	Airend	Extended Coverage	
			Package	Airend
Portable Compressors	1 yr / 2000 hrs Parts & Labor	2 yrs / 4000 hrs Parts & Labor	N/A	*5 yrs / 10000 hrs limited optional warranty

Electric Compressors

Products	Package	Airend	Extended Coverage	
			Package	Airend
Electric Compressors	1 yr / 2000 hrs Parts & Labor	2 yrs / 4000 hrs Parts & Labor	N/A	*5 yrs / 10000 hrs limited optional warranty

* The limited optional warranty is automatically available when the initial user registers their machine prior to expiration of the standard warranty and can demonstrate that the following conditions have been met during the warranty period:

1. All maintenance is completed at prescribed intervals using only genuine Doosan parts, fluids, and filters.
2. The original airend/engine is returned assembled and unopened.
3. The starter, alternator, fuel system components, all electrical components, and all NHP models are excluded from this optional warranty.
4. To register please click the following link: <http://go.doosanportablepower.com/extendedwarranty>, or contact your local Doosan Portable Power dealer.

Generators

Products	Package	Generator	Extended Coverage	
			Package	Generator
Portable Generators 10 KVA thru 570 KVA	1 yr / 2000 hrs Parts & Labor	2 yrs / 4000 hrs Parts & Labor	N/A	N/A

Lighting

Products	Package	Generator	LED Fixture and Driver
Lighting Systems	2 yrs / 2000 hrs Parts & Labor	2 yrs / 4000 hrs Parts & Labor	5 yrs / Parts & Labor
Balloon Light	1 yr Parts & Labor	6 months Parts & Labor	N/A

Light Compaction

Products	Package	Extended Coverage	
Light Compaction Equipment Plate & Drum Compactors, Rammers	1 yr Parts & Labor	N/A	N/A

DOOSAN

Truck Mounted Equipment

Products	Package	Airend	Extended Coverage	
			Package	Airend
Truck Mounted Equipment	1 yr / 2000 hrs Parts & Labor	2 yrs / 4000 hrs Parts & Labor	N/A	*5 yrs / 10000 hrs limited optional warranty

Compressor Modules

Products	Package	Airend	Extended Coverage	
			Package	Airend
Compressor Modules	1 yr / 2000 hrs Parts & Labor	2 yrs / 4000 hrs Parts & Labor	N/A	*5 yrs / 10000 hrs limited optional warranty

* The limited optional warranty is automatically available when the initial user registers their machine prior to expiration of the standard warranty and can demonstrate that the following conditions have been met during the warranty period:

1. All maintenance is completed at prescribed intervals using only genuine Doosan parts, fluids, and filters.
2. The original airend/engine is returned assembled and unopened.
3. The starter, alternator, fuel system components, all electrical components, and all NHP models are excluded from this optional warranty.
4. To register please click the following link register please click the following link:
<http://go.doosanportablepower.com/extendedwarranty>, or contact your local Doosan Portable Power dealer.

Replacement Parts

Parts	Months	Hours
Doosan	6	No Limit

This parts warranty applies for replacement parts only. If a replaced part fails within six months of installation, a Parts Claim may be submitted. Invoice is required for purchased part that failed.

ALL WARRANTIES PROVIDED BY DOOSAN PORTABLE POWER HEREIN ARE EXCLUSIVE AND IN LIEU OF ALL OTHER WARRANTIES, EXPRESS OR IMPLIED (EXCEPT THAT OF TITLE), AND THERE ARE NO IMPLIED WARRANTIES OF MERCHANTABILITY OR FITNESS FOR A PARTICULAR PURPOSE. IN NO EVENT SHALL DOOSAN PORTABLE POWER OR ITS AUTHORIZED DEALERS BE LIABLE FOR ANY SPECIAL, INCIDENTAL, INDIRECT, OR CONSEQUENTIAL DAMAGES WHATSOEVER, WHETHER BASED ON CONTRACT, WARRANTY, TORT, NEGLIGENCE, STRICT LIABILITY, STATUTE OR OTHERWISE, EVEN IF DOOSAN PORTABLE POWER OR ITS AUTHORIZED DEALERS HAVE BEEN ADVISED OF THE POSSIBILITY OF SUCH DAMAGES. THE TOTAL LIABILITY OF DOOSAN PORTABLE POWER AND ITS AUTHORIZED DEALERS WITH RESPECT TO THE PRODUCT FURNISHED SHALL NOT EXCEED THE PURCHASE PRICE OF THE PRODUCT.

It is the selling dealer's responsibility to register each product sold on Doosan's Warranty Website by entering current customer information and warranty start date. Any changes in ownership thereafter may be submitted to Doosan Portable Power by completing an Equipment Transfer Request. This form may be found at the Doosan website under Aftermarket > Warranty

<http://www.doosanportablepower.com/en/aftermarket/warranty>



**DOOSAN INFRACORE
FEDERAL & CALIFORNIA EMISSION CONTROL SYSTEMS
LIMITED WARRANTY for NON-ROAD ENGINES (CI)**

OWNER'S WARRANTY RIGHTS AND OBLIGATIONS

The U.S. Environmental Protection Agency (EPA), the California Air Resources Board (ARB), and Doosan Infracore are pleased to explain the Federal and California Emission Control System Warranty on your 2017MY to 2019MY non-road engine. DOOSAN INFRACORE has designed, built and equipped the engine so as to conform at the time of sale with all applicable regulations of the EPA and of the California ARB. In California, new heavy-duty off-road engines must be designed, built and equipped to meet the State's stringent anti-smog standards.

Doosan Infracore must warrant to the initial owner, and each subsequent owner, the emission control system on your engine for the periods of time listed below provided there has been no abuse, neglect, improper maintenance or unapproved modifications of your engine. Your emission control system may include those parts listed below:

- | | |
|--|---|
| <p>1. Fuel Metering System
Fuel Supply Pump (HP Pump), Injector, Common Rail, Glow Plug</p> <p>2. Air-Induction System
Intake Manifold, Turbocharger System</p> <p>3. Exhaust Gas Recirculation (EGR) System
EGR Valve, EGR Cooler</p> <p>4. Catalyst or Thermal Reactor System
Diesel Oxidation Catalyst (DOC), Exhaust Manifold</p> <p>5. Positive Crankcase Ventilation (PCV) System
PCV Valve</p> | <p>6. Electronic Control System
ECU, Cam / Crank Sensor, Coolant Temperature Sensor, MAF Sensor, MAP Sensor (Manifold Pressure Sensor), Inlet Boost Temperature Sensor, Fuel Temperature Sensor, Common Rail Pressure Sensor</p> <p>7. Miscellaneous Items Used In Above Systems Temperature and time sensitive valve and switches Solenoids and wiring harnesses, hoses, clamps, fittings and tubing, sealing gasket, pulleys, belts and idlers, Emission control information labels</p> |
|--|---|

When a warrantable condition exists, DPP will repair your heavy-duty off-road engine at no cost to you, including diagnosis, parts, and labor.

MANUFACTURER'S WARRANTY COVERAGE

The 2017MY to 2019MY heavy-duty off-road engines are warranted for **five years or 3,000 hours** of operation, whichever occurs first. If any emission-related part on your engine is defective, the part will be repaired or replaced by DPP. The warranty period shall begin on the date the machine is delivered to the first retail customer.

OWNER'S WARRANTY RESPONSIBILITIES

As a Doosan off-road engine owner, you are responsible for the performance of the **required maintenance listed in the Operation and Maintenance Manual**. DPP recommends that you retain all receipts covering maintenance on your engine, but DPP cannot deny warranty solely for the lack of receipts or for your failure to ensure the performance of all scheduled maintenance.

However, you should be aware that Doosan may deny you warranty coverage if your heavy-duty off-road engine or a part has failed due to abuse, neglect, improper maintenance or unapproved modifications.

Your engine is designed to operate on **Ultra Low Sulfur Diesel Fuel Only**. Use of any other fuel may result in your engine no longer operating in compliance with the EPA's emissions requirements.

You are responsible for initiating the warranty process. The EPA and California ARB suggest that you present your machine to your Doosan Portable Power dealer as soon as a problem exists. The warranty repairs should be completed by the dealer as expeditiously as possible.

If you have any questions regarding your warranty rights and responsibilities, please contact your nearest authorized Doosan Portable Power dealer: go to <http://www.doosanportablepower.com> and click on Our Company > Our Dealer Network, call 1-800-633-5206, or mail:

Attn: Technical Services Dept.
Doosan Portable Power
1293 Glenway Drive
Statesville, NC 28625

Corp. R&D Div.

1 of 1



Doosan Infracore Portable Power
1293 Glenway Drive
Statesville, N.C. 28625
DoosanPortablePower.com

Doosan Infracore
Portable Power