

QUICK REFERENCE GUIDE

MODELS - TCWHI80S-AS & TCWHI99S-AS

WARNING

Read the Installation Manual carefully and be sure that your water heater has been properly assembled BEFORE reviewing these instructions. Failure to follow the instructions included in the Installation Manual exactly as written could result in fire, explosion, electrical shock, or other situation that could result in property damage, serious personal injury, or death. Installation and service must be performed by a qualified plumber, licensed gas fitter, or a professional technician in accordance with all local codes. Improper installation and/or operation by an unqualified person WILL VOID the warranty. This water heater must be installed in accordance with all local codes. In the absence of local codes, follow ANSI Z223.1 / NFPA 54 or CAN/CSA B149.1, Natural Gas and Propane Installation Code, as applicable.

CHAPTER 1 - BEFORE INSTALLATION

1. This water heater requires the use of direct vent type pipe as specified by American Standard Water Heaters. DO NOT use materials that are not specified for use with this water heater.
2. Always install water heater exhaust vent / intake pipe terminations 12 inches above maximum expected snow accumulation levels.
3. Check the water heater rating plate to ensure the water heater is set to operate on the gas supplied and that the gas supply line is sized to the Btu/h required for this water heater. (Rating plate shown by example only).
4. The power supply required is 120VAC at 60Hz. Failure to provide the correct power supply could result in electric shock or fire.

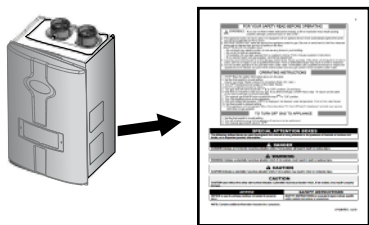

CHAPTER 2 - CONSIDER INSTALLATION SITE

Locate the water heater in a site where leakage from the water heater or connections will not result in damage to the site adjacent to the water heater. When such locations cannot be avoided, it is recommended that a suitable drain pan, adequately drained, be installed under the water heater. Install the water heater in a location that allows for proper clearances to combustible and noncombustible construction. Consult the rating plate for proper clearances.

Minimum Clearances		
Installation Clearances from Non Combustibles / Combustibles		Recommended Service and Proper Operation Clearances
Top	9 in. (228.6 mm)	9 in. (228.6 mm)
Back	5/8 in. (15.9 mm)	5/8 in. (15.9 mm)
Front	6 in. (152.4 mm)	24 in. (609.6 mm) or more (Front of Water heater) (A combustible door or removable panel is acceptable front clearance.)
Right Side	3 in. (76.2 mm)	3 in. (76.2 mm)
Left Side		
Bottom	12 in. (304.8 mm)	12 in. (304.8 mm)

CHAPTER 3 - INSTALLATION

A. INCLUDED ACCESSORIES

	Installation / User's Information Manuals / Quick Reference Guide
	Condensate Hose
	Anchors and Wall Mounting Bracket
	Spare Parts Kit (O-Rings and Gaskets)
	Vent Screens

B. MOUNTING ON THE WALL

- Please refer to the installation manual before mounting the water heater.
- Ensure the mounting location can support the weight of the filled water heater.
- Drill four (4) holes with a 15/32 drill bit in the locations on the wall bracket.
- Mount the wall bracket level on the wall with four (4) anchor bolts.
- Align the grooves on the back of the water heater with the tongue on the wall mounting bracket.
- Remove the four screws on the water heater front cover. Remove the front cover.

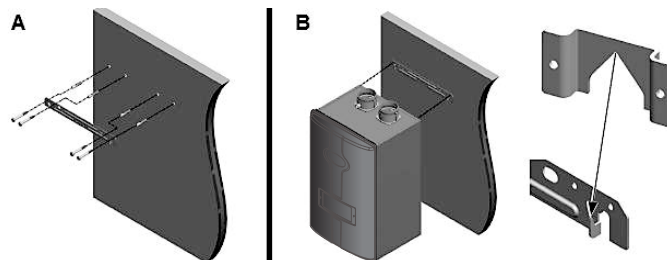

C. GAS PIPING

The gas connection fitting on the water heater is 3/4" female NPT. The supply line must be sized for the maximum output of the water heater model being installed. If there are additional gas appliances connected to the same supply line, size the supply line according to the COMBINED total maximum BTUH draw for the appliances as if they were operating at the same time.

DO NOT operate the water heater until all connections have been completed and the heat exchanger is filled with water.

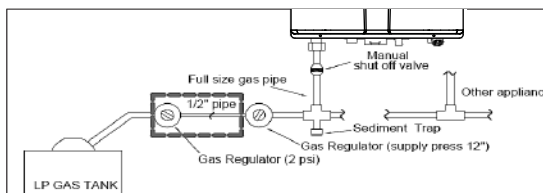
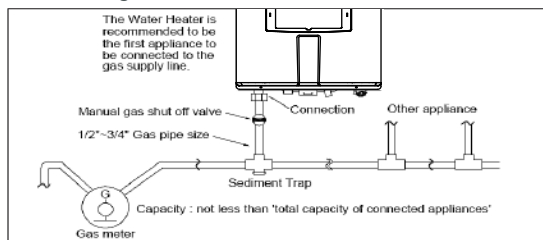

D. WATER PIPING

Ensure pipe material is suitable to meet local codes and standards. The pipe must be clean and without blemish. DO NOT apply torch heat within **12" of the bottom connections of the water heater**

The pipe size used for the supply of heated water should be the same size used for the water return pipe. The correct size of the hot water supply pipe should be 3/4" diameter. Install tankless isolation valves to avoid future service.

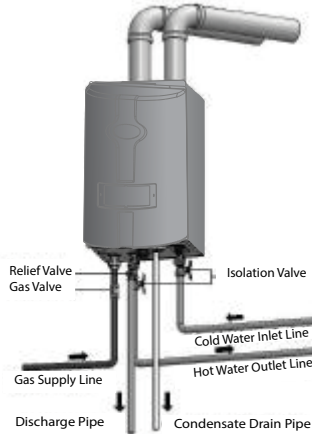

G. POWER CONNECTIONS & DIP SWITCH

I. Power Connections

WARNING

Ensure that all electrical connections and wiring are installed in accordance with all local codes. In the absence of local codes, follow the National Electrical Code, NFPA 70, and/or CSA C22.1 Electrical Code-Part I in Canada. For your safety, turn off the electrical power supply at the service entrance panel before making any electrical connections to avoid possible electrical shock hazard. Failure to do so may result in property damage, severe personal injury, or death.
NOTE: DO NOT disconnect the power supply during normal water heater operation.

II. Dip Switch

Dip Switch		Off	On
1 - 3	Not used	Not used	
4	Not used	Not used	
5	Gas Type	LP	NG
6	High Fire	Normal	High Fire
7	Low Fire	Normal	Low Fire

CHAPTER 4 – AFTER INSTALLATION

A. OPEN THE WATER AND GAS LINE VALVES

B. ADJUST CONTROL PANEL ON WATER HEATER FRONT COVER

Ensure water heater is powered ON. Press & hold the button for standby mode. Current 'DHW' set-point will display and flash. Concurrently, the caution mark 'H' will display. Current 'DHW' set-point can be changed by rotating the dial. After changing the temperature, press the Center Button to save settings.

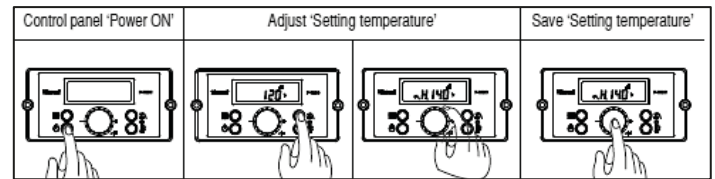

C. MEASURING INLET GAS PRESSURE

NOTE: Refer to Installation Manual when adjusting gas pressure.

- The water heater and its individual shutoff valve must be disconnected from the gas supply during pressure testing of the system at test pressures greater than 1/2 psi (3.5 kPa).
- The water heater must be isolated from the gas supply by closing the manual shutoff valve during pressure testing of the gas supply at test pressures equal to or greater than 1/2 psi (3.5 kPa).

The minimum and maximum inlet gas line pressures must meet the requirements shown below:

	LP GAS	NATURAL GAS
Minimum Pressure	3.5" WC	Minimum Pressure 3.5" WC
Maximum Pressure	14" WC	Maximum Pressure 14" WC

NOTICE

Do not attempt to ignite/operate water heater until all connections have been completed and the heat exchange is filled with water. Doing so will damage the water heater and void the warranty.

CHAPTER 5 – FINAL CHECK

- Check Installation completely.
- Check for leaks along Gas Pipes & Installation.
- Check Exhaust Vent and Intake Pipe Installation for leaks. Ensure all vent pipes are properly supported.
- Check Condensate Drain Installation.
- Ensure DIP switches are properly installed.
- Check the Electrical Supply Power connections are correct.
- Check Burner Flame for proper operation.

NOTICE: American Standard Water Heaters reserves the right to make product changes or updates without notice and will not be held liable for typographical errors in literature.

NOTE TO CONSUMER: PLEASE KEEP ALL INSTRUCTIONS FOR FUTURE REFERENCE.

E. CONDENSATE DRAIN CONNECTION

Condensate must be drained in accordance with all local codes & regulations. Follow local codes regarding the disposal of condensate & drainage. Diagram left; (1) Condensate to neutralizer, (2) to floor drains, (3) to bathtub, (4) to condensate pump. Use only corrosion resistant materials for the condensate drain lines, such as 1/2" PVC, CPVC, Polypropylene, or the included plastic hose. If a neutralizer is installed, periodic replacement of the limestone (or neutralizing agent) will be required. The rate of depletion of limestone varies upon usage of the water heater. During the first year of operation, check the neutralizer every few months for depletion.

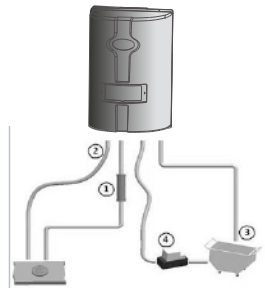

F. VENTING

Acceptable Vent Lengths (PVC, CPVC, PP)

Models	2" Combustion Air / Vent Pipe		3" Combustion Air / Vent pipe	
	Max	Maximum Number of Elbows	Max	Maximum Number of Elbows
TCWHI80S-AS	15'	2	100'	6
TCWHI99S-AS	(4.5M)		(30M)	

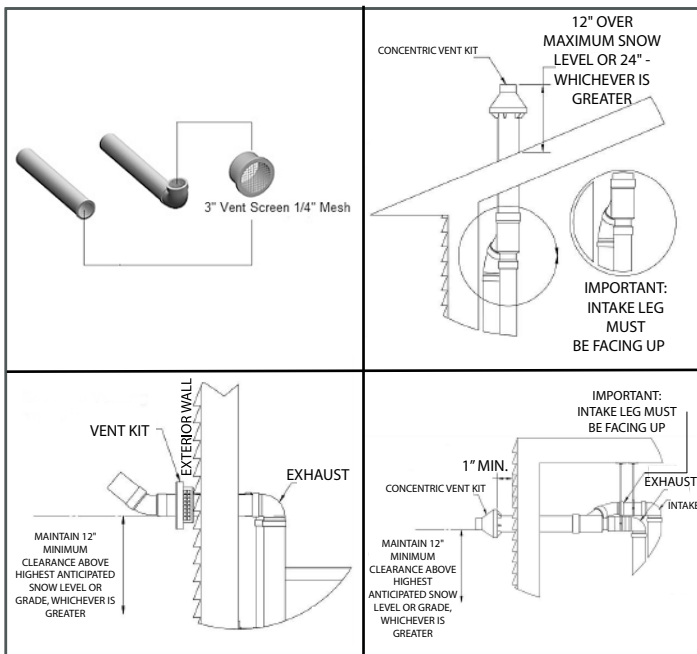

NOTE: Ensure all vents are properly supported.