

Shark[®]

Rotator[®] Upright Vacuum

NV500 Series

OWNER'S GUIDE



IMPORTANT SAFETY INSTRUCTIONS

FOR HOUSEHOLD USE ONLY • PLEASE READ CAREFULLY BEFORE USE

If the plug does not fit fully into the outlet, reverse the plug. If it still does not fit, contact a qualified electrician. DO NOT force into outlet or try to modify to fit.

⚠ WARNING

To reduce the risk of fire, electric shock, injury, or property damage:

GENERAL WARNINGS

When using an electrical appliance, basic precautions should always be followed, including the following:

1. Your vacuum cleaner may consist of a motorized nozzle, wand, hose, and/or vacuum pod. This device contains electrical connections, electrical wiring, and moving parts that potentially present risk to the user.
2. Use only identical replacement parts.
3. Carefully observe and follow the instructions provided below to avoid improper use of the appliance. **DO NOT** use the vacuum for any purpose other than those described in this manual.
4. Before use, carefully inspect all parts for any damage. **DO NOT** use if any parts are damaged.
5. The use of an extension cord is **NOT** recommended.
6. This vacuum cleaner contains no serviceable parts.

USE WARNINGS

7. This appliance can be used by persons with reduced physical, sensory or mental capabilities or lack of experience and knowledge if they have been given supervision or instruction concerning use of the appliance in a safe way and understand the hazards involved. Cleaning and user maintenance shall not be made by children.

8. Keep the appliance and its cord out of reach of children. **DO NOT** allow the appliance to be used by children. **DO NOT** allow to be used as a toy. Close supervision is necessary when used near children.
9. Always turn off the vacuum cleaner before connecting or disconnecting any motorized nozzles or other accessories.
10. **DO NOT** handle plug or vacuum cleaner with wet hands.
11. **DO NOT** use without filters in place.
12. Only use Shark® branded filters and accessories. Failure to do so will also void the warranty.
13. **DO NOT** damage the power cord:
 - a) **DO NOT** pull or carry vacuum cleaner by the cord or use the cord as a handle.
 - b) **DO NOT** unplug by pulling on cord. Grasp the plug, not the cord.
 - c) **DO NOT** run the vacuum cleaner over the power cord, close a door on the cord, pull the cord around sharp corners, or leave the cord near heated surfaces.
14. **DO NOT** put any objects into nozzle or accessory openings. **DO NOT** use with any opening blocked; keep free of dust, lint, hair, and anything that may reduce airflow.
15. **DO NOT** use if nozzle or accessory airflow is restricted. If the air paths or the motorized floor nozzle become blocked, turn the vacuum cleaner off and unplug from electrical outlet. Remove all obstructions before you plug in and turn on the unit again.

16. Keep nozzle and all vacuum openings away from hair, face, fingers, uncovered feet, or loose clothing.
17. **DO NOT** use if vacuum cleaner is not working as it should, or has been dropped, damaged, left outdoors, or dropped into water.
18. Use extra care when cleaning on stairs.
19. **DO NOT** leave the vacuum cleaner unattended while plugged in.
20. When powered on, keep the vacuum cleaner moving over the carpet surface at all times to avoid damaging the carpet fibers.
21. **DO NOT** place vacuum cleaner on unstable surfaces such as chairs or tables.
22. Your Shark® vacuum may not be designed to stand up on its own. When taking a break from cleaning, you may need to lean it against furniture or a wall, or lay it flat on the floor. Using the vacuum for an application where the unit lacks stability may result in personal injury.
23. **DO NOT** use to pick up:
 - a) Liquids
 - b) Large objects
 - c) Hard or sharp objects (glass, nails, screws, or coins)
 - d) Large quantities of dust (drywall dust, fireplace ash, or embers). **DO NOT** use as an attachment to power tools for dust collection.
 - e) Smoking or burning objects (hot coals, cigarette butts, or matches)
 - f) Flammable or combustible materials (lighter fluid, gasoline, or kerosene)
 - g) Toxic materials (chlorine bleach, ammonia, or drain cleaner)
24. **DO NOT** use in the following areas:
 - a) Poorly lit areas
 - b) Wet or damp surfaces
 - c) Outdoor areas
 - d) Spaces that are enclosed and may contain explosive or toxic fumes or vapors (lighter fluid, gasoline, kerosene, paint, paint thinners, mothproofing substances, or flammable dust)
25. Turn off all controls before plugging in or unplugging the vacuum.
26. Unplug from electrical outlet when not in use and before any maintenance or cleaning.
27. Hand wash with water only. Washing with cleaning chemicals could damage the unit.
28. During cleaning or routine maintenance, **DO NOT** cut anything other than hair, fibers, or string wrapped around the brushroll.
29. Allow all filters to air-dry completely before replacing in the vacuum to prevent liquid from being drawn into electric parts.
30. Make sure the dust cup and all filters are in place after routine maintenance.
31. If provided, secure the power cord around the two cord hooks during storage.

To reduce the risk of electric shock, this appliance has a polarized plug (one blade is wider than the other). This plug will fit in a polarized outlet only one way. If the plug does not fit fully in the outlet, reverse the plug. If it still does not fit, contact a qualified electrician to install the proper outlet. Do not change the plug in any way.

SAVE THESE INSTRUCTIONS

ASSEMBLY

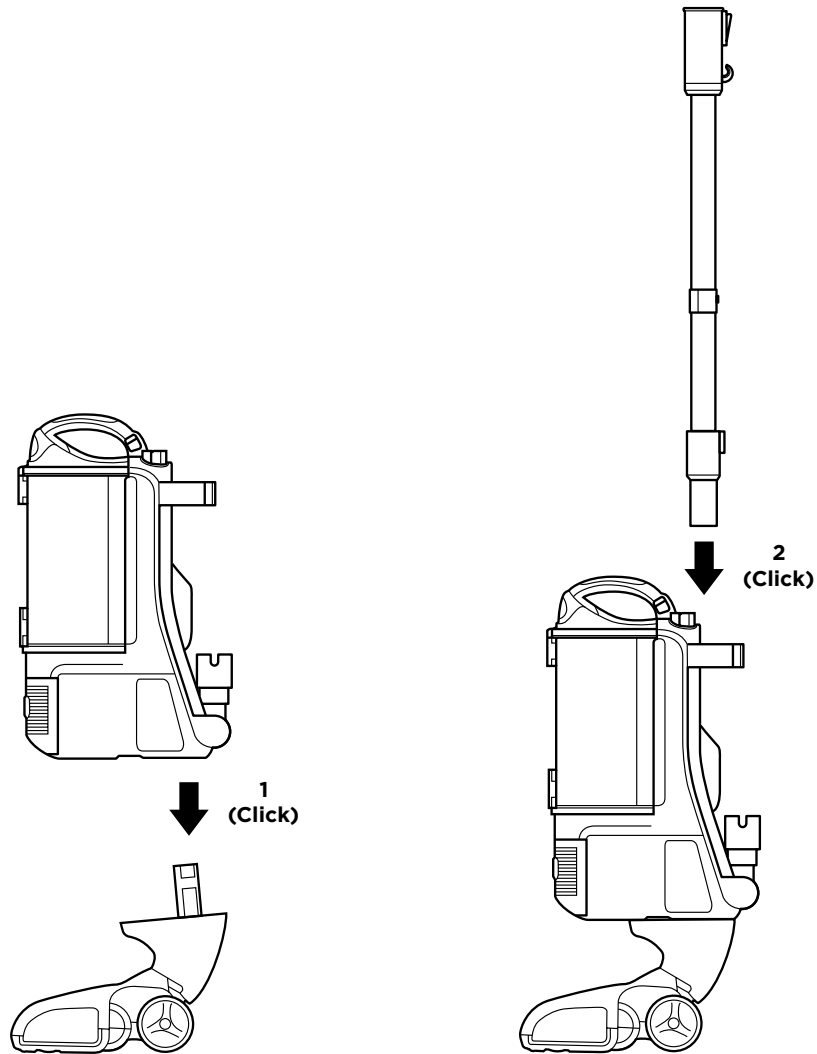

1. Place the **Pod** onto the **Floor Nozzle** post.
2. Insert the **Wand** into the pod.
3. Insert the **Handle** into the top of the wand.
4. Insert the **Hose** into the **Hose Holder** on the back of pod.
5. Insert the accessories into the **Accessory Clips** on the back of the pod.
6. Secure the hose by pressing the knob on the **Hose Clip** into the socket on the back of the pod.

For proper operation, ensure all parts are firmly clicked into place.

ASSEMBLY

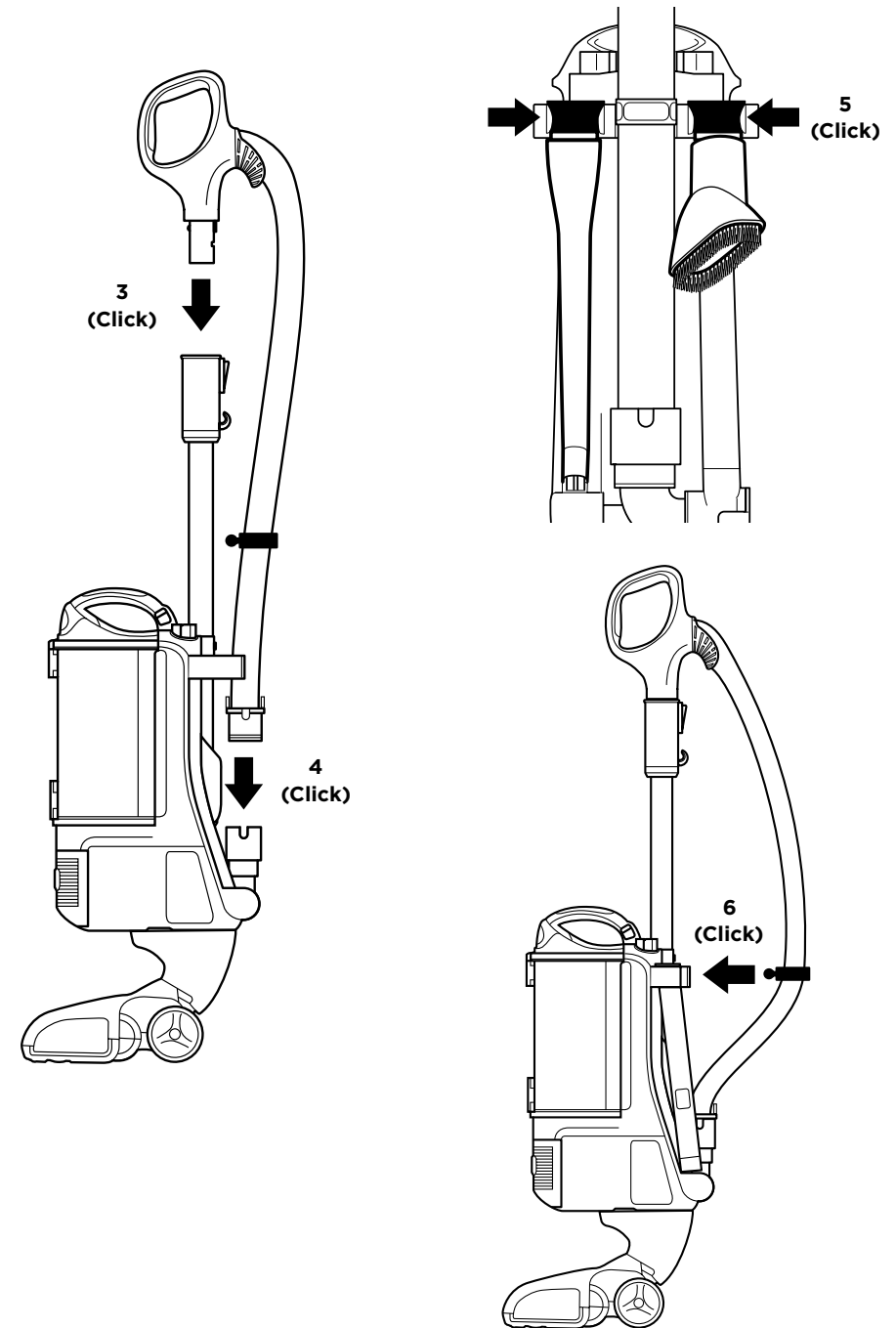

WHOLE-HOME CLEANING

POWER, BRUSHROLL, AND SUCTION CONTROL

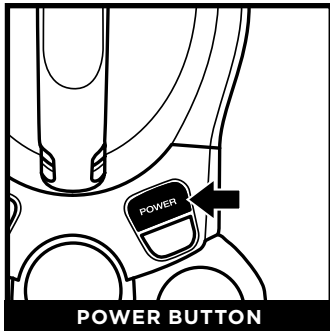

POWER BUTTON

Press the **POWER** button to clean hard-floor surfaces, area rugs, or above-floor areas. The brushroll will not spin in this mode.

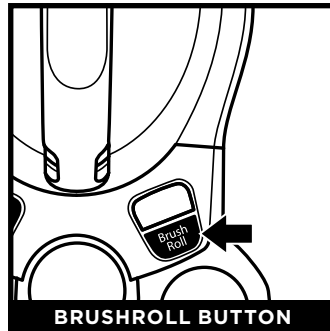

BRUSHROLL BUTTON

To clean carpets, press the power button and the **Brushroll** button. The brushroll will spin only when the handle is tilted back and the **Brushroll Indicator Light** is green.

SUCTION CONTROL

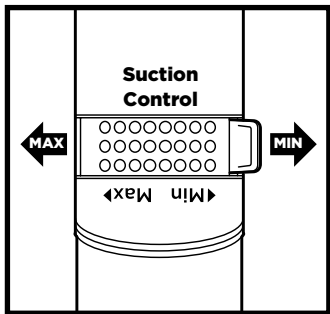

The **Suction Control** slider located on the top of the handle allows you to adjust the suction depending on the floor type.

MIN: to reduce suction and increase maneuverability on carpets.

MAX: to increase suction on bare floors.

BRUSHROLL INDICATOR LIGHT

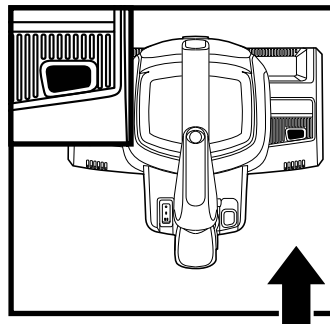

WHAT DOES THE BRUSHROLL INDICATOR LIGHT MEAN?

Solid Green: The brushroll is spinning and working as it should.

Solid Red: There is a jam in the brushroll area. Turn your vacuum off, unplug from the wall and remove any blockages in the nozzle.

Flashing Red: The motorized floor nozzle is overheating. Turn off the vacuum, unplug it, and remove any blockages. Let the vacuum cool down for at least 60 minutes before restarting. See Troubleshooting section for more information.

NOTE: For deep carpet cleaning per ASTM F608 (embedded dirt in carpets), set to **MAX** suction and press **Brushroll** button.

WHOLE-HOME CLEANING

CLEANING MODES

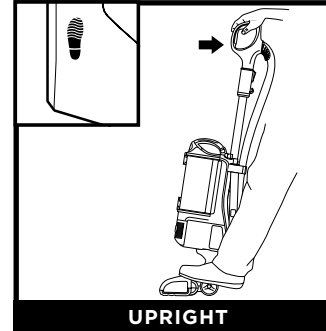

UPRIGHT

To engage brushroll, step on floor nozzle and tilt handle back.

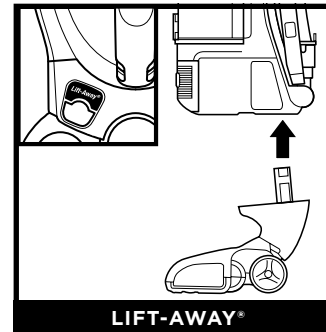

LIFT-AWAY*

Press the **Lift-Away** button to detach the pod from the floor nozzle.

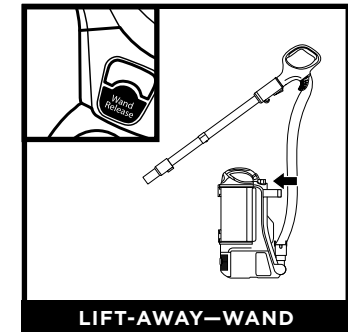

LIFT-AWAY-WAND

With pod removed, press the **Wand Release** button to detach the wand from the pod.

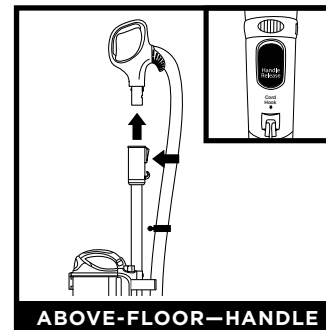

ABOVE-FLOOR-HANDLE

Press the **Handle Release** button to detach the handle from the wand.

NOTE: All accessories are compatible with both the wand and the handle.

EMPTYING THE DUST CUP

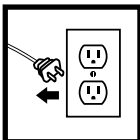

IMPORTANT: Unplug the power cord before performing any maintenance. Empty the dust cup each time you vacuum and periodically during cleaning, when debris in the dust cup reaches the MAX fill line.

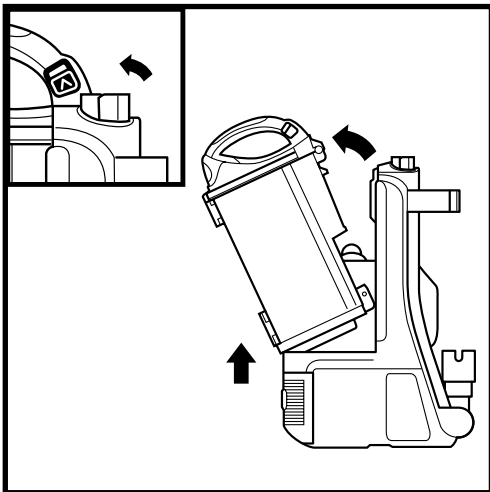

To remove **Dust Cup** from pod, pull up on release latches. Tilt dust cup, then lift to remove.

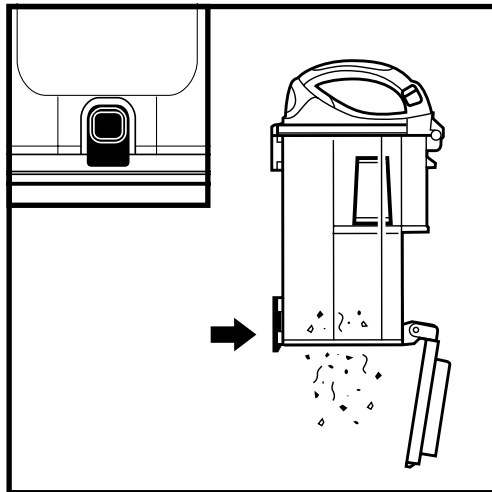

Hold dust cup over a trash bin and press **LOWER RELEASE** button to open bottom lid.

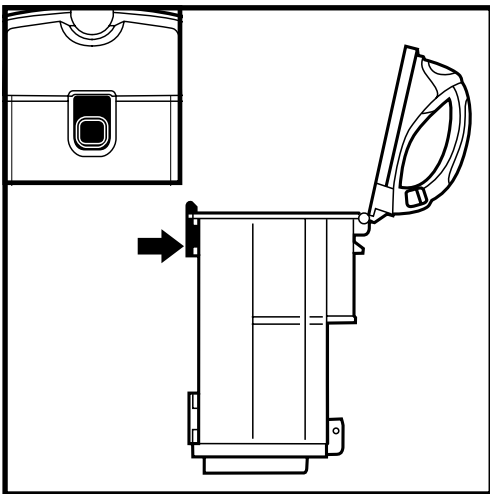

Press top dust-cup release latch to access dust screen and remove built-up debris as required.

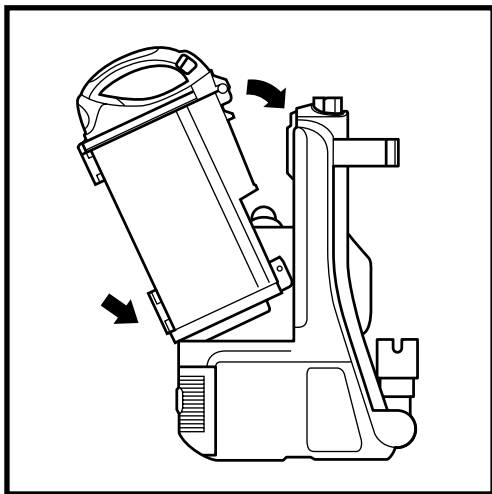

To reinstall, place bottom of dust cup into pod and then tilt it until it clicks into place.

CLEANING AND REPLACING THE FILTERS

CLEANING FILTERS

Regularly rinse and replace the filters to keep your vacuum's suction power optimal.

TO PREVENT DAMAGE FROM CLEANING CHEMICALS, RINSE FILTERS WITH COLD WATER ONLY. ALLOW ALL FILTERS TO AIR-DRY FOR AT LEAST 24 HOURS BEFORE REINSTALLING THEM TO PREVENT LIQUID FROM BEING DRAWN INTO ELECTRIC PARTS.

IMPORTANT: DO NOT use soap when cleaning the filters.

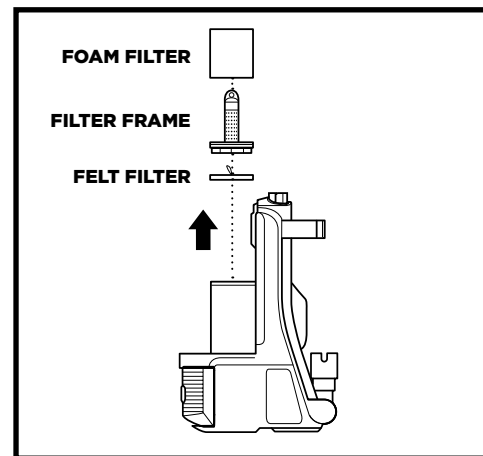

CLEAN PRE-MOTOR FILTERS EVERY 3 MONTHS

Remove **Dust Cup**, then lift out **Filters**.

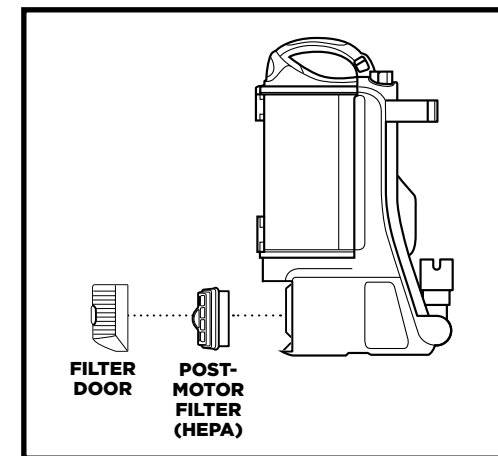

CLEAN POST-MOTOR FILTER EVERY YEAR

Press button at bottom of **Filter Door**. Tilt **Filter Door** and lift out. Remove **Post-Motor Filter (HEPA)**. To reinstall, insert filter into unit and replace the filter door.

NOTE: The pre-motor filters should be replaced every 2.5 years. The post-motor filter should be replaced every 3 years.

MAINTENANCE

CLEANING THE BRUSHROLL

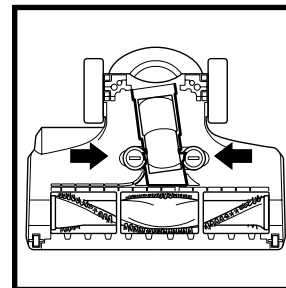

Using a coin, turn the locks to the unlock position and pull up to expose the airway. Remove any blockages.

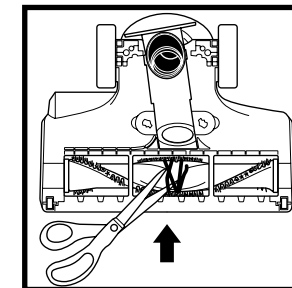

With scissors, carefully cut away any string, hair, or debris that may be wrapped around the brushroll.

CHECKING FOR BLOCKAGES

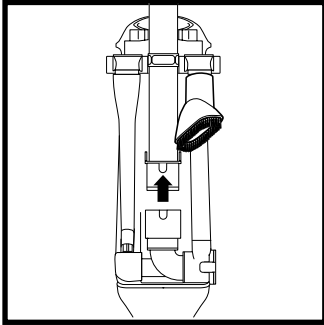

To remove the hose from the connector, squeeze both tabs and lift out the hose. Clear any blockages.

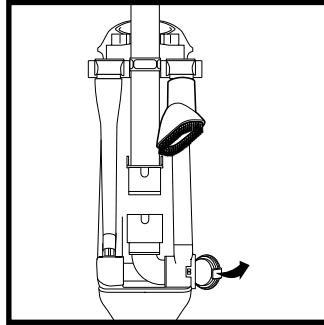

Open the clog access door on the side of the pod and remove any blockages.

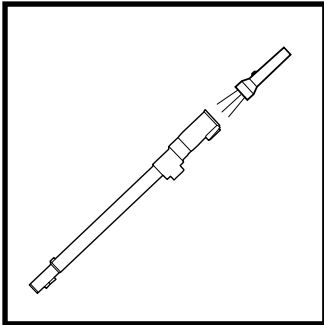

Detach the wand from the floor nozzle and the handle, and check both ends for blockages.

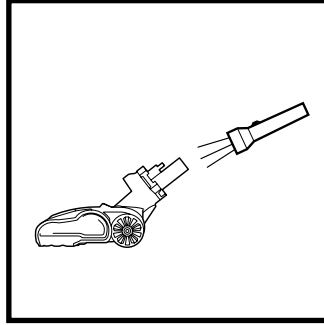

Detach the pod and wand from the floor nozzle, tilt the nozzle neck back, and check the opening for blockages.

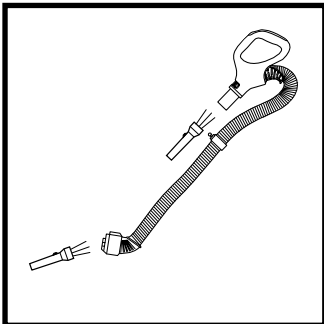

To remove the hose from the connector, squeeze both tabs and lift out the hose. Detach the handle from the top of the wand and check the hose and handle for blockages.

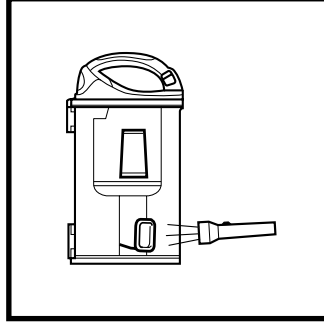

Detach the dust cup from the vacuum pod. Empty the dust cup, remove debris from the lint screen, and check for blockages.

COMPATIBLE ACCESSORIES

NOTE: Not all accessories come with all units. For a list of the accessories included with this model, see the top inside flap of the box. To order additional accessories, visit sharkaccessories.com.

To purchase additional accessories, go to sharkaccessories.com

A Crevice Tool

Clean in corners and other tight spaces or reach baseboards and ceilings with this slim crevice tool.

B Dusting Brush

This brush dusts and cleans delicate surfaces. Great for use on fans, blinds, lampshades, and keyboards.

C Wide Upholstery Tool

The wide cleaning path helps remove pet hair and large debris from mattresses, couches, curtains, lampshades, and other delicate fabrics.

D Pet Power Brush

The turbine brush loosens and removes pet hair and debris from carpets, and powerfully deep-cleans dander out of upholstery and other surfaces.

E Under-Appliance Wand

Clean under and behind hard-to-move appliances and furniture with this adjustable 36" tool. Flip the extension piece over to clean the underside of appliances.

F Home & Car Detail Kit

Deep-clean your car like a professional detailer, or clean hard-to-reach areas in your home. Micro-sized tools let you clean around delicate objects and access the tightest spaces like car vents and computer keyboards. Zipper pouch and instruction sheet included.

G Large Accessory Bag

This convenient accessory storage bag measures 32 cm x 70 cm and fits the Under-Appliance Wand. Smaller size available at sharkaccessories.com.

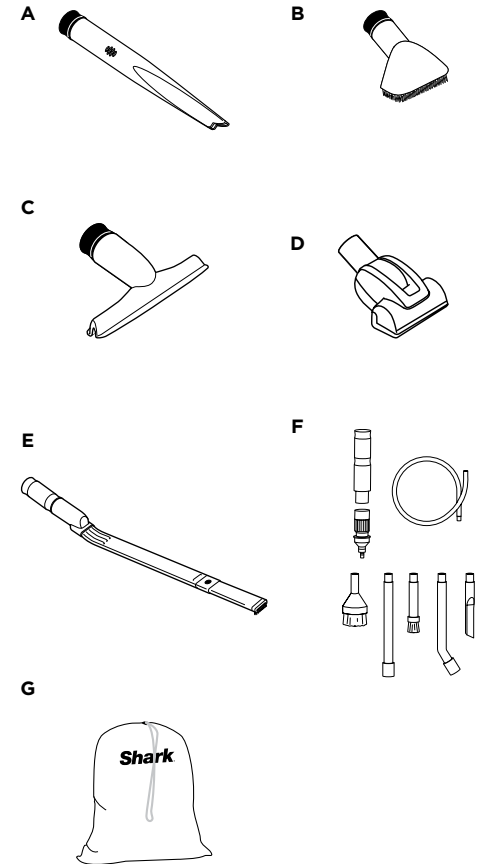

TROUBLESHOOTING

Vacuum is not picking up debris. No suction or light suction.

- Check filters to see if they need cleaning. Follow instructions for rinsing and air-drying the filters before reinserting in the vacuum.
- Dust cup may be full; empty dust cup.
- Check hose, hose connections, nozzle, wand, pod, and accessories for blockages. Clear any blockages found.
- If any string, hair, or carpet fibers are wrapped around the brushroll, remove the floor nozzle cover and carefully cut debris with scissors and remove from brushroll. See Cleaning the Brushroll section for more information.

Vacuum lifts area rugs.

- Make sure the power is turned on and the Brushroll button is turned off.
- Rotate suction control slider to MIN to reduce suction.
- Suction is powerful. Take care when vacuuming area rugs or rugs with delicately sewn edges.

Brushroll does not spin in carpet cleaning mode.

- If the Brushroll Indicator Light turns red, immediately turn off and unplug the vacuum. Remove pod from floor nozzle and clear any blockages. Reconnect nozzle, plug in vacuum, and turn on power.
- Make sure the Brushroll switch is selected and recline the handle, which will activate the brushroll.

Vacuum turns off on its own or indicator light flashes red.

If your vacuum overheats, the thermostat will automatically turn the suction motor off. Perform the following steps to restart:

1. Turn vacuum off and unplug it.
2. Empty dust cup and clean filters (see Emptying the Dust Cup and Cleaning and Replacing the Filters).
3. Check for blockages in hose, accessories, wand, nozzle, and inlet openings.
4. Allow unit to cool for a minimum of 60 minutes.
5. Plug in vacuum and turn it on.

Shark NINJA

FIVE (5) YEAR LIMITED WARRANTY

The Five (5) Year Limited Warranty applies to purchases made from authorized retailers of **SharkNinja Operating LLC**. Warranty coverage applies to the original owner and to the original product only and is not transferable.

SharkNinja warrants that the unit shall be free from defects in material and workmanship for a period of five (5) years from the date of purchase when it is used under normal household conditions and maintained according to the requirements outlined in the Owner's Guide, subject to the following conditions and exclusions:

What is covered by this warranty?

1. The original unit and/or non-wearable components deemed defective, in SharkNinja's sole discretion, will be repaired or replaced up to five (5) years from the original purchase date.
2. In the event a replacement unit is issued, the warranty coverage ends six (6) months following the receipt date of the replacement unit or the remainder of the existing warranty, whichever is later. SharkNinja reserves the right to replace the unit with one of equal or greater value.

What is not covered by this warranty?

1. Normal wear and tear of wearable parts (such as foam filters, HEPA filters, pads, etc.), which require regular maintenance and/or replacement to ensure the proper functioning of your unit, are not covered by this warranty. Replacement parts are available for purchase at sharkaccessories.com.
2. Any unit that has been tampered with or used for commercial purposes.
3. Damage caused by misuse (e.g., vacuuming up water or other liquids), abuse, negligent handling, failure to perform required maintenance (e.g., not cleaning the filters), or damage due to mishandling in transit.
4. Consequential and incidental damages.
5. Defects caused by repair persons not authorized by SharkNinja. These defects include damages caused in the process of shipping, altering, or repairing the SharkNinja product (or any of its parts) when the repair is performed by a repair person not authorized by SharkNinja.
6. Products purchased, used, or operated outside North America.

How to get service

If your appliance fails to operate properly while in use under normal household conditions within the warranty period, visit sharkclean.com/support for product care and maintenance self-help. Our Customer Service Specialists are also available at **1-800-798-7398** to assist with product support and warranty service options, including the possibility of upgrading to our VIP warranty service options for select product categories.

SharkNinja will cover the cost for the customer to send in the unit to us for repair or replacement. A fee of \$24.95 (subject to change) will be charged when SharkNinja ships the repaired or replacement unit.

How to initiate a warranty claim

You must call **1-800-798-7398** to initiate a warranty claim. You will need the receipt as proof of purchase. A Customer Service Specialist will provide you with return and packing instruction information.

How state law applies

This warranty gives you specific legal rights, and you also may have other rights that vary from state to state. Some states do not permit the exclusion or limitation of incidental or consequential damages, so the above may not apply to you.

REGISTER YOUR PURCHASE

 registryourshark.com

 1-800-798-7398

 Scan QR code using mobile device (NV501 models only)



RECORD THIS INFORMATION

Model Number: _____

Serial Number: _____

Date of Purchase: _____
(Keep receipt)

Store of Purchase: _____

TECHNICAL SPECIFICATIONS

Voltage: 120V- 60Hz

Watts: 1200W

 **TIP:** You can find the model number on the rating label located on the back of your unit.

 **TIP:** You can locate the date code on one of the prongs of the power cord plug.

PLEASE READ CAREFULLY AND KEEP FOR FUTURE REFERENCE.

This Owner's Guide is designed to help you get a complete understanding of your new Shark® Rotator® Upright Vacuum.

SharkNinja Operating LLC

US: Needham, MA 02494

CAN: Ville St-Laurent, QC H4S 1A7

sharkclean.com

Illustrations may differ from actual product. We are constantly striving to improve our products; therefore the specifications contained herein are subject to change without notice. For SharkNinja U.S. Patent information, visit sharkninja.com/uspatents

© 2020 SharkNinja Operating LLC. LIFT-AWAY, ROTATOR and SHARK are registered trademarks of SharkNinja Operating LLC.

PRINTED IN CHINA

NV500_Series_IB_E_REV_Mv6



@sharkcleaning