



# ASSEMBLY INSTRUCTIONS

## POWER LIFT® BASKETBALL SYSTEM



















Lifetime basketball systems are designed to be strong and durable. We strive to make assembly as easy as possible without compromising quality. If you get stuck, we have tools to help:

- **Prepare the Area**  
Before you start, you will need at least six 80-lb. bags of concrete mix. Before digging, call to locate any buried utility lines.
- **Recruit Friends and Family**  
Assembly should take 3 people about 3–4 hours to complete.

Save this instruction in the event that the manufacturer has to be contacted for replacement parts.

### TOOLS REQUIRED

 3/4" (19 mm) (2)	 1 1/16" (18 mm) (2)	 9/16" (14 mm) (2)	 1/2" (13 mm) (2)	 (1)
 (1)	 (1)	 (1)	 Cement 6-90-lb. bags	 (1)
 (1)	 (1)	 (1)	 (1)	 (1)
 (1)	 30" (762 mm) Rebar			

### TABLE OF CONTENTS

Icon Legend.....	2
Notices.....	3
Ground Preparation.....	4
Pole Assembly.....	9
Backboard to Rim Assembly.....	14
Backboard to Pole Assembly.....	20
Parts Identifier.....	i-iv
Handle Assembly.....	29
Final Assembly.....	36
Maintenance Instructions.....	43
Registration.....	43
Warning Sticker.....	44
Warranty.....	47

### NEED HELP? TALK TO US!

Lifetime's assembly experts offer quick responses and great customer service.

Call: 1-800-225-3865  
7:00 am–5:00 pm (Monday–Friday) MST  
and 9:00 am–1:00 pm Saturday MST

Web: [www.lifetime.com/instructions](http://www.lifetime.com/instructions)  
Live Chat: [www.lifetime.com/instructions](http://www.lifetime.com/instructions)

MODEL# AND PRODUCT ID (you will need both when contacting us)  
Model Number: 90698  
Product ID:



## ICON LEGEND



- Indicates special heed should be taken when reading.



- Indicates the parts to be used for a section.



- Indicates no parts required for a specific section.



- Indicates the hardware to be used for a section.



- Indicates no hardware required for a specific page.



- Indicates the tools to be used for a section.



- Indicates to use/not to use an electric drill for a specific step.

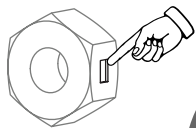

- Indicates the use of a Centerlock Nut. A Nut with this marking will require some effort to tighten. This hardware was designed with this feature in order to prevent loosening later.



## CONTACT US

- **Save this instruction in the event that the manufacturer has to be contacted for replacement parts.**

Call: **1-800-225-3865**  
 7:00 am–5:00 pm (Monday–Friday) MST  
 and 9:00 am–1:00 pm Saturday MST

**[www.lifetime.com/instructions](http://www.lifetime.com/instructions)**



## WARNINGS & NOTICES



### ***SAFETY INSTRUCTIONS***



**FAILURE TO FOLLOW THESE WARNINGS MAY RESULT IN SERIOUS INJURY OR PROPERTY DAMAGE AND WILL VOID WARRANTY.**

***Owner must ensure that all players know and follow these rules for safe operation of the system.***

To ensure safety, do not attempt to assemble this product without following the instructions carefully. Check entire box and inside all packing material for parts and/or additional instruction material. Before beginning assembly, read the instructions and identify parts using the hardware identifier and parts list in this document. Proper and complete assembly, use and supervision are essential for proper operation and to reduce the risk of accident or injury. A high probability of serious injury exists if this product is not installed, maintained, and operated properly.

- If using a ladder during assembly, use extreme caution.
- Two capable adults are recommended for this operation.
- Check base daily for leakage. Leaks will cause system to fall.
- Assemble the pole sections properly. Failure to do so could cause the pole sections to separate during play or transport.
- Minimum operational height is 6 ft 6 in (1.98m) to the bottom of the backboard.

***Most injuries are caused by misuse and/or not following instructions. Use caution when using this product.***

# 1

## GROUND PREPARATION



## HARDWARE REQUIRED



## PARTS REQUIRED

### Metal Parts

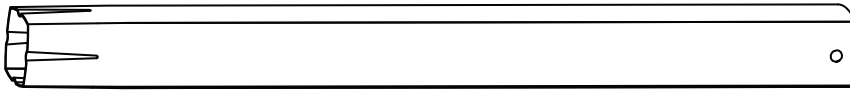

ALE (x1)

### Paper Parts

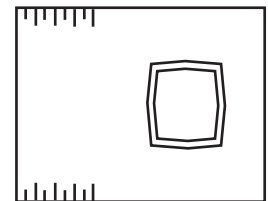

BGW (x1)



## TOOLS REQUIRED



(1)



Level



Cement Mix



(1)



30" Rebar



(1)

## ► SECTION 1 (CONTINUED)

### TOOLS AND HARDWARE REQUIRED



## 1.1

- Dig a round hole 24" deep and 21" in diameter. If you live in an area where frost heaves may pose a problem, consult your local building inspector to determine the proper hole depth. The edge of the hole should be flush with the edge of the playing surface.

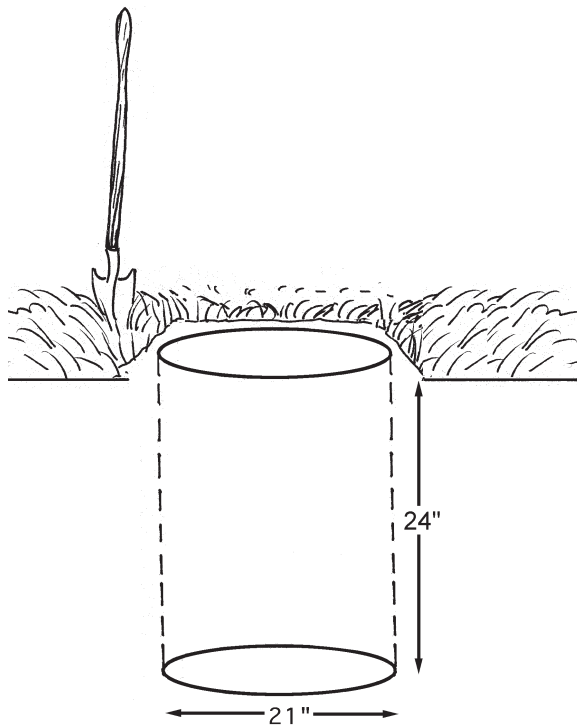

- *A Ground Sleeve is available as an alternative to cementing the Pole into the ground. Please contact Customer Service for more information.*

## ► SECTION 1 (CONTINUED)

TOOLS AND HARDWARE REQUIRED



(9 Bags, 80 lb each)



# 1.2

- Make a mark 16 inches from the dimpled end of the **Bottom Pole (ALE)** (do not scratch the powder coating). Slide the **Alignment Frame (BGW)** over the Bottom Pole.

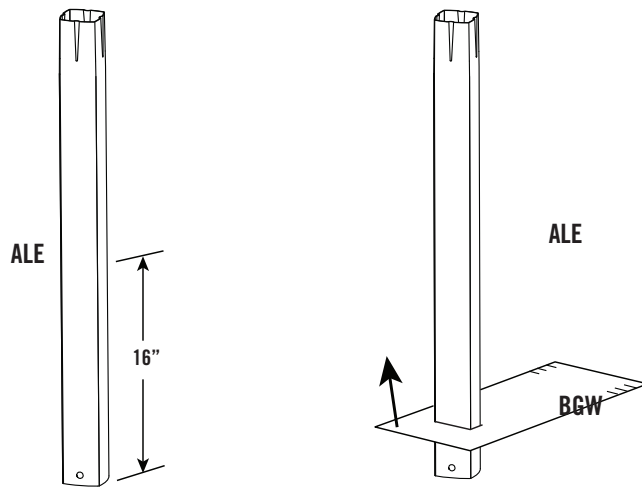

# 1.3

- Mix 5 1/2 bags of concrete. Save 1/2 bag of concrete mix to use later in the assembly. Pour the mixed concrete into the hole until it is filled to the level of the playing surface.



## SECTION 1 (CONTINUED)

### TOOLS AND HARDWARE REQUIRED



30" Rebar



# 1.4

- Slide the dimpled end of the **Bottom Pole (ALE)** into the cement up to the 16-inch mark. Position the pole next to the playing surface. For regulation courts, the **Alignment Frame (BGW)** should cross the playing surface at the middle of the scored measurements.

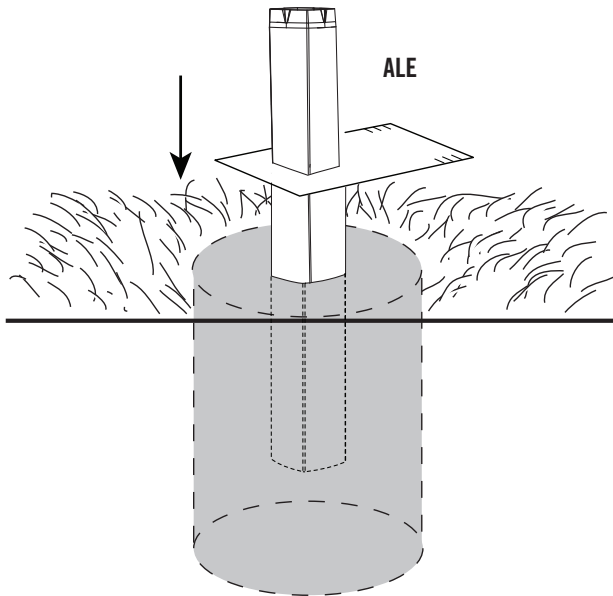

- If the pole is buried too deep or too shallow, the rim will not be at the correct height.

TOP VIEW

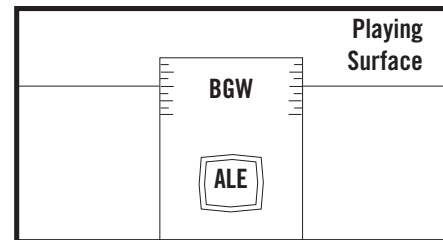

- Use a **Level** to make sure the **Bottom Pole** is standing vertical. Form the cement into a downward slope away from the pole to allow water runoff. Failure to do so may result in premature rusting of the Pole.

# 1.5

- Insert the 30" rebar (not included) inside the **Bottom Pole (ALE)** so it is about 15" from the top of the pole. **Check** the pole several times within the first hour to make sure that all sides are vertical and that the 16-inch mark remains level with the surface.

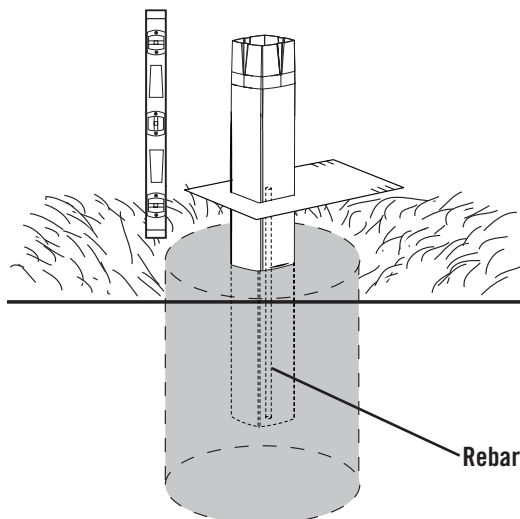

- Do not continue the assembly until the concrete has been allowed to set for 1-4 hours.

## ► SECTION 1 (CONTINUED)

TOOLS AND HARDWARE REQUIRED



# 1.6

- Mix the remaining 1/2 bag of concrete. Fill the **Bottom Pole (ALE)** with concrete until it reaches the top of the rebar (about 15" from the top of the pole). Tamp the concrete down in the Bottom Pole with a broom handle to remove air pockets. Clean all concrete off the outside of the pole. You may now remove the **Alignment Frame (BGW)**.

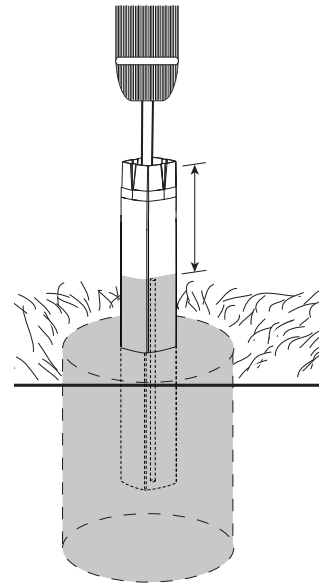
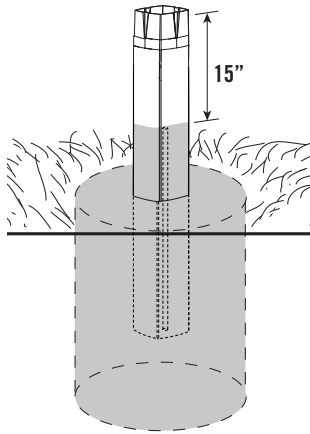
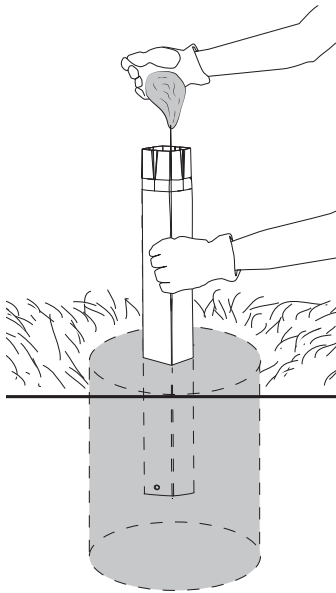

- **Stop assembly now. Do not continue the assembly until the concrete has been allowed to set for at least 72 hours (3 days). In humid climates or wet weather, allow more time for the concrete to cure. Do not proceed until the curing process is complete.**



# 2

## POLE ASSEMBLY



### HARDWARE REQUIRED

#### Hardware Bag



CMV (x2)

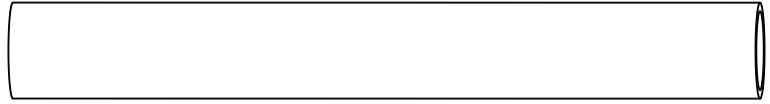

ANE (x2)

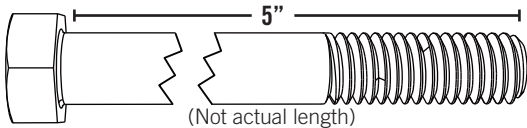

ANF (x2)

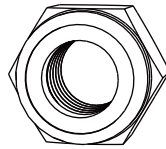

AAA (x2)

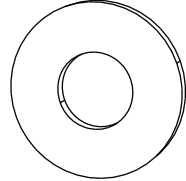

AAF (x2)



### PARTS REQUIRED

#### Metal Parts



ALF (x1)

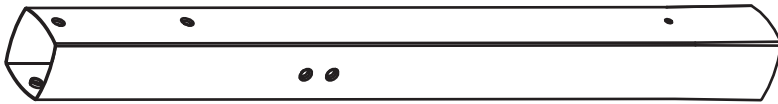

ALH (x1)

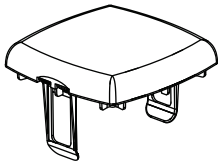

ALM (x1)

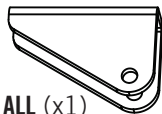

ALL (x1)



### TOOLS REQUIRED



## ► SECTION 2 (CONTINUED)

TOOLS AND HARDWARE REQUIRED

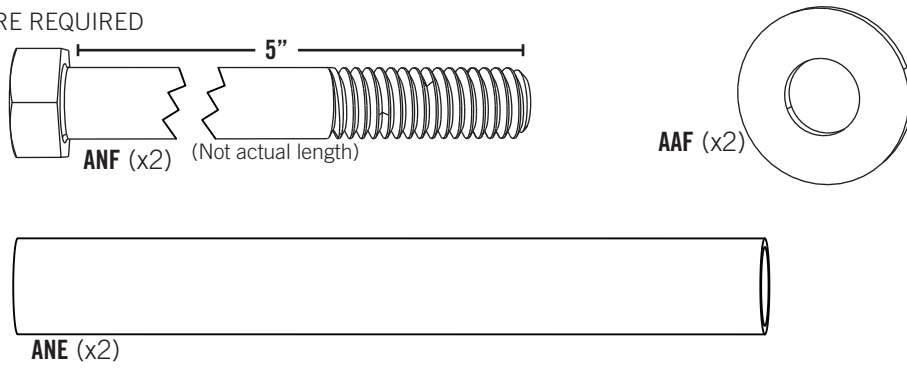

### 2.1

- After allowing the concrete to cure for at least 72 hours, insert the **Hex Bolts (ANF)** with the **Washers (AAF)** into the **Top Pole (ALH)** as shown. Then slide the **Spacers (ANE)** onto the Hex Bolts.

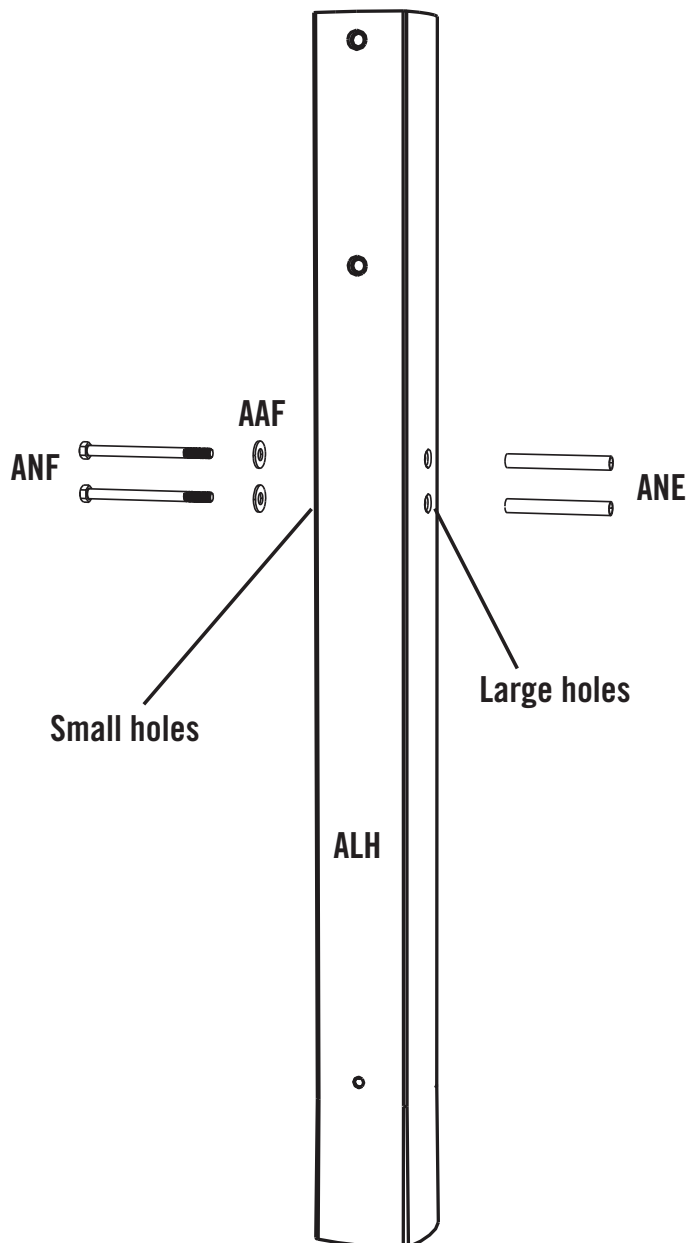

## ► SECTION 2 (CONTINUED)

TOOLS AND HARDWARE REQUIRED



9/16" (x2)

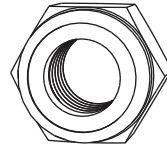

AAA (x2)

### 2.2

- Place the **Pole Bracket (ALL)** onto the **Hex Bolts (ANF)**, and attach it to the **Top Pole (ALH)** with the hardware shown.

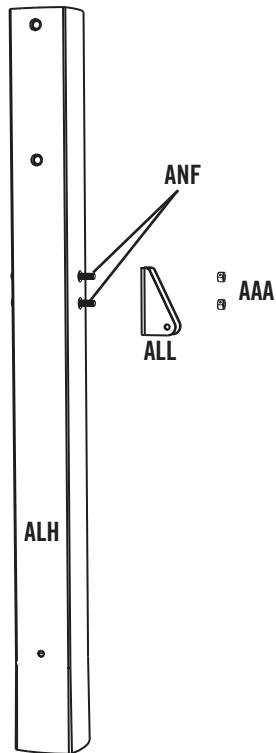

### 2.3

- Insert the slotted end of the **Middle Pole (ALF)** into the flared end of the **Top Pole (ALH)**. Make sure the poles are oriented as shown.

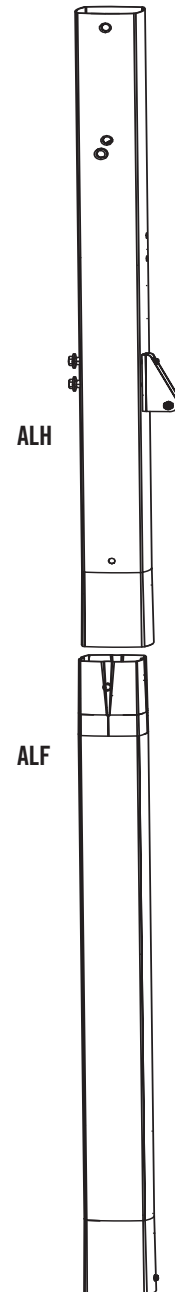

- *Make sure the Warning Sticker and the Pole Bracket face opposite directions.*

## ► SECTION 2 (CONTINUED)

TOOLS AND HARDWARE REQUIRED



### 2.4

- In order to seat the Poles, strike each end of the Pole very hard five to six times on a piece of scrap wood or cardboard. This must be done even if the Poles cover the slot before seating has occurred.



- *If the Top Pole (ALH) does not completely cover the slots on the Middle Pole (ALF) after seating, DO NOT COMPLETE ASSEMBLY. Call our Customer Service Department.*

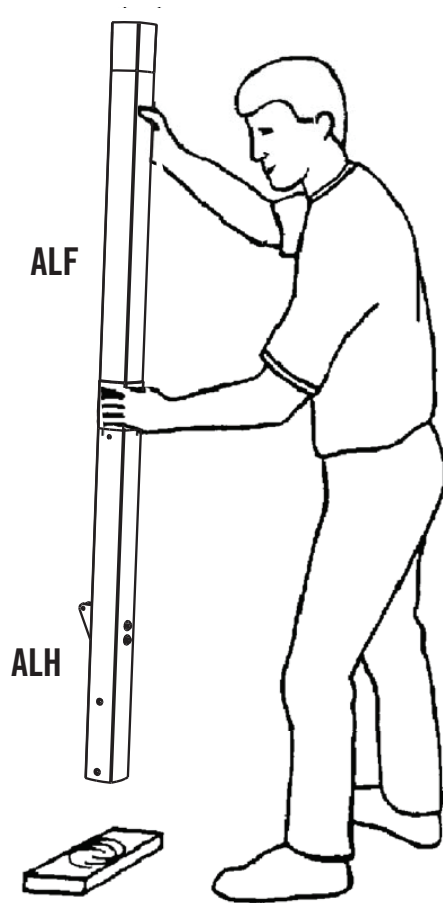

- *Do not hit your feet with the Pole sections, as serious injury could occur.*



### WARNING

The Poles must be seated together! Even if the Poles cover the slots before seating, they must be struck on a hard surface five to six times! Failure to seat the Poles correctly could allow the Poles to separate during use, which could lead to serious personal injuries or property damage.

## ► SECTION 2 (CONTINUED)

TOOLS AND HARDWARE REQUIRED

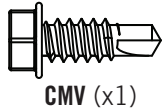
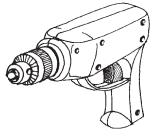

### 2.5

- After the Poles have been seated, measure up one inch from the bottom center of the **Top Pole (ALH)** and insert one **Self-Drilling Screw (CMV)** into the back of the Pole as shown. Then insert the **Pole Cap (ALM)** into the Top Pole. **Save the remaining Screw for use in Section 5.**

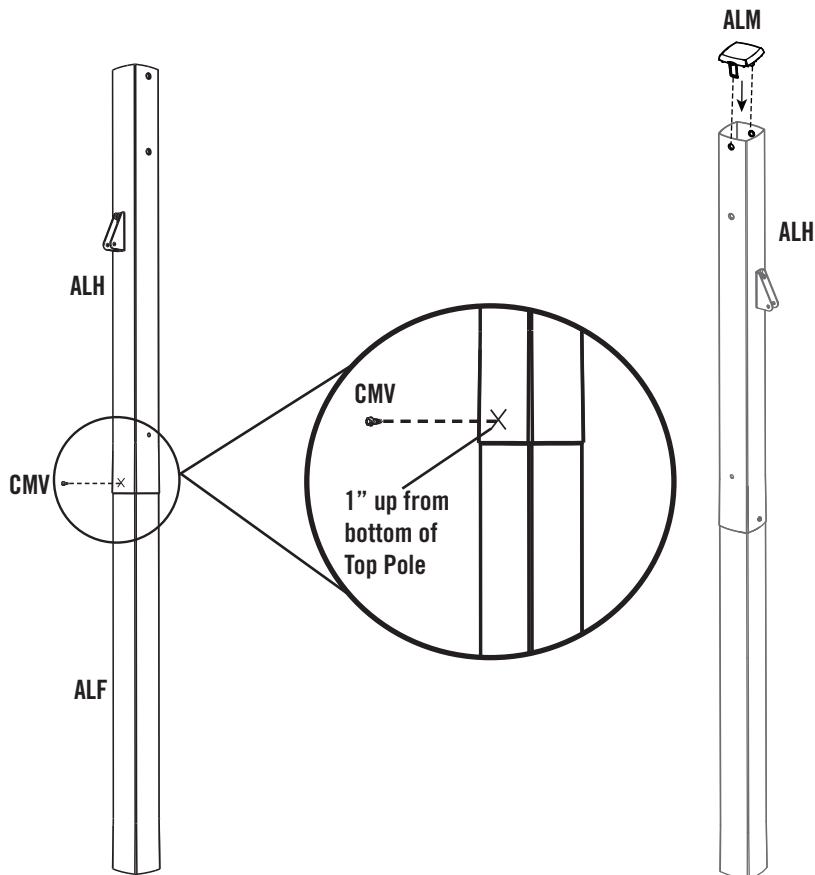

- *Chuck the Self-Tapping Screw directly into an Electric Drill for easy installation, or use a 3/8" Hex Driver.*

# 3

## BACKBOARD TO RIM ASSEMBLY



### HARDWARE REQUIRED

Hardware Bag

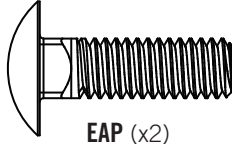
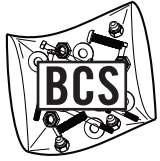

EAP (x2)

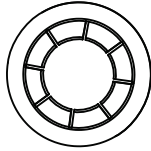

AAQ (x2)

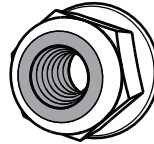

ABK (x4)

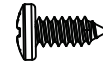

ADR (x4)

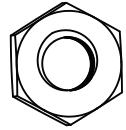

AAV (x2)

Hardware shown at 50% of Actual Size

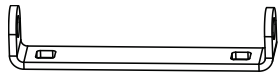

APY (x1)

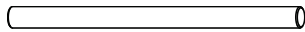

ABQ (x1)

Hardware shown at 25% of Actual Size

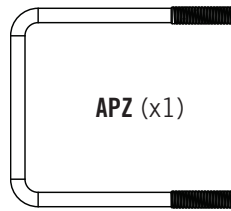

APZ (x1)



AOW (x1)



AJW (x2)



### PARTS REQUIRED

Metal Parts (Not shown at actual size)

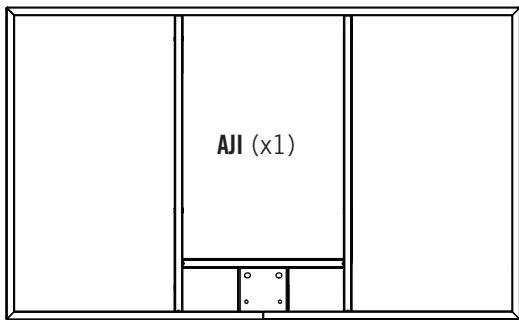

AJI (x1)

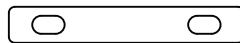

BGR (x1)

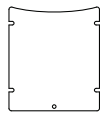

AMA (x1)

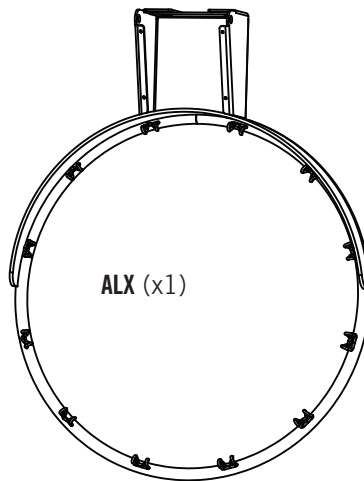

ALX (x1)

Platic Parts (Not shown at actual size)

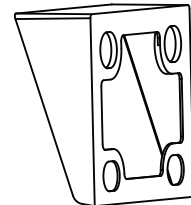

ALD (x1)



### TOOLS REQUIRED

1/2" (13 mm)



(2)

1/2" (13 mm)



(1)



(1)

## SECTION 3 (CONTINUED)

TOOLS AND HARDWARE REQUIRED

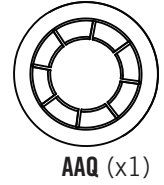
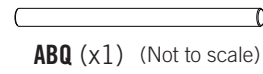
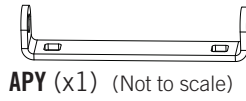
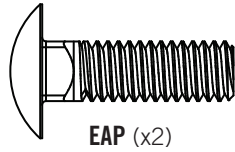
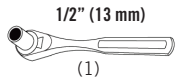

### 3.1

- Insert two **Carriage Bolts (EAP)** through the **Rim Pivot Bracket (APY)** as shown.

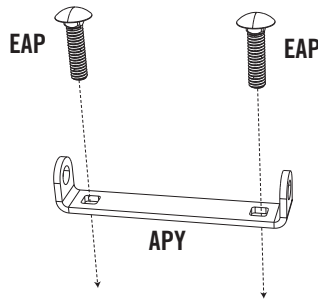

### 3.2

- Use the 1/2" socket head from the socket head wrench to press one **Push Nut (AAQ)** onto one end of the **Axle (ABQ)**.

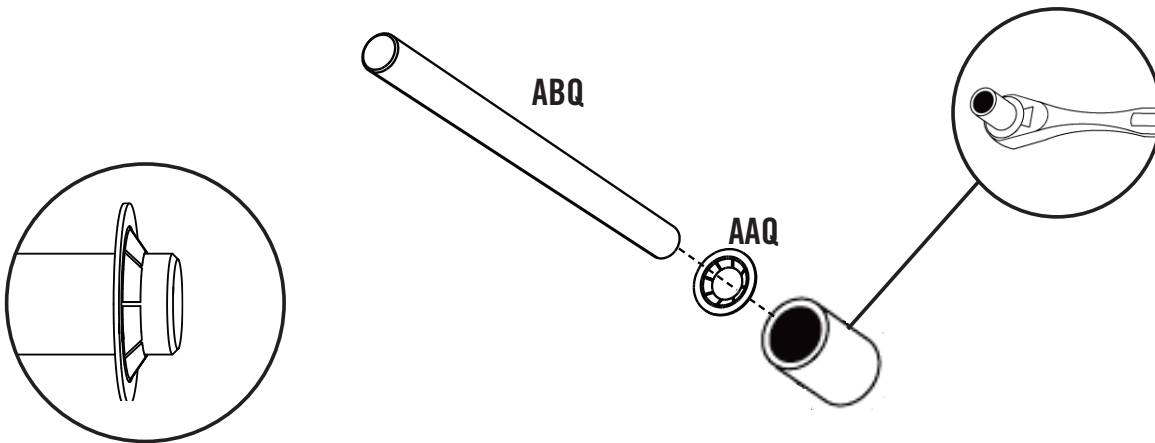

- *Note: The Push Nut should rest about 1/4" from the end of the Axle. If the Push Nut slips on too far, continue sliding it to the other end of the Axle to remove it and try again.*

## ► SECTION 3 (CONTINUED)

TOOLS AND HARDWARE REQUIRED

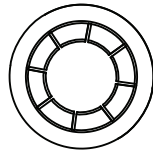
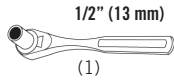

AAQ (x1)

### 3.3

- Slide the end of the **Axle (ABQ)** through the **Rim (ALX)** and the **Rim Pivot Bracket (APY)**. Press the **Push Nut (AAQ)** onto the end of the Axle. Use the 1/2" socket head to secure the Push Nut if needed.

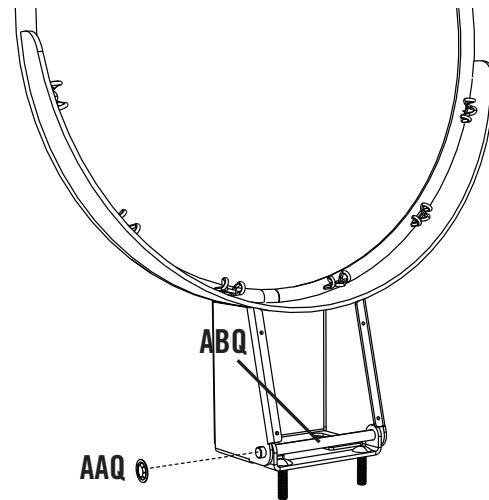
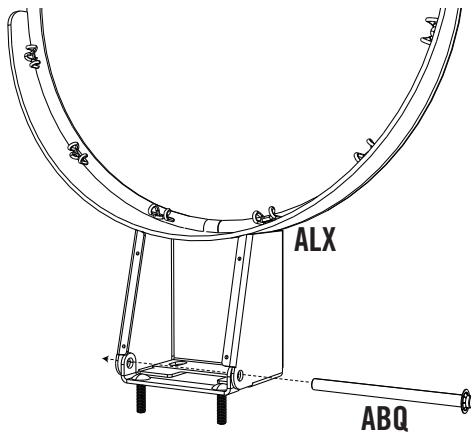
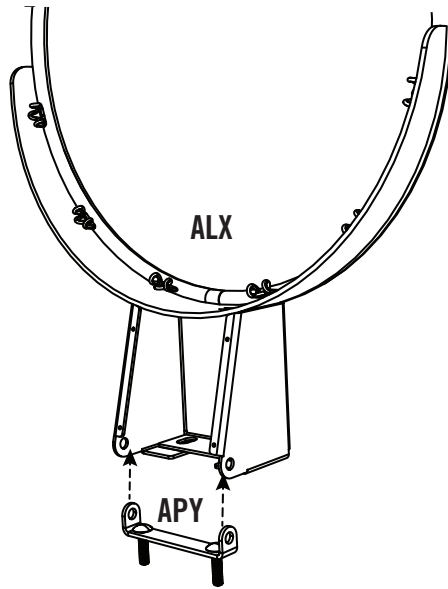



## ▶ SECTION 3 (CONTINUED)

TOOLS AND HARDWARE REQUIRED

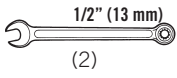

ABK (x2)

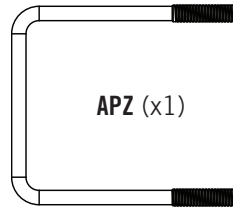

APZ (x1)

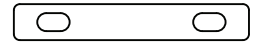

BGR (x1)

# 3.4

- Insert the U-Bolt (APZ) through the upper part of the opening on the backside of the Backboard (AJI). Connect the Rim (ALX) and Plastic Guard (ALD) to the Backboard (AJI) with the hardware as shown.

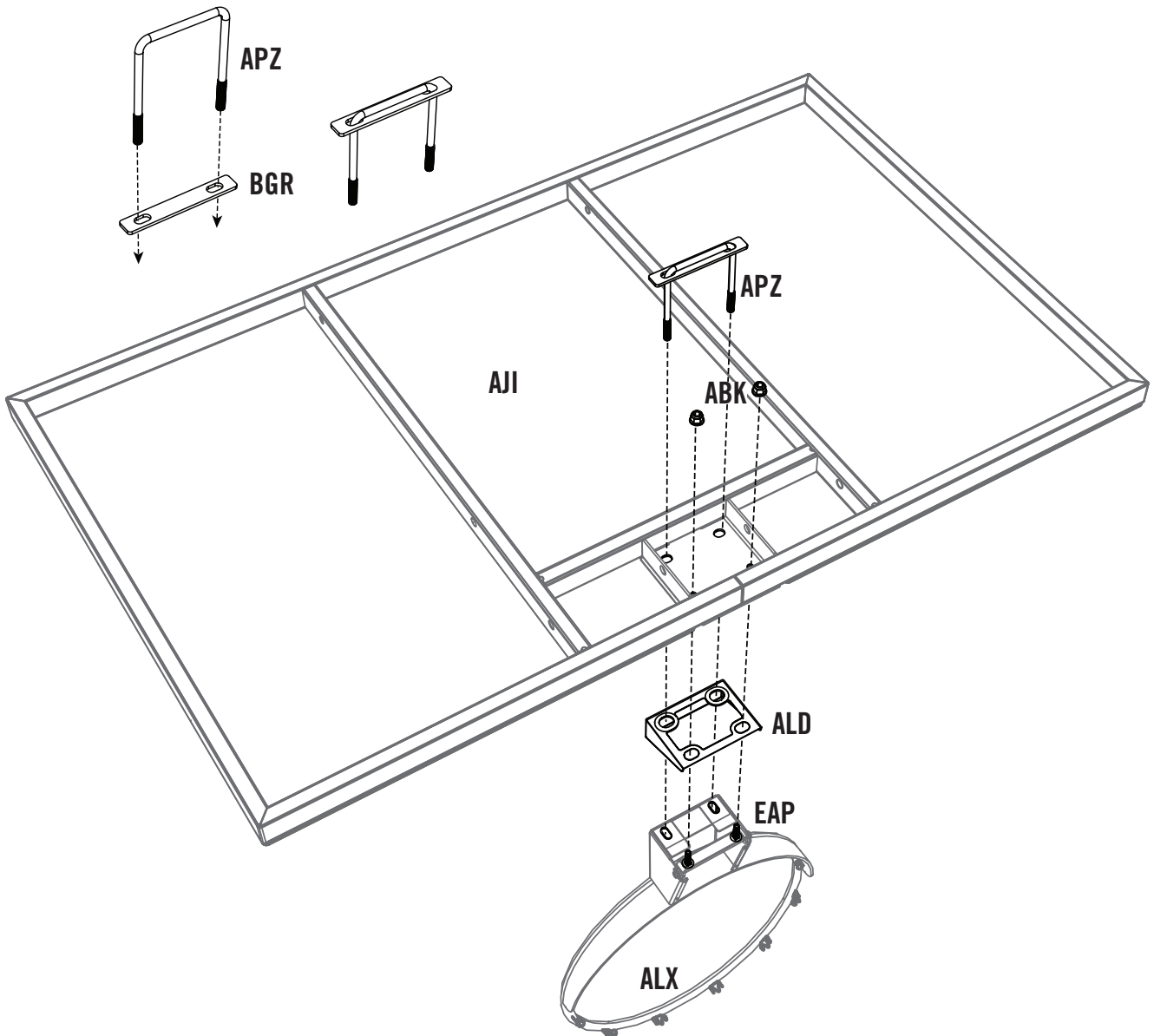

## ► SECTION 3 (CONTINUED)

TOOLS AND HARDWARE REQUIRED

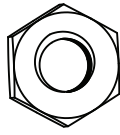
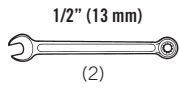

AAV (x2)



ABK (x2)



AOW (x1)



AJW (x2)

### 3.5

- Thread two **Jam Nuts (AAV)** all the way on to the **U-Bolt (APZ)**. Then slide the **Compression Springs (AJW)** onto the U-Bolt and place the **Spring Retainer Plate (AOW)** over the Compression Springs. Tighten the **Nylock Flange Nuts (ABK)** until the **Rim (ALX)** does not wobble to complete this step.

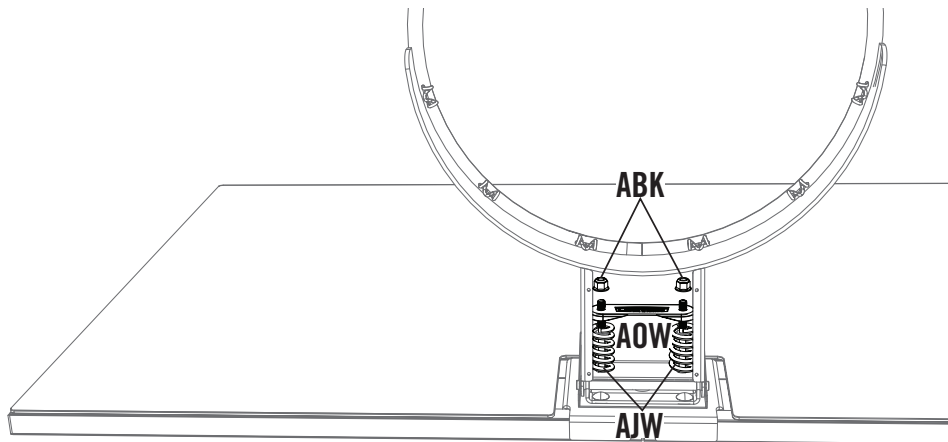
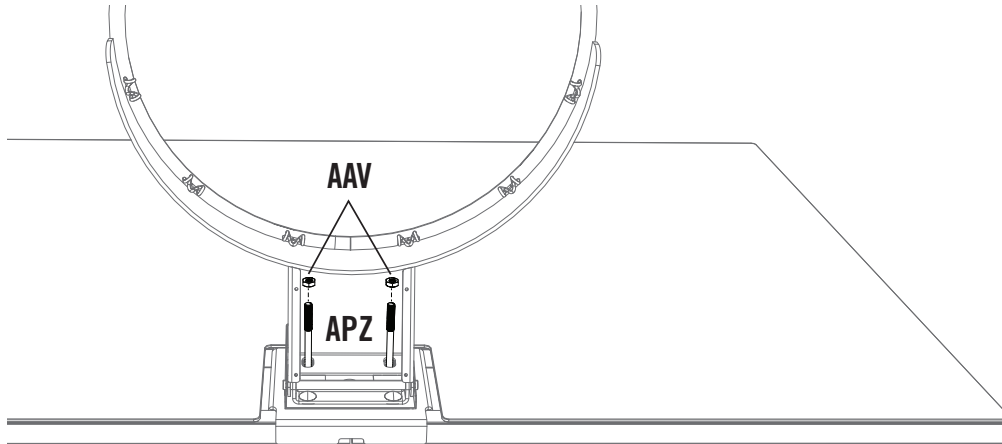

- **Note: DO NOT COMPLETELY TIGHTEN THE NYLOCK FLANGE NUTS IN THIS STEP!** Only tighten the nuts until the Rim does not wobble. Tightening the Nuts will adjust the Rim tension.

► SECTION 3 (CONTINUED)

TOOLS AND HARDWARE REQUIRED

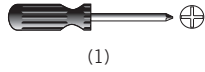

**3.6**

- Attach the **Rim Cover Plate (AMA)** to the **Rim (ALX)** with the hardware shown.

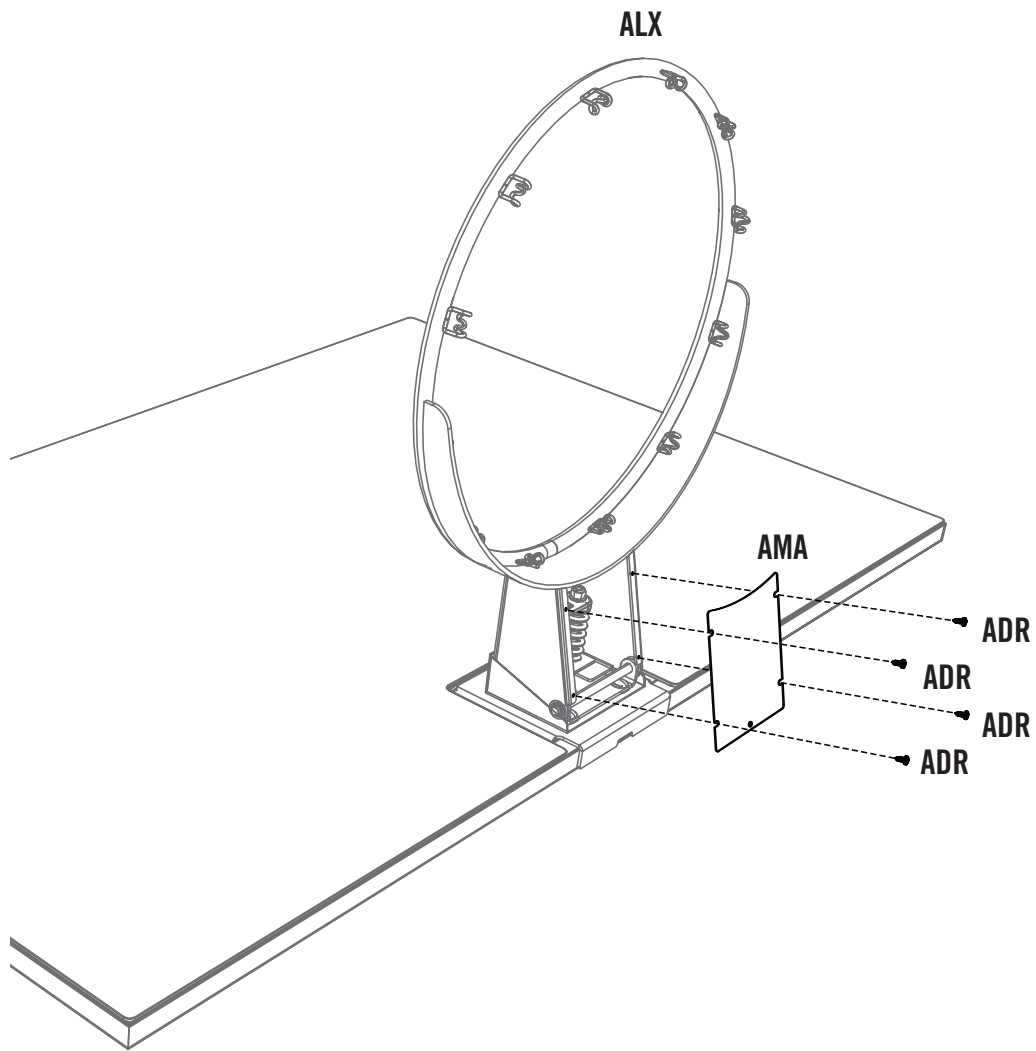

# 4

## BACKBOARD TO POLE ASSEMBLY



### HARDWARE REQUIRED

#### Hardware Bag

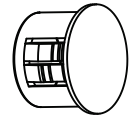
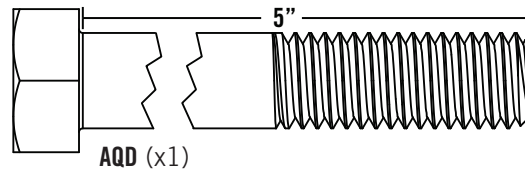
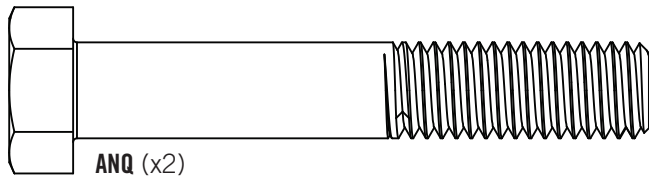
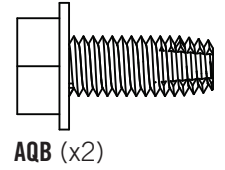
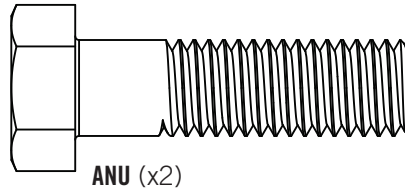
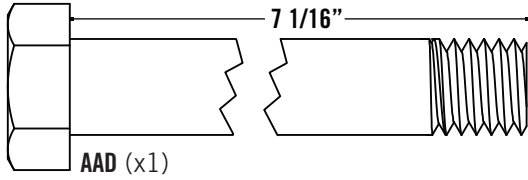

**ANS (x4) \***

\*Hardware Bag BCR may include extra Plastic Plugs (ANS).

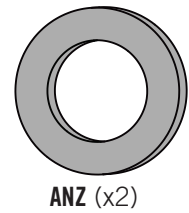
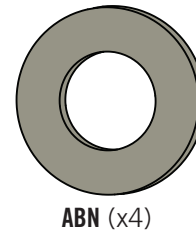
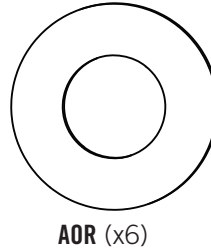
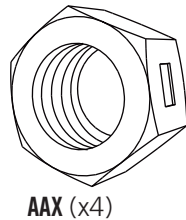
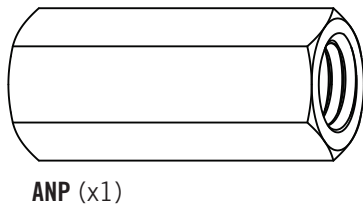

### PARTS REQUIRED

#### Metal Part

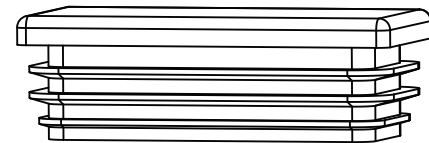
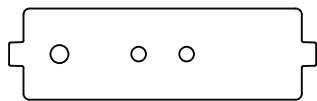
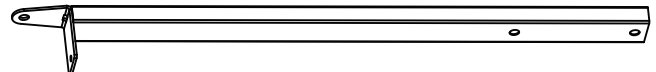
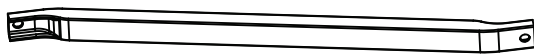

### TOOLS REQUIRED

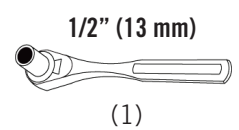
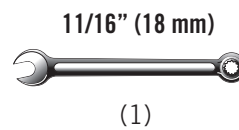
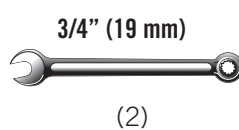
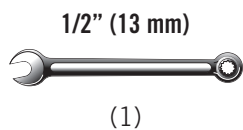
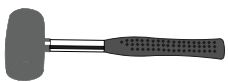

## ► SECTION 4 (CONTINUED)

TOOLS AND HARDWARE REQUIRED

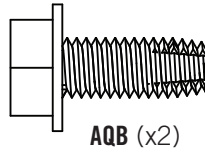
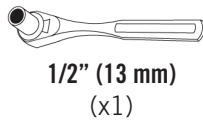
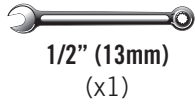

### 4.1

- Insert one end of the **Tie Plate (BLC)** into the slot on the **Lower Extension Arm (BGP)**, then insert the opposite end of the **Tie Plate (BLC)** into the slot on the other **Lower Extension Arm (BGP)** as shown.

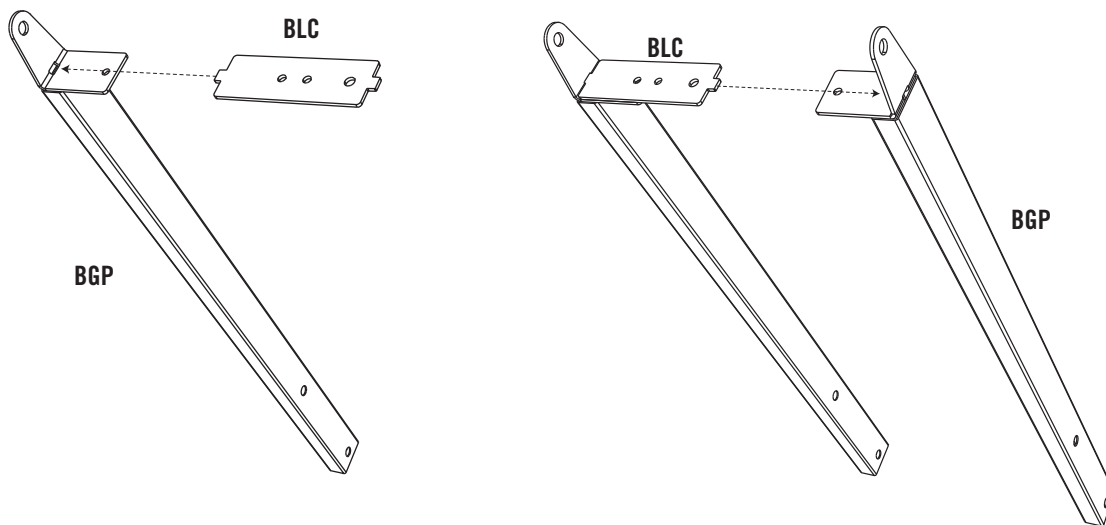

### 4.2

- Secure the **Lower Extension Arms (BGP)** together with the hardware shown. Use a 1/2" Socket Wrench to screw the **Thread-Cutting Bolts (AQB)** through the Lower Extension Arms and the **Tie Plate (BLC)**.

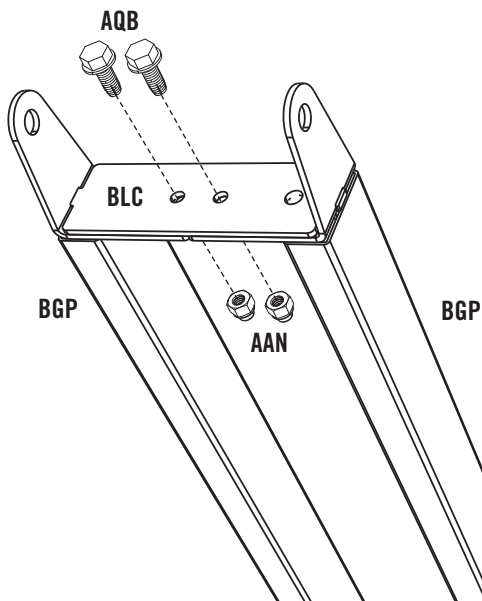

- *Do not overtighten the Cap Nut. If the end of the Bolt breaks through the plastic cap, call our Customer Service Department. Exposed threads on the end of the Bolt may cause serious injuries.*

## ► SECTION 4 (CONTINUED)

TOOLS AND HARDWARE REQUIRED / HERRAMIENTAS Y ACCESORIOS REQUERIDOS / OUTILS ET ACCESSOIRES REQUIS

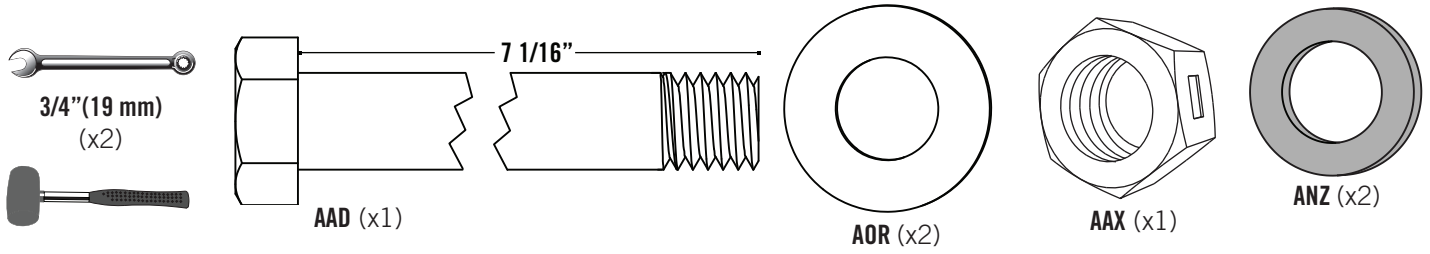

### 4.3

- Insert the **Extension Arm Caps (AQC)** into the ends of the **Lower Extension Arms (BGP)** as shown.

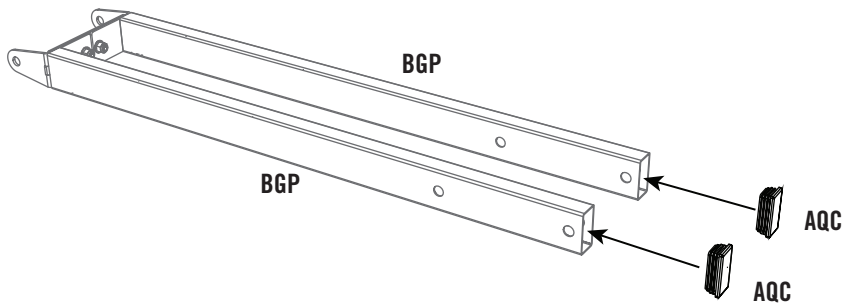

### 4.4

- Place the **Top Pole (ALH)** to the **Lower Extension Arms (BGP)** and secure them with the hardware shown.

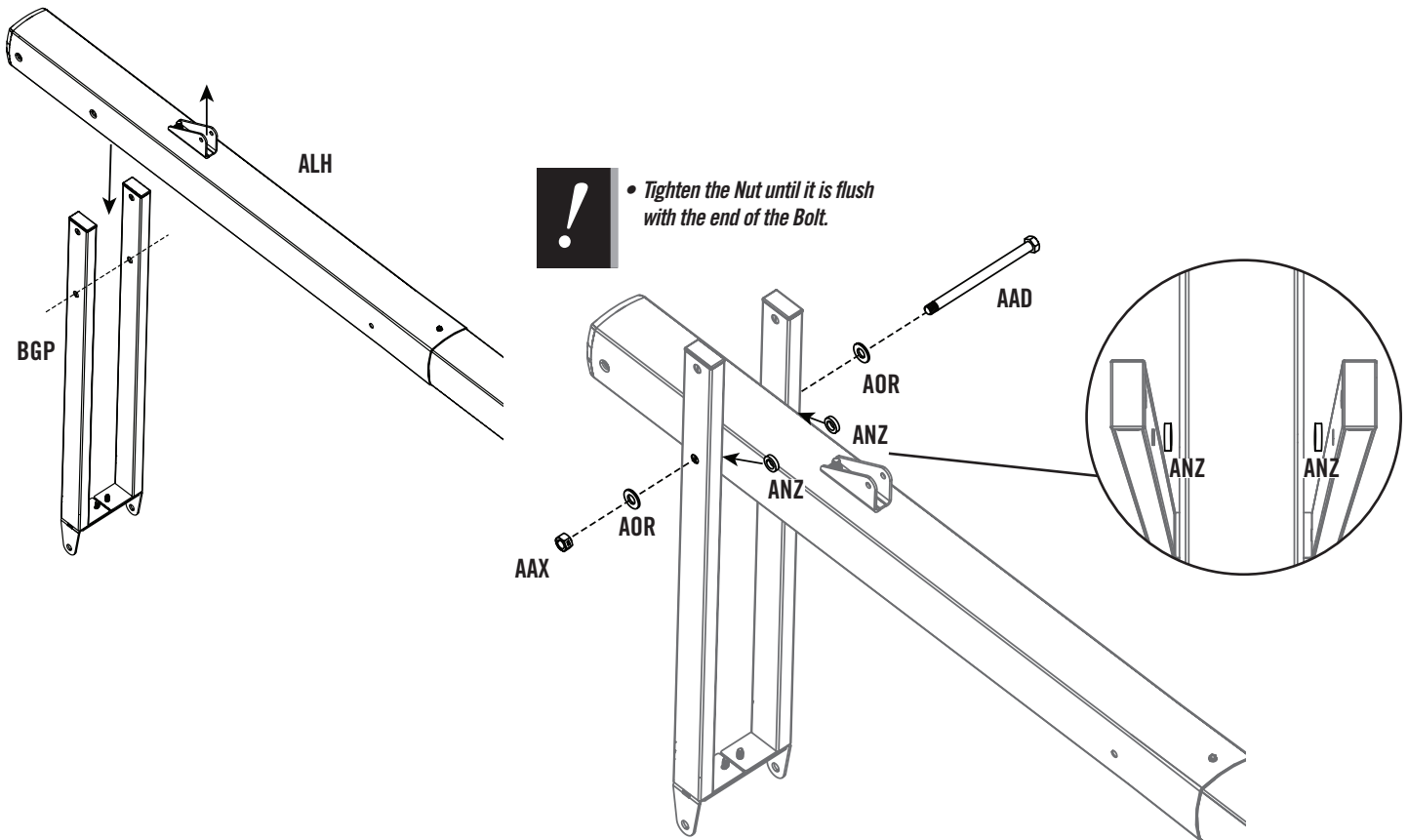

## SECTION 4 (CONTINUED)

TOOLS AND HARDWARE REQUIRED

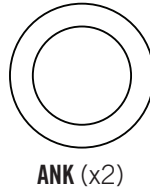
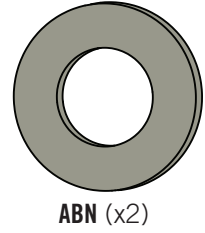
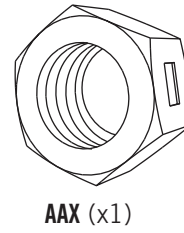
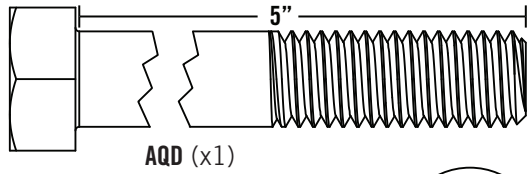

# 4.5

- Attach the **Upper Extension Arms (BGO)** to the **Top Pole (ALH)** with the hardware as shown.

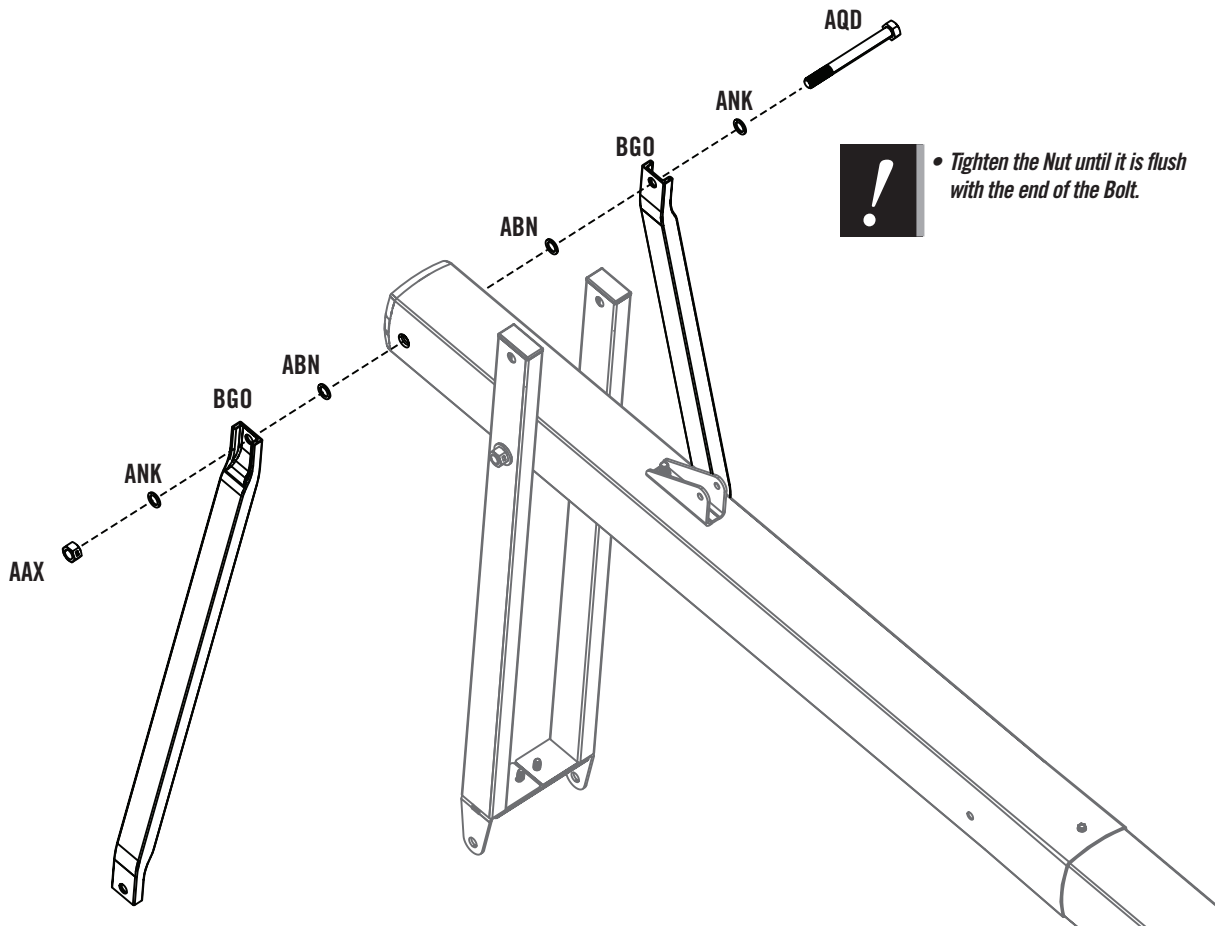

## SECTION 4 (CONTINUED)

### TOOLS AND HARDWARE REQUIRED



3/4" (19 mm)  
(x2)



1 1/16" (18 mm)  
(x1)

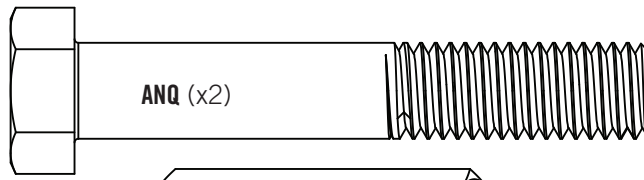

ANQ (x2)

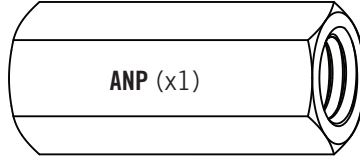

ANP (x1)

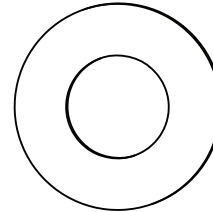

AOR (x2)

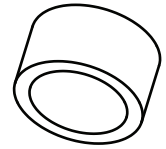

ABP (x2)

## 4.6

- Rest the Rim on cardboard to prevent scratching, then secure the **Lower Extension Arms (BGP)** to the **Backboard (AJI)** with the hardware shown. Screw the **Nut Coupler (ANP)** onto one of the **Hex Bolts (ANQ)**, then onto the other. Center the coupler between the two Bolts as shown.

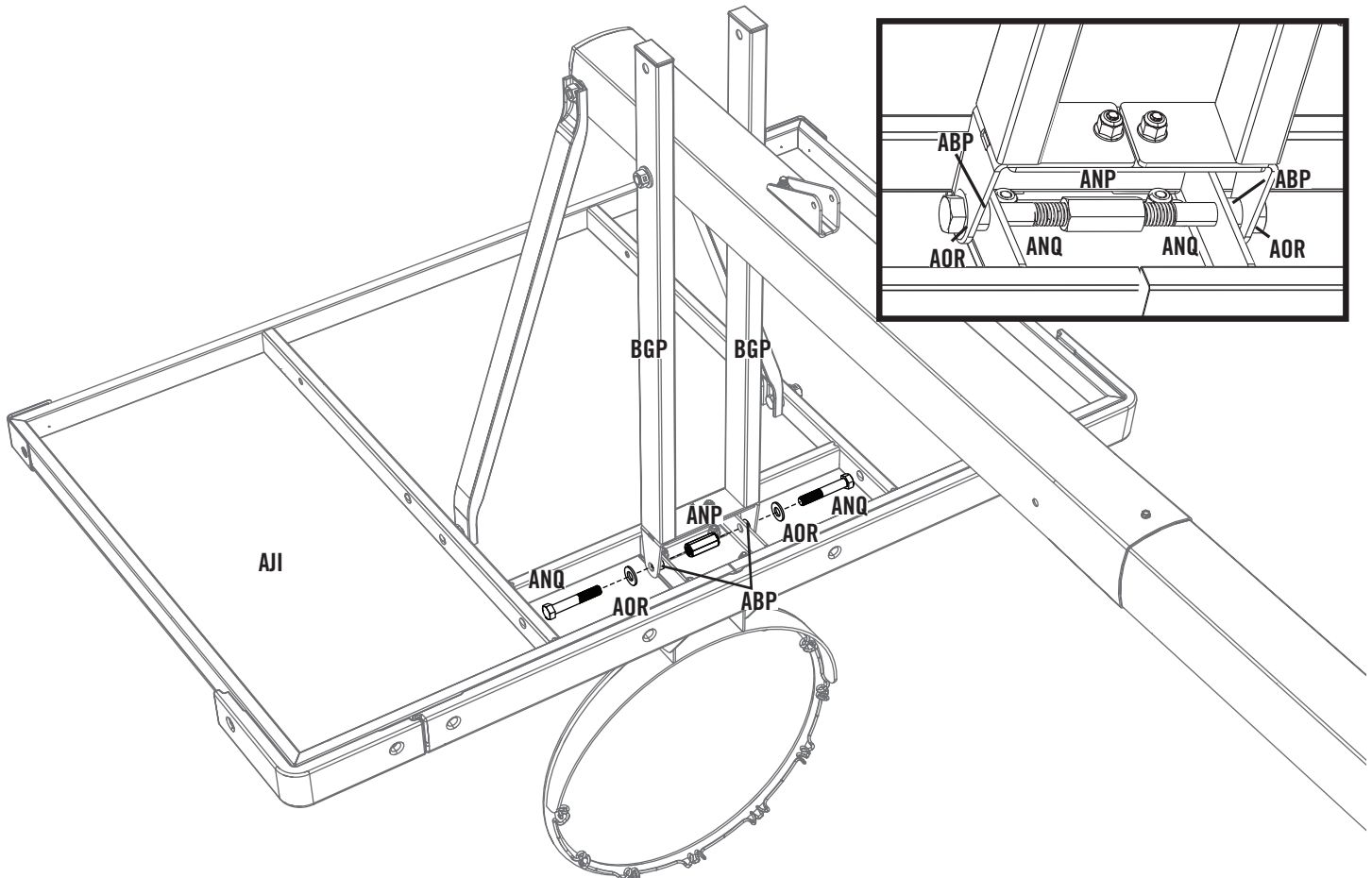

- Make sure the 1/2" x 3/8" Poly Spacers (ABP) positioned between the Lower Extension Arms and the Backboard do not bulge.





**This page intentionally left blank**

**Remove This Section Before Assembling**



# PARTS IDENTIFIER

Metal Part

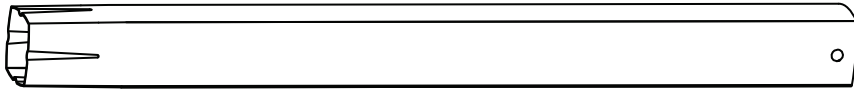

ALE (x1)

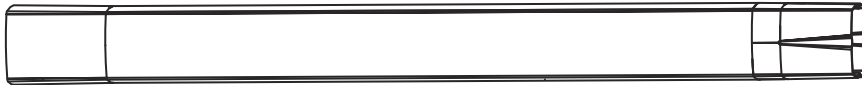

ALF (x1)

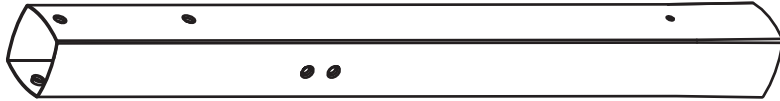

ALH (x1)

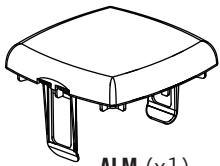

ALM (x1)

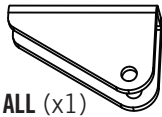

ALL (x1)

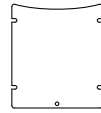

AMA (x1)

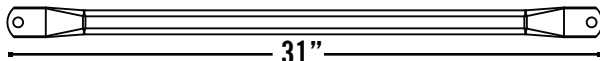

ALS (x2) (78.7 cm)

31"

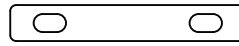

BGR (x1)

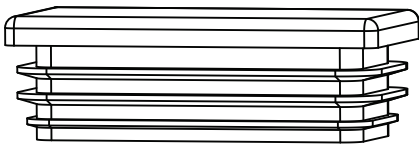

AQC (x2)

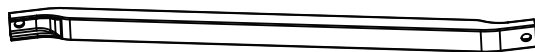

BGO (x2)

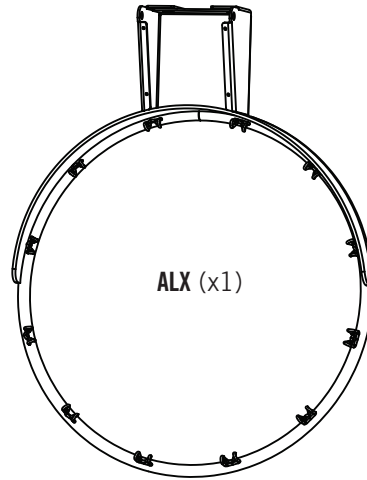

ALX (x1)

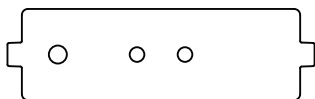

BLC (x1)



BGP (x2)

Hardware shown at 50% of Actual Size

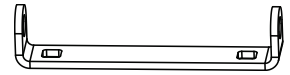

APY (x1)

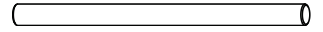

ABQ (x1)

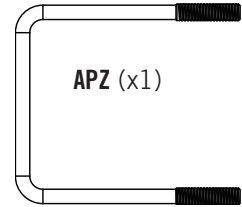

APZ (x1)



AOW (x1)



AJW (x2)

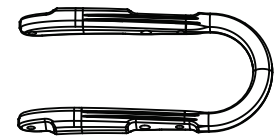

AKI (x1)

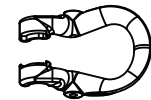

AMN (x1)

Hardware shown at 25% of Actual Size

Remove This Section Before Assembling



# PARTS IDENTIFIER

## Plastic Parts

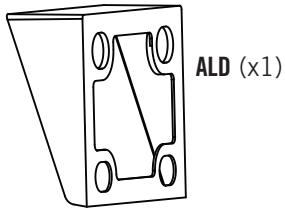

ALD (x1)

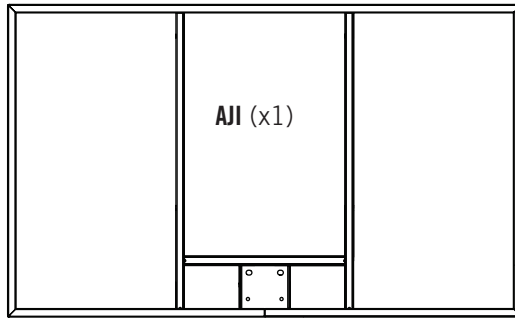

AJI (x1)

## Paper Parts

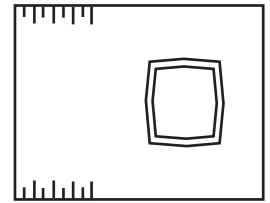

BGW (x1)

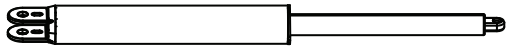

AKF (x1)



AKG (x1)

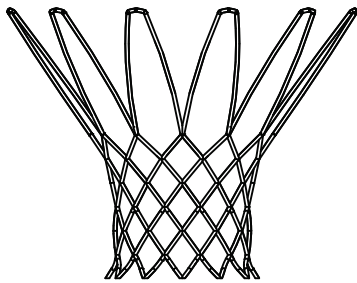

AKZ (x1)



AJQ (x2)

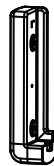

BAA (x1)

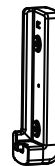

BAB (x1)



AKP (x1)

Remove This Section Before Assembling



# HARDWARE REQUIRED

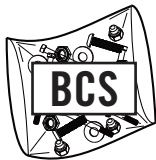



**Remove This Section Before Assembling**

**This page intentionally left blank**

## SECTION 4 (CONTINUED)

TOOLS AND HARDWARE REQUIRED

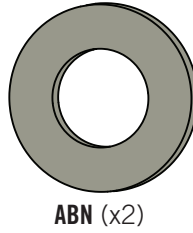
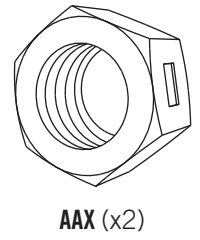
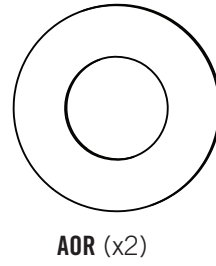
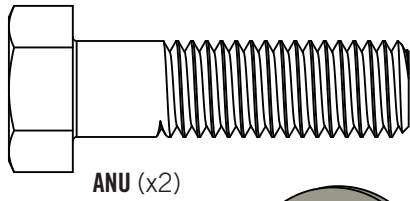
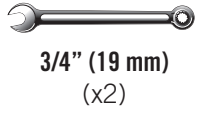

# 4.7

- Attach the **Upper Extension Arms (BGO)** to the **Backboard (AJI)** with the hardware as shown.

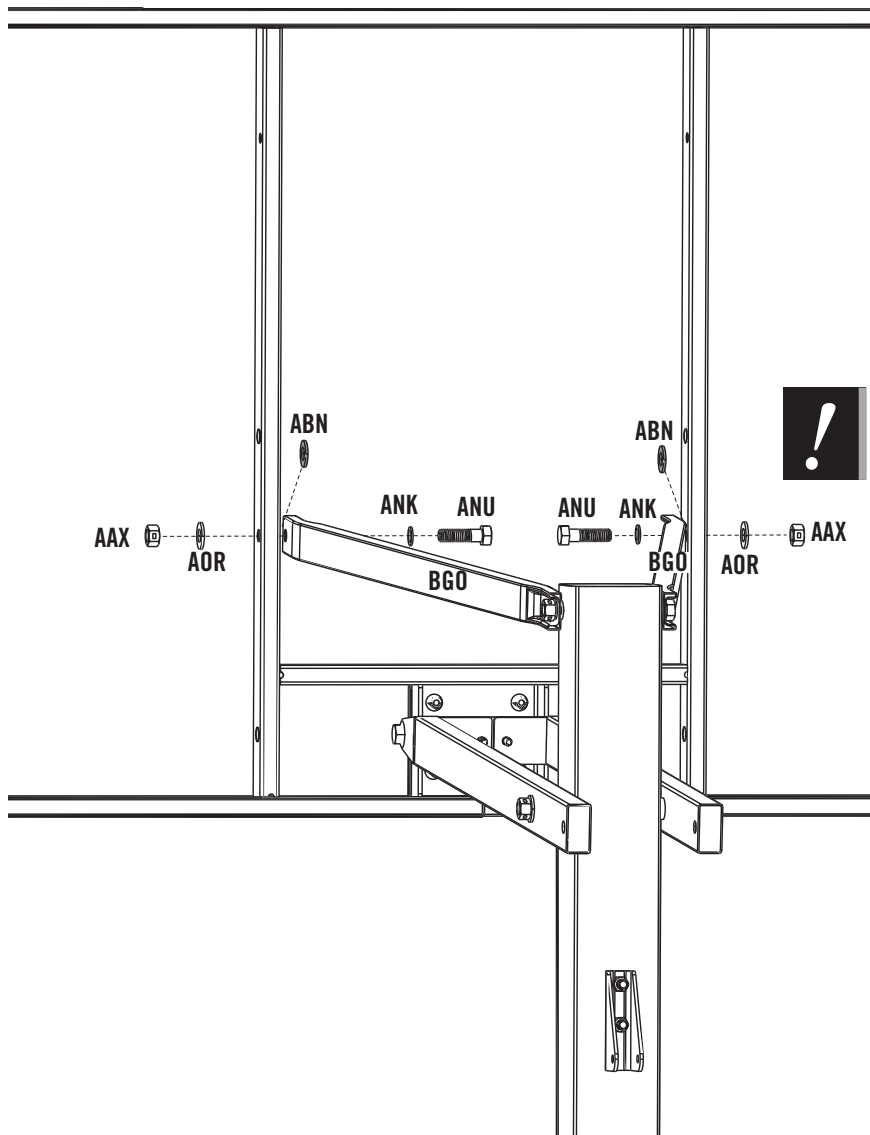

► **SECTION 4 (CONTINUED)**

TOOLS AND HARDWARE REQUIRED

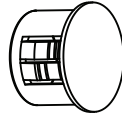

**ANS** (x4)

*\*Hardware Bag BCR  
may include extra Plastic  
Plugs (ANS).*

**4.8**

- Insert 1/2" Nylon Plugs (ANS) into the locations indicated on the back of the **Backboard (AJI)**.

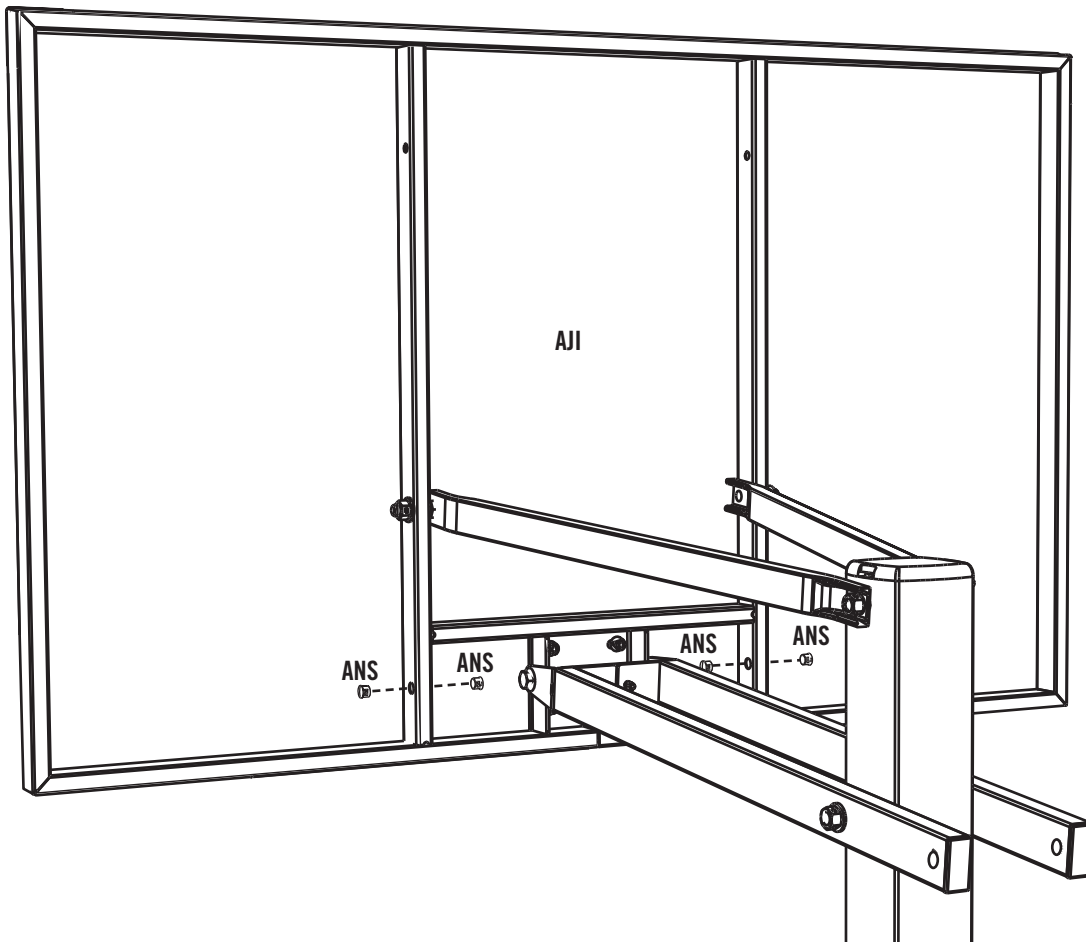

# 5

## HANDLE ASSEMBLY



### HARDWARE REQUIRED

#### Hardware Bag

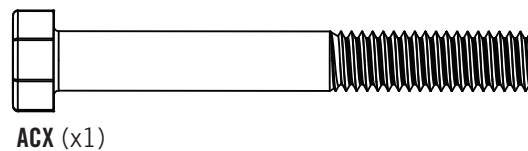
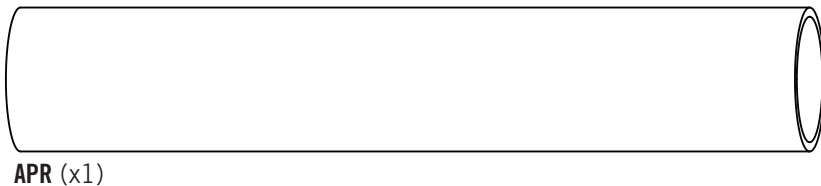
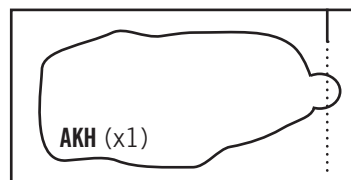
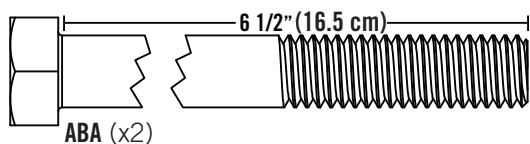
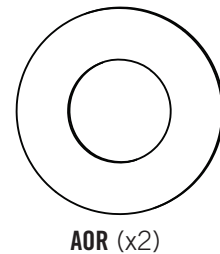
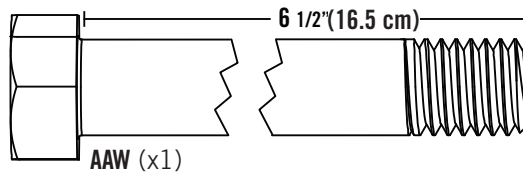
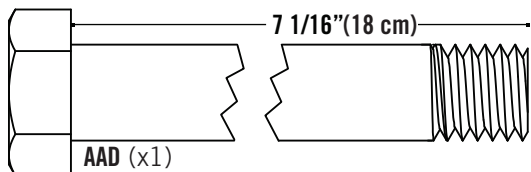
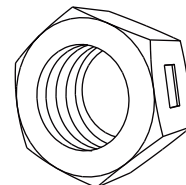
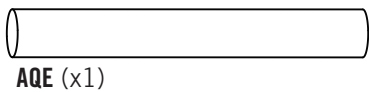

### PARTS REQUIRED

#### Metal Part

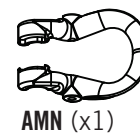
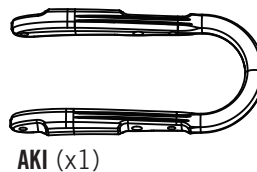
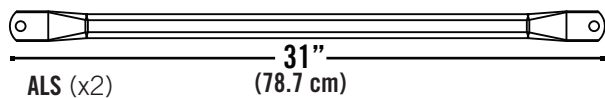

#### Plastic Parts

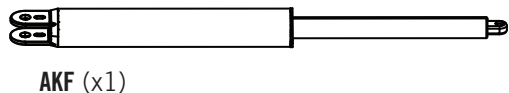

### TOOLS REQUIRED

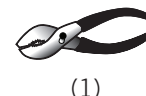
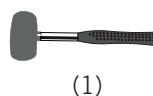
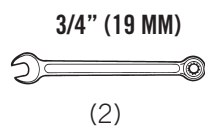
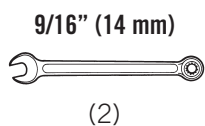
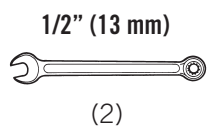

## ► SECTION 5 (CONTINUED)

TOOLS AND HARDWARE REQUIRED

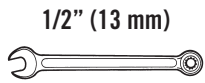

(2)

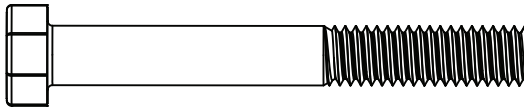

ACX (x1)



BSG (x1)

### 5.1

- Slide the **Gas Spring Cover (AKG)** onto the **Gas Spring (AKF)** as shown.

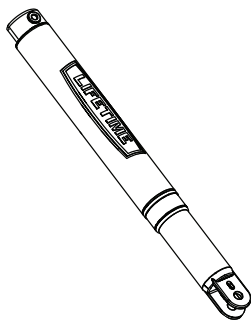
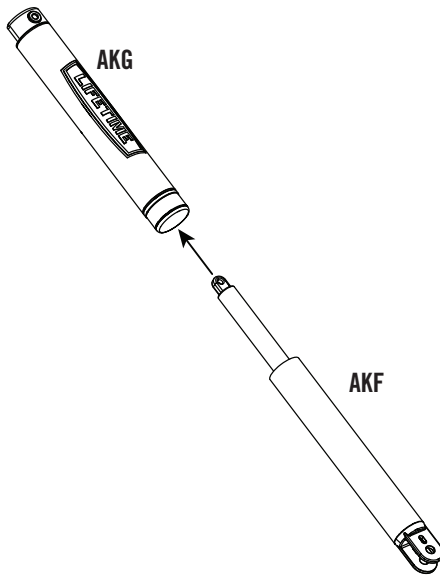

### 5.2

- Align the holes in the **Gas Spring Cover (AKG)** and the **Gas Spring (AKF)** with the holes in the **Pole Bracket (ALL)**, and attach the Gas Spring assembly to the Pole Bracket with the hardware shown.

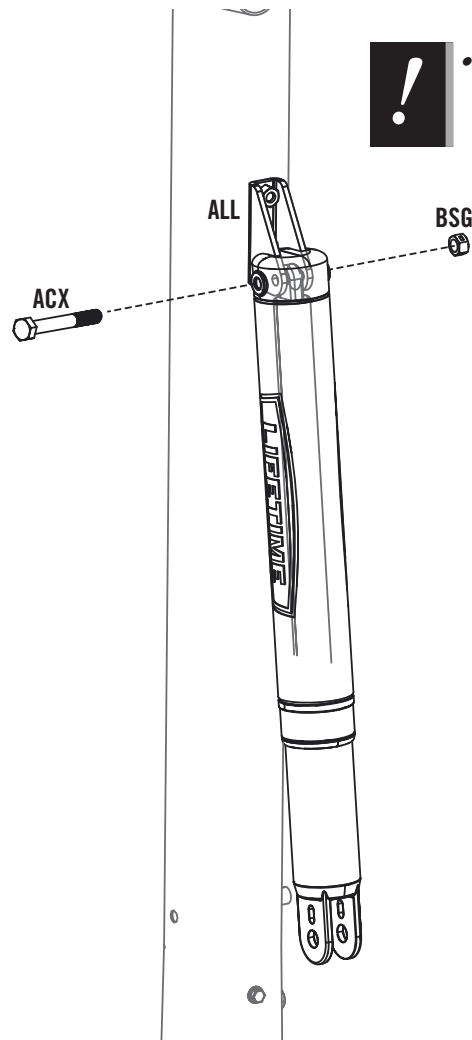

- **Tighten the Centerlock Nut (BSG) until it is flush with the end of the Bolt.**

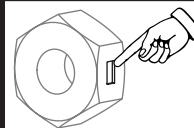

- A Centerlock Nut will require some effort to thread onto a Bolt. See page 2 for details.



## ► SECTION 5 (CONTINUED)

TOOLS AND HARDWARE REQUIRED

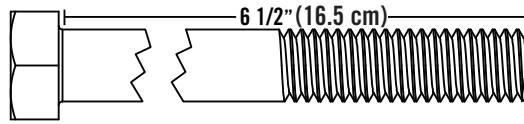
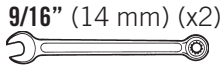

ABA (x2)

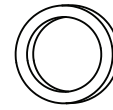

AQF (x2)



ABB (x2)

### 5.3

- Position the **Trigger (AMN)** inside of the **Handle (AKI)** as shown, and secure the Trigger to the Handle with the hardware shown. Make sure the Nut is flush with the end of the Bolt, and be careful not to overtighten the hardware.

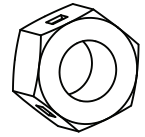
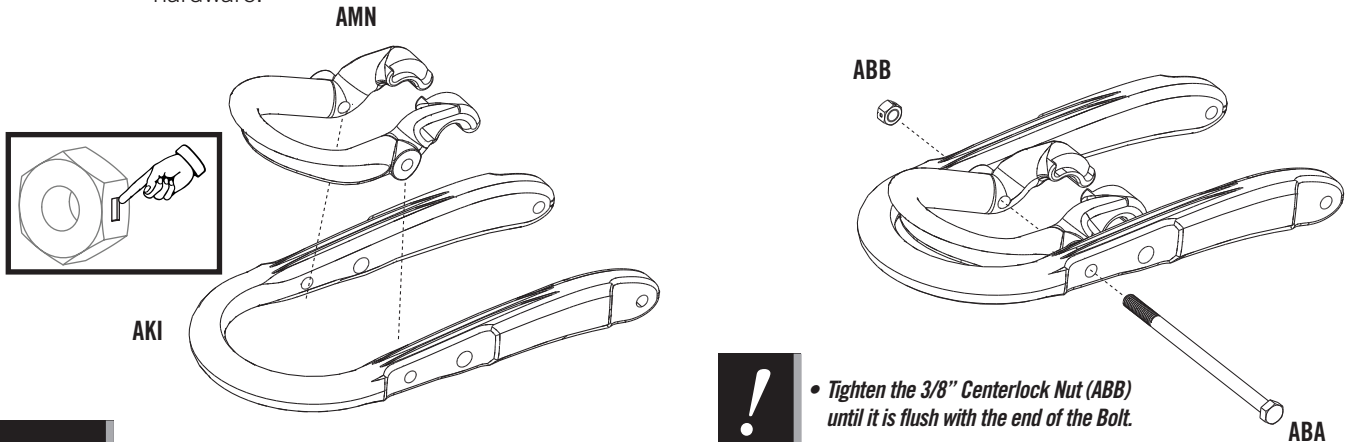

### 5.4

- Secure the **Handle (AKI)** to the **Top Pole (ALH)** with the hardware shown. Make sure to place the **Spacers (AQF)** between the Handle Assembly and the Top Pole as shown.

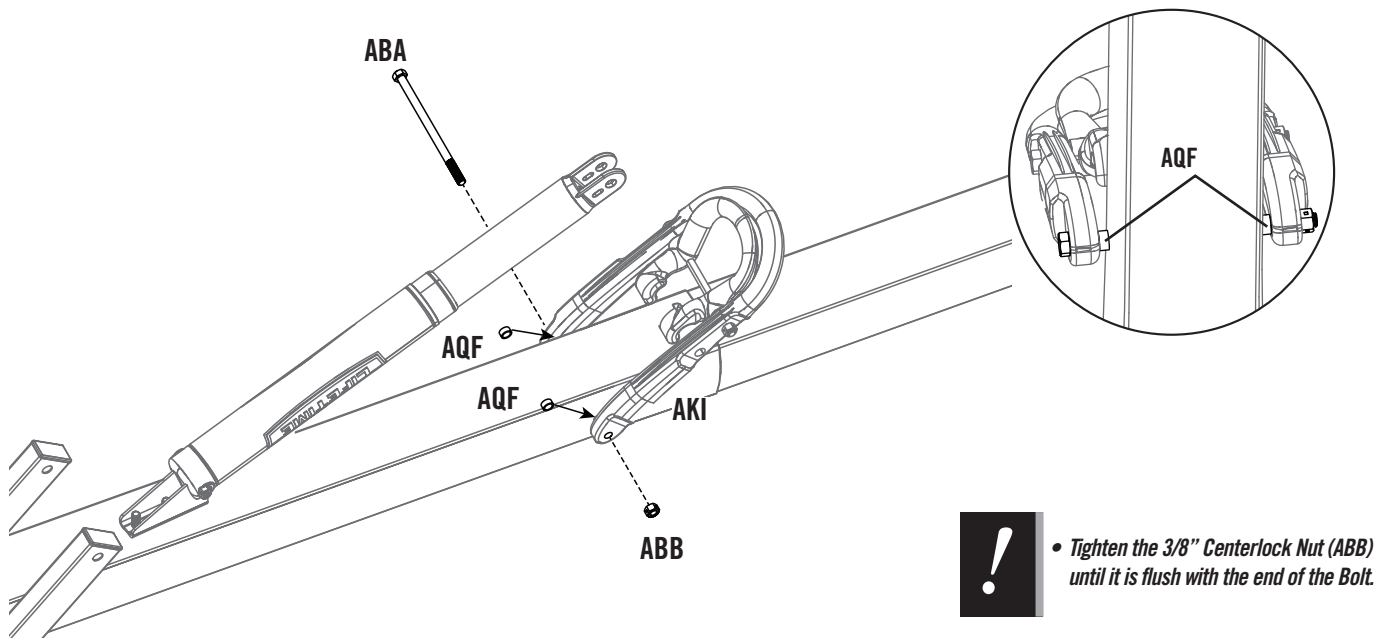

## ► SECTION 5 (CONTINUED)

TOOLS AND HARDWARE REQUIRED

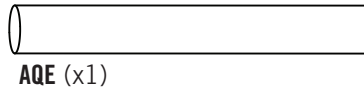

# 5.5

- Insert the **Release Pin (AQE)** through the **Gas Spring (AKF)**. Slide the **Handle (AKI)** under the **Gas Spring (AKF)** so that the **Release Pin (AQE)** rests in the channels of the **Trigger (AMN)**.

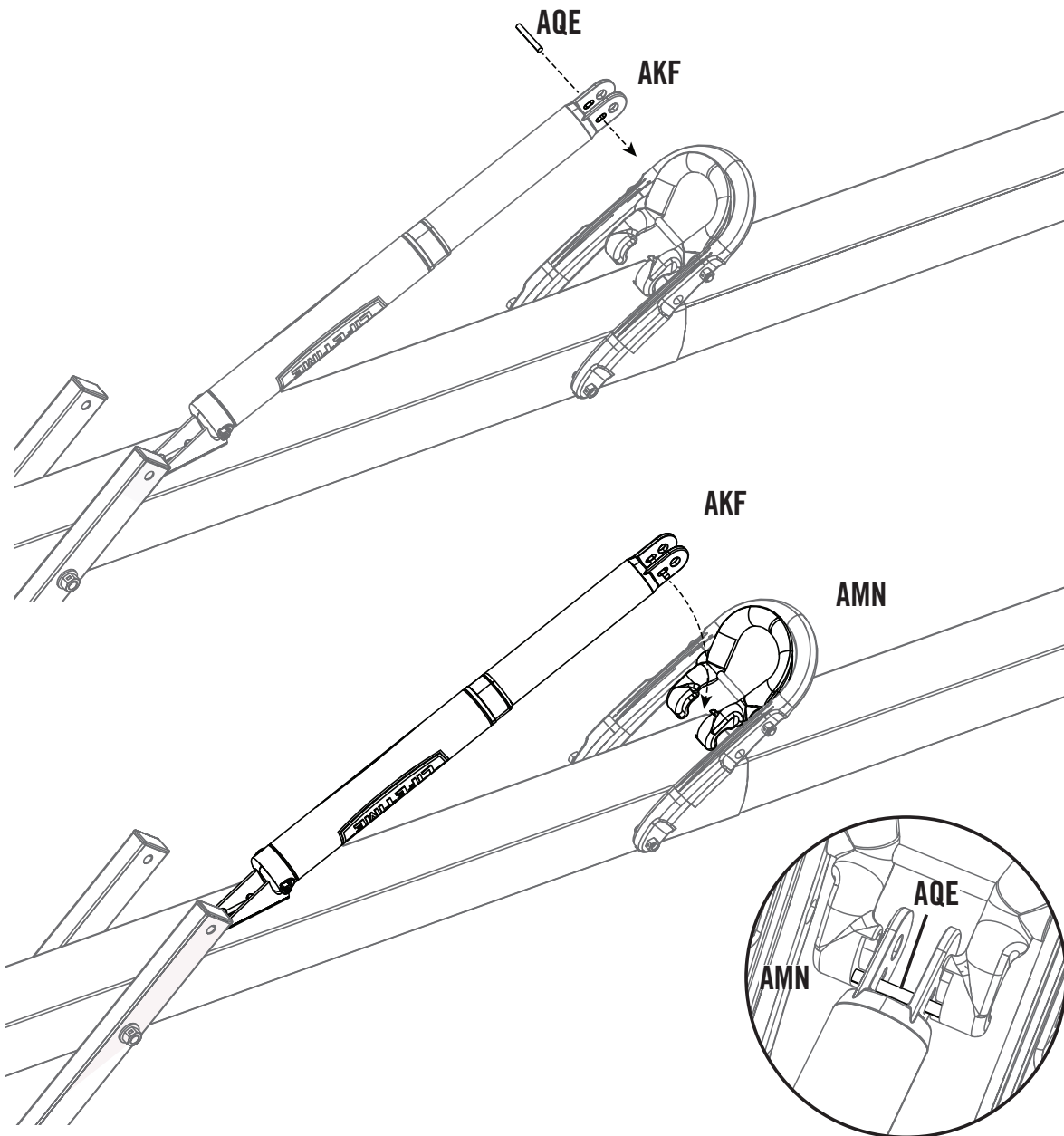

## SECTION 5 (CONTINUED)

TOOLS AND HARDWARE REQUIRED

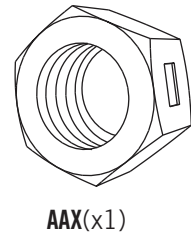
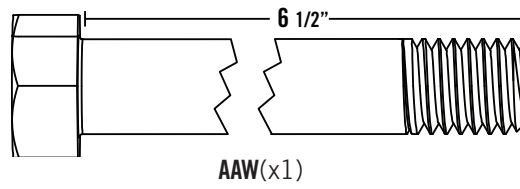
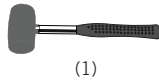
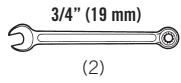

### 5.6

- Position the **Rear Lifter Arms (ALS)** between the Handle and Trigger, and secure with the hardware shown.

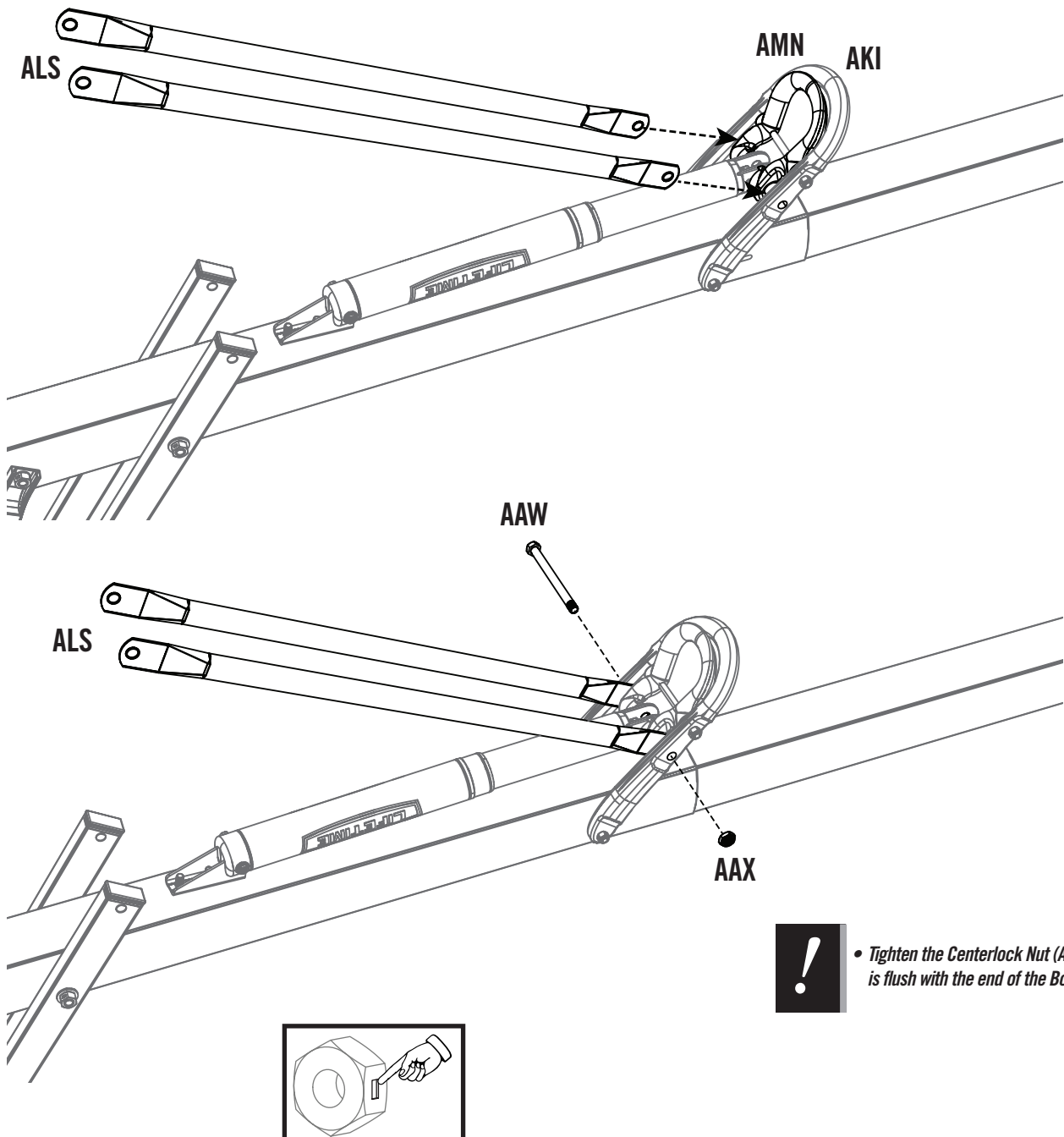

## SECTION 5 (CONTINUED)

TOOLS AND HARDWARE REQUIRED

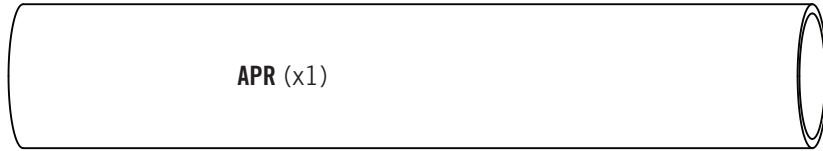
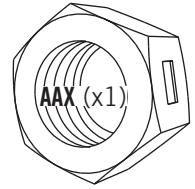
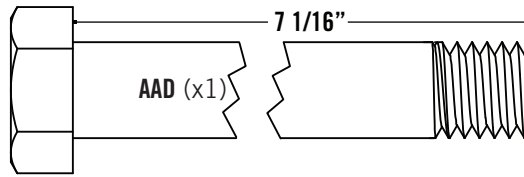
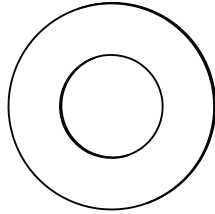
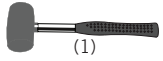
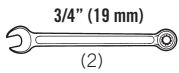

# 5.7

- Connect the **Rear Lifter Arms (ALS)** to the inside of the **Long Extension Arms (AKB)** with the hardware shown. Place a **Spacer (APR)** between the Rear Lifter Arms as shown.

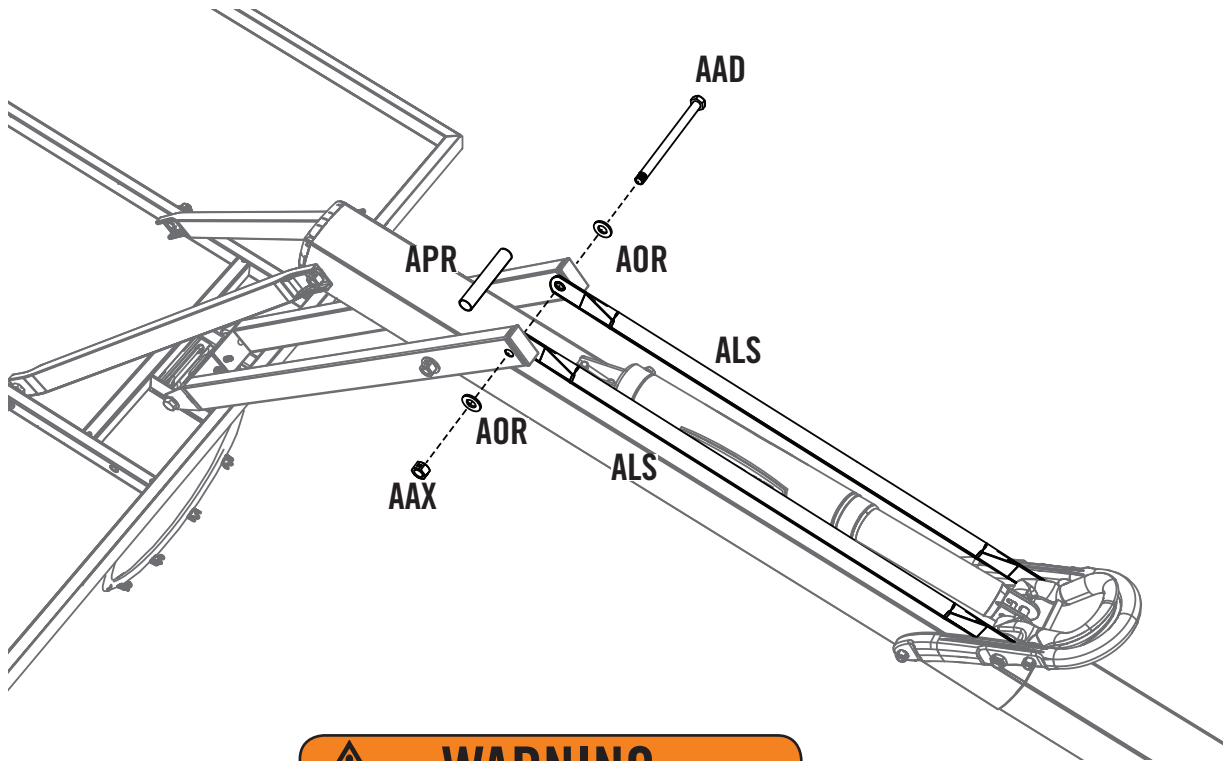

## WARNING

The Handle mechanism is designed to lift only the weight of the Backboard and Rim. Do not hang anything from the Handle, Rim, Backboard, or Lifter Arms as this will damage the system and void the warranty.

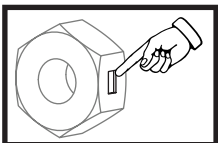

- *Tighten the 1/2" Centerlock Nut (AAX) until it is flush with the end of the Bolt.*

► SECTION 5 (CONTINUED)

TOOLS AND HARDWARE REQUIRED

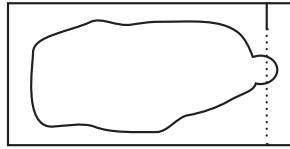

AKH (x1)

5.8

- Apply grease from the **Grease Packet (AKH)** on to the **Release Pin (ALV)**.

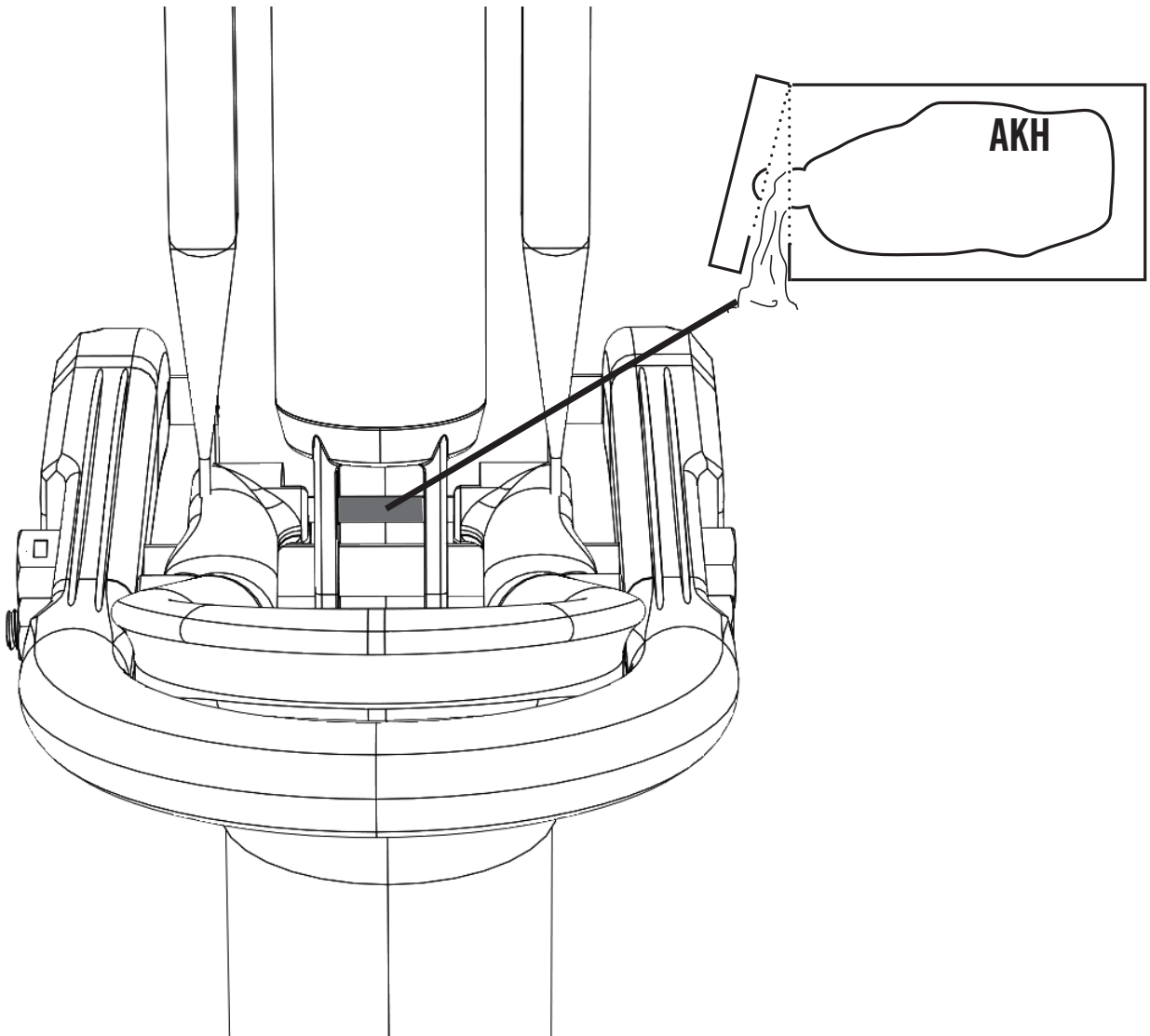

# 6

## FINAL ASSEMBLY



### HARDWARE REQUIRED

Hardware Bag

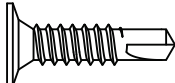
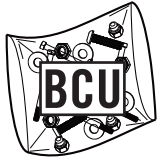

ADP (x10)



CMV (x1)

(\*This Hardware taken from the hardware bag used in Section 2.)



### PARTS REQUIRED

Plastic Parts

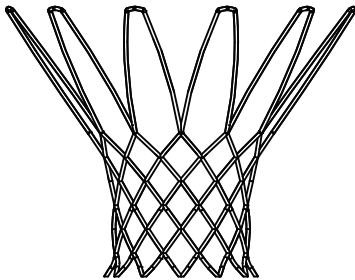

AKZ (x1)



AJQ (x2)



BAA (x1)



BAB (x1)



AKP (x1)



### TOOLS REQUIRED



(1)



(1)



(3)



(1)  
(not included)

## ► SECTION 6 (CONTINUED)

TOOLS AND HARDWARE REQUIRED

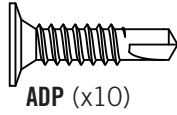

### 6.1

- Secure the **Corner Frame Pads (BAA and BAB)** to the **Backboard (AJI)** with the **Self-Tapping Screws (ADP)**.

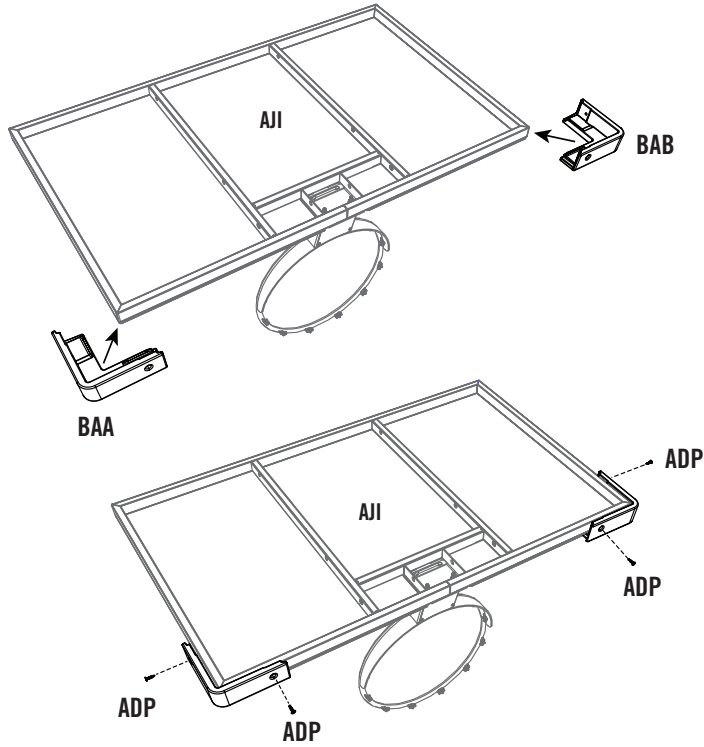

### 6.2

- Attach the **Center Frame Pads (AJQ)** to the **Backboard (AJI)** in the locations shown with the hardware shown.

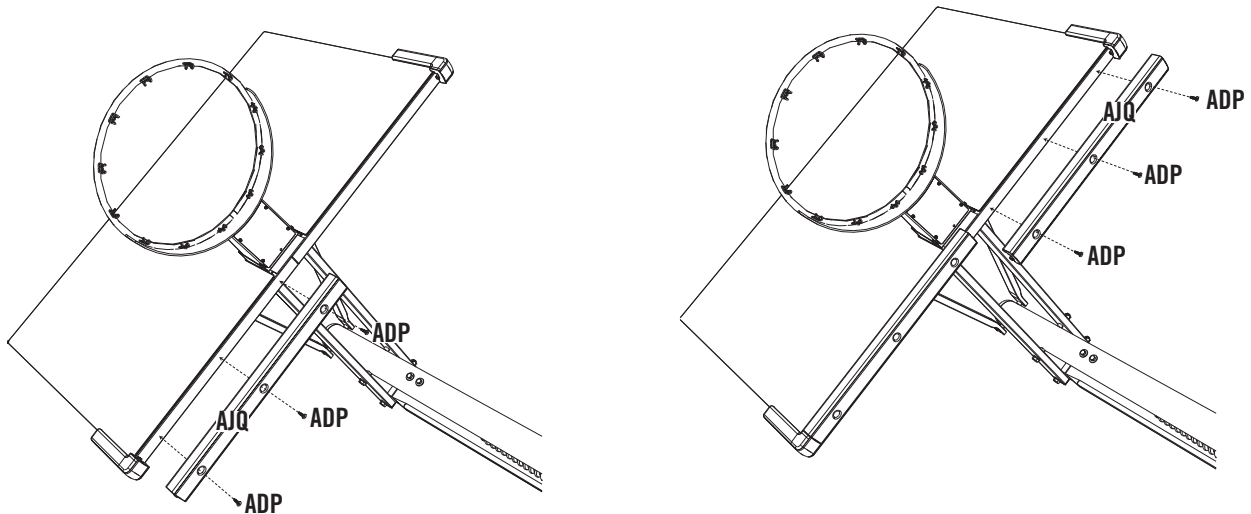

## ► SECTION 6 (CONTINUED)

TOOLS AND HARDWARE REQUIRED



(3)

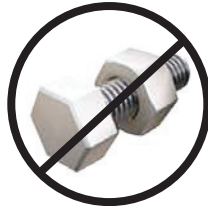

### 6.3

**AT LEAST THREE ADULTS ARE REQUIRED. DO NOT ATTEMPT ASSEMBLY WITH FEWER THAN THREE ADULTS AND THREE LADDERS.**

**BEFORE CONTINUING:** It is critical that the instructions in the following steps are followed exactly. Failure to properly orient and align the pole sections will render the pole unusable. If the pole sections are assembled incorrectly, you will have to purchase new pole sections from our Customer Service Department. If you have questions regarding the pole assembly, please call our Customer Service Department for assistance.

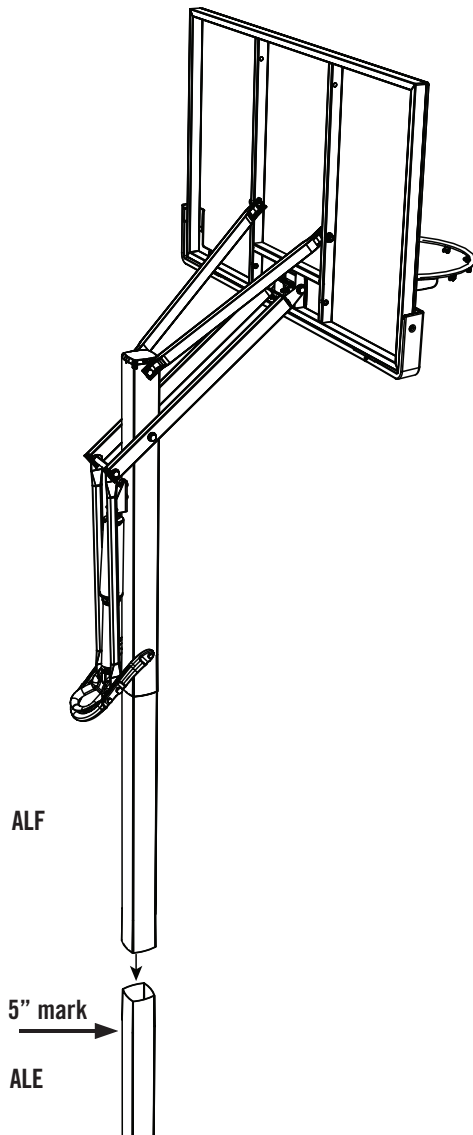

- Make a mark 5 inches from the top of the **Bottom Pole (ALE)**. With the Backboard facing the playing surface, carefully slide the Top/Middle Pole assembly over the Bottom Pole. Adjust the system to the 7.5-foot setting.



### WARNING

Use extreme caution when standing on ladders to perform assembly steps. Follow all warnings and cautions on the ladder. Failure to follow all of these instructions and warnings could lead to serious personal injury or property damage.



## ▶ SECTION 6 (CONTINUED)

### TOOLS AND HARDWARE REQUIRED



## 6.4

### ATTENTION: THIS STEP CANNOT BE REVERSED!

To prevent serious injuries, two adults are required to complete assembly.

- While two people continue to hold the assembly in place, set a block of Scrap Wood on top of the Rigid Arms and strike it 5-6 times with a hammer or mallet. **You must have wood on top of the Arms before hitting them with a hammer to prevent scratching the powder coating.** The bottom edge of the Middle Pole must reach within 1/2 inch of the 5-inch mark on the Bottom Pole.

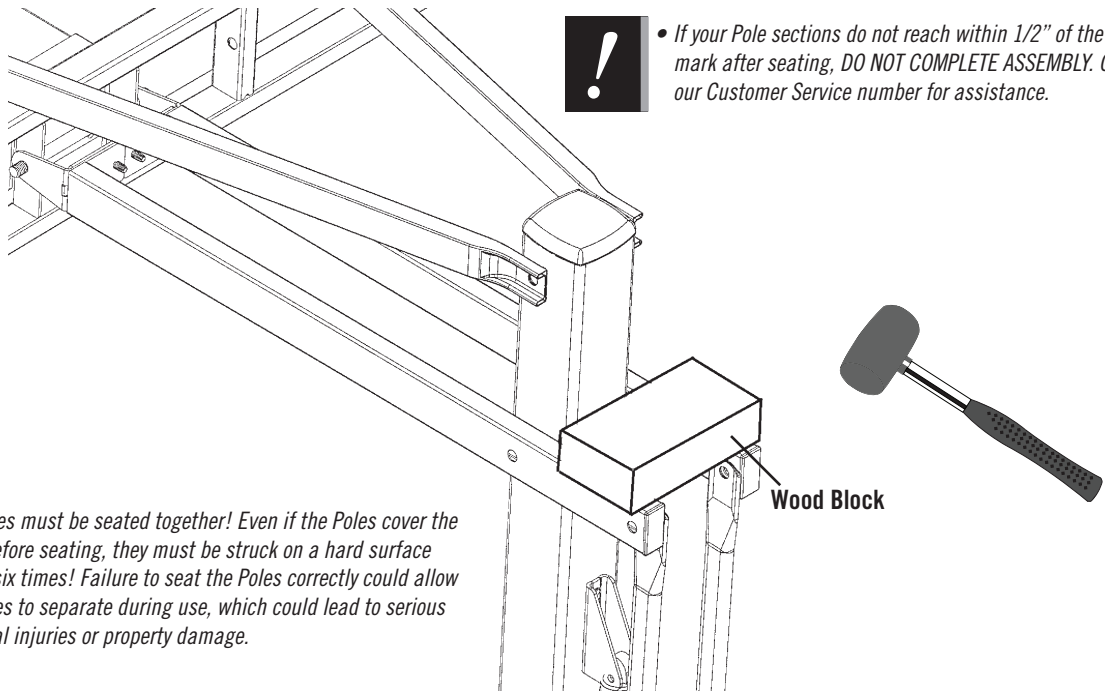

- **The Poles must be seated together! Even if the Poles cover the slots before seating, they must be struck on a hard surface five to six times! Failure to seat the Poles correctly could allow the Poles to separate during use, which could lead to serious personal injuries or property damage.**

- **If your Pole sections do not reach within 1/2" of the 5" mark after seating, DO NOT COMPLETE ASSEMBLY. Call our Customer Service number for assistance.**

 **WARNING**  
The Poles must be seated together! Even if the Poles cover the slots before seating, they must be struck on a hard surface five to six times! Failure to seat the Poles correctly could allow the Poles to separate during use, which could lead to serious personal injuries or property damage.

## ► SECTION 6 (CONTINUED)

TOOLS AND HARDWARE REQUIRED

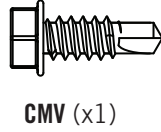

### 6.5

- After the Poles have been seated, measure up 1" from the bottom center of the **Middle Pole (ALF)** and insert one **Self-Tapping Screw (CMV)** into the Pole as shown.

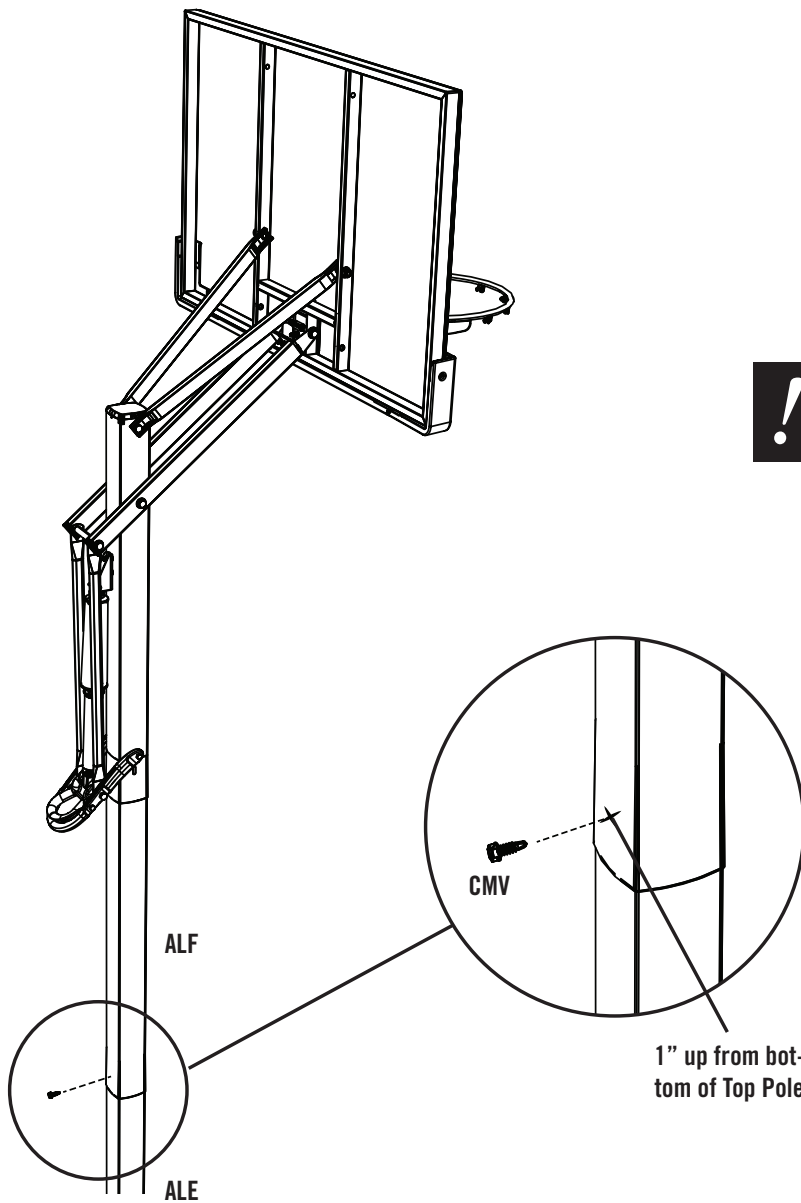

- *Chuck the Self-Tapping Screw directly into an Electric Drill for easy installation, or use a 3/8" Hex Driver.*

## ► SECTION 6 (CONTINUED)

TOOLS AND HARDWARE REQUIRED



### 6.6

- Attach the **Net (AKZ)**.

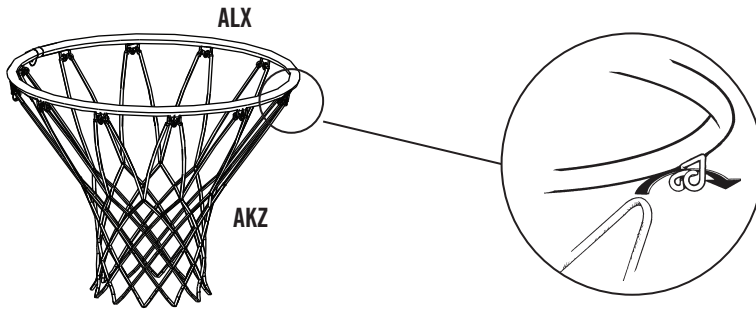

• *Note! If a replacement Net is needed, please call our Customer Service Department. Our Nets are shorted than average to reduce the risk of entanglement.*

### 6.7

- Remove protective cover.

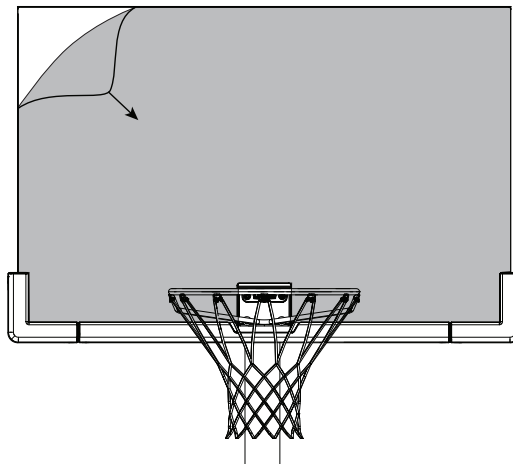

## ► SECTION 6 (CONTINUED)

TOOLS AND HARDWARE REQUIRED



### 6.8

- Raise the Backboard as high as it will go. Use a pencil to mark the bottom of the **Gas Spring Cover (AKG)** where it meets the **Gas Spring (AKF)**. Squeeze the sides of the Gas Spring Cover inward so you can apply the **Height Adjustment Sticker (AKP)** under the Cover and onto the back of the Gas Spring, lining up the **10'** line with the pencil mark. Press the Sticker into place while slowly removing the rest of the backing.

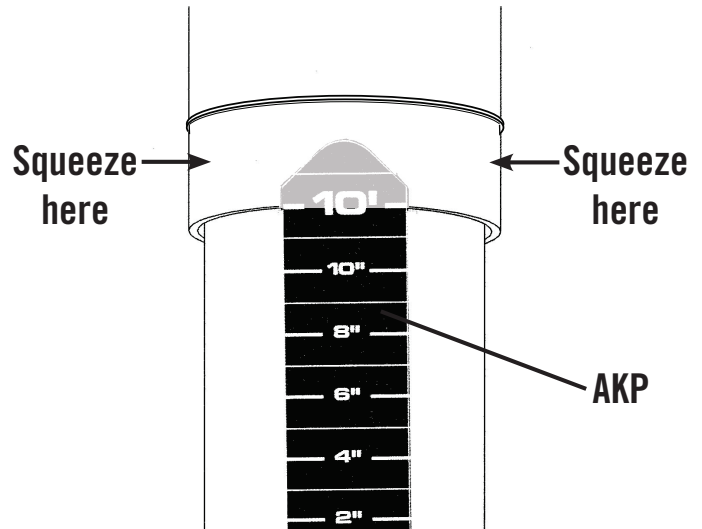
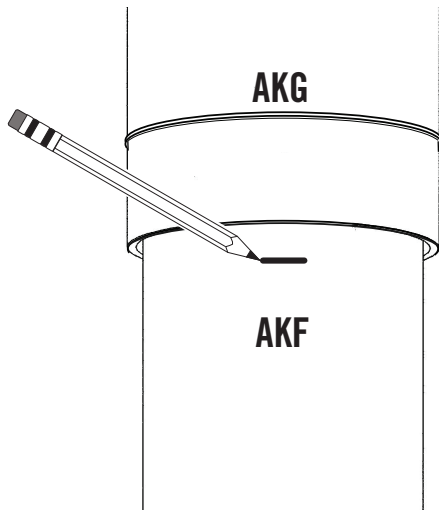

- *Actual Height Sticker (AKP) and Gas Spring Cover (AKG) may vary from those shown here.*



## MAINTENANCE

The life of your basketball system depends on many variables. The climate, exposure to corrosives such as salt, pesticides, or herbicides, and excessive use or misuse can all contribute to Pole failure, which may cause property damage or personal injury.

Check your basketball system frequently for loose hardware, excessive wear, and signs of corrosion. For safety reasons, and to prolong the life of your basketball system, you must take the following preventive measures.

- a. Check all Nuts and Bolts. If any are loose, tighten them.
- b. Check all parts for excessive wear and tear. If necessary, replace any parts that have been worn or damaged through usage. Contact our Customer Service Department for replacement parts.
- c. Inspect the Warning Sticker on the Pole. If it is ripped, faded, or illegible, call our Customer Service Department to request a replacement Sticker.
- d. Check all Pole sections for visible rust or chipped or cracked paint. If either are present, do the following:
  1. Use an emery cloth to completely remove any rust or chipped paint.
  2. Clean the area with a damp cloth and allow it to dry.
  3. Apply two coats of a rust preventative, high gloss enamel paint to the area. Allow the paint to dry between coats.

**IF RUST HAS PENETRATED THROUGH THE POLE ANYWHERE, REPLACE IT IMMEDIATELY!**



## REGISTER YOUR PRODUCT ONLINE AT [WWW.LIFETIME.COM](http://WWW.LIFETIME.COM)

At Lifetime®, we are committed to providing innovative and quality products. While registering, you will have the opportunity to give us your feedback. Your input is valuable to us.

- You can also opt in to receive new product notifications or promotions.
- In the unlikely event of a product recall or safety modification, your registration provides the information we need to notify you directly.
- Registration is fast, easy, and completely voluntary.

### **LIFETIME'S PROMISE TO YOU:**

*Maintaining your privacy is our long-standing policy at Lifetime®. And you can rest assured that Lifetime® will not sell or provide your personal data to other third parties, or allow them to use your personal data for their own purposes.*

We invite you to read our privacy policy at [www.lifetime.com](http://www.lifetime.com)

**REGISTER today!**



## WARNING STICKER



### WARNING



#### FAILURE TO FOLLOW THESE WARNINGS MAY RESULT IN SERIOUS INJURY AND/OR PROPERTY DAMAGE.

Owners must ensure that all players know and follow these rules for safe operation of the system.

- Only hang from the rim briefly to regain balance or avoid injuring others. Release the rim as soon as safely possible.
- During play, especially when performing dunk type activities, keep player's face away from the backboard, rim, and net. Serious injury could occur if teeth/face come in contact with the backboard, rim, or net. Player should wear a mouth guard during play.
- Do not slide, climb, or play on pole.
- When adjusting height or moving system, keep hands and fingers away from moving parts.
- Do not allow children to move or adjust system.
- Do not wear jewelry (rings, watches, necklaces, etc.) during play. Objects may entangle in net.

- Keep organic material away from pole base. Grass, litter, etc. could cause corrosion and/or deterioration.
- Once a month check pole and all metal parts for signs of corrosion (rust, pitting, chipping). Completely remove rust and repaint with exterior enamel. If rust has penetrated any steel part, replace that part immediately.
- Check system before each use for loose hardware, excessive wear, instability, and signs of corrosion and repair before use.
- Never play on damaged equipment.
- Do not use the system to lift or hoist anything. The mechanism is designed to lift only the weight of the backboard and rim. Do not hang anything from the handle, rim backboard, or lifter arms as this will damage the system and void the warranty.



### ADVERTENCIA



### AVERTISSEMENT



#### SI NO SE OBEDECEN ESTAS ADVERTENCIAS PUEDEN PRODUCIRSE GRAVES LESIONES Y/O DAÑOS A LA PROPIEDAD.

El propietario del sistema debe asegurarse de que todos los jugadores conozcan y respeten estas reglas para que el sistema se use en forma segura.

- Cuélguese del aro sólo en forma breve, para recuperar el equilibrio o evitar lesionar a otros jugadores. Suéltese del aro lo más pronto que pueda hacerlo con seguridad.
- Durante el juego, especialmente al embocar violentamente de alto, la cara de los jugadores debe mantenerse alejada del tablero, el aro y la red. Pueden producirse lesiones graves si los dientes o la cara entran en contacto con el tablero, el aro o la red. Los jugadores deben usar un protector bucal durante el juego.
- No se deslice, no trepe ni juegue sobre el poste.
- Mantenga las manos y los dedos alejados de las piezas móviles cuando regule la altura del sistema.
- No deje que los niños regulen el sistema.
- No use joyas (anillos, relojes, collares o gargantillas, etc.) durante el juego. Estos objetos pueden engancharse en la red.
- No permita que la base del poste entre en contacto con materiales orgánicos. El pasto, los desechos animales, etc., pueden causar corrosión y/o deterioros.
- Controle el poste y todas las piezas metálicas una vez al mes en busca de signos visibles de corrosión (oxidación, picaduras, escamado). Elimine todo rastro de óxido y vuelva a pintar con esmalte para exteriores. Si el óxido ha penetrado cualquier pieza de acero, reemplace esa pieza de inmediato.
- Inspeccione el sistema antes de cada uso para verificar que los elementos de fijación no estén flojos, que no haya desgaste excesivo, inestabilidad ni signos de corrosión. Si encuentra irregularidades, repárelas antes de usar el sistema.
- Nunca juegue con un equipo dañado.
- No use el sistema para levantar ningún objeto. El mecanismo está diseñado para elevar solamente el peso del tablero con el aro. No cuelgue nada de la agarradera, el aro, el tablero ni los brazos de elevación, ya que esto puede dañar el sistema y anular la garantía.

#FS16500 10/12/2004

#### FAUTE DE NE PAS SUIVRE CES AVERTISSEMENTS, VOUS RISQUEZ DE CAUSER DES BLESSURES GRAVES ET/OU DES DOMMAGES À L'ÉQUIPEMENT.

Le propriétaire doit s'assurer que tous les joueurs connaissent et appliquent les règles suivantes afin d'utiliser l'équipement en toute sécurité.

- Ne vous suspendez pas à l'anneau plus que nécessaire pour retrouver votre équilibre ou éviter de blesser les autres joueurs. Relâchez l'anneau aussitôt que possible.
- Lors d'un match, particulièrement dans le cas des smashes, le visage du joueur ne doit pas faire face au panneau, à l'anneau, ni au filet. Le joueur risque de graves blessures si ses dents ou son visage entrent en contact avec le panneau, l'anneau, ou le filet. Les joueurs doivent toujours porter un protège-dents lorsqu'ils jouent.
- Ne glissez pas, ne grimpez pas, et ne jouez pas sur la base ou le poteau.
- Lorsque vous ajustez la hauteur ou l'équipement, gardez vos mains et doigts loin des pièces mobiles.
- N'autorisez pas les enfants à ajuster l'équipement.
- Ne portez pas de bijoux (bagues, montres, colliers, etc.) lorsque vous jouez. Ces objets pourraient s'accrocher au filet.
- Gardez la base du poteau libre de toute matière organique. L'herbe, les déchets, etc. peuvent la corroder et la détériorer.
- Une fois par mois, vérifiez que le poteau et toutes les pièces en métal ne montrent pas de signes de corrosion (rouille, piqûres, écaillage). Enlevez toute la rouille et repeignez complètement avec une peinture pour extérieur. Si la rouille a pénétré une des pièces en acier, vous devrez remplacer immédiatement la pièce en question.
- A chaque fois que vous allez utiliser l'équipement, vérifiez d'abord l'équilibre, la possibilité de pièces desserrées ou usées, la stabilité de l'équipement et tout signe de corrosion ou réparation nécessaire avant utilisation.
- Ne jouez jamais avec un équipement endommagé.
- N'utilisez pas l'équipement pour lever ou soulever quoique ce soit. Son mécanisme a été conçu uniquement pour soutenir le poids du panneau et de l'anneau. N'accrochez rien au manche, à l'anneau, au panneau ni aux leviers sous peine d'endommager l'équipement et d'annuler la garantie.

[www.lifetime.com](http://www.lifetime.com)



## NOTES



## NOTES





## 5-YEAR LIMITED FACTORY WARRANTY

### THE MANUFACTURER RESERVES THE RIGHT TO MAKE SUBSTITUTIONS TO WARRANTY CLAIMS IF PARTS ARE UNAVAILABLE OR OBSOLETE.

1. Lifetime basketball systems are warranted to the original purchaser to be free from defects in material or workmanship for a period of five years from the date of original retail purchase. The word “defects” is defined as imperfections that impair the use of the product. Defects resulting from misuse, abuse or negligence will void this warranty. This warranty does not cover defects due to improper installation, alteration or accident. This warranty does not cover damage caused by vandalism, rusting, “acts of nature” or any other event beyond the control of the manufacturer.
2. This warranty is nontransferable and is expressly limited to the repair or replacement of defective product. If the product is defective within the terms of this warranty, Lifetime Products, Inc. will repair or replace defective parts at no cost to the purchaser. Shipping charges to and from the factory or distribution center are not covered and are the responsibility of the purchaser. Labor charges and related expenses for removal, installation or replacement of the basketball system or its components are not covered under this warranty.
3. This warranty does not cover scratching or scuffing of the product that may result from normal usage. In addition, defects resulting from intentional damage, negligence, unreasonable use or hanging from the rim will void this warranty.
4. Liability for incidental or consequential damages is excluded to the extent permitted by law. While every attempt is made to embody the highest degree of safety in all equipment, freedom from injury cannot be guaranteed. The user assumes all risk of injury resulting from the use of this product. All merchandise is sold on this condition, and no representative of the company may waive or change this policy.
5. This product is not intended for institutional or commercial use; Lifetime Products, Inc. does not assume any liability for such use. Institutional or commercial use will void the warranty.
6. Our goods come with guarantees that cannot be excluded under the Australian Consumer Law. You are entitled to a replacement or refund for a major failure and for compensation for any other reasonably foreseeable loss or damage. You are also entitled to have the goods repaired or replaced if the goods fail to be of acceptable quality and the failure does not amount to a major failure.
7. This warranty is expressly in lieu of all other warranties, expressed or implied, including warranties of merchantability or fitness for use to extent permitted by Federal and state law. Neither Lifetime Products, Inc., nor any representative assumes any other liability in connection with this product. This warranty gives you specific legal rights, and you may also have other rights which vary from state to state.

### PLEASE INCLUDE YOUR DATED SALES RECEIPT AND PHOTOGRAPHS OF DAMAGED PARTS.

REPORT PRODUCT DEFECTS IN WRITING TO:

Lifetime Products, Inc., PO Box 160010 Clearfield, UT 84016-0010  
or call 1-800-225-3865 M-F 7 a.m. to 5 p.m. MST.

### REGISTER YOUR PRODUCT FOR QUICKER CUSTOMER SERVICE.

Visit [www.lifetime.com](http://www.lifetime.com) or call 1-800-225-3865 to register your product today.

### FOR INTERNATIONAL WARRANTY CLAIMS:

All warranty claims must be accompanied by a sales receipt. Report all warranty claims in writing to your regional sales support representative. Please include your dated sales receipt and photographs of damaged parts.

To identify the representative for your region, please visit: [www.lifetime.com/international](http://www.lifetime.com/international)



[www.lifetime.com](http://www.lifetime.com)

**ENHANCE YOUR LIFETIME® PURCHASE BY ADDING ACCESSORIES OR OTHER GREAT PRODUCTS**

*To purchase accessories or other Lifetime® products, visit us at:*

***www.lifetime.com***

*Or call: 1-800-424-3865*

*7:00 am–5:00 pm (M–F) MST and 9:00 am–1:00 pm Saturday MST*

**AMÉLIOREZ VOTRE ACHAT LIFETIME® EN AJOUTANT DES ACCESSOIRES OU DES AUTRES PRODUITS**

*Pour acheter des accessoires ou des autres produits Lifetime®, rendez-vous une visite à :*

***www.lifetime.com***

*Ou appelez-nous au 1-800-424-3865*

*Du lundi au vendredi 7 h – 17 h (HNR) et samedi 9 h – 13 h (HNR)*

**MEJORE SU COMPRA LIFETIME® Y AÑADA ACCESORIOS U OTROS PRODUCTOS EXCELENTES**

*Para comprar accesorios u otros productos Lifetime® EUA, visítenos en:*

***www.lifetime.com***

*O llame al: 1.800.424.3865*

*De lunes hasta viernes 7:00 h–17:00 h (HNR) y sábado 9:00 h–13:00 h (HNR)*



**www.lifetime.com**

