

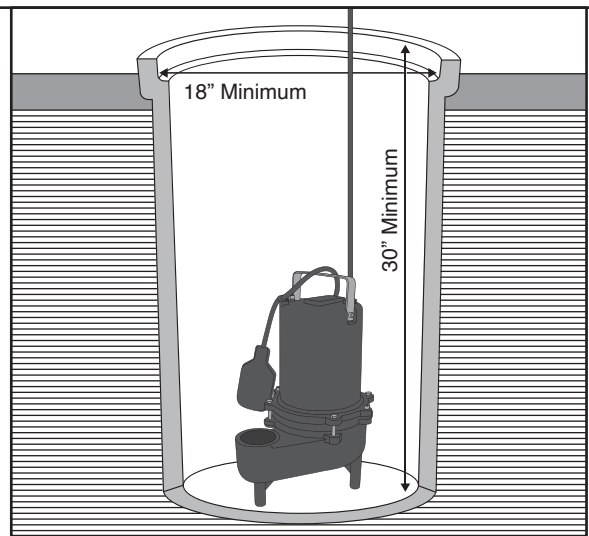

Sewage Pump

Quick Reference Guide

See instruction manual for complete instructional details.



1. Ensure basin is clear of all debris and place pump on hard level surface (not dirt or gravel). 30" x 18" minimum basin requirement.

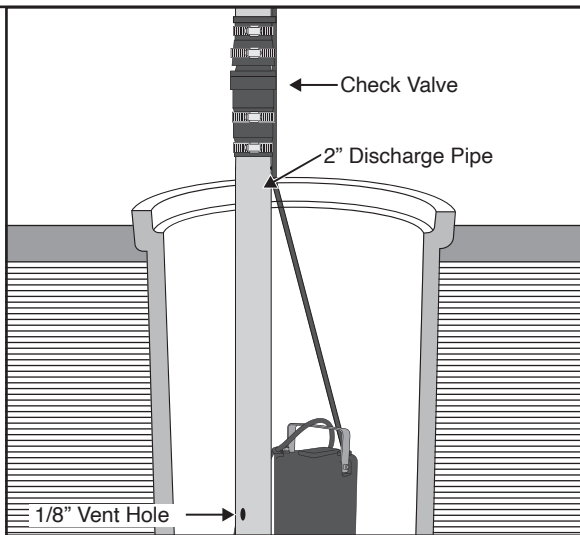

2. Measure, cut and install discharge fittings, check valve, and piping. Drill a 1/8" hole in the discharge pipe about 2"-3" above the pump discharge connection.

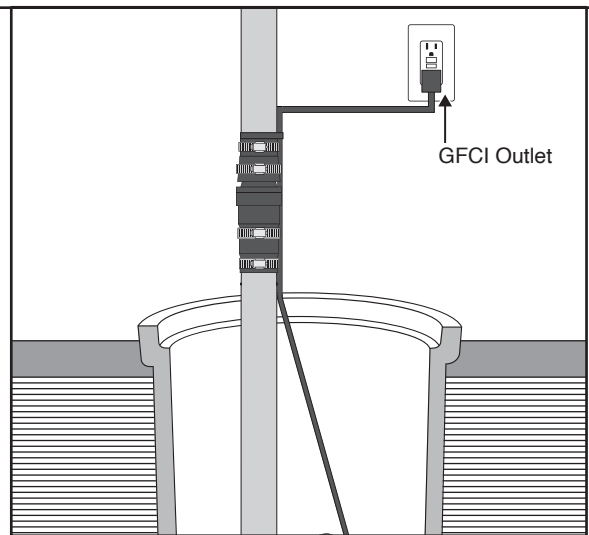

3. Plug Pump in to GFCI outlet on dedicated circuit with 15 amp breaker

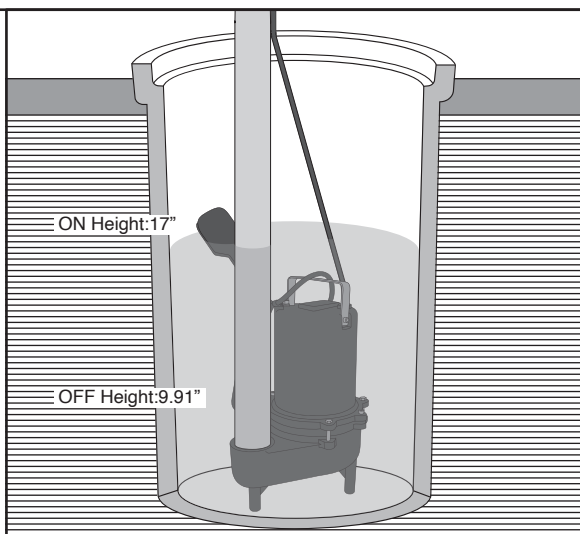

4. Test operation by filling the basin above the Float Switch Operation ON Height to make the pump start pumping out. When the water reaches below the Float Switch Operation OFF Height, ensure it stops pumping.

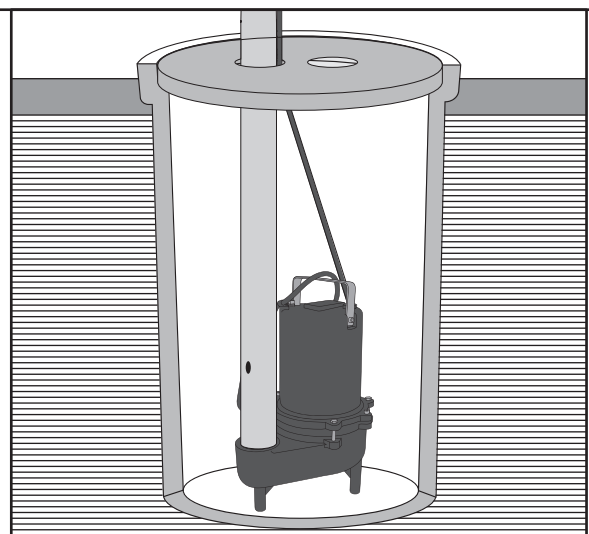

5. Install basin cover.