

CONTINUOUS SOFFIT VENT INSTALLATION INSTRUCTIONS

Model SV201 & SV351

Requires two cuts in soffit for installation. Correct location is as close as practicable to fascia. For new construction or for installation on existing structures.

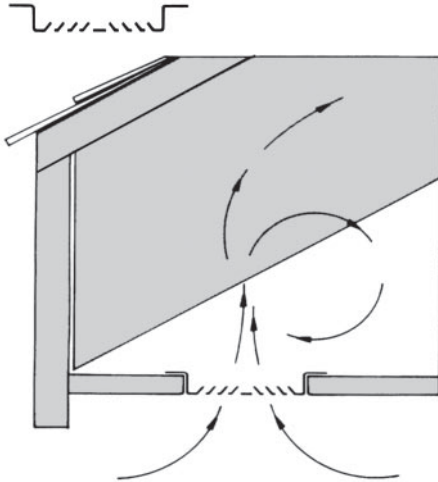

MODEL SV202 & SV352

Installs next to the fascia with only one cut in the soffit required for installation. Vertical flange fits against rafter ends (fascia goes over flange), assuring that the vent will be positioned correctly along outer edge of the soffit. For new construction only – or remodeling involving replacement of fascia.

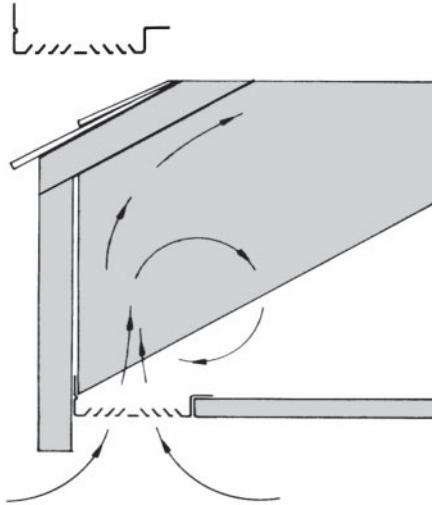

Continuous Soffit Vent always installs correctly, since arrangement of louvers is same from either side. Intake airflow from each side meets above vent to create gentle turbulence assisting fallout of snow and rain before it is carried to insulation.

SPECIFICATIONS

Part	Model	Length	Net Free Area Per Lin. Ft.	Units/Ctn.	Material	Color
84300	SV201 MF	8'	9 sq. in.	50	.014" alum.	mill finish
84302	SV201 WH	8'	9 sq. in.	50	.014" alum.	white
84304	SV201 BR	8'	9 sq. in.	50	.014" alum.	brown
84306	SV202 MF	8'	9 sq. in.	50	.014" alum.	mill finish
84307	SV202 WH	8'	9 sq. in.	50	.014" alum.	white
84308	SV202 BR	8'	9 sq. in.	50	.014" alum.	brown
90320	SV351 WH	8'	9 sq. in.	50	vinyl	white
90325	SV351 BR	8'	9 sq. in.	50	vinyl	brown
90254	SV352 WH	8'	9 sq. in.	50	vinyl	white

Application procedures and conditions are beyond the control of the manufacturer and/or seller of Continuous Soffit Vent and for this reason neither manufacturer nor seller can be responsible for the failure of the product when not used according to instructions and specifications.



4117 Pinnacle Point Dr, Ste 400, Dallas, TX 75211
 Customer Service: 1-800-247-8368 FAX: 1-800-635-7006
 ventilation@gibraltar1.com • www.airvent.com

Form 14014-8/03

© 2003 Air Vent, Inc.

CONTINUOUS SOFFIT VENT INSTALLATION INSTRUCTIONS

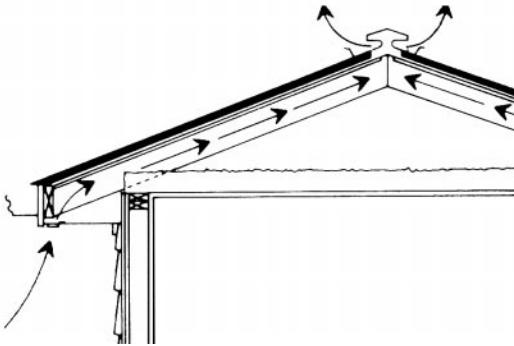

The most effective airflow through the attic space is provided by low intake venting located along the soffit, combined with high venting for exhaust. Research and experience have shown that ridge vents are the ideal high venting, providing a uniform flow of air along the underside of the roof sheathing and along the entire ridge to help prevent summertime heat buildup and wintertime moisture condensation. However, regardless of the type of high vents used, a continuous soffit vent along the outer edge of the eave provides proper air intake.

Continuous Soffit Vent can be combined with all types of high ventilators for a balanced ventilation system. It installs in the soffit as close as practical to the fascia and offers these advantages:

- Continuous Soffit Vent provides a continuous vent opening for uniform distribution of intake air across the underside of the roof sheathing.
- Continuous Soffit Vent keeps infiltrating snow and rain away from ceiling insulation with a special louver pattern. Intake air from half of the louvers is directed toward the flow of air from the other half, creating a gentle turbulence that permits snow and rain to fall out of the air stream onto the vent or adjacent soffit, rather than being carried to the insulation. $1/8"$ louver openings prevent entrance of flies, bees, wasps and other insects – yet are large enough to avoid being clogged by dust and dirt.
- Continuous Soffit Vent installs easily on almost all types of construction.

MODEL SV202 & SV352

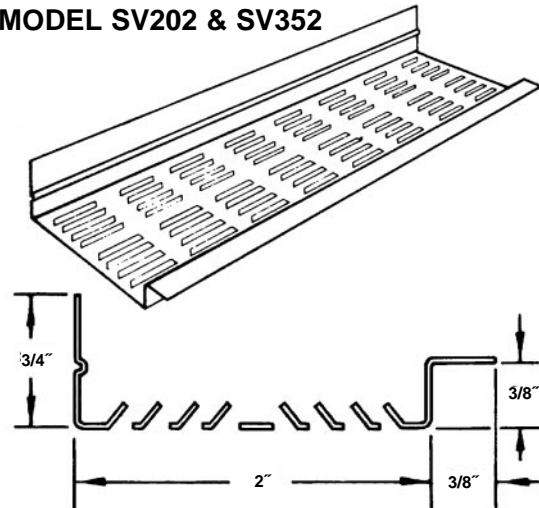

Model SV201 & SV351

