

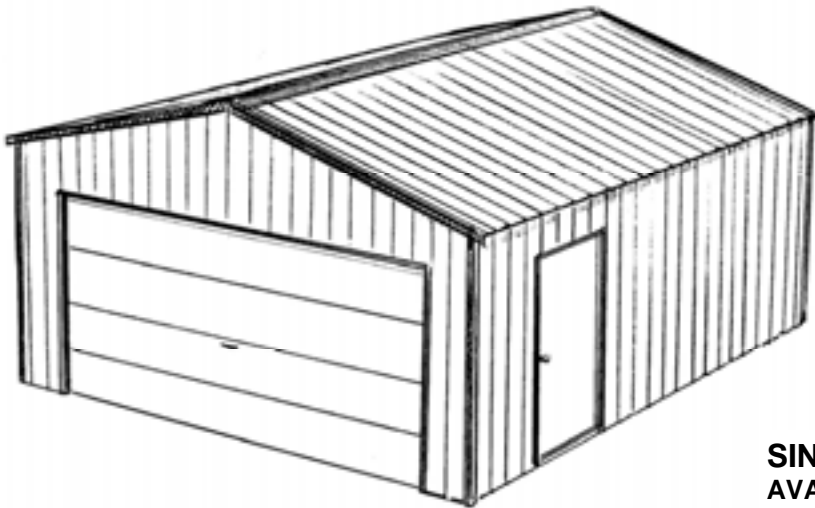

## UNIVERSAL ASSEMBLY INSTRUCTIONS FOR VERSATUBE GARAGE BUILDINGS

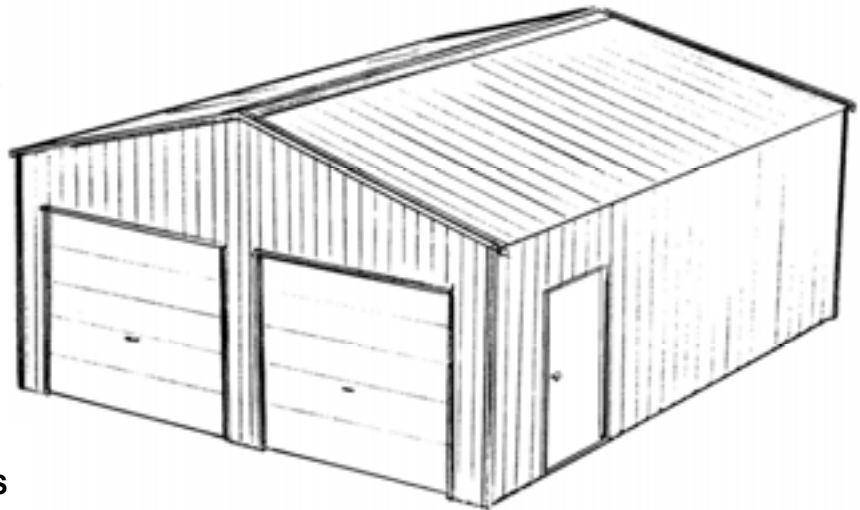

**SINGLE DOOR GARAGE**  
AVAILABLE IN 12', 20', 24' AND 30' WIDTHS



**DOUBLE DOOR GARAGE**  
AVAILABLE IN 24' AND 30' WIDTHS

Our unique assembly process quickly transforms the individual pieces into a finished structure that will give you years of service. Great care has been taken to ensure complete satisfaction with your purchase. In the unlikely event that there are any missing or damaged parts or if you simply need technical assistance, please call our Toll Free Hot-line at 1-800-900-7222 and your questions will be addressed promptly. Thank you for choosing the Versatube Building System.

## ABOUT OUR BUILDINGS:

- Buildings come in four widths: 12', 20', 24', and 30'.
- Buildings come in three side or eave heights: 8', 10', or 12'. Height extensions are required to create 10' and 12' side height buildings — 2' height extensions for 10' and 4' height extensions for 12'.
- Buildings are supplied with 4' or 5' on center post spacing depending on the requirements for wind and snow load in your area of the country.
- The building length will be determined by the number of extension base rails you use. All buildings have starter base rails which are either 8' or 10' with 3 vertical pins. These are installed first on either side at the front of the building. After the starter base rails are in place extension base rails are inserted down the length of the building. These extension base rails will be 8' and 4' for 4' O/C buildings and 10' and 5' for 5' O/C buildings.
- All buildings will have purlins and girts for application of vertical sheet metal.
- The frame layout for the back and front of the building will be different for each building width and height.
- The standard VersaTube® buildings have the following garage door openings: 12' wide (1) 9'x7' door, 20' wide (1) 16'x7' door, 24' wide (1) 16' x 7' door or (2) 9' x 7' doors (optional), and 30' wide (1) 16' x 7' door or (2) 9' x 7' doors (optional). The frame can be adjusted to accommodate taller doors in the same widths. **(Doors not included)**
- A side access or walk door **frame** is provided with each building. **(Door not included)**
- Window frame kits and windows are optional.
- We recommend that your building be anchored to a concrete slab with built-in footings and a sheeting ledge. A foundation drawing is provided for the proper slab construction. The building can also be anchored to a larger, pre-existing slab.

## SAFETY AND HAZARD INSTRUCTIONS

### **IMPORTANT**

Read the following safety warnings and all instructions in their entirety prior to installation. If you have questions or are missing any parts, contact VersaTube Building Systems Customer Service at 1-800-900-7222 before proceeding.

### **WARNING:**

This structure and its manufactured components are engineered per the instructions and engineering plans provided by VersaTube Building Systems. The use of any framing components or materials in the erection of this structure that are not produced or provided by VersaTube could negatively affect the structural integrity and will negate any warranty provisions. VersaTube Building Systems and its authorized dealers are not responsible for any structural collapse or failure to perform resulting from additions, add-ons, or manipulation of non-VersaTube components and/or failure to follow approved instructions.

### **WARNING:**

Metal parts may get hot when exposed to high heat or direct sunlight. Avoid contact with skin and wear protective gloves and clothing to prevent the possibility of burns.

### **WARNING:**

Avoid installation on windy days as wind may create hazards during the installation process. Wind may blow material or cause partially installed components to collapse prior to being secured or fully installed. The weight of the components or structure may cause serious injury if it should collapse.

### **WARNING:**

Metal conducts electricity and electrical shock hazards exist since the structure is made of metal. During installation or storage, keep the structure and all components away from electrical sources. Make sure that your selected location is away from power lines, underground cables, and any other source of electrical power. Serious injury or even death may occur if contact is made with electrical current.

### **WARNING:**

If the structure is moved once it has been installed, be certain to inspect all components and conditions and follow each and every step of these instructions to make certain that the structure is securely anchored, properly installed, and aligned. Failure to follow these steps could lead to collapse of the structure and may result in serious risk of injury.

### **WARNING:**

In the event that your structure is enclosed, be sure to provide proper and adequate ventilation and egress and ingress. Hazardous, poisonous or noxious substances should not be stored in the structure absent proper ventilation and all warnings and instructions of the manufacturer of the substance. Also, proper ingress and egress should be provided to prevent adults or children from becoming trapped inside the structure.

### **WARNING:**

If metal panels are selected to cover all or a portion of your structure, be careful of the sharp edges which may cause cuts or lacerations. Wear protective work gloves and suitable clothing for protection and always take care when handling metal parts. **Always wear safety goggles or glasses when cutting metal or driving/drilling screws.**

# ATTENTION:

**IT IS IMPORTANT THAT YOU READ THE FOLLOWING NOTE BEFORE STARTING THE ASSEMBLY OF YOUR BUILDING**

**NOTE:**



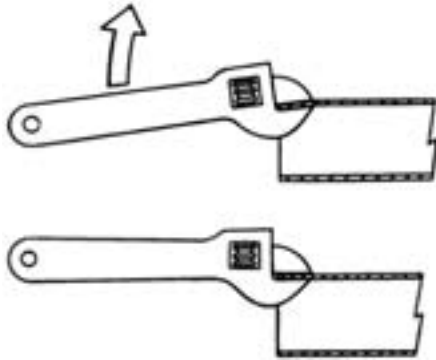

If during the installation process you have difficulty fitting frame components together, use an adjustable wrench to open end of receiving tube as shown below, left. Close wrench down around bent portion of tube and bend wall outward. It may also be helpful to hit the center of the swaged at the end of the tube to create more of a lead.

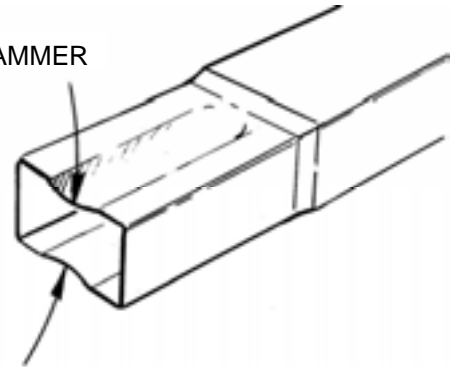

STRIKE WITH HAMMER

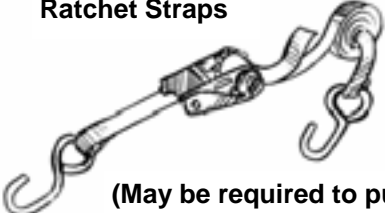

## What you'll need:

<p>Torque Setting Cordless (14 or 18 volt) Or Electric Screw Gun With 5/16" Socket Drive</p> 	<p>Utility Knife</p> 	<p>2 Step Ladders</p> 
<p>Safety Goggles Or glasses</p> 	<p>Hammer Drill</p> 	<p>Masonry Drill Bit 1/2" x 8" Drill depth</p> 
<p>Hammer</p> 	<p>Tape Measure</p> 	<p>Work Gloves</p> 
<p>Hack Saw or Circular saw with Abrasive disk</p> 	<p>Motor Cycle or Ratchet Straps</p>  <p>(May be required to pull frame plumb.)</p>	<p>Level</p> 
<p>Pencil/Marker and Felt Marker</p> 	<p>Wrench, 3/4" &amp; 1/2"</p> 	<p>Tin Snips</p> 
<p>Chalk Line and Mason Line or Nylon String</p> 	<p>Vise grip or other quick clamp</p> 	<p>Aviation Snips</p> 
<p>Adjustable wrench</p> 		

**BASIC PARTS LIST: SIZES AND QUANTITIES WILL VARY BY BUILDING WIDTH AND LENGTH SEE THE PACKING SLIP WITH YOU BUILDING FOR PART NUMBERS AND QUANTITIES.**

10' STARTER BASE RAIL  
Used on buildings with 5' on center post spacing



10' BASE EXTENSION RAIL  
Used on buildings with 5' on center post spacing



5' BASE EXTENSION RAIL  
Used on buildings with 5' on center post spacing



8' STARTER BASE RAIL  
Used on buildings with 4' on center post spacing



8' BASE EXTENSION RAIL  
Used on buildings with 4' on center post spacing



4' BASE EXTENSION RAIL  
Used on buildings with 4' on center post spacing



HEIGHT EXTENSION



2X2 VERTICAL EXTENSION



2X2 BACK/FRONT BASE RAIL



2X2 VERTICAL HEADER BRACE



GARAGE DOOR HEADER, 2X3, SWAGED END.



BACK VERTICAL 2X2X81 3/4" SWAGED ONE END



TRUSS BRACE END TIE 2" X 2"



TRUSS BRACE CENTER TIE 2" X 2" SWAGED BOTH ENDS



HAT CHANNEL (ROOF AND SIDES) 4', 5', 8', or 10' LENGTH.



FRONT & BACK GIRTS 1 1/2 SQUARE



INSIDE CLOSURE



OUTSIDE CLOSURE



PEAK



SIDE POST



RAFTER



T-CONNECTOR

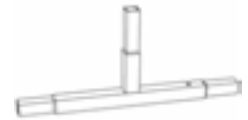

L-CONNECTOR



COLLAR TIE BRACKET LEFT AND RIGHT

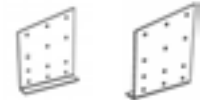

ANGLE BRACKET



FLAT BRACKET



SINGLE PURLIN BRACKET



DOUBLE PURLIN BRACKET



BUTYL SEALING TAPE



#12 SELF-DRILLING



#10 PAN HEAD, SELF-DRILLING SCREW



1" SELF-DRILLING SCREW WITH WASHER, PAINTED



1/2" x 7" CONCRETE WEDGE ANCHOR

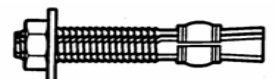

PARTS NOT SHOWN ARE 2X3 OR 2X2 STRAIGHT LENGTH PARTS. SHEET METAL AND TRIM ARE SHOWN IN THAT SECTION.

**STEP 1: FOUNDATION** CHECK WITH YOUR LOCAL BUILDING OFFICIAL BEFORE YOU POUR A SLAB OR ANCHOR YOUR BUILDING.

We recommend that you have a concrete slab poured as a foundation for your building. A foundation drawing is included with the assembly instructions. If you choose to mount the building to an existing slab, the slab should be larger than the outside building dimensions by at least 3" front to back and 6" side to side.

**STEP 2: BASE RAIL ASSEMBLY**

Place the starter base rails in the front corners of the building 1 1/2" in from the sheeting ledge on the sides of the slab. (See FRONT DETAIL below) The outside dimension of the base rails should be your building width (12', 20', 24', or 30') The starter base rails are either 8'-2" or 10'-2" long with 3 welded vertical pins. The 8'-2" rails are for 4' on center buildings and the 10'-2" rails are for 5' on center buildings.

Now, insert 8' or 10' length extension base rails into the starter base rails as shown until you get to the desired building length. NOTE: the last base rails that you insert to get to your building length may be 4' or 5' base extensions.

The vertical pins should be on 4' or 5' centers. Measure the distance from the end pin on each base rail to the first pin on the next inserted base rail and adjust the joint so that all the pins are on 4' or 5' centers. (46" or 58" between pins) HINT: IT may be helpful to cut a spacer board 46" or 58" to use as a guide for pin spacing. When you are sure that you have all the base rails in the proper location, fasten each joint with two #12 self-drilling screws on the top of the base rail.

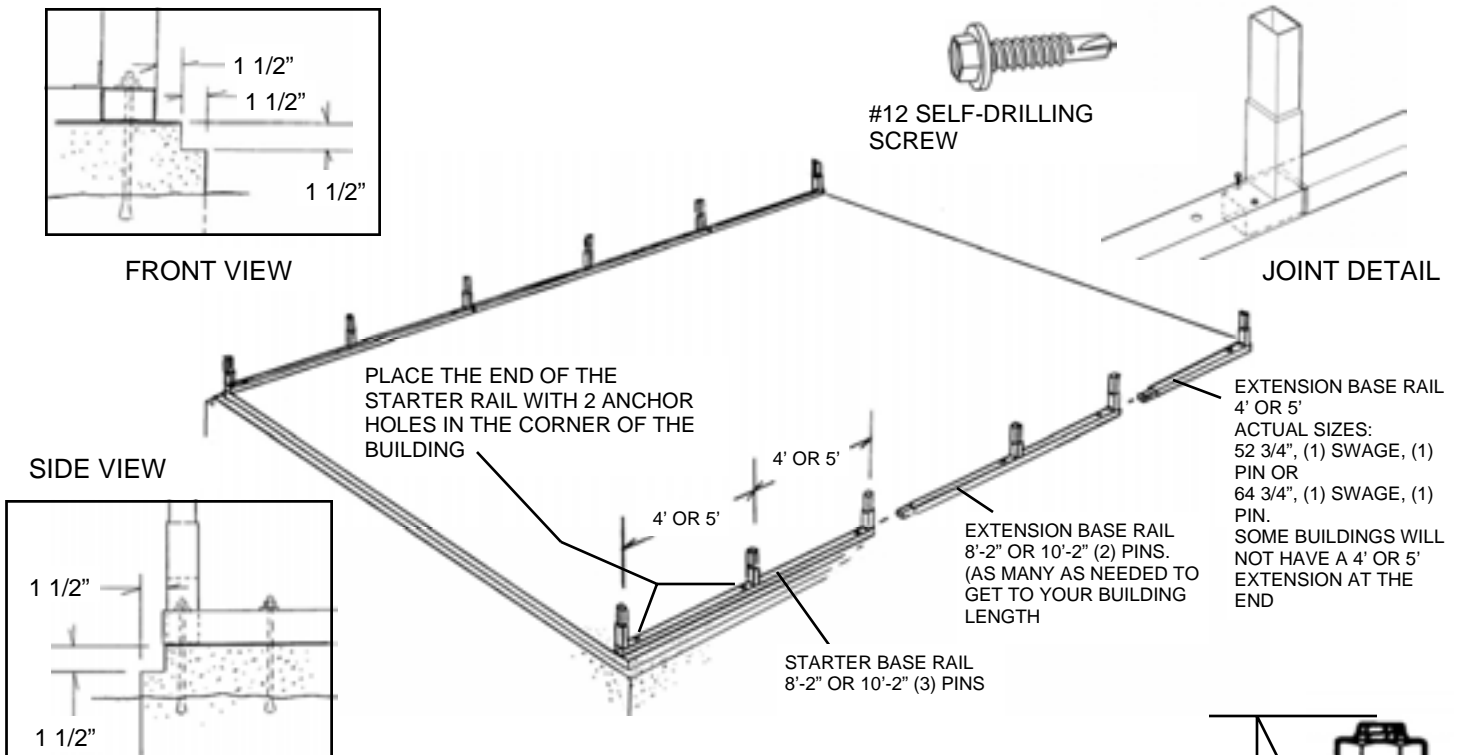

**ANCHORING THE BASE RAILS:**

Check with your local building official to see if concrete expansion bolts are acceptable in your area. Some regions may require adhesive anchors. We recommend 1/2" x 7" expansion anchors with a 1/2" flat washer.

**INSTALLATION:**

Use a 1/2" concrete bit in a hammer drill to drill a 5" deep hole in the slab. Use the anchor hole in the tube as a guide. Place the washer and nut on the top of the bolt with about 2 threads showing. Tap the bolt into the hole with a hammer and tighten the nut until it is good and snug. Do not crush the base rail tube.

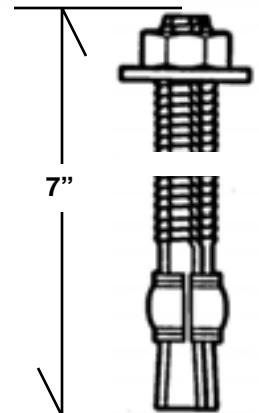
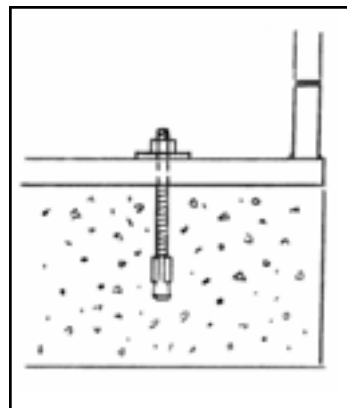

### STEP 3: ROOF/WALL FRAME ASSEMBLY

On the ground, assemble (1) peak, (2) rafters, (2) side posts, and (2) height extensions if required. (10' or 12' side height buildings require 2' or 4' height extensions.)

Before you fasten the joints with screws take a measurement across the top and bottom of the assembly as shown. This outside measurement is the outside size of your building. (12', 20', 24', or 30') Try to keep the joint spacing on both sides of the assembly equal. **It is very helpful to drive stakes into the ground at the width of the building and use them to set the dimension at the bottom of the assembly. You should set the bottom dimension before you adjust and set the top dimension.**

Now, fasten the joints with #12 self-drilling screws. 4 screws in the peak to rafter and side post to rafter joints and 2 screws in the height extension joints. See details below.

NOTE: You can use the first assembly as a template to assemble the remaining Roof/Wall Frames.

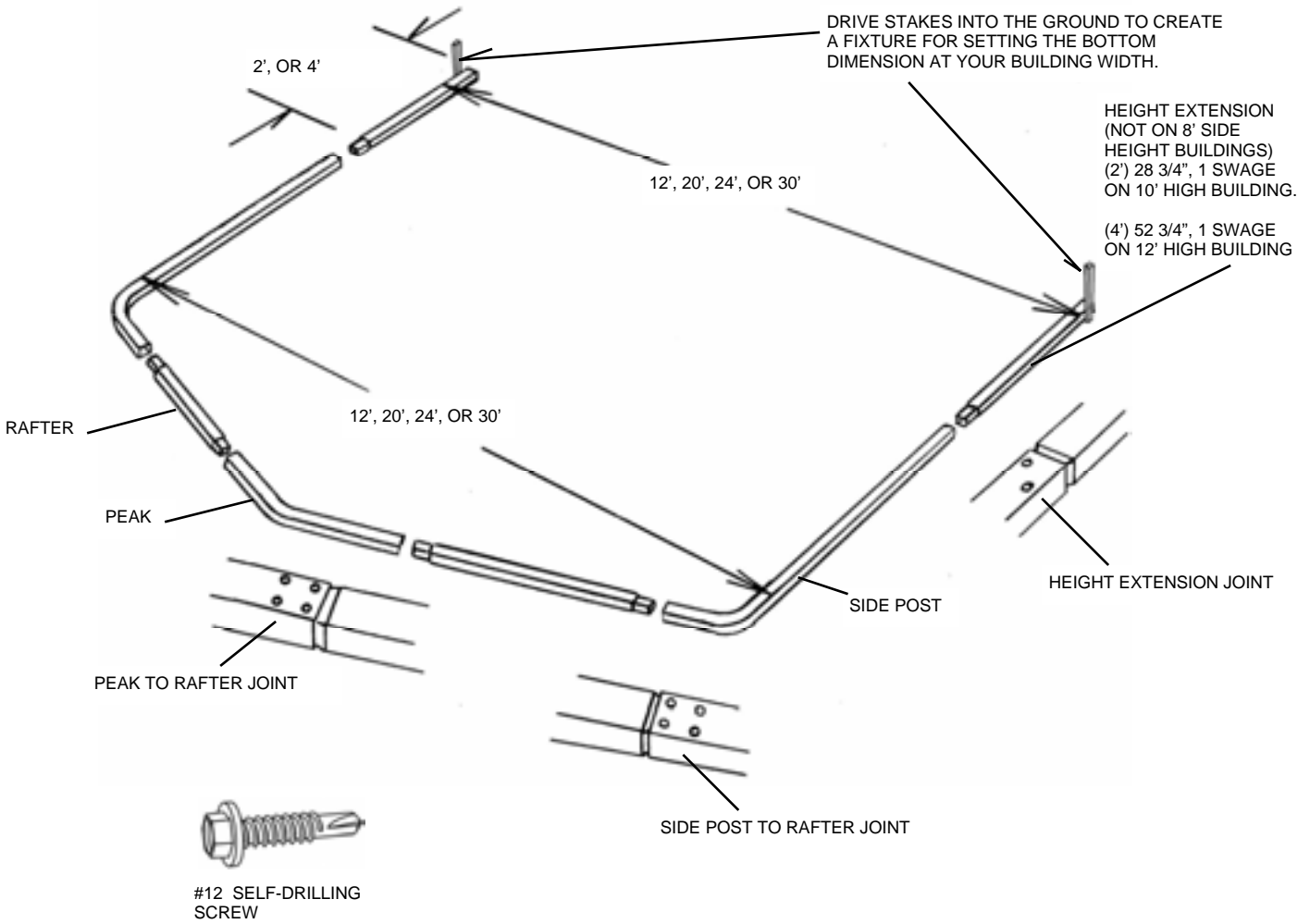

**BRACING:**

**TYPE (1) COLLAR TIE, TYPE (2) COLLAR TIE WITH VERTICAL, TYPE (3) COLLAR TIE WITH WEB BRACES**

Bracing on buildings is determined by the width of the building and the wind and snow load in your county. 12' wide buildings do not normally require a truss brace. 20' wide buildings may or may not require a brace. 24' and 30' wide buildings always require a truss brace.

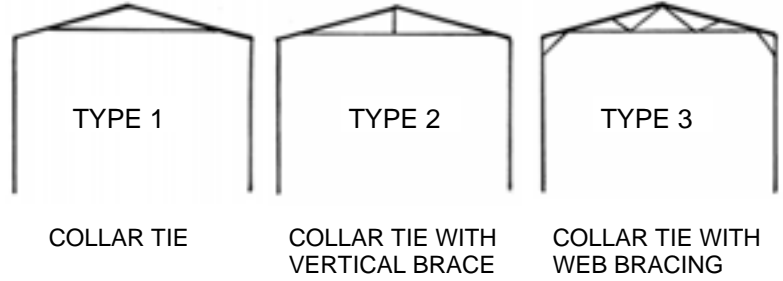

**COLLAR TIE ASSEMBLY:**

The Collar Tie (Type 1 brace) for a 12' wide building, if required, is one piece 2" x 2" x 96" long. All other Collar Ties are made up of 3 parts: (1) Center Tie 2" x 2" x 111" long swaged (reduced) on both ends and (2) end ties. End Ties are 2" square tube. On 20' wide buildings 50 1/2" long. On 24' wide buildings 74 1/2" long. On 30' wide buildings 111" long.

Assembly: Place an End Tie on both ends of the Center tie and fasten each joint with (6) #12 self-drilling screws. Place screws on one side of the assembly as shown. Note: make sure the assembly is straight when you install screws.

Install a left and right Collar Tie Bracket on both ends as shown. Use one screw in each hole.

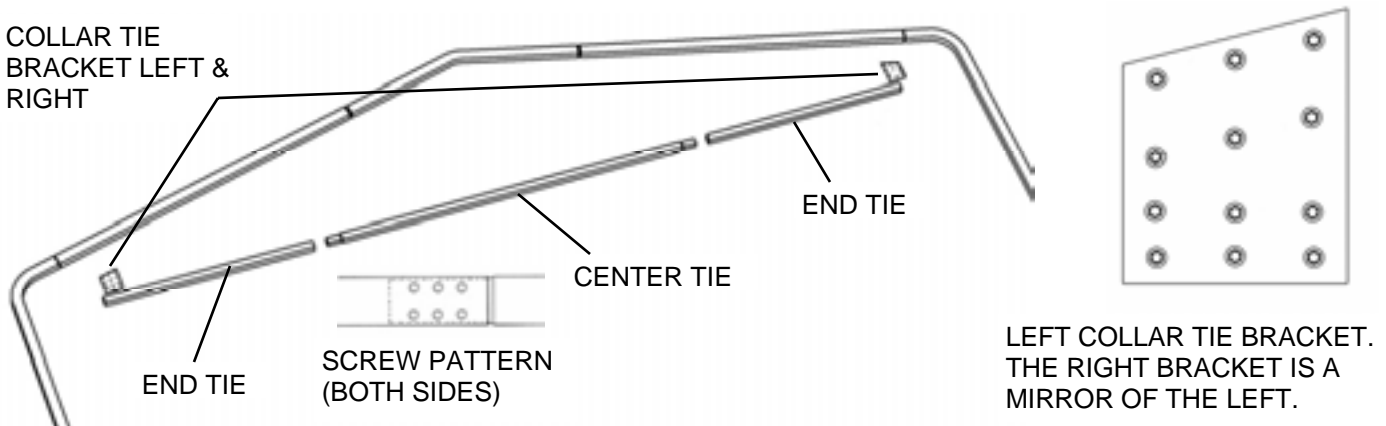

**ASSEMBLY OF COLLAR TIE TO ROOF/WALL FRAME:**

The collar tie must be centered in the frame. Take a measurement from the end of the side post to the edge of the collar tie bracket on both ends of the collar tie. Adjust the collar tie side to side until the measurements are equal. Fasten with (6) self-drilling screws on each side of the assembly.

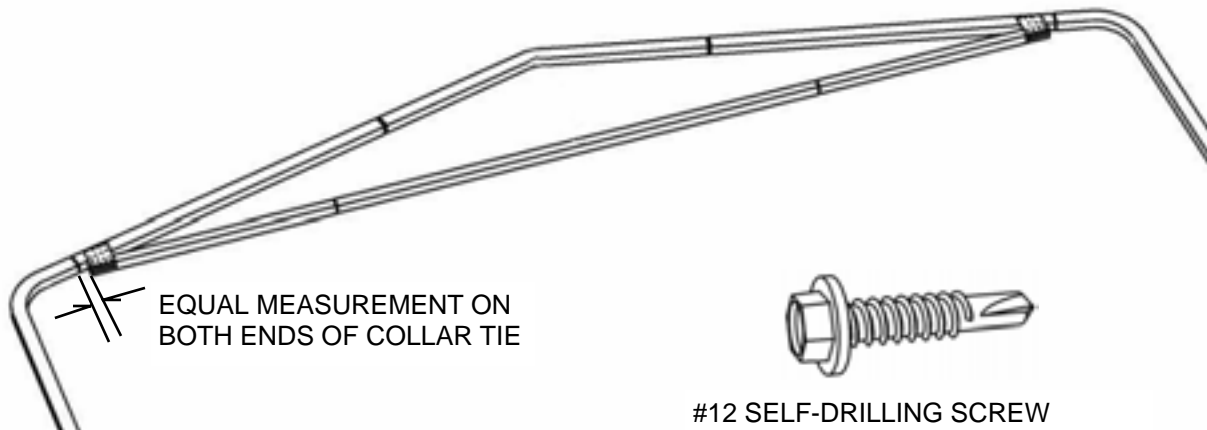

## INSTALLING VERTICAL BRACE FOR BRACE TYPE (2)

The Center Vertical Brace is 1 1/2" square x 25 1/4" long on 20' wide buildings, 31 1/4" long on 24' wide, and 40 1/4" long on 30' wide. Fasten the brace to the Collar Tie and the Frame Peak with Single Purlin Brackets. Use two screws in the bracket tongue and one screw in each side flange as shown. Fasten the brackets to the vertical brace first. Make sure that the Collar Tie assembly is straight before you fasten the brace to the Collar Tie and Peak. Place all parts in the assembly and adjust before installing any screws.

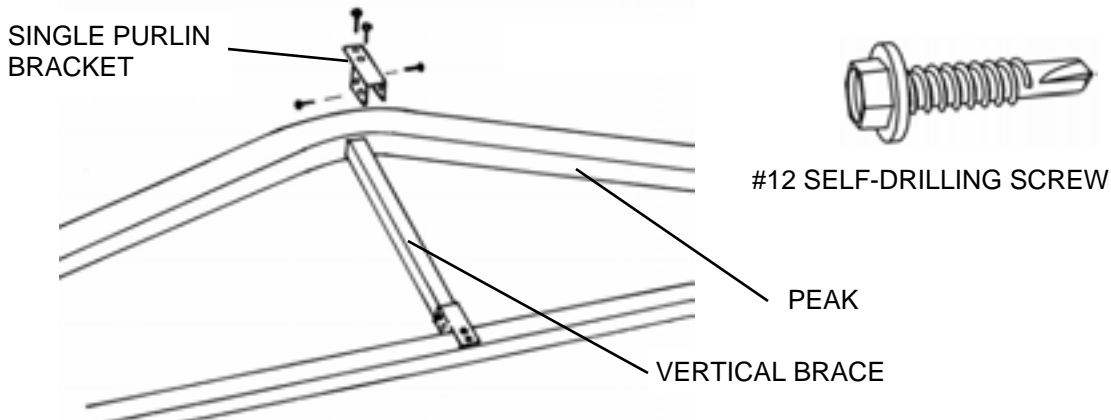

## ASSEMBLING WEB BRACING:

### STEP 1: INSTALLING THE PEAK WEB BRACKET.

Measure up from both ends of the peak to find the center and make a mark. Place a Web Bracket centered at your mark and pressed against the bottom of the peak. Fasten the Bracket to the peak with 3 self-drilling screws as shown in detail.

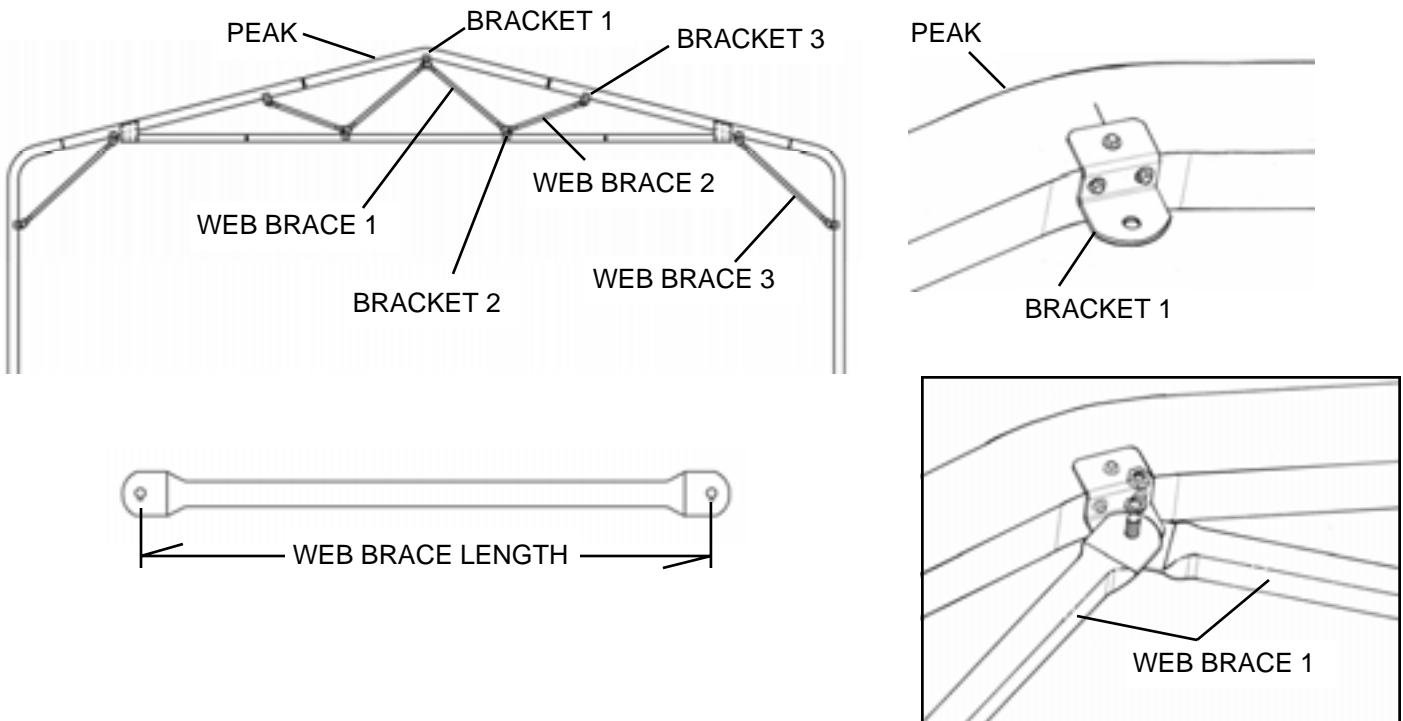

STEP 2: INSTALL TWO OF WEB BRACE 1: (On 20' wide building 36" long, On 24' wide building 46" long and on 30' wide building 60" long) Place one of the brace ends on top of the Web Bracket tab and the other brace end on the bottom of the tab. Join the parts with a 3/8" x 1 1/4" hex bolt, lock washer and hex nut. Do not tighten at this time. It may be necessary to lift the frame to insert bolt.



STEP 3: INSTALL WEB BRACE 2: (On 20' buildings 24") (On 24' buildings 30") (On 30' wide buildings 36") Loosely attach Web Bracket 2 to the other end of Web Brace 1. Place the Web Bracket on the Collar Tie (make sure the collar tie is straight and fasten the face of the bracket to the collar tie with a self-drilling screw. Remove the hex nut and attach one end of Web Brace 2 to the Web Bracket 2 assembly. ( like the first assembly, one brace end should be on one side of the web bracket tab and one on the other.) Now, Loosely attach Web Bracket 3 to the other end of Web Brace 2 and fasten the bracket to the under side of the rafter. Repeat assembly for remaining Web Brace 2.

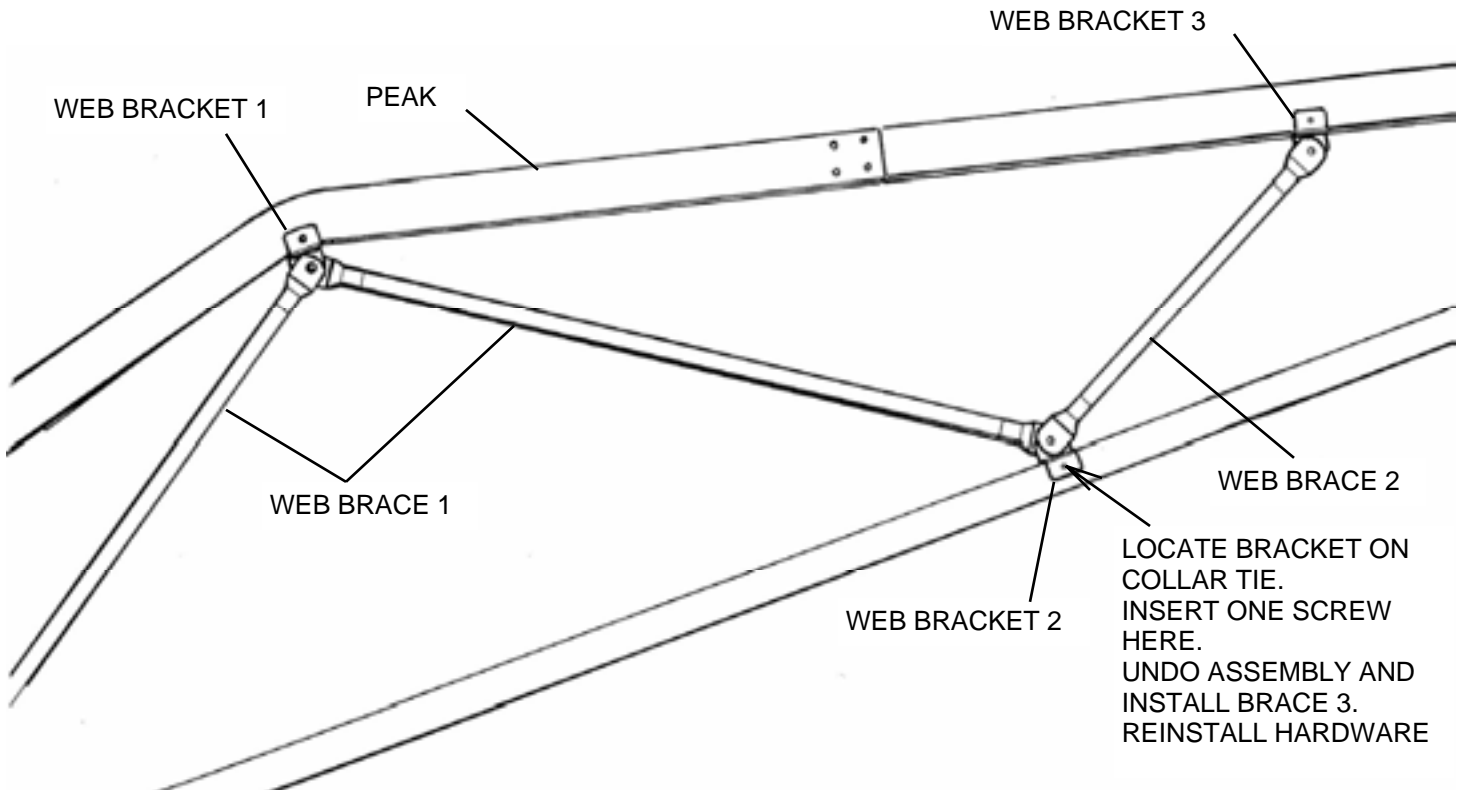

STEP 4: ASSEMBLING WEB BRACE 3: WEB BRACE 3 IS 24" LONG ON ALL BUILDINGS. Measure out 1" from the end of the Collar Tie and make a mark. This will be the location of the upper Web Bracket for Web Brace 3. Attach the upper Web Bracket with 3 self-drilling screws. Now, fasten Web Brace 3 to the upper Web Bracket with a hex bolt, lock washer and hex nut. (Do not tighten at this time) Loosely attach a Web Bracket to the lower end of Web Brace 3 and place it against the side post. Re-check the building dimension across the bottom of the frame 20', 24', or 30' before attaching lower bracket to side post. Now, attach the face to the side post with a screw, remove the hex nut, let the bolt drop down and install the two screws in the side of the Web Bracket. Now, reinstall the bolt, lock washer and nut. Repeat assembly for remaining Web Brace 3 on the other side of the frame.

WHEN ALL BRACES ARE IN PLACE, TIGHTEN ALL HARDWARE. The nut size is 9/16". You may also need to hold the bolt head with pliers.

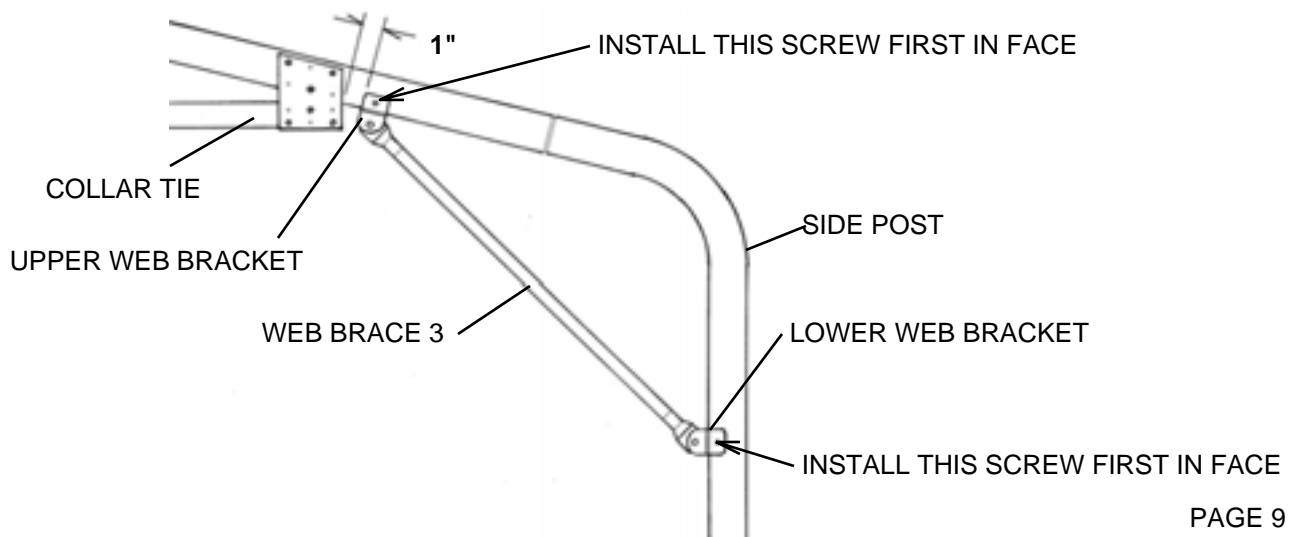

## STEP 4: INSTALLING ROOF/WALL FRAMES TO BASE RAILS

NOTE: This assembly will require at least two people. 24' and 30' frames may require more.

Start at one end of the building and place a Roof/Wall assembly, with no truss brace, on the first base rail vertical pins. Fasten joints with two screws each. Keep the screw heads away from the outside of the building where sheet metal will be installed.

Repeat this assembly until all Roof/Wall assemblies are installed. ( Remember, no Truss Braces at the ends of the building)

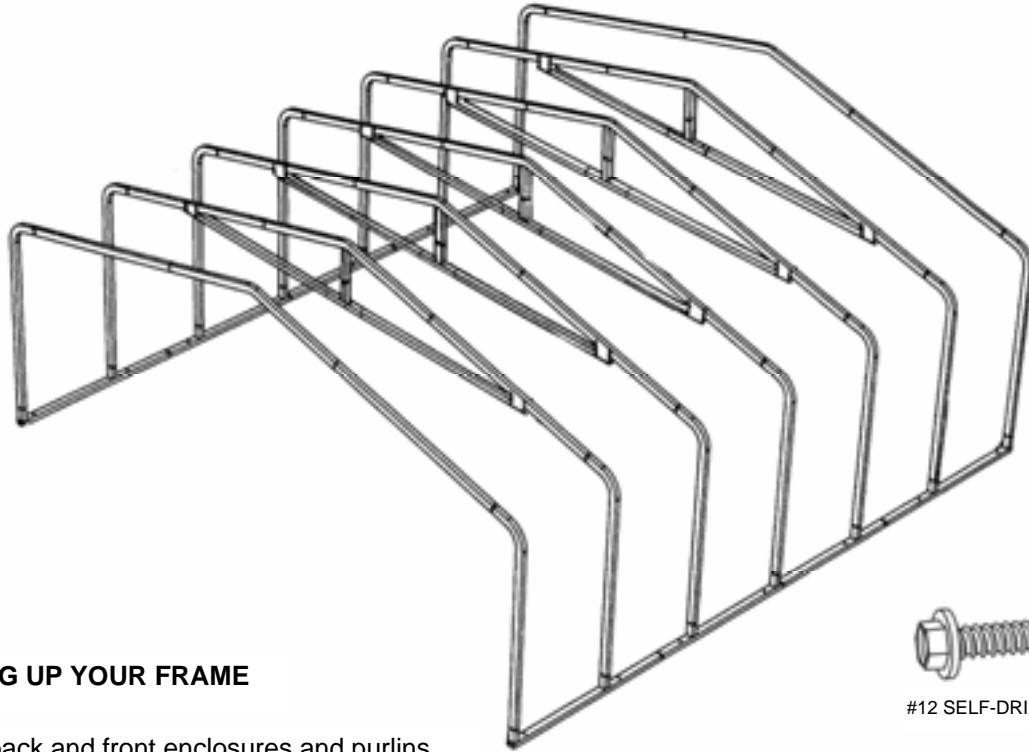

### SQUARING UP YOUR FRAME

Before you install back and front enclosures and purlins and girts, you may want to check the Roof/Wall assemblies to make sure they are plumb and square and that the height of each side post is equal.

To do this, first check the front and back Roof/Wall sections to make sure that they are plumb. Check the outside of the side post. If adjustments must be made, you can drive a wooden or metal stake into the ground about 8' from the building and use a Motor Cycle strap or Ratchet strap to pull the side post into plumb. Place a clamp on the side post as shown and attach the strap above the clamp.

When the front and back sections are plumb (side to side) tie two strings from the front side post to the back side post at the bottom and top of the bend radius as shown. These strings will let you see which sections are high, low or out of plumb. If the side posts are high or low, remove the joint screws and raise the low posts and hammer down the higher posts as much as possible. Reinstall the screws in a new location. Check the height of the side posts on both sides of the building. The straps should remain in place until the roof purlins are installed.

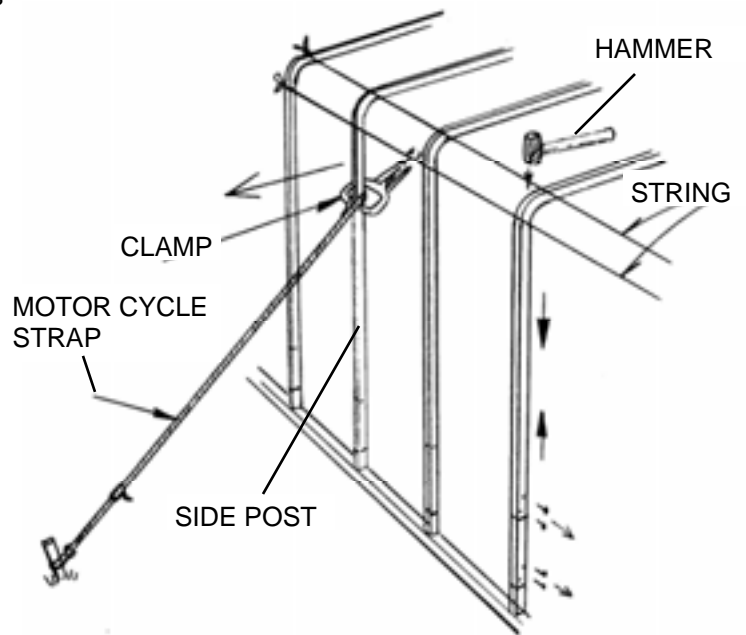

Note: this is not a critical step, but it may improve the appearance of your building. If side posts are out of plane with the other side posts more than 1/4" it may be visible.

## STEP 5: INSTALLING BACK BASE RAILS

The Back Enclosure is the frame components that enclose the back of the building.

Layout the Base Rail components as shown in the illustration of your building size. Note that all back frame components are 2" x 2" square tubing. See illustration below for length dimensions of base rail tubes.

The base rail assembly is made up of straight length 2" square tubes and T-Connectors. When you have all of the base rail assembly together place the assembly between the back side base rails of the building. Fasten the end base rails to the pins of the side base rails with Angle Brackets. The spaces between the vertical pins should be equal. (12' wide building 68" space, 20' wide building 57", 24' wide building 69" and 30' wide building 69 1/4".)

Fasten joints with two 1" self-drilling screws on top of the base rail.

Anchor the T-Connectors to the concrete slab or footing as you did the side base rails with 1/2" x 7" wedge anchors.

## STEP 6: INSTALLING BACK VERTICALS

The Back Vertical is a 2" x 2" x 81 3/4" tube with one swaged (reduced) end. The Vertical Extensions are 2" square tubes. The length is shown in the illustration below.

Join the Back Verticals and the appropriate Vertical Extensions. (do not install screws at this time) Place the assemblies on the base rail pins, plumb the assembly, slide the extension tube up to touch the rafter or peak and attach it with a Flat Bracket on the inside of the building. It may help to attach the flat bracket to the vertical extension before you install the assembly. Let 2" of the bracket extend beyond the end of the extension.

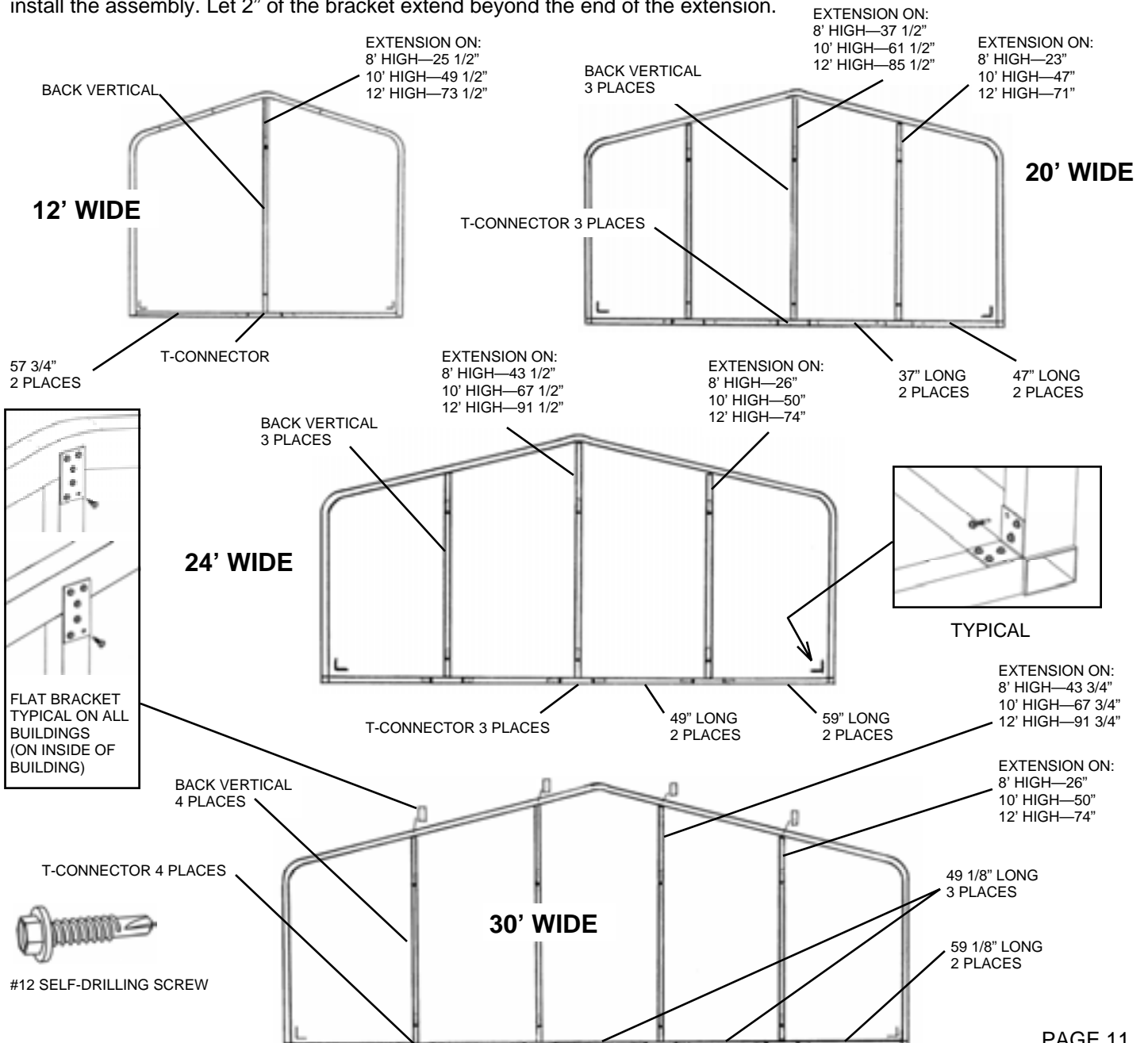

# STEP 7: INSTALLING FRONT BASE RAILS AND VERTICALS

**GARAGE DOORS: THE BASIC GARAGE BUILDING COMES WITH 1 GARAGE (OR OVERHEAD) DOOR OPENING. 24' AND 30' WIDE BUILDINGS CAN ALSO HAVE AN OPTIONAL DOUBLE DOOR OPENING.**  
**DOOR SIZES: 12' Wide-9' Door, 20' Wide-16' Door, 24' Wide-16' or (2) 9' Doors, 30 Wide-16' or (2) 9' Doors**

Find the illustration that matches your building size and door style. Join the Base Rail tubes and (L) or (U) connectors as shown. The Base Rails are all 2" square tubes. See illustration for tube length.  
 Measure and mark the location for the base rails and anchor the L & U connectors with expansion bolts as you did the side base rails. **NOTE: Leave the nuts slightly loose so you can install the vertical tubes. Attach the end base rails to the side base rail pins with Angle brackets as you did on the back base rail ends after the vertical tubes are installed.**  
 The door openings should be 9' wide or 16' wide.

Assemble the Door Vertical Tubes (see drawing for parts and location). Attach a Flat Bracket at the top as shown and stack the vertical Door Jamb tubes on the L-Connectors or U-Connectors as shown. Plumb the Door Jambs and attach the top portion of the assembly to the rafter or peak. Note that the Flat Bracket should be on the inside of the building. Be sure to leave a space between the Door Jambs of 9' or 16' to install the door header.

Assemble the Door Header components as listed in the illustration and fasten them to the Door Jambs with Angle Brackets on the top of the header. The basic garage door header height is 7' you may have chosen to install a taller door. Set the height at the bottom of your door header at 7' or the height of your chosen door.  
 Now, install the vertical Header Brace in the center above the Door Header with 2 Angle Brackets at the bottom and a Flat Bracket at the top on the inside of the building. The brace should be plumb. You may find it easier to attach the brackets to the header brace on the ground (see detail). **(NOTE: If you are installing a taller door than 7' you will need to cut the Vertical Header Brace to fit your door height.)**

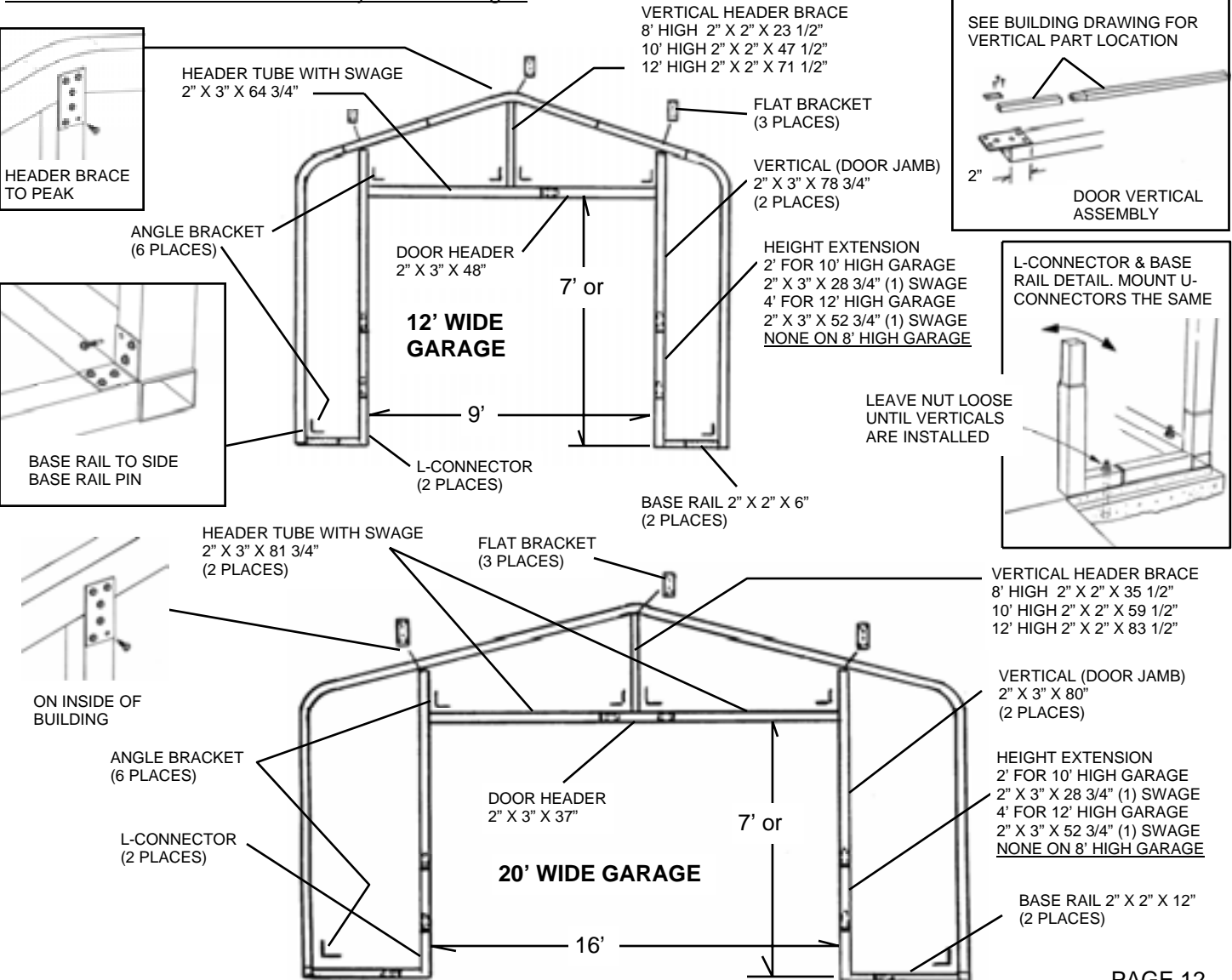

# INSTALLING FRONT ENCLOSURE CONTINUED

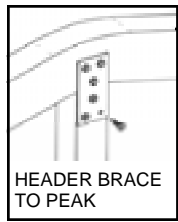

HEADER BRACE TO PEAK

HEADER TUBE WITH ONE END SWAGED  
2" X 3" X 81 3/4"

VERTICAL HEADER BRACE  
8' HIGH 2" X 2" X 41 1/2"  
10' HIGH 2" X 2" X 65 1/2"  
12' HIGH 2" X 2" X 89 1/2"

FLAT BRACKET  
(3 PLACES)

ANGLE BRACKET  
(6 PLACES)

DOOR HEADER  
2" X 3" X 37"

VERTICAL (DOOR JAMB)  
2" X 3" X 86 1/4"  
(2 PLACES)

HEIGHT EXTENSION  
2' FOR 10' HIGH GARAGE  
2" X 3" X 28 3/4" (1) SWAGE  
4' FOR 12' HIGH GARAGE  
2" X 3" X 52 3/4" (1) SWAGE  
NONE ON 8' HIGH GARAGE

7' or

L-CONNECTOR  
(2 PLACES)

## 24' WIDE GARAGE SINGLE DOOR

BASE RAIL 2" X 2" X 36"  
(2 PLACES)

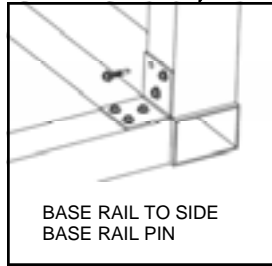

BASE RAIL TO SIDE  
BASE RAIL PIN

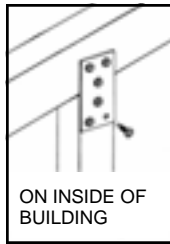

ON INSIDE OF  
BUILDING

FLAT BRACKET  
(3 PLACES)

VERTICAL (DOOR JAMB) EXTENSION  
8' GARAGE 2" X 3" X 30 3/4"  
10' GARAGE 2" X 3" X 54 3/4"  
12' GARAGE 2" X 3" X 78 3/4"  
(2 PLACES)

VERTICAL HEADER BRACE  
8' HIGH 2" X 2" X 25"  
10' HIGH 2" X 2" X 49"  
12' HIGH 2" X 2" X 73"  
(2 PLACES)

ANGLE BRACKET  
(10 PLACES)

DOOR HEADER  
2" X 3" X 48"  
1 ON EACH DOOR

7' or

9'

VERTICAL (DOOR JAMB)  
2" X 3" X 81 3/4" WITH  
SWAGED (REDUCED) END  
(2 PLACES)

U-CONNECTOR

VERTICAL (DOOR JAMB)  
2" X 3" X 80"  
(2 PLACES)

BASE RAIL 2" X 2" X 11 3/4"  
(2 PLACES)

L-CONNECTOR  
(2 PLACES)

HEADER TUBE WITH ONE END SWAGED  
2" X 3" X 64 3/4"  
(1 ON EACH DOOR)

HEIGHT EXTENSION  
2' FOR 10' HIGH GARAGE  
2" X 3" X 28 3/4" (1) SWAGE  
4' FOR 12' HIGH GARAGE  
2" X 3" X 52 3/4" (1) SWAGE  
NONE ON 8' HIGH GARAGE

## 24' WIDE GARAGE DOUBLE DOOR

# INSTALLING FRONT ENCLOSURE CONTINUED

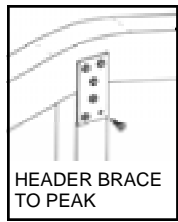

HEADER BRACE TO PEAK

HEADER TUBE WITH ONE END SWAGED  
2" X 3" X 81 3/4"

VERTICAL HEADER BRACE  
8' HIGH 2" X 2" X 50 1/2"  
10' HIGH 2" X 2" X 74 1/2"  
12' HIGH 2" X 2" X 98 1/2"

FLAT BRACKET  
(3 PLACES)

ANGLE BRACKET  
(6 PLACES)

DOOR HEADER  
2" X 3" X 37"

VERTICAL (DOOR JAMB)  
2" X 3" X 95"  
(2 PLACES)

HEIGHT EXTENSION  
2' FOR 10' HIGH GARAGE  
2" X 3" X 28 3/4" (1) SWAGE  
4' FOR 12' HIGH GARAGE  
2" X 3" X 52 3/4" (1) SWAGE  
NONE ON 8' HIGH GARAGE

7' or

16'

L-CONNECTOR  
(2 PLACES)

## 30' WIDE GARAGE SINGLE DOOR

BASE RAIL 2" X 2" X 72"  
(2 PLACES)

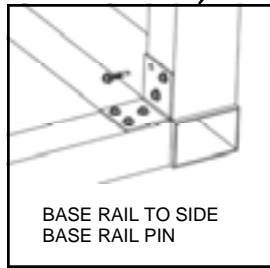

BASE RAIL TO SIDE  
BASE RAIL PIN

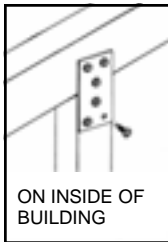

ON INSIDE OF  
BUILDING

FLAT BRACKET  
(3 PLACES)

VERTICAL (DOOR JAMB) EXTENSION  
8' GARAGE 2" X 3" X 36 5/8"  
10' GARAGE 2" X 3" X 60 5/8"  
12' GARAGE 2" X 3" X 84 5/8"  
(2 PLACES)

VERTICAL HEADER BRACE  
8' HIGH 2" X 2" X 31 1/4"  
10' HIGH 2" X 2" X 55 1/4"  
12' HIGH 2" X 2" X 79 1/4"  
(2 PLACES)

ANGLE BRACKET  
(10 PLACES)

DOOR HEADER  
2" X 3" X 48"  
1 ON EACH DOOR

7' or

9'

VERTICAL (DOOR JAMB)  
2" X 3" X 81 3/4" WITH  
SWAGED (REDUCED) END  
(2 PLACES)

VERTICAL (DOOR JAMB)  
2" X 3" X 86 1/4"  
(2 PLACES)

BASE RAIL 2" X 2" X 35 3/4"  
(2 PLACES)

BASE RAIL  
2" X 2" X 29 3/4"

HEIGHT EXTENSION  
2' FOR 10' HIGH GARAGE  
2" X 3" X 28 3/4" (1) SWAGE  
4' FOR 12' HIGH GARAGE  
2" X 3" X 52 3/4" (1) SWAGE  
NONE ON 8' HIGH GARAGE

L-CONNECTOR  
(2 PLACES)

HEADER TUBE WITH ONE END SWAGED  
2" X 3" X 64 3/4"  
(1 ON EACH DOOR)

## 30' WIDE GARAGE DOUBLE DOOR

## STEP 8: ASSEMBLE SIDE WALK DOOR FRAME AND OPTIONAL WINDOW FRAME

The Door Frame consists of a Header Tube 2" x 3" x 45 3/4" long (for 4' OC) or 57 3/4" long (for 5' OC) and a Door Jamb 2" x 3" x 81 3/4". These combine with the side post to create a 38" x 81 3/4" rough opening for your door.

Place the Door Header in between any of the side posts, except the starter rail section that has two anchor bolts in it, and fasten it to the side post with Angle Brackets on top of the Door Header. Before you install the Angle Brackets, Place a Door Jamb under the Door Header and use it to position the Header. ( see dimensions in illustration). Note that the header length is 1/4" less than the opening between side posts.

Locate the Door Jamb to the side of the frame opening that has an anchor bolt in the base rail. There must be no anchor bolt located in the rough opening that you create for your door. Fasten the door Jamb at the top to the bottom of the door header with an Angle Bracket and at the bottom to the base rail with a flat bracket on the inside of the building. One of the side Posts will form the other door jamb. The door opening must be 38" wide. Carefully measure 38" at the top and bottom of the door opening. Make sure that the Building frames and the Rough opening are plumb and square before installing screws.

You may choose to size the door frame to fit your door exactly. In this case, place the door in the opening, place the header on top of the door and attach it to the side posts with angle brackets (note that the header is 1/4" shorter than the opening between the side posts). The door jamb tube will need to be cut down to fit the space from the base rail to the bottom of the door header. Attach the door jamb at the top to the bottom of the door header with a angle bracket and to the base rail at the bottom with a flat bracket on the inside of the building. Check for plumb and square before attaching

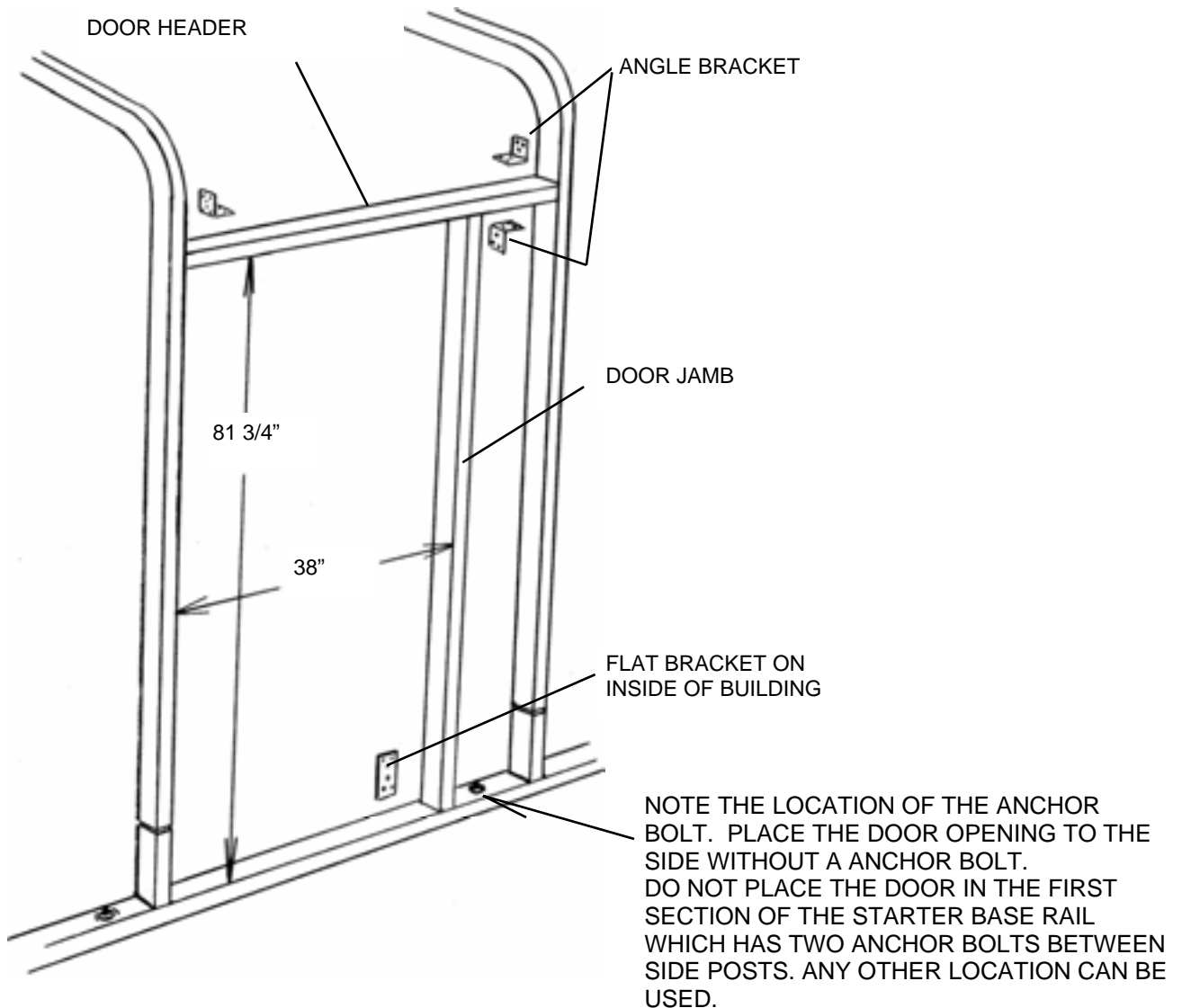

**OPTIONAL WINDOW FRAME**

If you are installing an optional window frame, Measure your window to determine the rough opening that you will need. Cut the vertical window frame tubes to the height of the rough opening. Mount the lower horizontal window frame tube to the side posts as shown at right with angle brackets. The tube should be level. Pre-mount angle brackets to the vertical frame tubes. Center and properly space them on the bottom tube to give you the correct rough opening width. Fasten them in place. Now, install the top horizontal frame tube with angle brackets. Square and plumb the vertical tubes and attach them to the top frame tube.

**The window kit includes:**

- (2) horizontal frame tubes 2" x 3" x 45 3/4" for 4' OC frames or 2" x 3" x 57 3/4" for 5' OC frames
- (2) vertical frame tubes 2" x 3" x 60" that can be cut to rough opening height
- (2) horizontal nailer tubes 1 1/2" square x 42" long with 3 holes
- (2) vertical nailer tubes 1 1/2" square x 60" long with 3 holes
- (12) #13 x 2" pan head, self-drilling screws
- (8) angle brackets with screws

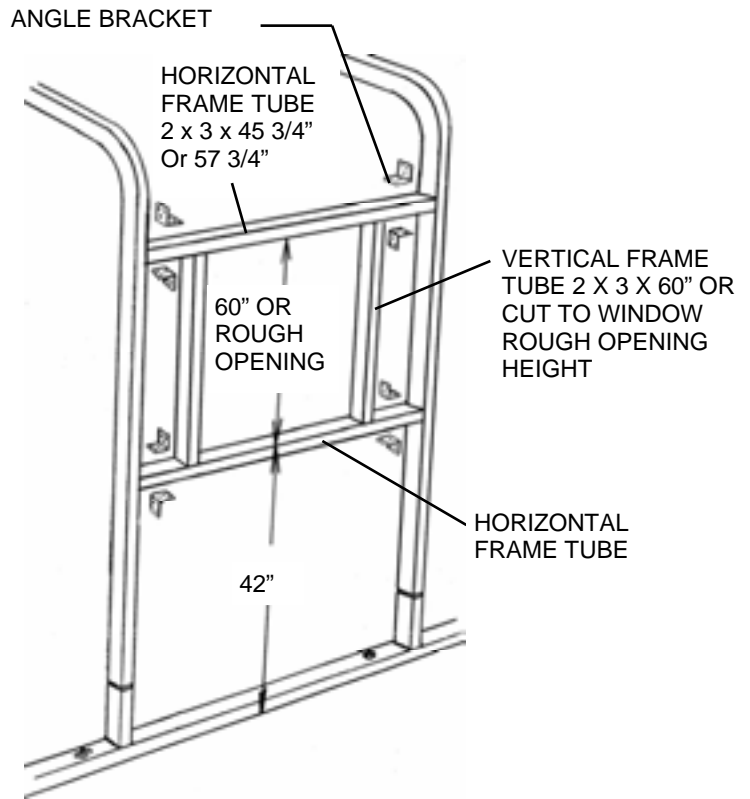

**Installing Nailer Tubes around optional window frame**

The front face of the window frames must be framed out to be flush with the flat surfaces of the hat channel. This will be accomplished by framing the window with 1 1/2" square nailer tubes. The horizontal nailer tubes for the top and bottom of the window frame are 42" long with 2 off center mounting holes at the ends. The vertical nailer tubes for the sides of the frame are 60" long with 3 mounting holes. Vertical nailer tubes must be cut to required rough opening size. Install the bottom tube first flush with the top of the bottom window frame tube and centered on the frame. Install the vertical nailer tubes flush with the insides of the window frame and the top tube cantered and flush with the bottom of the top window frame tube. See illustration. Use #13 x 2" pan head, self-drilling, square drive screws to fasten the nailer tubes to the window frame.

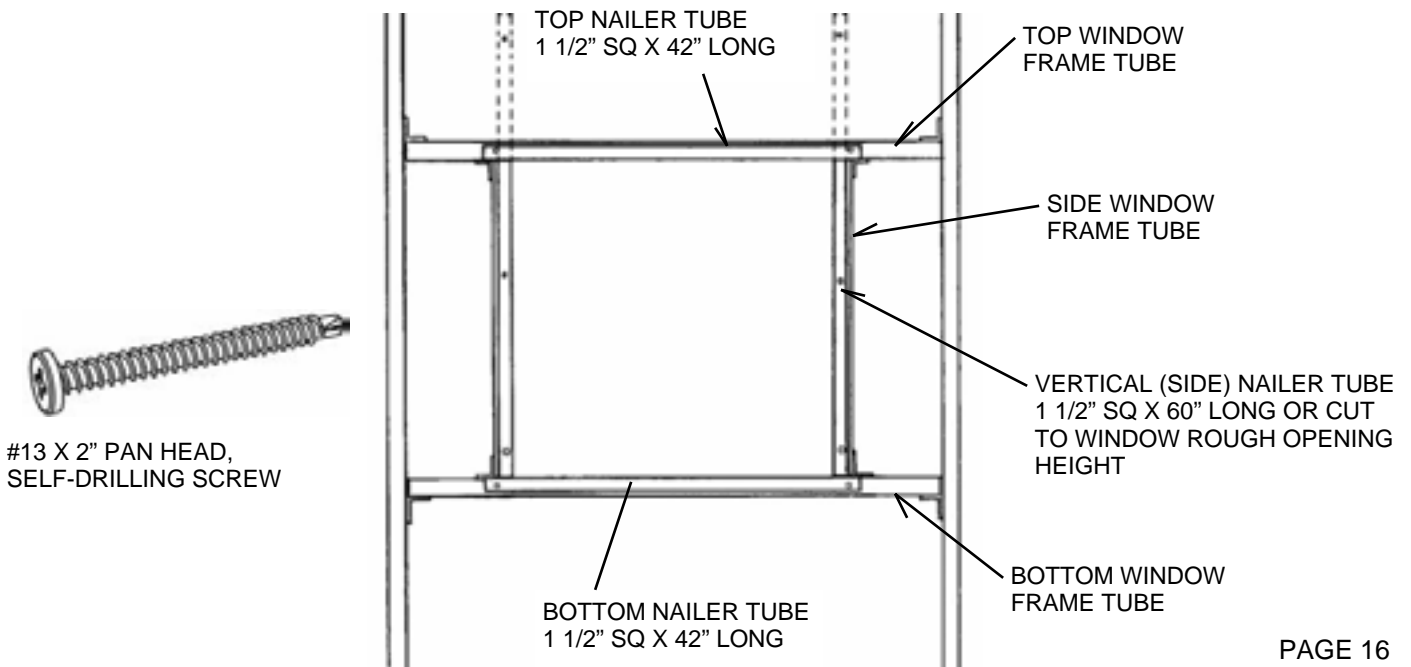



## STEP 9: INSTALLATION OF WALK DOOR ON SIDE OF BUILDING

In the Versatube frame the walk door is installed on top of the base rail. The rough opening that you installed earlier is designed for a pre-hung door. The door is typically 36" wide x 6'-8" tall.

You should have purchased a pre-hung exterior door with your building kit. The pre-hung door must be installed before you cut and install hat channel around the door frame. Follow the door manufacturer's assembly instructions for installing the door in the building rough opening. NOTE: The pre-hung door should be installed with the front edge of the frame 1 1/2" out from the building frame. This will make the front surface of the door frame flush with the hat channels on the side of the building.

All door installations require that you level and plumb the door with wood shims. Wood shims are available at any home center or hardware store. You may also have to purchase silicone caulk to properly seal the door and any windows you may be installing. Because you are installing the door in a metal frame, you will need "wood to metal self-drilling screws to fasten the door frame to the rough opening frame in the building. Depending on the type of door that you purchased, screws will be #12 x 2" or 3". If you do not use a wood to metal self-drilling screw, you will have to drill a pilot hole for the screw.

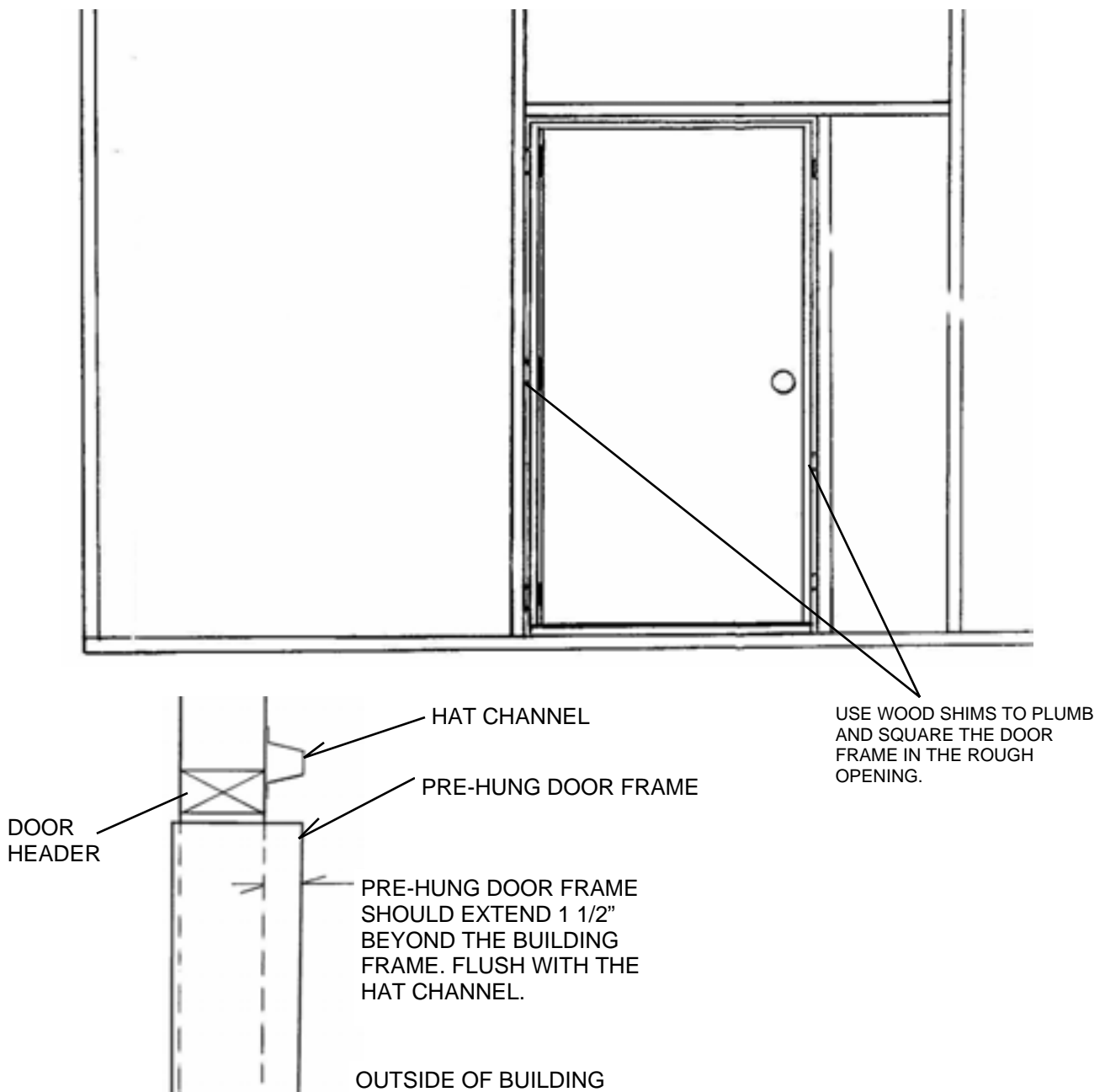

# STEP 10: INSTALLING HAT CHANNEL ON ROOF AND SIDES OF BUILDING

The purlins on the roof and the girts on the sides of your building are **Hat Channel**. Most of the hat channel that you install will be 10' long on buildings with frame sections on 5' centers or 8' long for buildings on 4' centers.

See the chart below for the location dimensions for the Hat Channel on the roof and sides of the building. You can measure and locate each hat channel as you go or mark the locations of all the channels on the front and back frame sections and snap a chalk line the length of the building to mark the hat channel locations on all of the interior frame sections.

## LOCATION OF HAT CHANNEL GIRTS ON THE SIDE OF THE BUILDING

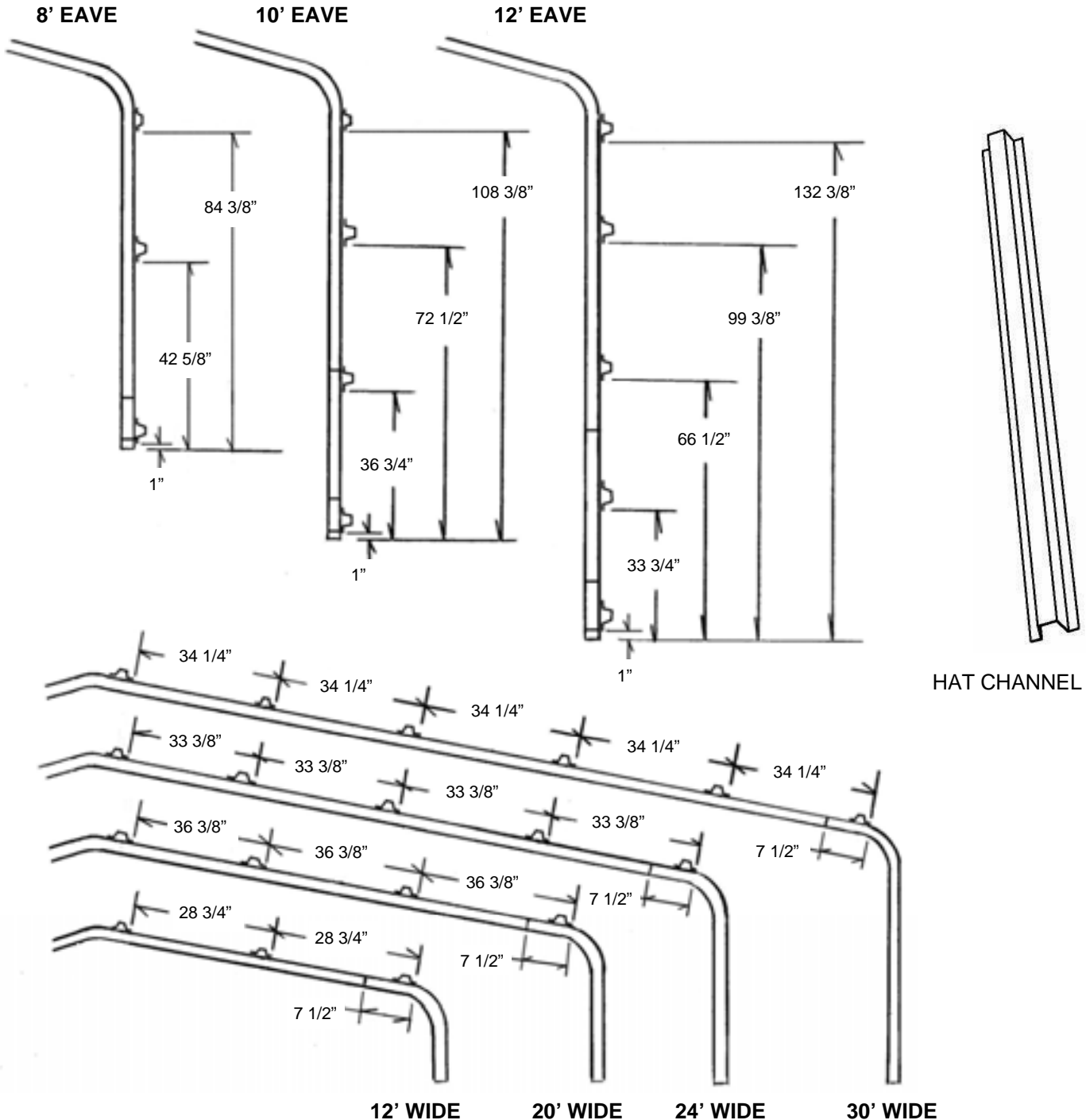

## LOCATION OF HAT CHANNEL PURLINS ON THE ROOF OF THE BUILDING

As you install hat channel the building frame will gain stiffness and strength. It is important that you check the frame sections with your level for plumb as you install each hat channel. You may want to clamp a corner diagonal brace to the frame at the front or back of the building on both sides to hold the first frame section square. Measure from the first frame section to get the remaining sections plumb.

1. Install the first hat channel along the base rail starting on one side of the building at the corner. The bottom edge of the channel should be located 1" up from the bottom of the base rail. The hat channel should start at the corner of the building, 1" from the corner or centered on the corner post. Fasten the channel to the frame with #12 self-drilling screws, one in the top flange and one in the bottom flange at each vertical post.

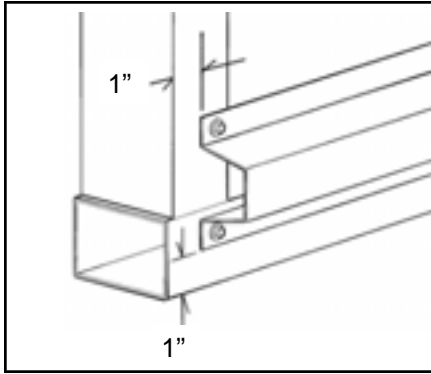

CORNER DETAIL

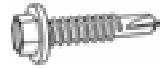

#12 SELF-DRILLING SCREW

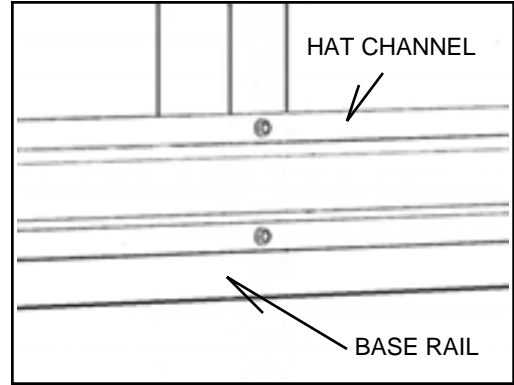

MID CHANNEL DETAIL

2. Continue Hat Channel down the length of the building using 8' lengths for 4' on center frames and 10' lengths for 5' on center frames. Butt the ends of the channels together and attach with screws as shown below. Your building may be of a length that requires you to use a 4' or 5' Hat Channel at one end of the building. If so, 4' or 5' channels are provided.

**All Versatube buildings include framing for a Walk Door to be located on one side of the building.** Follow the instructions for framing around a Walk door opening in step 4. If you installed optional window frames, see step 5 for framing around window kit.

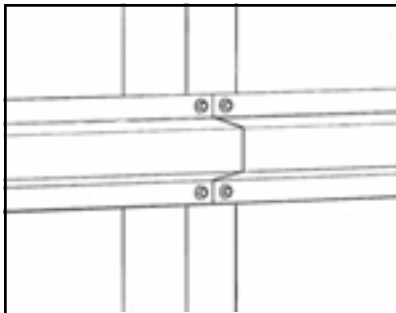

Butt the ends of Hat Channels together, centered on a vertical post and fasten each hat channel end with 2 screws as shown.

**REMEMBER TO KEEP THE VERTICAL POSTS PLUMB AS YOU ATTACH HAT CHANNELS.**

3. Continue to install the remaining runs of hat channel on the sides of your building, referring to the chart on page 15 for height location. The dimensions on the chart are from the bottom of the base rail to the bottom edge on the lower hat channel flange.

You will need to see steps 4 and 5 when you come to a door or window opening.

**4. Installation of Hat channel, Nailer Tube and Channel Brackets around door opening:**

Place a 1 1/2" x 1 1/2" x 42" Nailer Tube (with 2 off center holes) on top of the pre-hung door frame with the holes closest to the bottom edge of the tube. Center the tube on the door frame and use (2) #13 x 2" pan head, self-drilling screws to fasten the nailer tube to the building frame.

From a 8' or 10' hat channel cut (2) short pieces of channel 2" long and attach them on the side post and door jamb just below the header tube with #12 self-drilling screws. Place one screw in the top flange and one in the bottom flange. You can use a hack saw to cut the hat channel, but it will be easier if you use an abrasive disk or metal cutting blade in a circular or miter saw to make the cuts. Remember to wear your eye protection and with power saws ear protection is recommended.

Now, from the same piece of hat channel cut a piece of hat channel to go from the left side of the pre-hung door frame to the center of the next side post and one to go from the right side of the pre-hung door frame to the center of the next side post on that side of the door. Cut addition pieces of hat channel as needed from 8' or 10' lengths to match up with the number of runs that intersect the door opening on your height building. (2 runs on 8' high buildings, and 3 runs on 10' and 12' high buildings. See layout for side hat channel height locations on page 18.

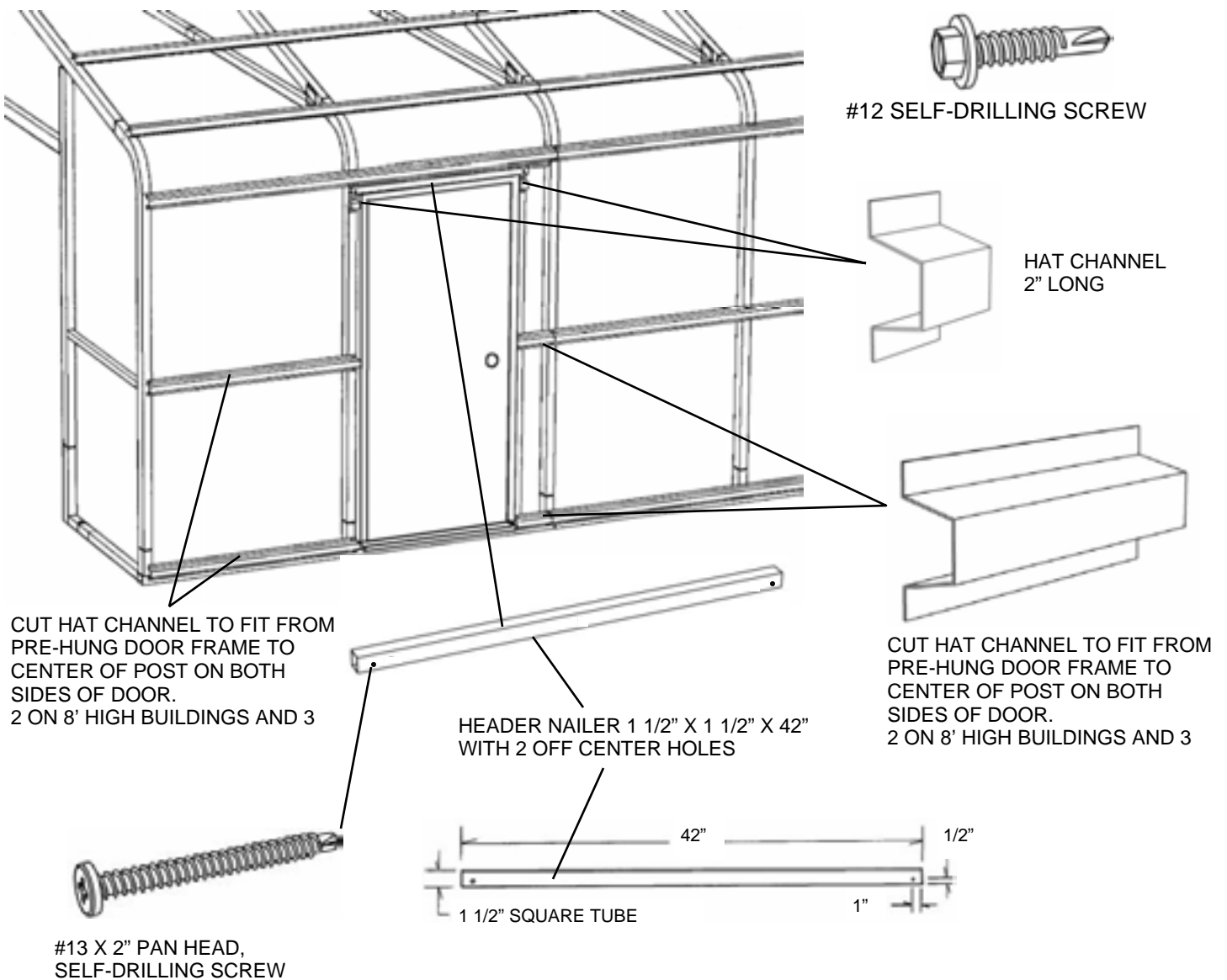

## 5. INSTALLING HAT CHANNEL AROUND WINDOW OPENINGS

When you get to a window frame with a run of hat channel, you will have to measure and cut the channel to fit around the window frame. From an 8' or 10' piece of hat channel you must cut a short piece of channel to fit from the outside of the vertical nailer to the center of the side post and a longer piece of channel to fit from the outside of the other vertical nailer to the center of the second side post. See illustration below.

Note: On taller windows, two runs of hat channel may cross the window.

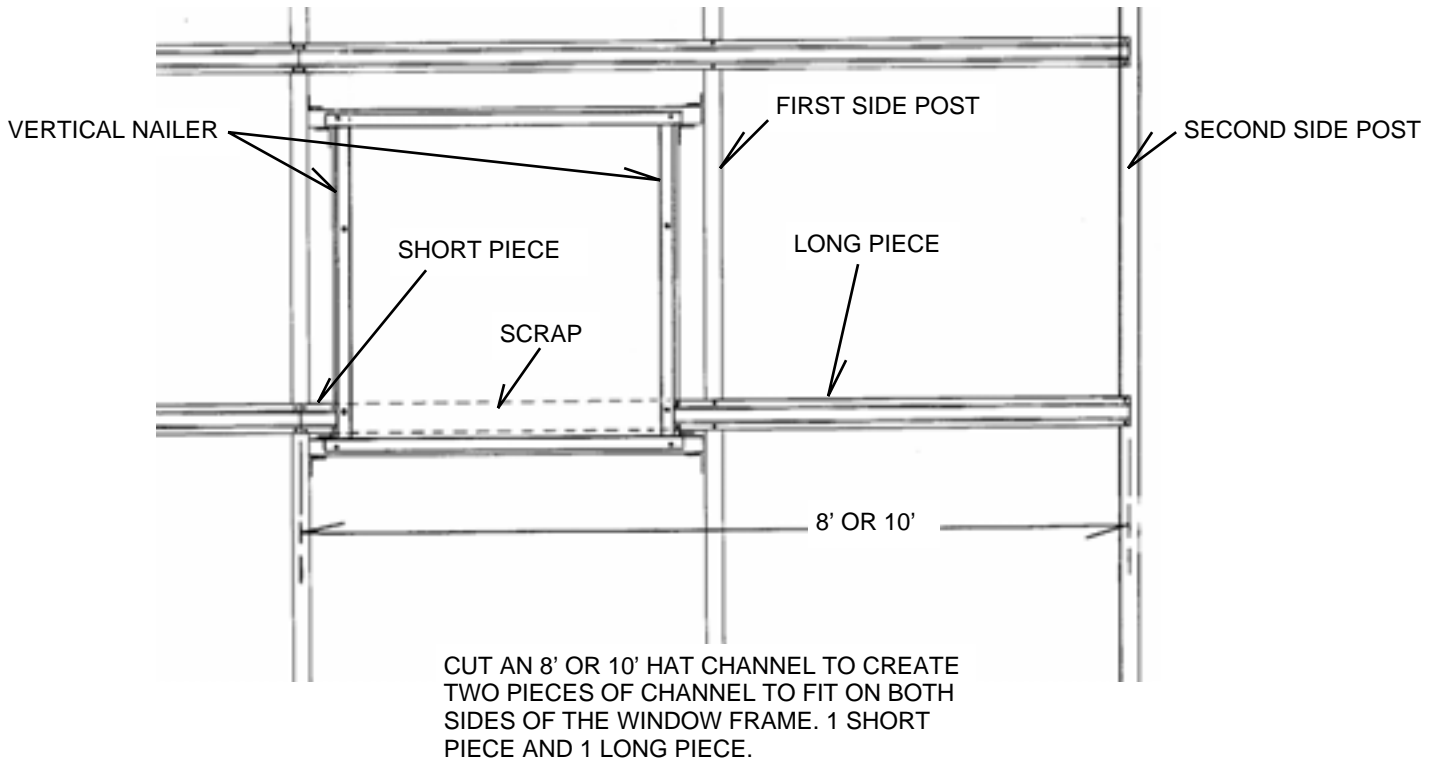

**REMINDER: CHECK THE FRAME SECTIONS FOR PLUMB AS YOU INSTALL HAT CHANNEL.**

**AS YOU MOVE ON TO INSTALL THE HAT CHANNEL ON THE ROOF CHECK THE DIAGRAMS ON PAGE 17 FOR HAT CHANNEL LOCATIONS.**

# STEP 11: INSTALLING GIRTS ON FRONT AND BACK OF BUILDING

Girts on the front and back of the building are 1 1/2" square tubes. (see illustrations of your building size for girt lengths.) Girts will be attached to the frame with two types of brackets:

**Single Brackets**, which are used to attach girts at the corners of the building or any location when the girt does not continue on the other side of a vertical post.

**Double Brackets**, which are used to attach girts that continue on both sides of a 2" wide frame member. If girts are attached on both sides of a 3" wide frame member, (this occurs on the front enclosure of the building) you will use two Single Brackets overlapped. Use #12 Self-Drilling Screws to fasten brackets to the purlins, girts, or frame. Use Pan Head Screws on the Single Bracket Tab (see detail below).

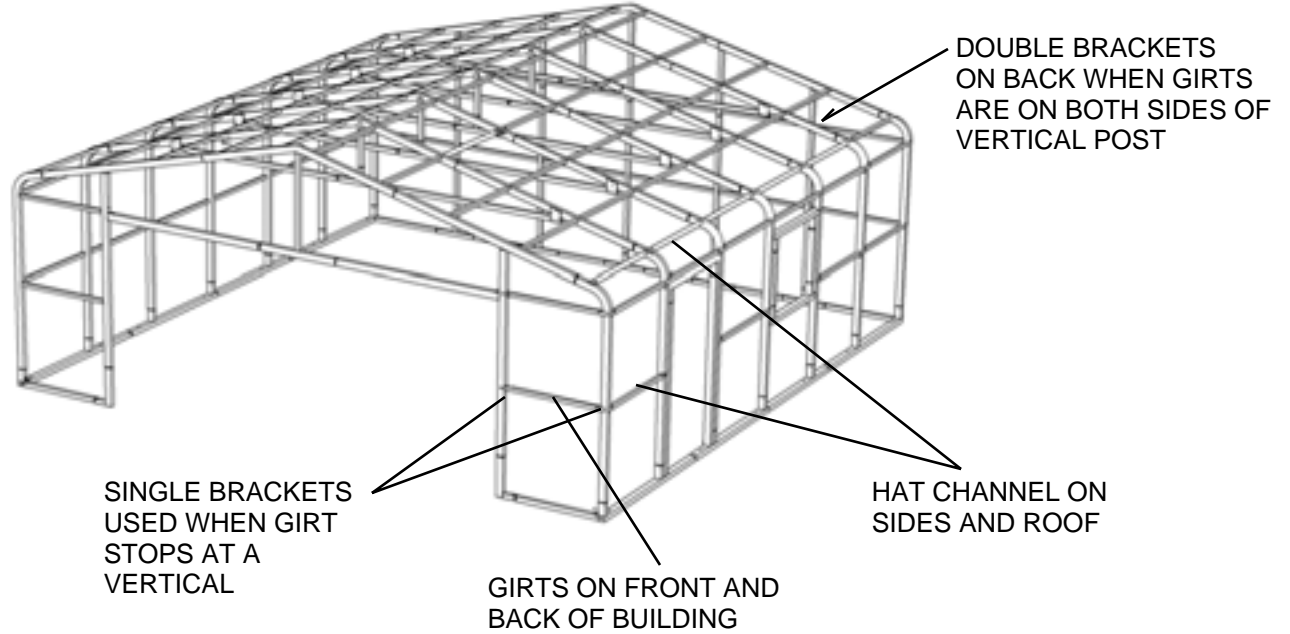
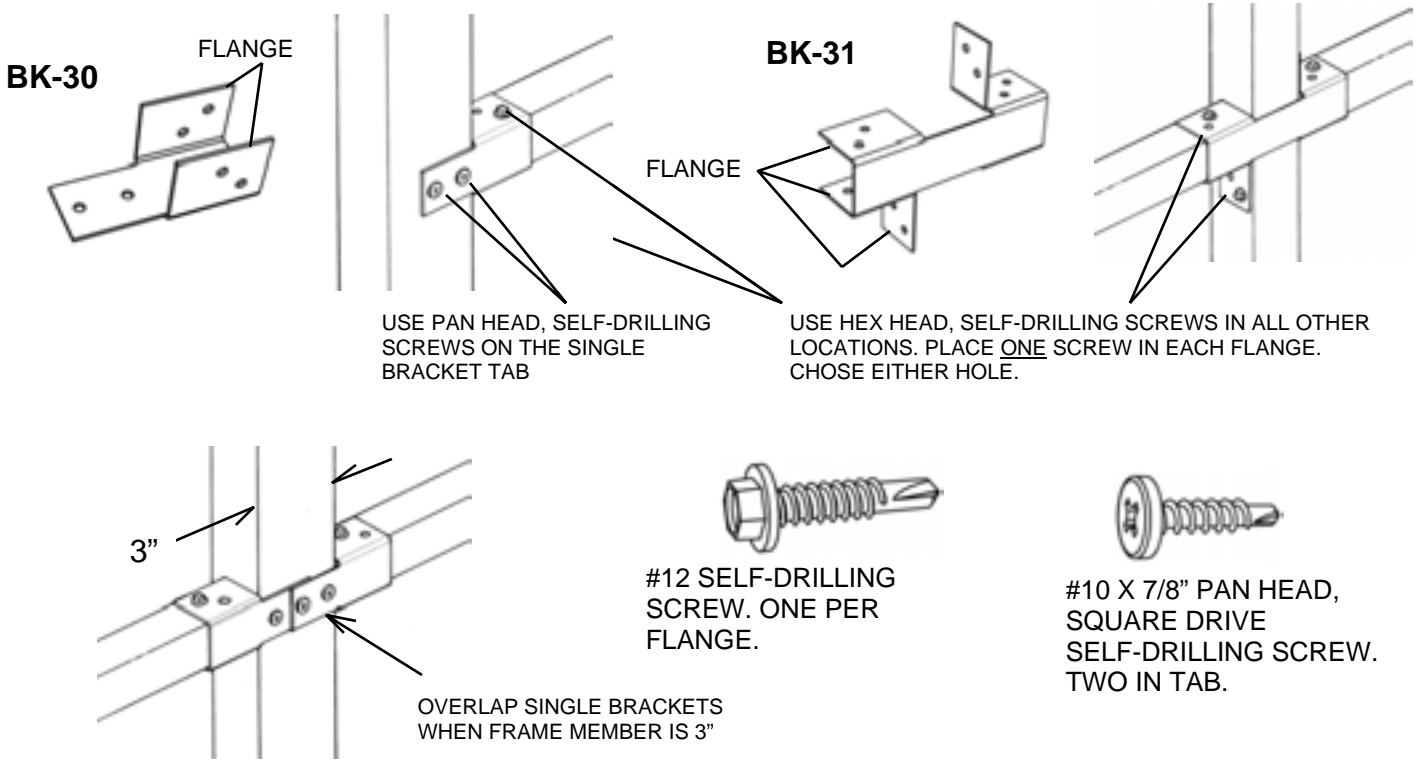

# GIRTS ON BACK OF BUILDING

ALL GIRTS ARE 1 1/2" SQUARE TUBE.

GIRT LENGTHS FOR 12', 20', 24', AND 30' WIDE BUILDINGS:

ON 12' WIDE BUILDINGS GIRTS ARE 67 3/4" LONG

ON 20' WIDE BUILDINGS GIRTS ARE 56 3/4" LONG

ON 24' WIDE BUILDINGS GIRTS ARE 68 3/4" LONG

ON 30' WIDE BUILDINGS GIRTS ARE 69" LONG

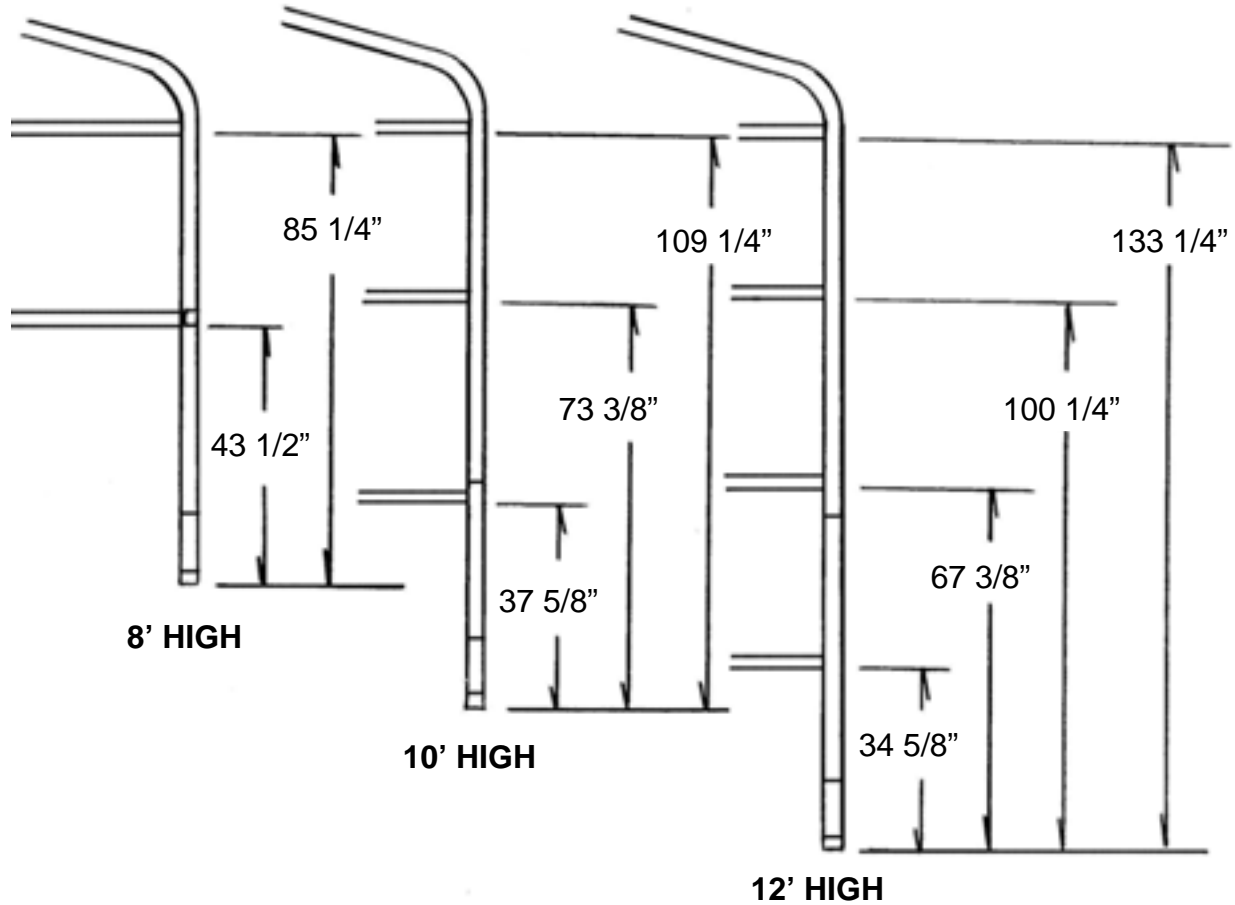

## GIRTS ON FRONT OF BUILDING

NOTE: All girts are 1 1/2" square tube.

**THE GIRTS ON THE FRONT OF THE BUILDING SHOULD BE AT THE SAME HEIGHTS AS THE GIRTS ON THE BACK OF THE BUILDING. SEE HEIGHT CHART ON PAGE 23.**

If you install a taller garage door, you will not need all of the center girts provided.

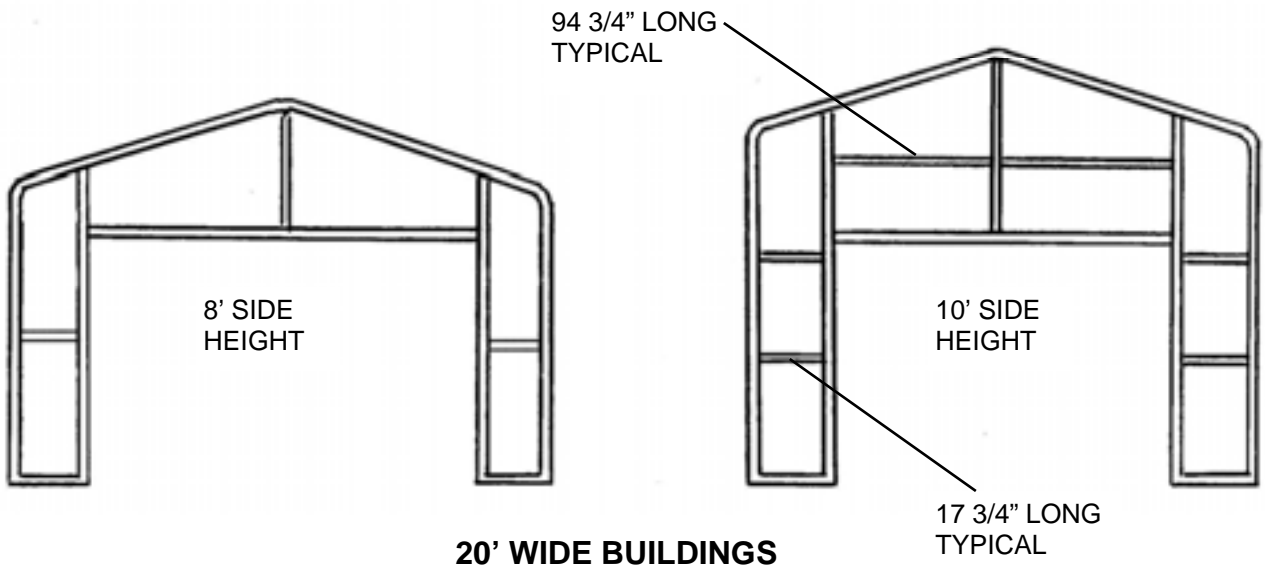
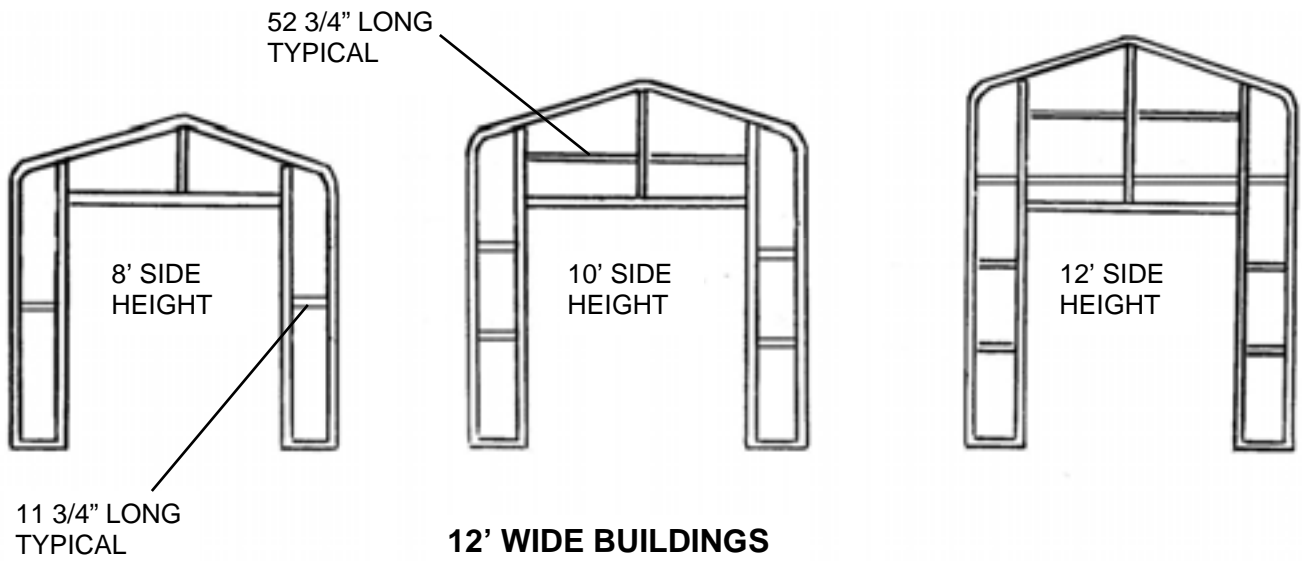



## GIRTS ON FRONT OF BUILDING CONTINUED

### 20' WIDE BUILDINGS

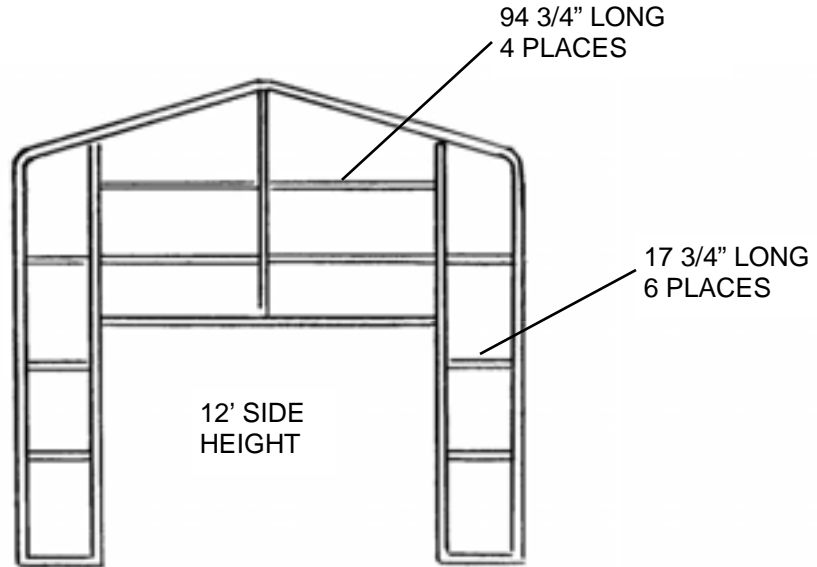

---

### 24' AND 30' WIDE BUILDINGS WITH 16' WIDE GARAGE DOOR

All measurements are to the bottom of the girts

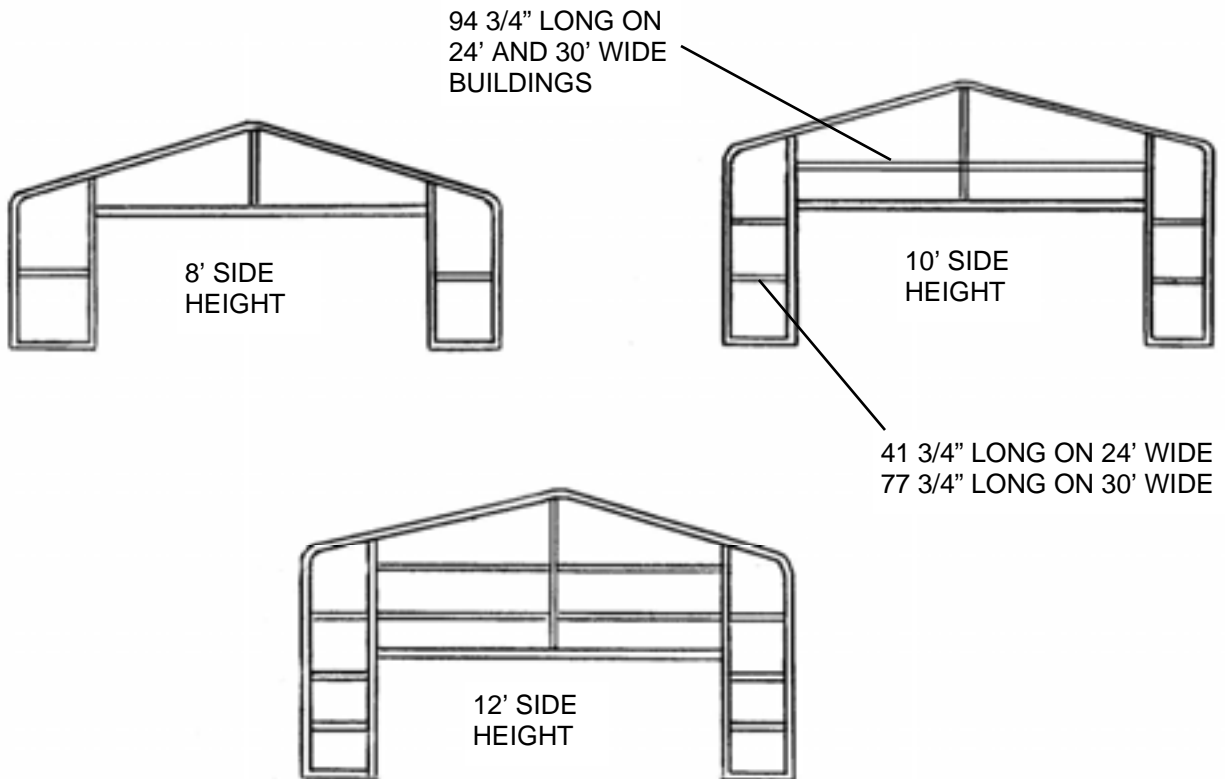

## GIRTS ON FRONT OF BUILDING CONTINUED

### 24' AND 30' WIDE BUILDINGS WITH (2) 9' WIDE GARAGE DOORS

8' SIDE  
HEIGHT

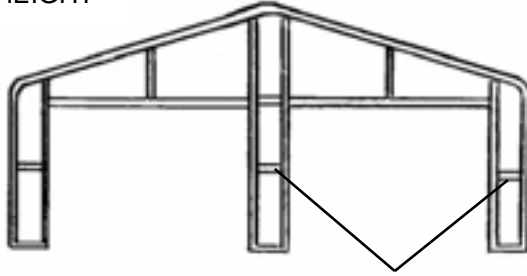

10' SIDE  
HEIGHT

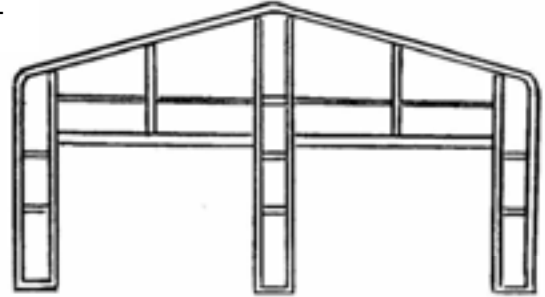

17 3/4" LONG  
ON 24' WIDE BUILDINGS  
41 3/4" LONG  
ON 30' WIDE BUILDINGS

52 3/4" LONG ON  
24' AND 30' WIDE  
BUILDINGS

12' SIDE  
HEIGHT

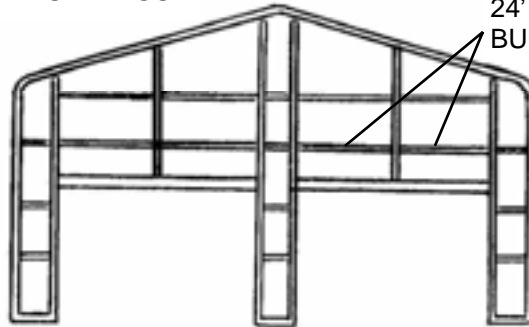

---

## STEP 11: INSTALLATION OF WALK DOOR ON SIDE OF BUILDING

In the Versatube frame the walk door is installed on top of the base rail. The rough opening that you installed earlier is designed for a pre-hung door. The door is typically 36" wide x 6'-8" tall.

Because you have the option to choose different types of doors we recommend that you follow the door manufacturer's installation instructions. You may have chosen a metal door that has a built in J-Channel and requires no additional trim or you may have chosen a door pre-hung in a wood frame. This type of door will require the installation of additional J-Trim. The J-Trim is provided in your building kit and the installation of the J-Trim is on the next page.

All door installations require that you level and plumb the door with wood shims. Wood shims are available at any home center or hardware store. You may also have to purchase silicone caulk to properly seal the door and any windows you may be installing. Because you are installing the door in a metal frame, you will need "wood to metal self-drilling screws to fasten the door frame to the rough opening frame in the building. Depending on the type of door that you purchased, screws will be #12 x 2" or 3". If you do not use a wood to metal self-drilling screw, you will have to drill a pilot hole for the screw.

## STEP 12: INSTALLATION OF OPTIONAL WINDOWS

Install optional windows at this time following the window manufacturer's installation instructions. Most windows are installed through a nailing flange around the window. If the window has a built in J-Trim you may not have to install the J-Trim provided in your kit. You can use the painted self-drilling screws provided or the plated pan head screws you used on the tongue of the single purlin brackets you installed on the front and back of the building.

You will need silicone caulk to seal windows. If your window has no built in J-Trim see that installation on page 27.

# STEP 13: INSTALLATION OF SIDE WALK DOOR TRIM

If door J-Trim is not built in to your door install it at this time.

Cut two pieces of Side J-Trim to fit from the bottom of the sheeting ledge on the slab to the top of the door frame. Cut one piece of Top J-Trim 2" longer than the door frame. (Note that this piece of J-Trim will extend out beyond the door frame to the ends of the Side J-Trim front flange on both sides of the door. You may want to place the Side J-Trim on both sides of the door frame and take a measurement to check that distance before you cut the Top J-Trim.)

Attach the Side J-Trim on both sides of the door to the hat channel with Pan Head Self-Drilling Screws.

Clip two 1" long slits in the ends of the Top J-Trim as shown below. (Both ends of the Top J-Trim) Now, Place the Top J-Trim on top of the Side J-Trim over the door and fold the tabs that you created at the ends of the Top J-Trim down into the top of the Side J-Trim. Attach the Top J-Trim at both ends to the top nailer with Pan Head Screws.

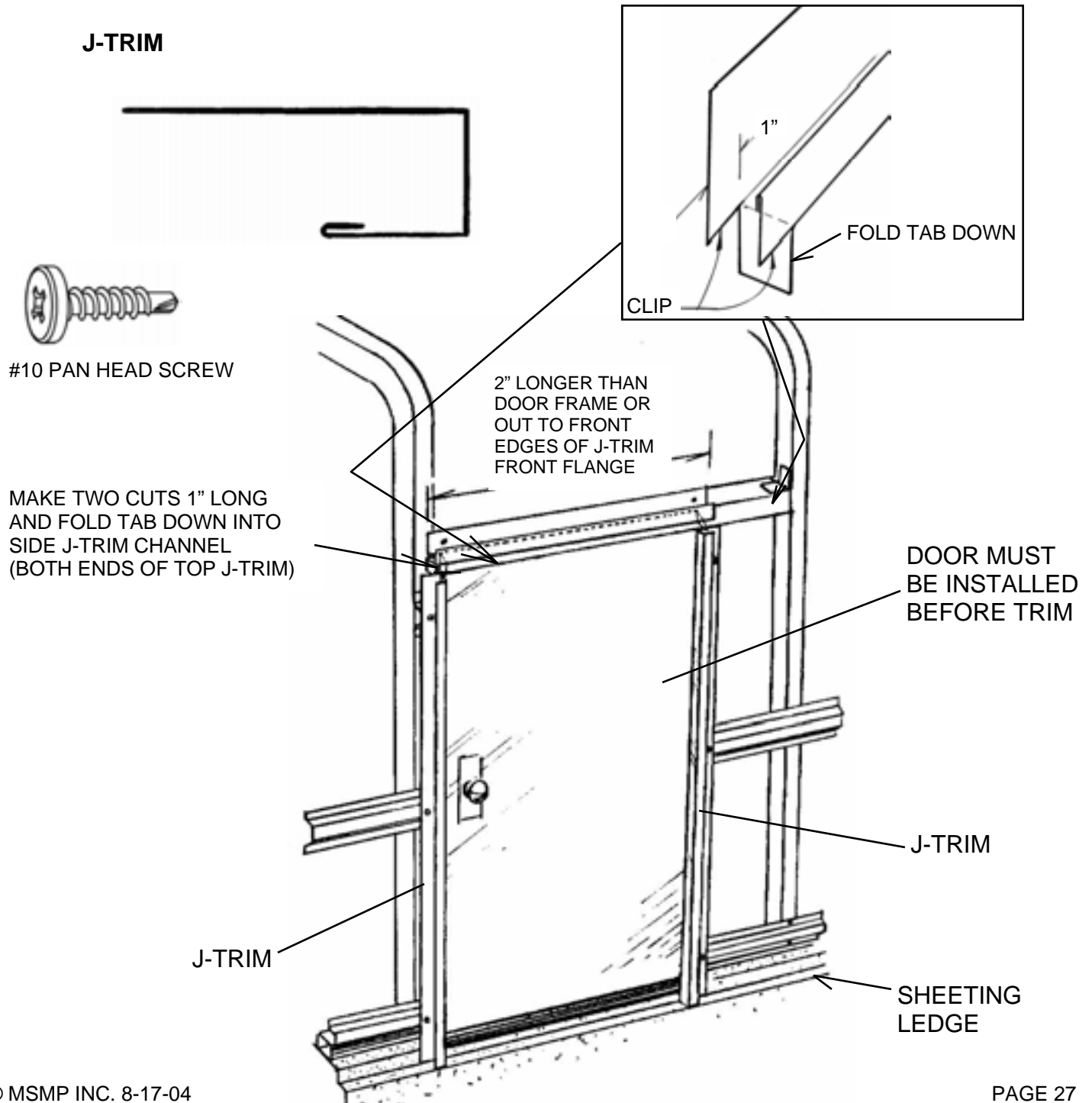

# STEP 14: INSTALLING TRIM ON OPTIONAL WINDOW

**IF YOU DID NOT PURCHASE A WINDOW, SKIP TO THE NEXT PAGE**

Cut a piece of Bottom J-Trim 2" longer than the window width. Center it along the bottom of the window and fasten it at both ends with Pan Head Self-Drilling Screws. Be careful not to hit the heads of the screws used to mount the window.

Cut two pieces of Side J-Trim to fit from the top of the bottom J-Trim that you just installed to the top of the window. Fasten both pieces of side J-Trim at both ends with Pan Head Screws.

Cut one piece of J-Trim to fit from the outside edge of the front flange on one side J-Trim to the other. The distance will be about 2" longer than the window frame. Now, clip two 1" long slits in both ends of the Top J-Trim as shown below. Place the Top J-Trim on top of the Side J-Trim and fold the end tabs that you created down into the Side J-Trim channels. Fasten the Top J-Trim at both ends with Pan Head Screws.

## J-TRIM



#10 PAN HEAD SCREW

NOTE: WINDOW MUST BE INSTALLED BEFORE WINDOW TRIM

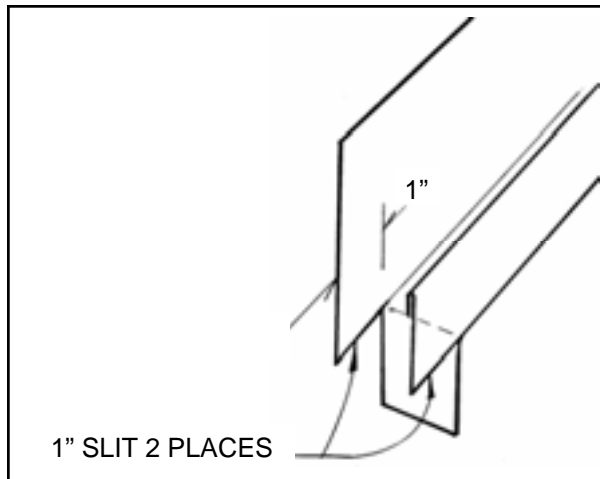

1" SLIT 2 PLACES

MAKE TWO CUTS 1" LONG AND FOLD TAB DOWN INTO SIDE J-TRIM CHANNEL (BOTH ENDS OF TOP J-TRIM)

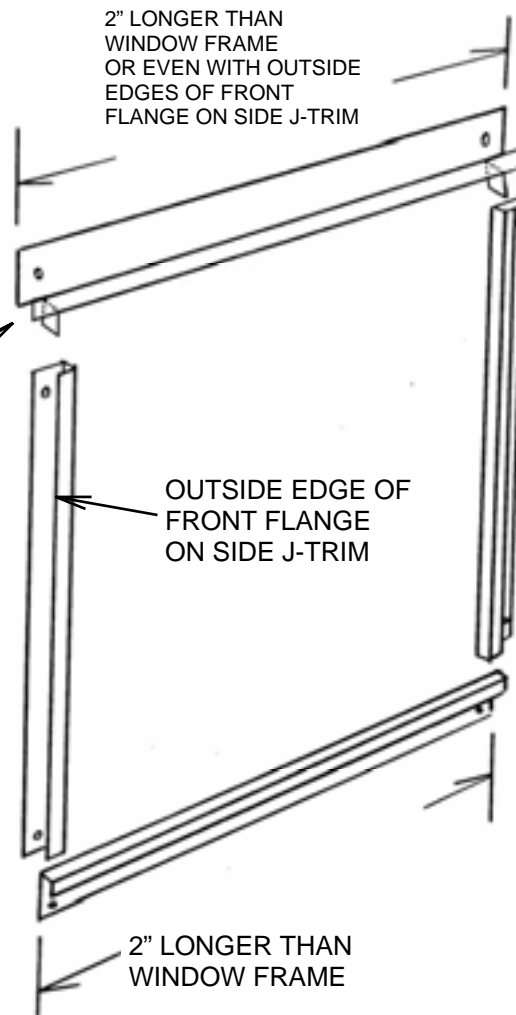

# STEP 15: INSTALLING TRIM ON THE GARAGE DOOR FRAME

## ANGLE TRIM INSTALLATION:

Cut two pieces of Angle Trim to fit from the concrete slab to the top of the door jamb (bottom of the door header) for each door. This will trim out the door jambs.

If you have a 9' wide garage door Cut one piece of Angle Trim to fit the inside width of the garage door opening. (It should be 9' long). This will trim out the door header.

If you have two 9' wide doors cut two pieces the width of the door opening.

If you have one 16' wide garage door you will be using (1) 10' piece of Angle Trim and you will need to cut a 6'-3" piece of Angle Trim. The 6'-3" trim will overlap the 10' piece 3" to trim out the under side of the door header.

Fasten the Angle Trim with Painted #12 x 1" Self-Drilling Screws with Rubber Washers every 2'.

ORDER OF INSTALLATION: (1) ANGLE TRIM, (2) J-TRIM, (3) SIDE J-TRIM, (4) TOP J-TRIM

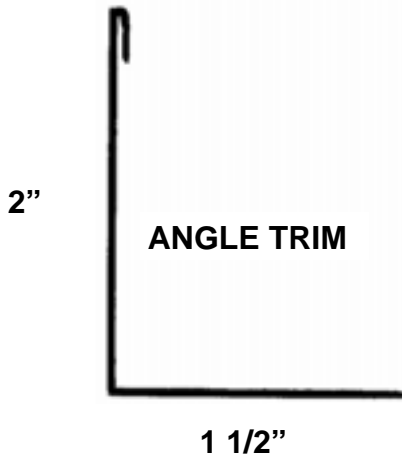

#12 X 1" PAINTED, SELF-DRILLING SCREW WITH RUBBER WASHER

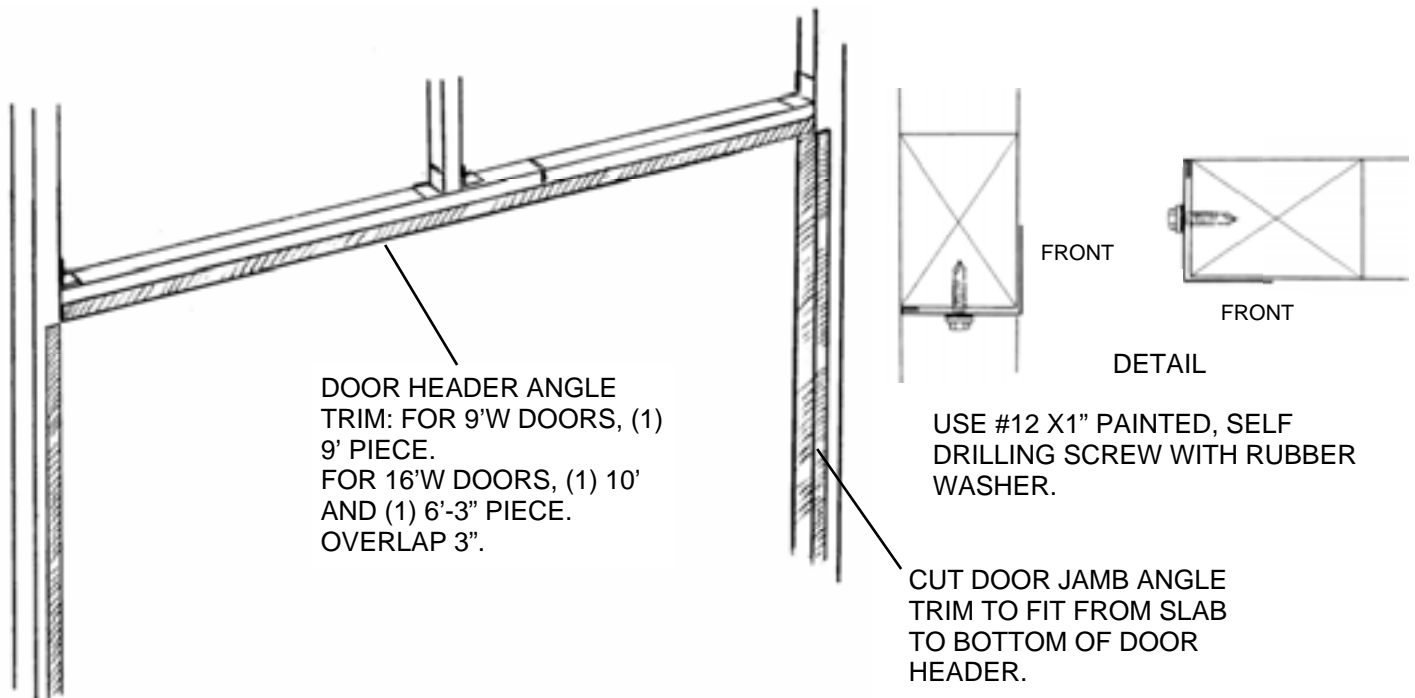

## INSTALLATION OF J-TRIM AROUND GARAGE OVERHEAD DOOR:

Cut two pieces of J-Trim to fit from the bottom of the sheeting ledge to the top of the door jamb (bottom of the door header). This will be the side J-Trim.

Top J-Trim: If you have a 9' wide door cut a piece of J-Trim 110" long and cut two 1" slits in both ends as shown in detail. The slits will create tabs that will fold down into the door jamb Side J-Trim. See illustration.

If you have a 16' wide door you will need to cut a 6'-5" long piece of J-Trim that will overlap a 10' piece of J-Trim 3".

Attach the Side J-Trim first at both ends and two additional places equally spaced from top to bottom with Pan Head Self-Drilling Screws. See illustration below for location of Side J-Trim.

Place the Top J-Trim on top of the Side J-Trim along the door header. Fold the end tabs, that you created with the 1" slits, down into the J-Trim channel and attach the at both ends and two on three places down the length with Pan Head, Self-Drilling Screws. (Be sure to place one screw in the overlap joint if you have one.)

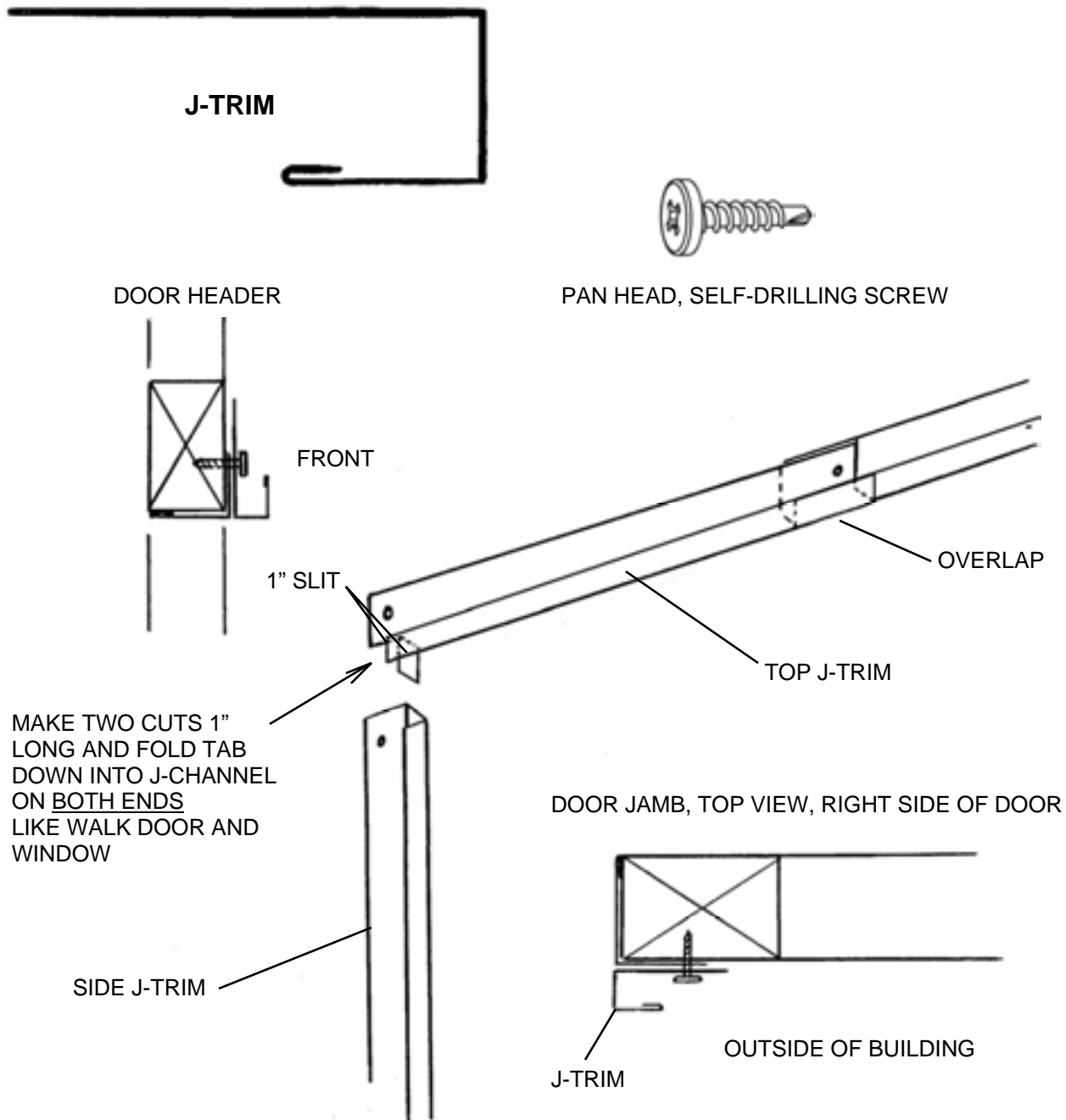

## STEP 16: INSTALLING SIDE SHEET METAL PANELS:

**IMPORTANT:** If you will be installing 1/4" foil insulation on your building, go to pages 42 and 43 and read the instructions for installing insulation. Insulation must be installed between the frame and the sheet metal panels.

### SHEET METAL PANELS FOR THE SIDE OF THE BUILDING ARE 8'-1", 10'-1", OR 12'-1" LONG.

Start at one corner of the building. (It is preferred that you chose a corner that is away from the prevailing wind). Make sure that the frame is plumb when installing the first side panel. All additional panels will depend on the first panel being plumb and square.

Carefully place the first panel on the slab sheeting ledge (or at the bottom of the base rail if no sheeting ledge is available.) Place the overlap edge at the starting corner of the building. This will allow you to easily overlap the second panel over the first and so on down the length of the building.

Attach the panels to the hat channels with #12 x 1" painted, Self-Drilling Screws with rubber washers. Place one screw about 3/4" to one side of each major rib.

NOTE: It is important to keep the panels from stretching or compressing in width as you install them. The panels should be 36" from the center of the major rib on one side of the panel to the center of the major rib at the other side of the panel. Measure each panel as you go or pre-mark the building frame every 36" to check the panel width as you go. The last panel installed on the side on the building should come out flush with the other end of the building frame if the length is devisable by 3. If not (example 20' or 25' long building) you will need to trim the last panel to be flush with the building frame.

Remember to be careful not to scratch up the bottom of the panels as you place and adjust them on the concrete slab or sheeting ledge.

Tip: To keep the screws in a straight line down the length of the building, install screws next to the 1st major rib. Hold a straight edge between the center point of the screw and the center of the hat channel at the other side of the panel and mark dots along that line where the remaining screws will be located with a felt tip marker. You can also tie a small loop in one end of a string, hook it over the first screw and draw the string to the center of the hat channel. Holding the string taut, use a felt marker to mark location points for the remaining screws. A speed square and a pencil can also be used.

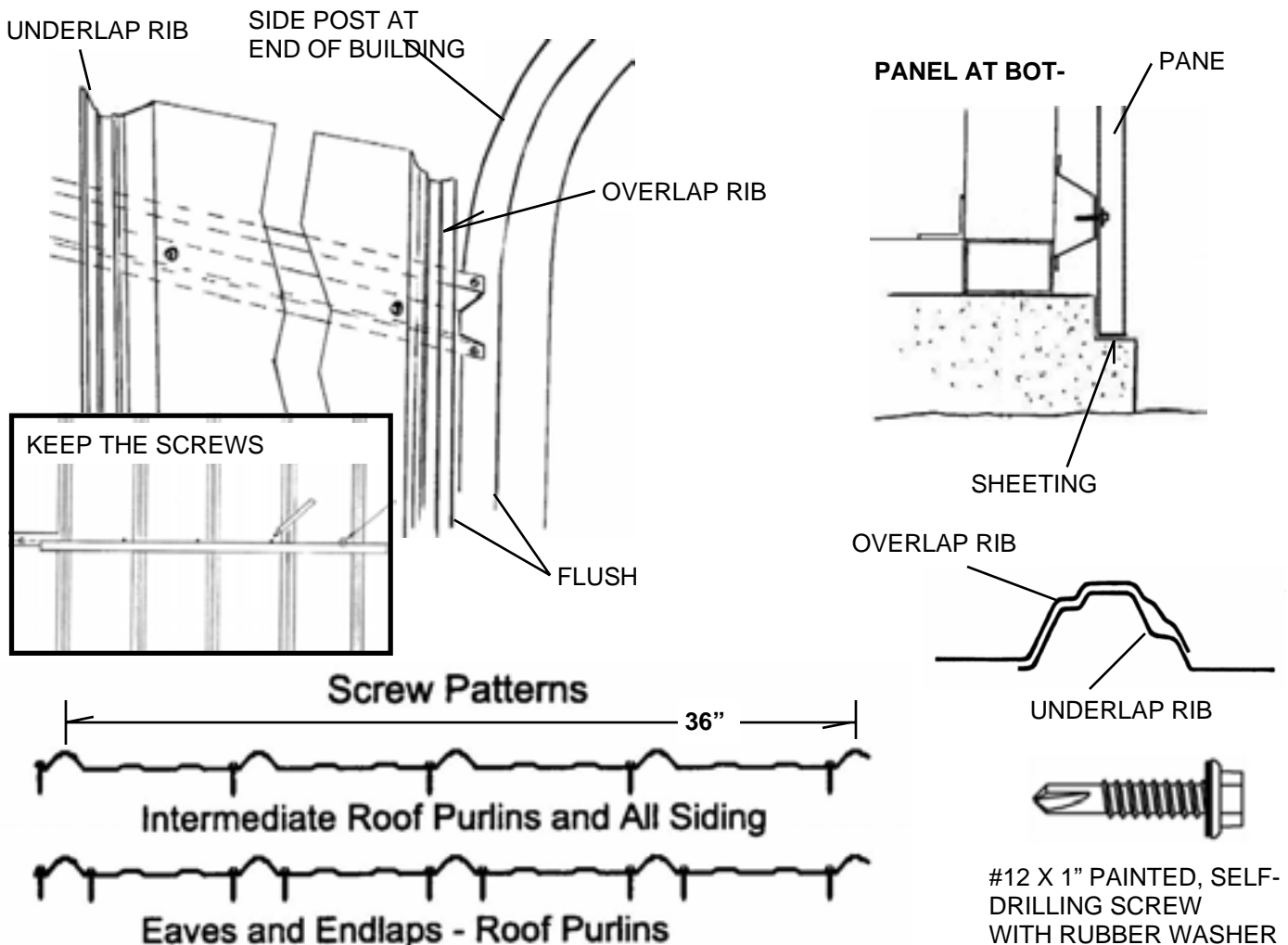

# STEP 17: INSTALLING GABLE END SHEET METAL PANELS

## INSTALLING BACK PANELS:

If you building is 12', 24', or 30' wide start in the middle of the building and work to the sides. See the panel layout drawing on the following pages for your size building. The drawing will give you the panel lengths and locations. If your building is 20' wide, center the first panel in the building width and work to both sides.

Start by placing the under lap edge of the first panel flush with one edge of the back center frame post on the 12' and 24' wide buildings. On the 30' wide building you will need to measure and mark the center of the building on the girts and base rail. Make a mark 1" to the side of the center marks. This will be the edge of the first underlay rib of the first panel. On 20' wide buildings, locate the center major rib of the first panel in the center of the building.

The length or height of the sheet metal panels are sized to fit your building. (See drawing on following pages of your building size for panel lengths). To cut the roof angle on the top of the panel measure down on the outside edge of the panel 9 1/2" and make a mark. Now, draw a line between the upper corner and the mark. This will be the angle cut for the roof pitch. On the 20' wide building, first panel, measure down on both sides of the panel 4 3/4" and draw a line back up to the center of the panel and cut along the lines. On all additional panels use the 9 1/2" measurement down one side as described above. Cut with large straight cut tin snips. Fasten the first panel to the back girts with 1" painted self-drilling screws with rubber washers. Do Not place any screws next to the overlap rib until you lift and insert the underlay edge of the next panel in that direction.

On 12', 24', and 30' wide buildings the second back panel will also start in the center of the building with the overlap rib in the center of the building. Measure and cut the top of this panel opposite of the first panel. (The overlap rib will be the top corner measurement and the underlay rib will be the low measurement.) Note that panels going to one side of the building will lap under the previous panel. You will need to leave out the screws in the overlap rib until the next panel is installed. On 20' wide buildings, the second panel can go to either side of the first panel.

Measure and trim the top angle on the remaining panels as you did the other panels. (9 1/2" down one side and up to the opposite corner) When you get to the sides of the building trim the last panel to be flush with the building frame. (NOTE: The edge can extend out about 1 3/4" and still fit under the corner trim.)

## INSTALLING FRONT PANELS:

Measure, mark, and cut the top angle on the front panels as you did the back panels. You can either measure and cut the door openings or put the panels up against the building, mark the door openings, take the panels down and cut the door openings. If you place the panels against the building to mark the door opening add about 1/4" to the opening marks to make sure that the J-Trim will not interfere.

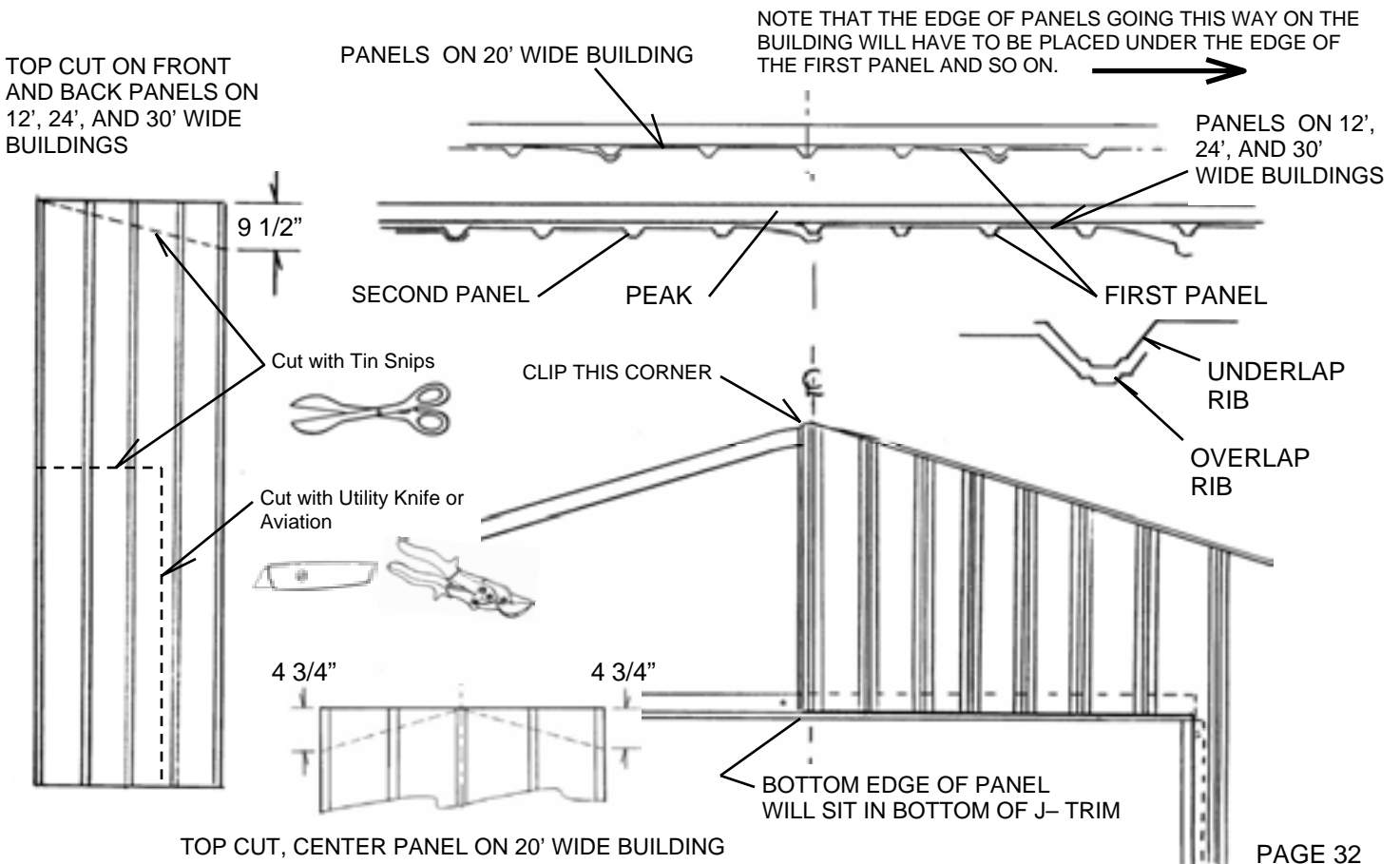



# PANEL LAYOUT AND PANEL LENGTH FOR FRONT AND BACK OF BUILDING

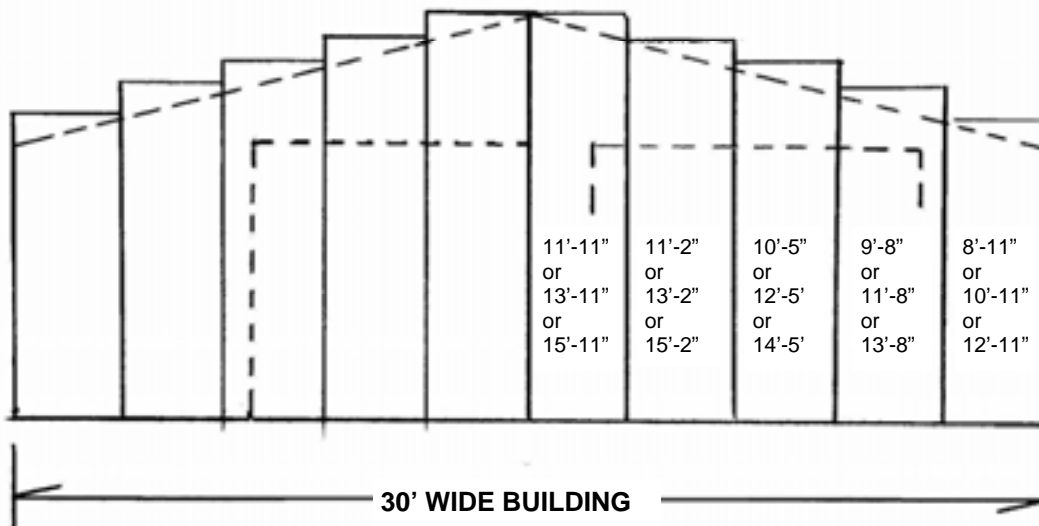
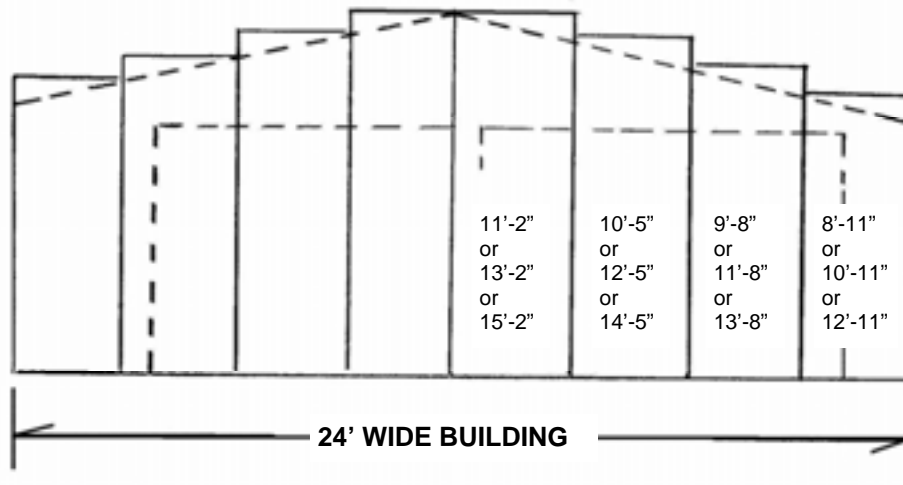
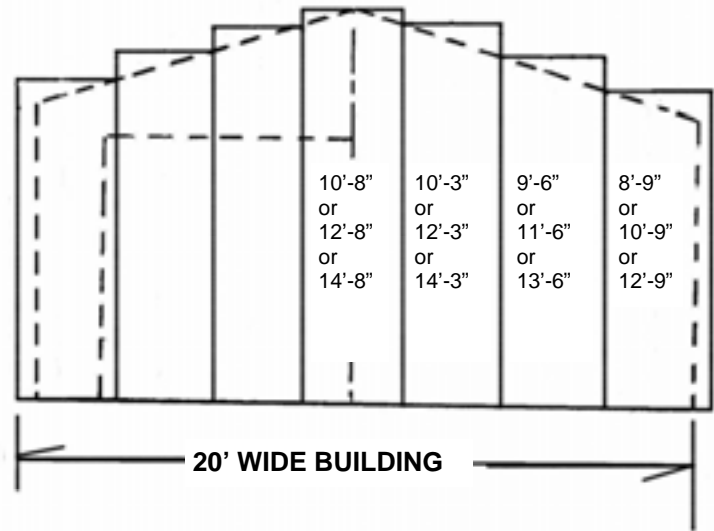
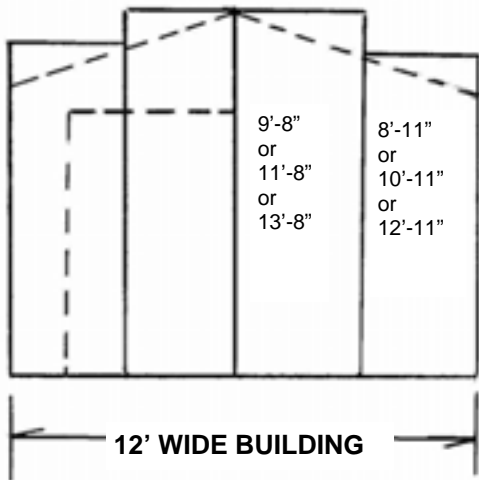

## STEP 18: INSTALLING CORNER TRIM

Cut corner trim to fit the corner height of your building. Corner trim should sit down in sheeting ledge if your slab has one. Install a piece of Corner Trim on the 4 corners of the building with 1" Painted, Self-Drilling Screws. Install the screws through the flat flanges at the edges of the trim into the wall girts (front or back) hat Channel (sides).

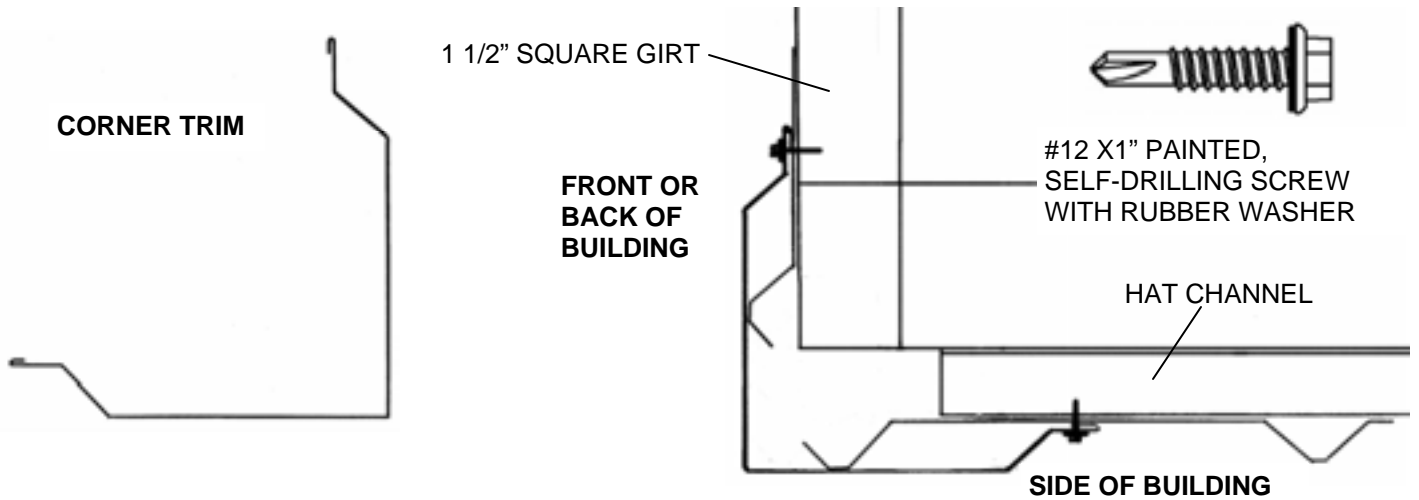

## STEP 19: INSTALLING EAVE TRIM

Install Outside Foam Closure Strips along the outside, top edge, of every side panel before you install Eave Trim. Trim the Closures as needed at the corners of the building. ( See illustration at lower right.)

Attach the Eave Trim at the top of the side sheet metal all the way down both sides of the building with #12 x1" Painted, Self-Drilling Screws with Rubber washers. Place the screws into the center of every other major rib.

To position the Eave Trim place a straight board or level on top of the roof frame and extend it out to act as a stop for the top of the Eave Trim. See the illustration below. Eave Trim comes in 10' lengths. You will need to overlap the trim about 3" at the ends. Trim excess at end of building flush with the outside of the corner trim.

Eave Trim should overlap Corner Trim. Your trim will look better if you start at the back of the building and work forward.

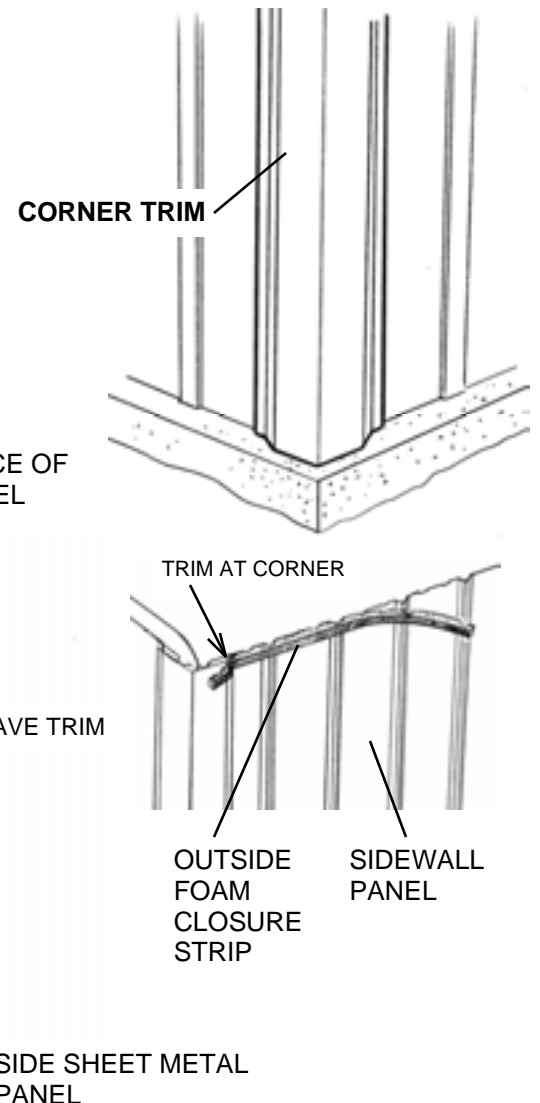

## STEP 19: INSTALLING ROOF SHEET METAL PANELS

**LENGTH OF ROOF PANELS: 12' WIDE BUILDING 6'5" LONG, 20' WIDE BUILDING 10'-7" LONG, 24' WIDE BUILDING 12'-7" LONG, 30' WIDE BUILDING 15'-9" LONG.**

### YOU WILL NEED AT LEAST TWO PEOPLE TO INSTALL ROOF SHEET METAL PANELS

One person will be on a tall step ladder, extension ladder, or scaffold inside the building at the building peak and the other on the outside of the building at the eave. An additional person on the inside of the building on a step ladder close to the side wall can be helpful in lifting the panels onto the roof.

The roof metal is sized to allow a 2" overhang at the eave. We recommend that you measure up the gable end wall frame from the outside edge of the eave trim and put a mark on the outside of the peak portion of the frame. The distance should be the length of your roof sheet metal minus 2" (example: on a 20' wide building the roof panels are 127" long. The measurement that you would use is 125".) See illustration on next page.

Now, about 1/2" down from the top surface of the peak drive a #12 self-drilling screw into the front of the frame about half way in at your mark. This screw will be an anchor for a mason line (or string) to be stretched from the front of the building to the back. This string will be used to locate the top of the roof sheet metal and keep it straight down the length of the building.

Measure and drive another screw into the outside of the frame at the back of the building. Tie and stretch a mason line or nylon string between the two screws.

Place the first sheet of roof sheet metal at the front or back edge of the roof flush with the outside of the building frame. You should start on the same end of the building that you started the side metal. Place the Overlap edge of the panel flush with the end of the building frame.

The person at the upper end of the panel must line the panel edge up with the edge of the building and set the upper edge of the panel even with the string. The person at the lower end of the panel should line the edge of the panel with the edge of the building frame and attach the edge of the panel to the lower roof purlin with a 1" painted, self-drilling screw with rubber washer.

The person at the top should then attach the edge of the panel flush with the end of the building. The person at the bottom should then measure the distance from the center of the first rib to the center of the last rib. Set the distance at 36" and attach that edge of the panel to the lower purlin. Then take a measurement from the under lap edge of the panel to the next Roof/Wall Frame Section and the person at the top must set the top edge at the same distance and attach the top edge of the panel to the top roof purlin. This will assure you that the panels at the top and bottom will come out even with the other end of the building. Now, install remaining screws into top and bottom roof purlins. Use the same straight edge or string method that you used on the sides of the building to keep the screws straight and make sure that you hit the purlins with the screws. At the eave or lower end of the roof panel place one screw on both sides of each major rib.

We recommend that you install one screw next to the under lap rib of the panel at each roof purlin at this time. This will make the roof more secure when you have to walk on it, and give you location points for installing the remaining screws later when the purlins are not visible. (A third person will save time and energy with this step.)

Place the overlap edge of the next roof panel over the under lap edge of the previous panel. Line the panel up with the string at the top and attach that edge at the top and bottom of the panel. Now, take the same measurements that you did on the first panel. 36" between the center of the first and last rib. Attach at the bottom, measure to the next frame section, set the top edge at the same dimension and attach the top of the panel. Place one screw in remaining roof purlins at the edge of the panel.

Repeat this installation method down the length of the building.

When you install the panels on the other side of the roof, you will have to work the top side of the panels from one side or from the roof on the other side.

When all roof panels have been installed you must get up onto the roof and use the straight edge or string method to install the remaining screws. **When walking on the roof step on the flats only (not on major ribs) . Step on or very near the purlins or frame members. The screws should be a guide to purlin and frame locations.**

**(See illustrations on next page)**

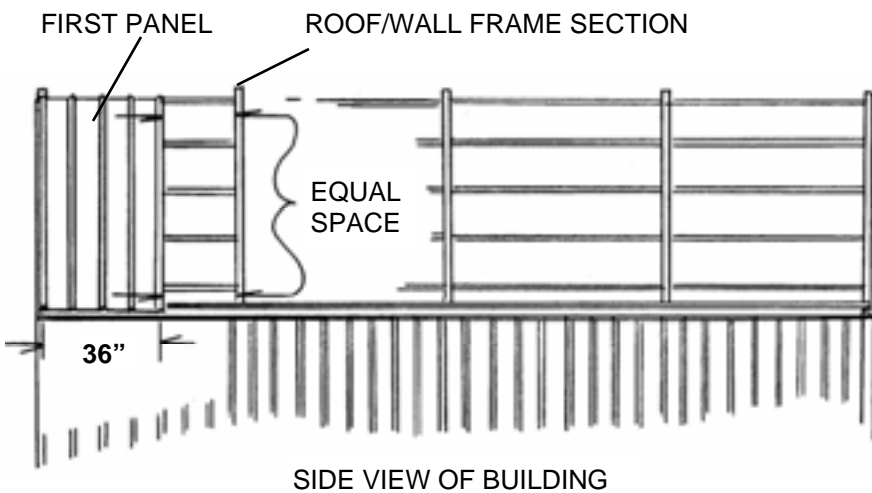
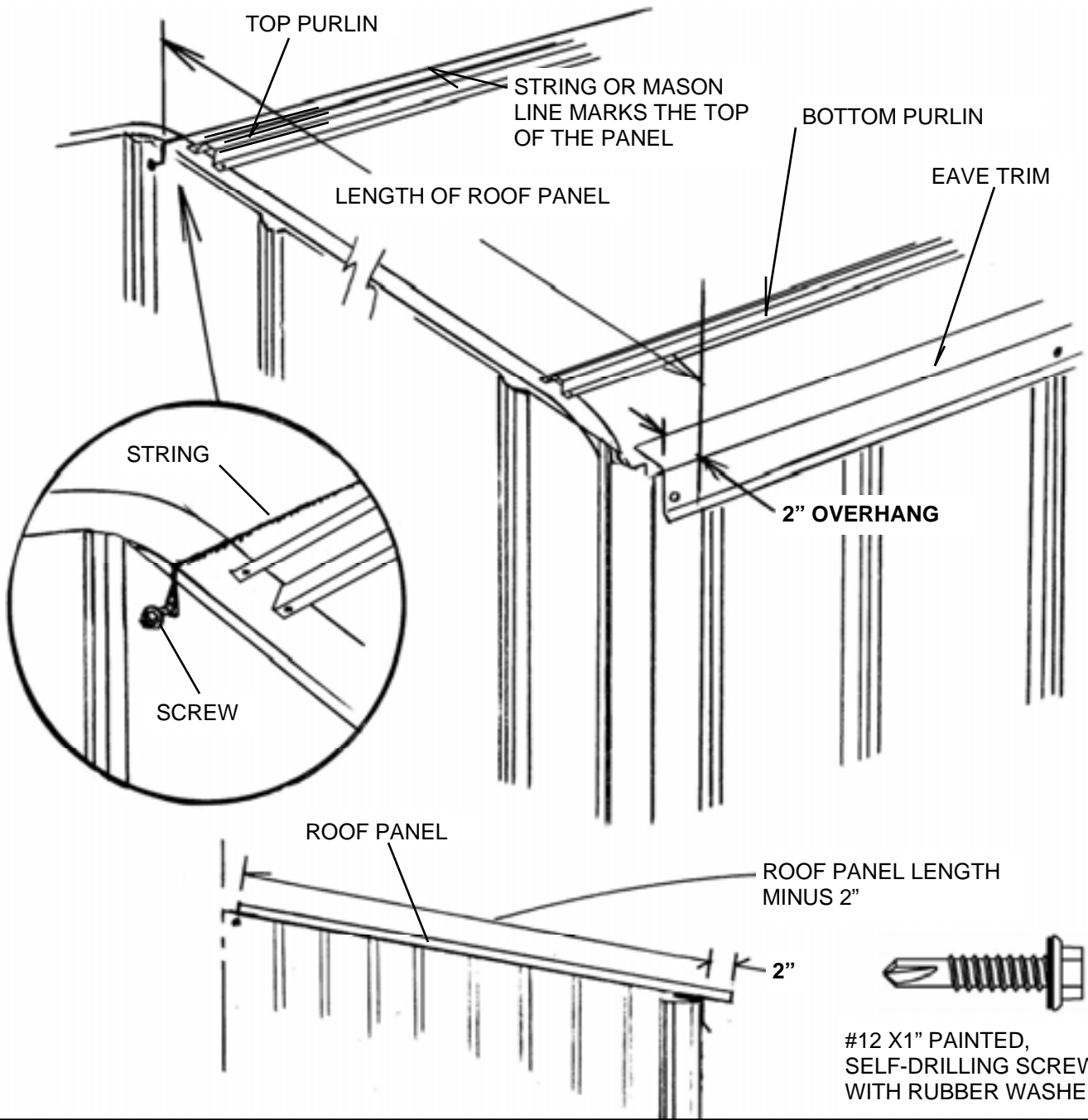

**REMAINING SCREWS**

When all roof panels have been installed climb onto the roof. Step only on flat areas next to frame sections or purlins. Install the remaining screws. (use one screw next to each major rib.)

Do not step on major ribs.

## STEP 20: INSTALLING GABLE TRIM

GABLE TRIM WILL COME IN 10' OR 14' LENGTHS.

Gable Trim will finish the joints at the gable ends of the building between the roof and the end wall panels.

Clip one piece of gable trim in the front center and the top back flange as shown. Fold the trim so the front flanges overlap. This will go at the peak of the building. If you have a 12' wide building and 14' trim you will need to trim the ends of the peak flush with the lower edge of the roof sheet metal panels. If you have 10' trim, you will need to cut 4 short pieces to lap under the ends of the peak pieces. The ends should be flush with the lower edge of the roof panels. If you have a 20', 24', or 30' wide building you will have additional trim pieces that can be cut (or not) to create extensions which will under lap the peak trim at both ends. The lower ends of the gable trim extensions should be set flush with the lower edge of the roof panels. The rest can lap under the peak piece. You should allow enough under lap to have vertical ribs on the front or back of the building to fasten screws into.

On a 30' wide buildings you may need 2 trim extensions on each side of the peak depending on the length of the trim in your kit. Remember, the lower edge of the gable trim should be flush with the lower edge of the roof panels.

Before you install the Gable Trim, run a bead of Butyl Sealant down the major rib of the end roof panels. Place the Butyl Sealant just to the inside of the center of the rib. (See Detail) Run the bead the full length of each gable end roof panel. If you have a building length that is not divisible by 3, one end of the building will not have a major rib on which to place the butyl caulk. In this case place the caulk on top of the 1/4" high minor rib closest to the end of the building.

Fasten the Gable trim to the Roof and End panels with 1" painted, self-drilling screws into the top of every other major rib on the front face and about 24" apart on the roof.

Keep the front of the trim flush with the front of the building and the top flush with the roof. If your trim has a step down or alternative edge on the roof, run the caulk under that edge flange and fasten the trim through the flange.

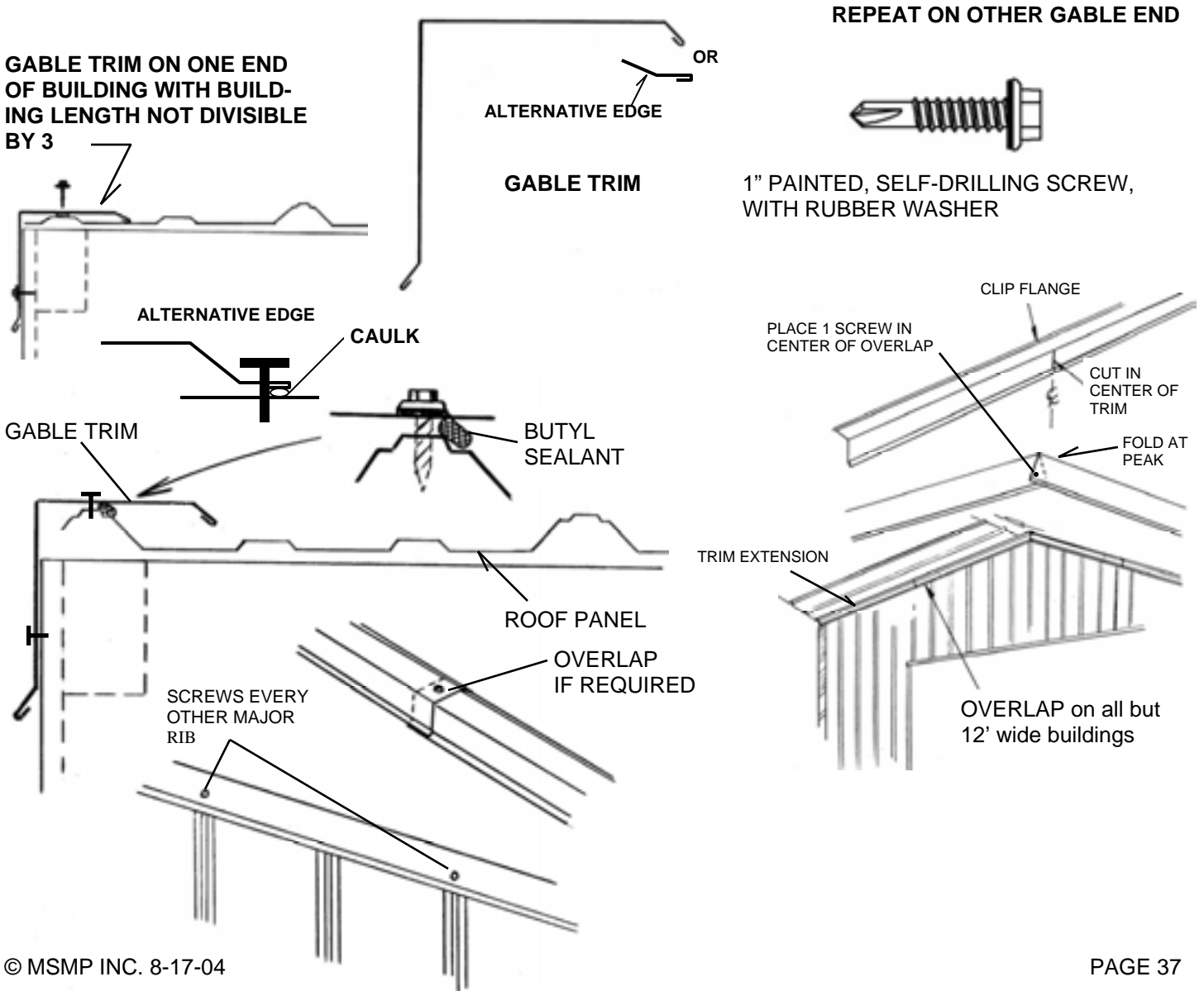

## STEP 21: INSTALLATION OF RIDGE CAP

RIDGE CAP WILL COME IN 10'-6" LENGTHS. YOU WILL OVERLAP PIECES 6" UNTIL YOU GET TO THE OTHER END OF THE BUILDING WHERE YOU WILL TRIM THE LAST PIECE TO FIT. THE RIDGE CAP SHOULD OVERHANG THE GABLE TRIM 1/2" AT BOTH ENDS OF THE BUILDING.

Place a piece of Ridge Cap on the peak of the building. Center it and make a mark at the lower edges at the end of the building. Do the same thing at the opposite end of the building and snap a chalk line between the marks. This will make the Ridge Cap easier to line up and provide a measuring point for locating Butyl Sealing Tape and Outside Foam Closure Strips.

Apply a bead of Butyl Sealing Tape to the roof panels the full length of the building 3/4" up from the chalk lines on both sides of the roof. Now, press Outside Closure strips to the Butyl Tape all the way down the building on both sides of the roof. The edge of the Closure should be 1/4" up from the chalk line.

Install the first piece of Ridge Cap on the peak at the back of the building. Let the Ridge Cap overhang the Gable Trim by 1/2". Fasten with 1" Painted, Self-drilling Screws through the edge flange and into the top of every other major rib. Run two beads of butyl tape at the end of the first piece of ridge cap to seal it to the next overlapping piece of Ridge Cap. Lap the next piece of Ridge Cap 6" over the first, press the seam together and so on down the building. The last piece should overhang the Gable Trim at the other end of the building 1/2".

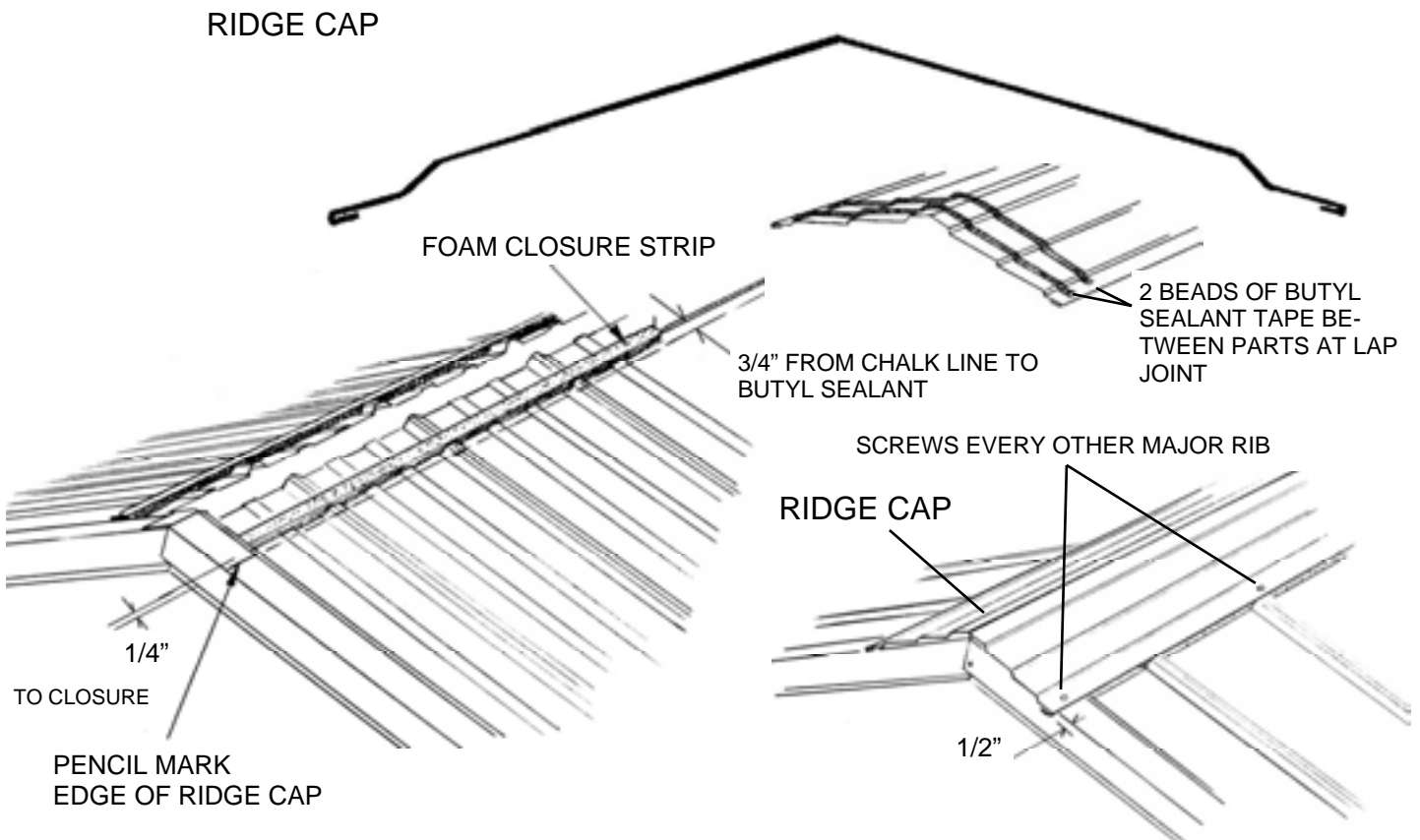

## STEP 19: INSIDE CLOSURE STRIPS AT EAVE

On the inside of the building, install Inside Foam Closure Strips between the eave trim flange and the roof panels. Peel the strips off the backing paper, pull down the eave trim flange and work the closure strips between the flange and the roof panels. The ends of the strips will interlock at a major rib. Start in one corner and work to the other.

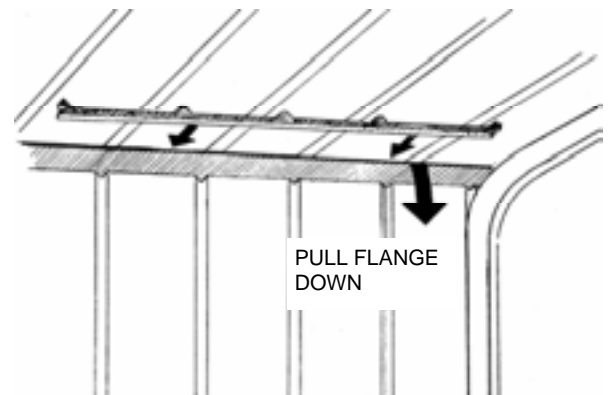

## INSTALLING YOUR GARAGE DOOR IN A VERSATUBE FRAME

Note that the Versatube frame is all steel with no overhead ceiling joist. You must deviate from the door manufacturer's instructions to install the garage door in the Versatube frame. The following is a list of the installation steps that will be different from the door manufacturer's assembly instructions:

1. It is not necessary for you to frame out your door opening with 2 x 6 lumber. Track brackets will be attached directly to the steel door frame.
2. If you have a door with torsion springs instead of a extension springs you will need to attach a center vertical over the door header.
3. You will fasten all brackets and channels to the Versatube frame with #12 self-drilling screws instead of the lag screws provided with your door.
4. The garage door manufacturer's instructions call for assembling all of the door sections one at a time and using 3" nails bent over to hold the sections in place. With the Versatube frame you will assemble only the first or bottom door section and use it as a guide to locate and attach the vertical tracks to the door opening.

**TIP: You should have two people to install the garage door.**

### Step 1 Track and Flag Brackets to Vertical Track

Install mounting brackets and flag bracket to the vertical rails according to the manufacturer's instructions.

### Step 2 Assemble Door Section 1

Assemble door section #1 according to the manufacturer's instructions including the bottom weather strip, the bottom wheel brackets and the correct hinges. Insert 4 rollers into bottom brackets and hinges and place the first door section in the door opening with the front of the door flush with the back of the door frame. Center the door side to side. One person must hold the door in place or brace it up with something on both sides.

### Step 3 Installing Vertical Door Tracks

Slide the left vertical door track onto the wheels. Use your level to plumb the track and fasten the bottom track bracket to the door frame with a #12 self-drilling screw ( the same screws used to assemble your frame).

Plumb the track and attach the next higher bracket to the door frame. Continue to plumb and attach all brackets and flag bracket to the frame with self-drilling screws. When all brackets are installed go back and install one additional screw in each bracket. Repeat this assembly for the right door track.

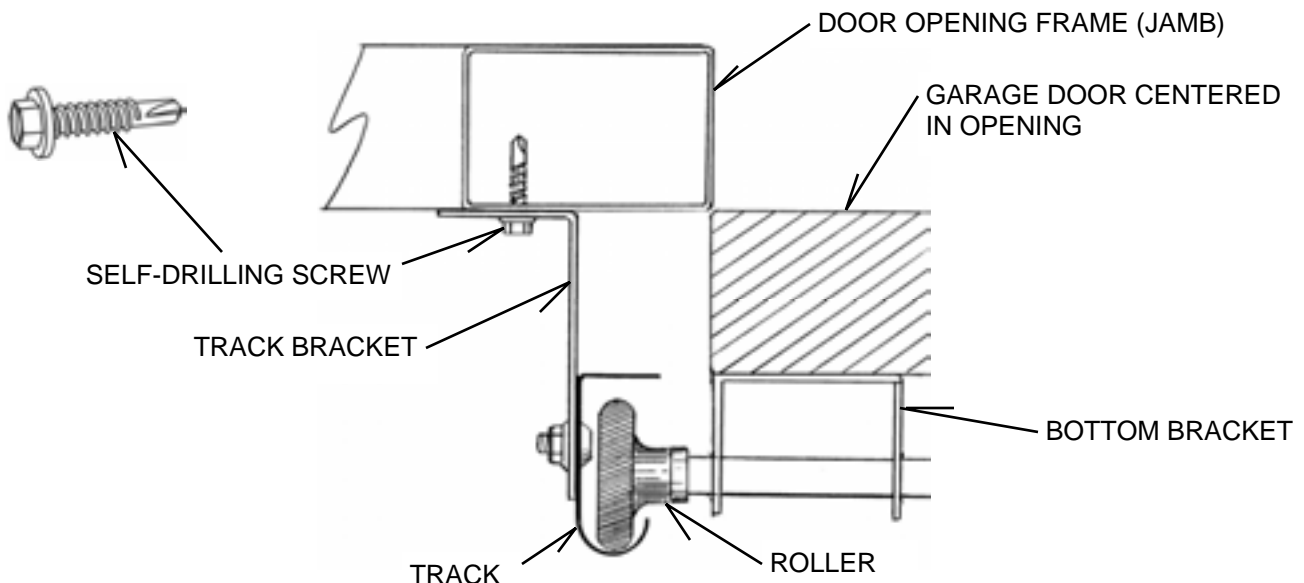

#### Step 4 Installing Additional Door Sections

Follow the door manufacturer's instructions and assemble door section 2. Note that each door section uses a different height hinge at the ends of the door and the same size hinge in the center of the door.

When the second door section is assembled, install the rollers and install the door section into the vertical door tracks sliding it down from the top of the tracks. With the section in place attach the door hinges connecting section one to section two.

Repeat this assembly for door section three. If your door is taller than 7' install all but the top section. The top section will be installed after the horizontal track (and low headroom kit if required) is installed.

If the Versatube building that you have has 4' on center frame spacing you will tie the back of the horizontal tracks up to the rafter above at the end of the tracks. If the your building has the frame sections on 5' centers you will have to add an extension piece of perforated angle (1 1/2" x 1 1/2" x 16 GA.) to your tracks. This extension will allow you to connect the vertical perforated angle to the rafter above. (See illustration on next page) Perforated angle is not provided. For 5' on center frames cut the angle lengths to 28". Measure from the back of the horizontal tracks 8 3/4" and make a mark on the outside of the track. Place the extension angle piece on the track as shown with the end of the angle extension lined up with your mark. Clamp the track and extension angle together and drill two 5/16" hole through the door track using the two of the holes in the perforated angle as a guide. (See illustration) Attach the extension angles to the door tracks with two 5/16" x 3/4" hex head bolts with split lock washers and nuts as shown. Nuts and bolts are not provided.

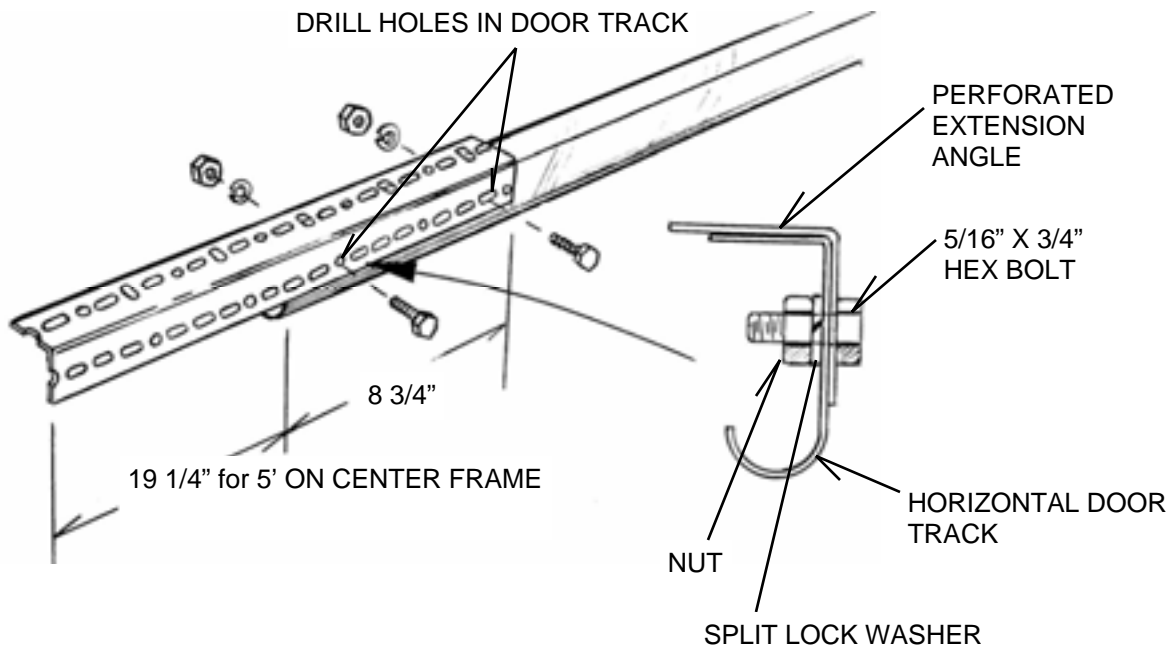

#### Step 5

Attach the Horizontal Tracks to the Vertical Tracks following the manufacturer's instructions. If you are attaching a low headroom kit you will also refer to the instructions included with that kit. To temporarily support the back of the tracks use a string tied to the back of the perforated angle extensions. You should be able to find a place to lace the string through the sheet metal and over the rafter. If you prefer, you can drive a self-drilling screw into the side of the rafter part way and tie the string to the screw.

The back of the perforated angle extension (that you attached to the horizontal tracks) will be fastened vertically to the rafter above with a piece of perforated angle and a brace piece placed at an angle. Use 5/16" x 3/4" hex bolts with lock washers and nuts (not provided) to attach the angle pieces together and #12 x 1" painted self-drilling screws with rubber washer (the same screws you used to attach the sheet metal on the building) to attach the perforated angles to the rafter above.

Note: The perforated angle and 5/16" x 3/4" hex bolts, lock washers and nuts are not provided with the garage door or conversion kit. They must be purchased separately. See illustration on next page.



## ATTACHMENT OF DOOR TRACK WITH & WITHOUT EXTENSION ANGLE TO RAFTER IN BUILDING WITHOUT A LOW HEADROOM KIT INSTALLED.

Before you start, make sure that the tracks are level and square to the front of the building. Use your level to set the track level and measure the diagonals from the back of one track to the front of the other. The diagonals must be equal. See illustration in door manufacturer's instructions.

Cut a piece of perforated angle to fit vertically as shown and fasten it to the back of the track, or the extension angle, with a 5/16" x 3/4" hex bolt, lock washer and nut. Fasten the top portion to the rafter with two Painted self-drilling screws with rubber washers (the same screws you used to attach the sheet metal to your building). Now, cut a piece of perforated angle to create an angle brace as shown and attach it to the track extension just above the extension with a 5/16" x 3/4" hex bolt, lock washer and nut. Attach the brace to the rafter with a painted self-drilling screw.

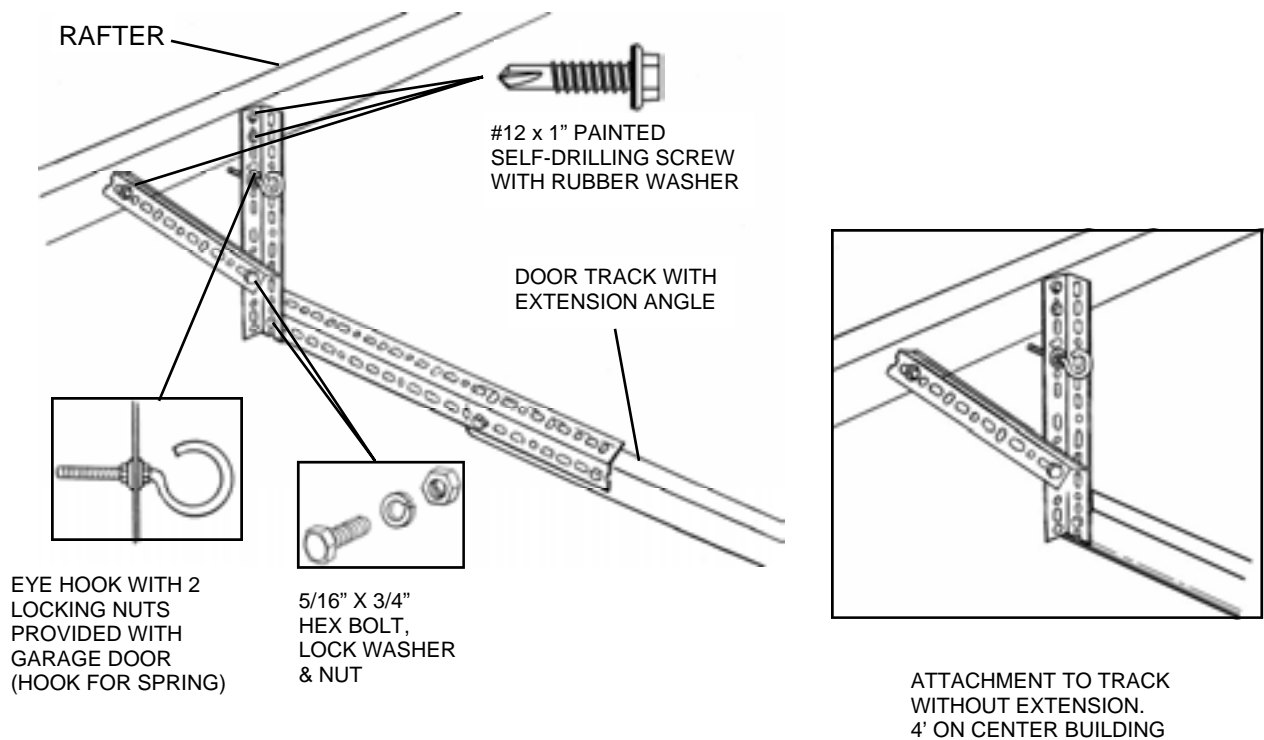

### ATTACHING THE SPRING HOOK (EYE BOLT)

The spring hook should be attached to the vertical brace about 12" above the track extension. Place a flanged, locking hex nut on the eye bolt the full extension of the threads with the flange to the rear. Insert the bolt through the vertical brace and install another flanged hex nut as shown. Tighten the nuts.

**IF YOUR BUILDING HAS FRAME SECTIONS ON 4' CENTERS, YOU WILL NOT NEED A PERFORATED TRACK EXTENSION. YOU WILL ATTACH THE END OF THE DOOR TRACK TO THE RAFTER WITH A VERTICAL BRACE AND AN ANGLE BRACE AS SHOWN ABOVE RIGHT. THE VERTICAL BRACE WILL ATTACH TO THE LARGE HOLE AT THE BACK OF THE DOOR TRACK.**

## INSTALLING THE TOP DOOR SECTION

With the door tracks installed it is now time to install the last or top door section.

Place the last door section on top of the section before. Center it side to side and clamp the bottom of the top section to the lower section or have a helper hold the bottom of the section in place while you attach the hinges connecting the sections at the center and both ends.

Take a roller, lace it into the track or low headroom track, place the top roller bracket onto the roller shaft, position the bracket on the top door section and attach it to the door with sheet metal screw. Repeat on other end of top door section.

TOP BRACKET THAT COMES WITH GARAGE DOOR. LOCATE 3 1/4" DOWN FROM TOP OF DOOR

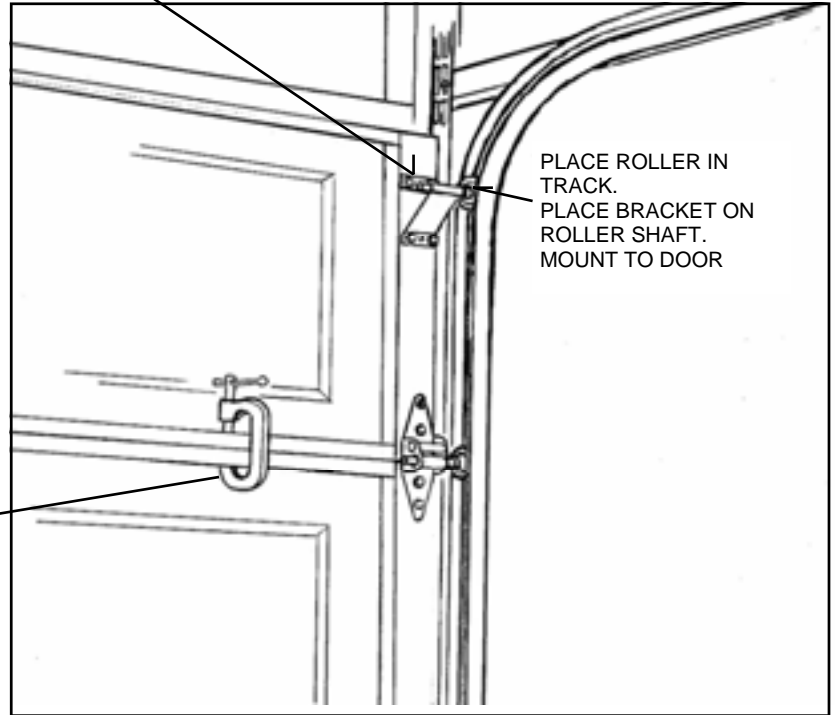

Make all necessary adjustments to the track brackets to allow the door operate smoothly. See the door manufacturer's instructions for all adjustments.

Refer to the door manufacturer's instructions for spring installation. If you have a torsion spring door, Mount the center bearing plate with #12 x 1" painted, self-drilling screws with rubber washers instead of 5/16" x 1 1/2" lag screws. Pre drill one additional 1/4" hole in the plate between the existing holes prior to mounting. Use 3 screws.

## INSTALLING DOOR SEALS

Door weather seal strips are available at most building supply stores. You will need to purchase enough to fit around the sides and top of your garage door. Weather seal strips go on the door frame (outside the door) both sides and top of the door to seal out wind and rain.

Cut one seal to fit your door header and fasten it to the Verstatube frame with painted #12 x 1" self-drilling screws with rubber washers. Place the screws about 12" apart.

Locate the weather seal strip so that the flexible seal portion presses lightly against the front of the door. Now cut to side pieces of trim to go from the bottom side of the top trim to the concrete slab. Fasten the side pieces as you did the top seal.

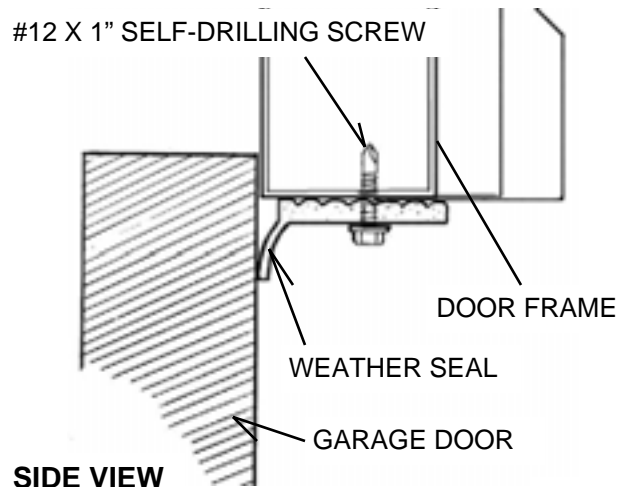

# INSTALLATION INSTRUCTIONS FOR REFLECTIVE INSULATION

If you are installing foil insulation on your building, follow these instructions along with the instructions for installing sheet metal panels. They must be installed together.

**TOOLS YOU WILL NEED:** Utility Knife, Measuring Tape, Stapler (A desk stapler will work but we recommend a Plier Stapler.)

Reflective insulation is designed to provide a moisture barrier and some insulation to a metal clad building. This 1/4" thick insulation is designed to be applied to the outside of the building frame before the sheet metal panels are installed. The insulation will be installed along with the sheet metal panels. Insulation is held in place on the frame with double sided adhesive tape. The sheet metal panels are installed over the insulation as you go with #12 x 1" painted self-drilling screws with rubber washers. By installing the panels as you install the insulation you will prevent any wind damage to the insulation.

The insulation comes in 50" wide rolls and is designed to give 48" of coverage in width. One edge has an adhesive strip which will be used to attach one section of insulation to the next. The adhesive strip is on the white side of the insulation. The white side of the insulation will face the inside of the building.

Note: The order in which you install the insulation is the same as the sheet metal panels because they are installed together.

## STEP 1: INSULATION ON THE SIDES OF THE BUILDING

Take a measurement from the bottom of the base rail to the top edge of the first roof purlin or hat channel and cut a length of insulation to match. You might want to cut the first piece a little long and put it in place on the building to check the fit. Adjust your dimension and cut all other side insulation panels to the adjusted length.

Run a strip of double sided tape along the top of the first purlin or hat channel on the roof and also along the base rail or bottom side hat channel. You may also want to place a couple of short strips of tape on the vertical frame tubes as well. Line the top edge of the insulation up with the top edge of the roof purlin and the corner of the building. The white side of the insulation should be to the inside of the building. The edge of the insulation without the adhesive strip should line up with the ends of the hat channel or centered on the end frame member of the building. See notes and illustration on next page for trimming around doors and windows.

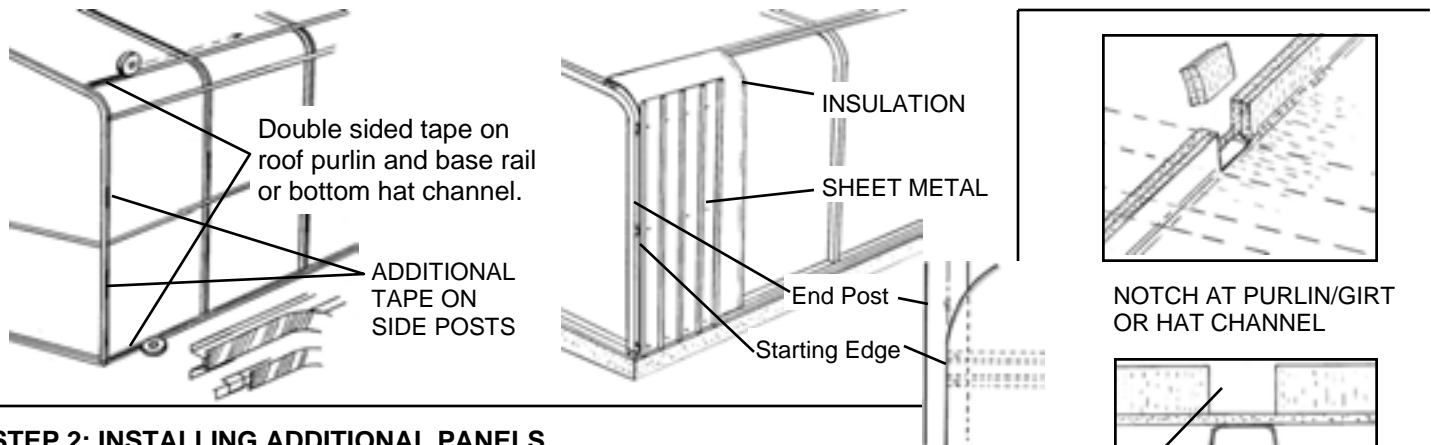

## STEP 2: INSTALLING ADDITIONAL PANELS

One edge of the insulation has an adhesive strip and one edge does not. You should have placed the side without the adhesive strip at the end of the building placing the edge with the adhesive strip in place to receive the next piece of insulation. Peel off the protective paper and fold the strip outward and stick it to the non adhesive edge of the next sheet of insulation which should also be folded outward. Start at the bottom and work your way up to the top. Whenever the seam crosses a hat channel or purlin tube use your utility knife to cut out a notch in the insulation to allow the insulation to fit closer to the frame and not create a bulge in the sheet metal panel.

You can get the seam to fold easier around the eave corner by making a few cuts in the seam. Staple seam every 12". Trim insulation at end of building.

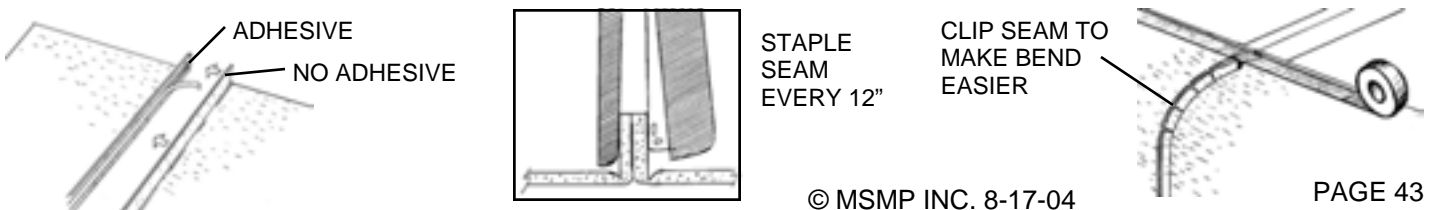

**NOTE: TRIMMING AROUND DOORS AND WINDOWS**

Insulation must be trimmed around doors and windows. Using your utility knife, trim the insulation even with the edge of the J-Trim back flange and tape it in place with seam tape. You must leave room for the sheet metal panels to fit into the J-Trim.

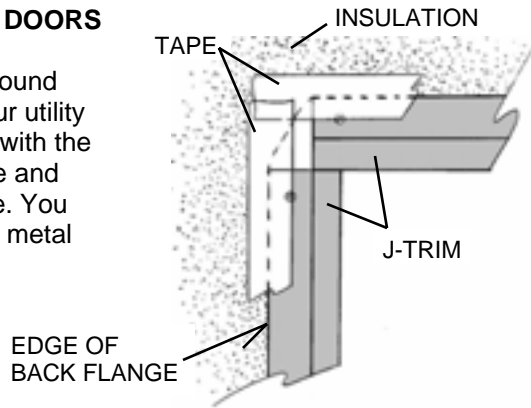

NOTE: You can join the ends of the insulation by making square cuts on both pieces to be joined and taping the seam with seam tape found in your kit. Use seam tape to clean up loose edges and any other application where a single sided tape will do the job.

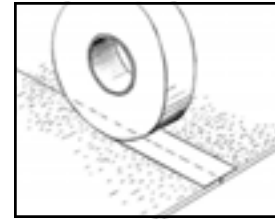

**STEP 3: INSTALLING FRONT AND BACK INSULATION**

Measure and cut pieces of insulation slightly longer than you need to run from the base rail or door header to the roof frame. Install double sided tape on the front of the roof frame and the base rail or door header and spots in-between. Press the insulation panels to the frame, trim along the top of the roof frame and install sheet metal panels as instructed in your building assembly instructions. On 12' and 20' wide buildings start with a panel of insulation centered in the end of the building. On 24' and 30' wide buildings start with the seam of two insulation panels centered in the building end. Sheet metal panels are installed from the center to both sides.

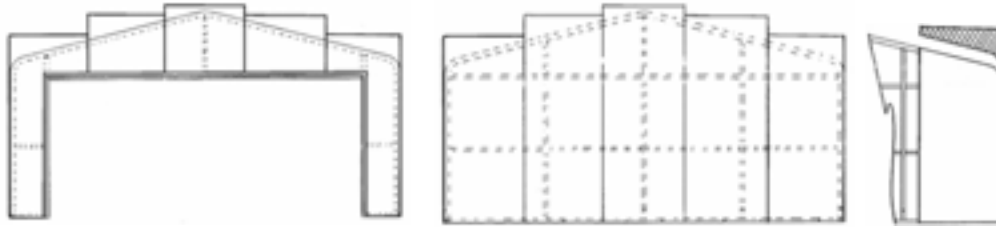

ILLUSTRATIONS SHOW A 20' WIDE BUILDING

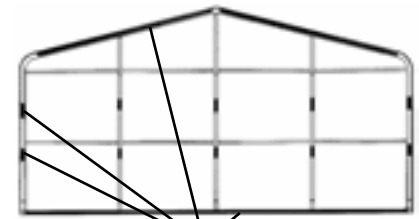
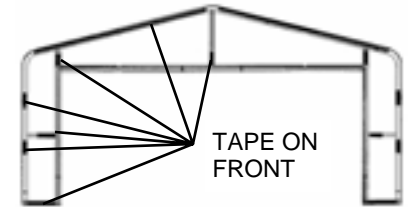

TAPE ON BACK

**STEP 4: INSTALLING INSULATION ON THE ROOF**

Starting on one side of the roof at the same end of the building that you started the side panels. Install double sided tape on top of the side insulation as shown. You should notch out a 2" section of the side insulation seam to get the tape to lay down properly. Run another strip of double sided tape on the top hat channel or roof purlin on the other side of the roof. Measure and cut insulation to fit from the side insulation to the top hat channel or purlin on the other side of the roof. Cut the insulation a little long. You can trim later if you like. Line up the edge without the adhesive strip with the center of the end frame tube as you did the side panels and press the insulation in place. (Remove slack in the insulation as much as possible.) Install additional panels as you did the sides of the building. Install Sheet metal panels as you go according to the building installation instructions.

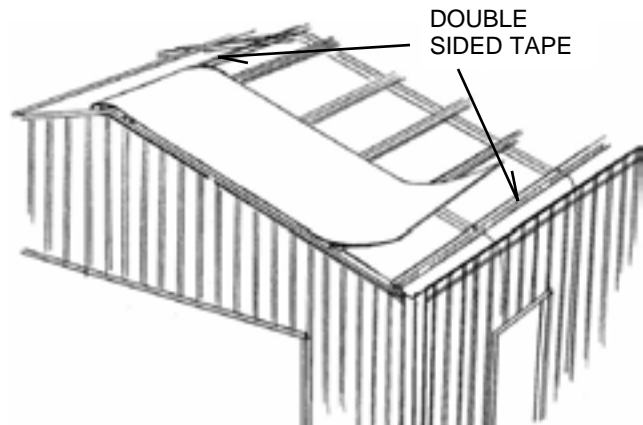

On the other side of the roof, run double sided tape on the top of the side insulation and on the top edge of the roof insulation from the other side of the roof. Measure and cut insulation to extend slightly over both strips of tape. Line the edge of the insulation without an adhesive strip up with the center of the end frame tube as you did the sides and press the insulation in place. Install sheet metal as you go. Trim off excess insulation at the end of the building.

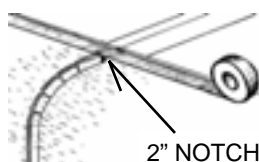
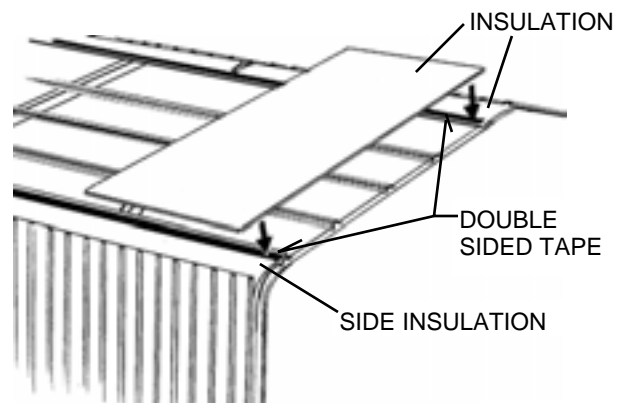

2" NOTCH IN SEAM FOR TAPE