

CONNECTIONS



TOILET



SINK

APPLICATION



RESIDENTIAL



PUMPING DISTANCE

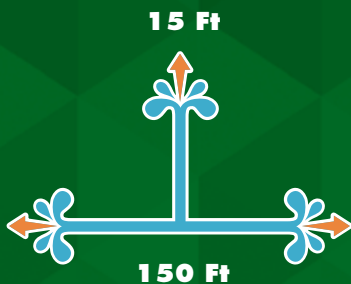

INSTALLATION BEHIND THE TOILET



Example of installation. Follow local plumbing codes for actual install.

INSTALLATION BEHIND THE WALL



Example of installation. Follow local plumbing codes for actual install.

The **Saniaccess2** is a **1/2 HP pump system** used to install a half-bathroom up to **15 feet below the sewer line, or even up to 150 feet away** from a soil stack. It incorporates a **macerating system** which can handle human waste and toilet paper in residential applications. The blade is made out of a hardened stainless steel material which **eliminates the need for any service or replacement**.

- **Discharges the waste through a 3/4" or 1" rigid pipe. A non-return valve is included** on the discharge elbow assembly provided with the system. This elbow can be rotated 360 degrees depending on the discharge installation.
- Has been designed with a **1-1/2" vent connection** on the side of the pump housing. All plumbing codes require connection to a vent system. Please note that the vent system should be a two-way air vent as air needs to freely flow both ways. Note: The use of mechanical vents, air admittance valves or similar devices is not permitted.
- Must be connected to **Saniflo's 1.28 GPF / 4.8 LPF rear discharge toilet**. These toilets come in round and elongated (ADA compliant) models. More technical information on page 6.
- Will also discharge **gray water from a sink**. The wastewater will drain into the system via a 1-1/2" inlet which is located on the side of the pump housing. Note that either side connection can be used for the vent or as an inlet.
- Designed with two **easy access service panels** located on top of the pump. On one side of the pump you can easily access the **electrical components and the level sensor**. The other side allows access to the macerating blade for **easy removal of foreign objects**.



Toilet Tank

(Part N° 005)

Insulated 1.28 GPF / 4.8 LPF toilet tank equipped with all internal valves. For more information, please turn to page 6.

Round/Elongated Bowl

(Part N° 083 or 087)

Rear discharge toilet with 16-3/4" seating height (Elongated bowl is ADA compliant). For more information, please turn to page 6.

Extension Pipe

(Part N° 030)

18" long PVC pipe with internal gasket used to hide the pump behind the wall. For more information, please turn to page 51.

Saniaccess 2

(Part N° 081)

Macerating pump for residential applications. Ideal for creating a half-bathroom in a basement, attic, garage, pool house, etc.

PLEASE CALL US TOLL-FREE AT
800-571-8191 (US) / 800-363-5874 (CDN)
 TO PURCHASE PARTS REFERENCED BELOW

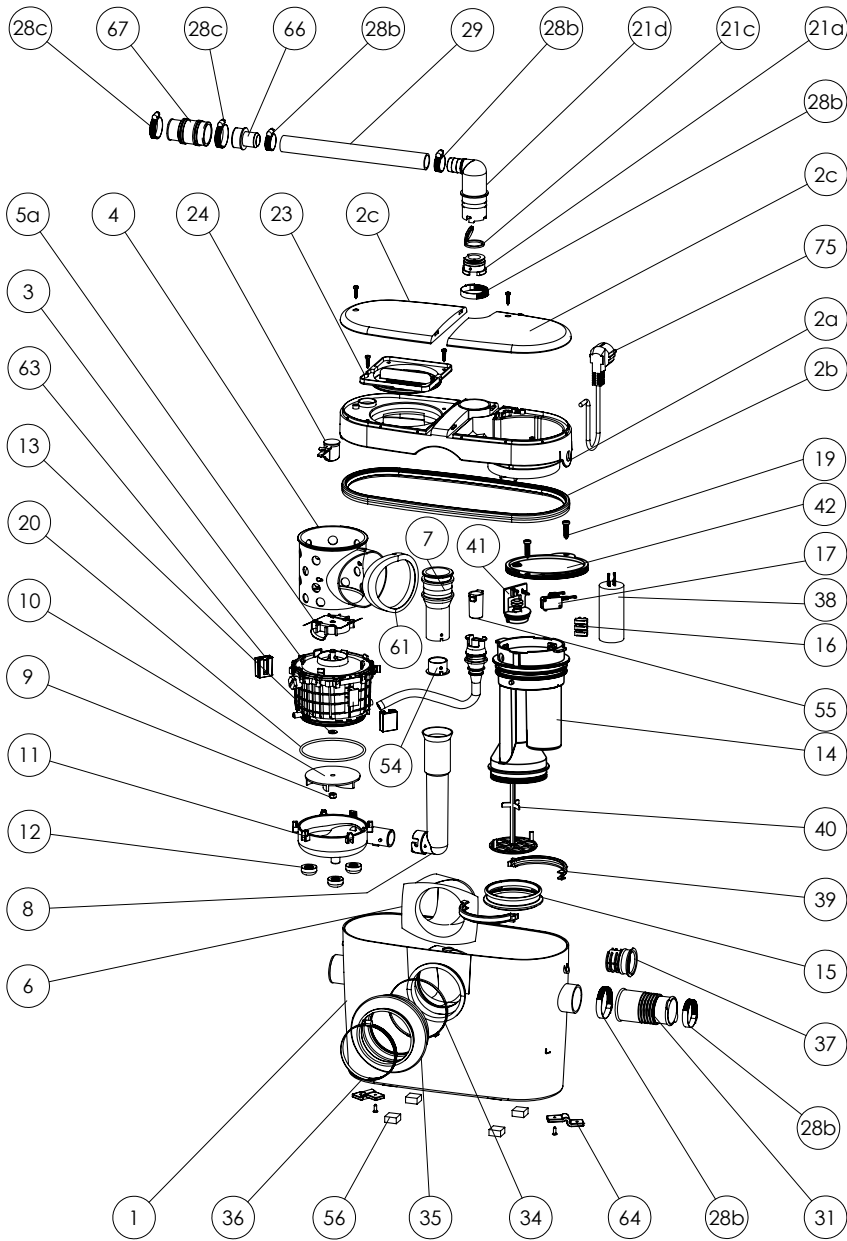

DIMENSIONAL DRAWINGS

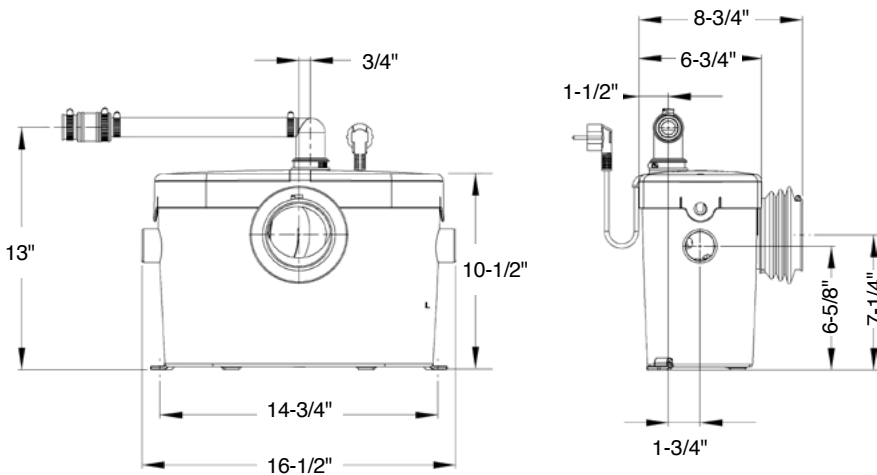

Choose any sink and enjoy your dream half-bathroom.

TECHNICAL SPECIFICATIONS

Pump type:

Macerator

Electrical:

120 V – 60 Hz / 4.5 Amps (Max)

Motor:

0.5 HP oil-filled thermally protected motor

Capacitor rating:

45 microfarad

Operating Temperature:

104°F (110°F Max.)

Power cord length:

51 inches

Noise level:

≤ 53 dBA (Lp) (measured at 3 ft.)

Discharge pipe diameter:

3/4" or 1"

Discharge rate at 15 ft:

17 GPM

Discharge rate at 3 ft:

27 GPM

Shut-off head:

30 ft.

Normal running time:

10-12 seconds

Capacity:

2.3 gallons / 8.7 liters

Inlets:

1-1/2" (side), 1-1/2" vent (side)

Method of activation:

Membrane/microswitch

Weight:

15 lbs / 6.8 kg

Certifying agencies:

CSA (IPC, NSPC), IAPMO (UPC)

Recommended accessories:

Descaler

Connections:

Rear outlet toilet, sink

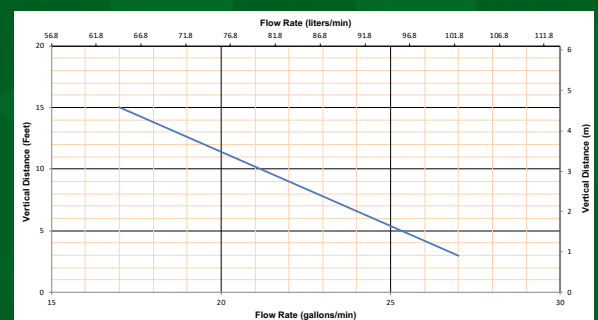



SANIFLUSH TWO-PIECE ELONGATED TOILET SYSTEM

ADA Compliant Close-Couple Toilet – 1.28 GPF (4.8 Liter Flush)

SANIFLUSH 087 & 005

✓ **087 Elongated Bowl**

- Vitreous china
- Integral P-trap and a rear outlet spigot
- Seating height: 16-3/4" (ADA Compliant)
- Large 3" trapway
- Wash down style toilet
- Low flush toilet; it uses 1.28 gallons (4.8 L) per flush
- Toilet supplied with a set of lag screws, plastic anchors and china protectors
- Water spot measures 4 1/2" x 3 3/4"
- 1 Year limited warranty

✓ **005 Toilet Tank**

- Vitreous china
- Insulated tank to prevent condensation
- The zero re-fill fill valve is easily adjustable
- The flush valve has a silicone flapper seal
- Tank is not designed to be used with refill hose thus not provided.
- Water level mark applied to the overflow tube
- Toilet tank supplied with bowl screws, washers and wing nuts
- 1 year limited warranty
- Warranty for fill and flush valve as per manufacturer

Nominal Dimensions

31" x 17-3/4" x 28-3/4"
(787mm x 451mm x 730mm)

Fixture Dimensions and Hydraulic Performance - Meets or Exceeds the Following Specifications

- ANSI/ASME A112.19.2M and CAN/CSA B45 Requirements
- IAPMO/UPC Certificate of Listing
- EPA WaterSense labeled

Notes

- Available in white only
- Includes soft-close toilet seat along with mounting hardware kit (Part# US3ESEAT)
- Replacement fill valve recommended – Fluidmaster 400A or equal (not supplied)



Elongated Bowl with Tank (087 & 005)

Care & Cleaning

- When cleaning toilet, wash it with mild soapy water or liquid cleaners that are not chlorine or bleach based. Avoid using harsh detergents.
- We do not recommend the use of in-tank cleansers. Products containing chlorine can cause damage to components inside the tank and cause them to fail prematurely.



MEETS THE AMERICAN WITH DISABILITIES ACT GUIDELINES AND ANSI A117.1 REQUIREMENTS FOR ACCESSIBLE AND USABLE BUILDING FACILITIES. CHECK WITH LOCAL CODES.





SANIFLUSH TWO-PIECE ELONGATED TOILET SYSTEM

ADA Compliant Close-Couple Toilet – 1.28 GPF (4.8 Liter Flush)

SANIFLUSH 087 & 005

Drawings and Dimensions

