

Use Instructions

1. Pull up on AIRLIFT® lever and desktop to lift.
2. Pull up on AIRLIFT® lever and press down on desktop to lower.

FAQS

Q. Can I attach a monitor stand to it? What about dual monitors?

A. Yes! Be sure the desk is below it's 22 lbs. weight limit.

Q. What size is the base?

A. Base measures 18 inches wide and 19 inches deep.

Q. Do I need to plug it in?

A. Nope! It's fully pneumatic. Simply unpack and go.

Specifications

Top dimensions: 30.7" W x 18.9" L

Tray dimensions: 30.7" W x 7.87" L

Base dimensions: 18" W x 19" L

Overall dimensions: 30.7" W x (20.5" to 27.2") L x (6.9" to 17.9") H

Maximum weight on tray: 5 lbs. (2 kg.)

Maximum weight overall: 22 lbs. (10 kg.)

Customer Service Information

Telephone: (800) 323-5565

Fax: (310) 533-3899

Hours: 8:30 AM – 4:30 PM (PST)

Email: Support@SevilleClassics.com

Homepage: www.SevilleClassics.com



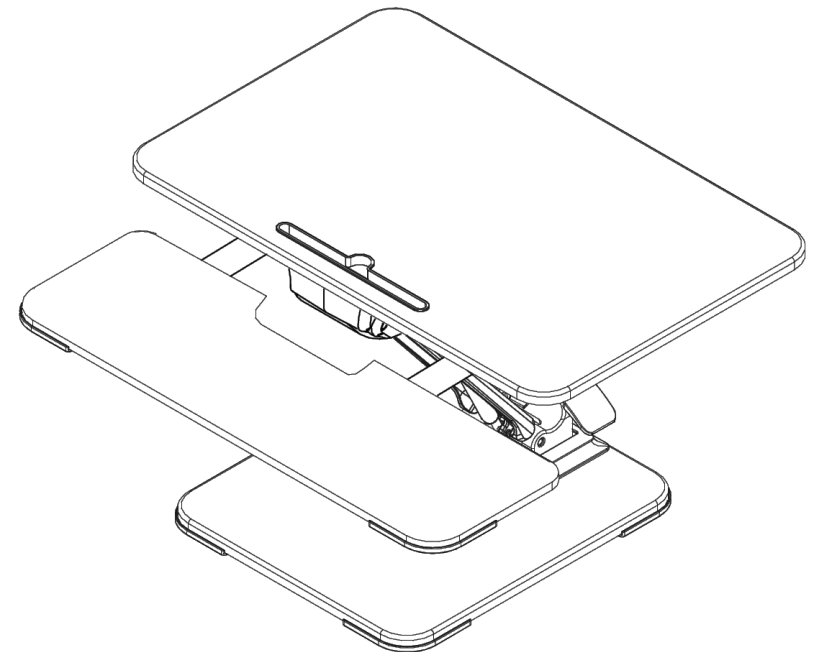

30" Compact Gas-Spring Aluminum Standing Desk Converter



Model: OFF65841, OFF65901, WEB583, WEB635

Thank you for choosing Seville Classics! We hope that you enjoy your standing desk converter! Please read through this user guide for parts list, assembly instructions, frequently asked questions and further contact information.

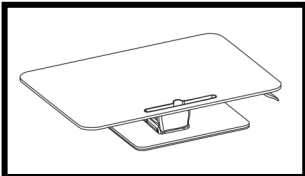
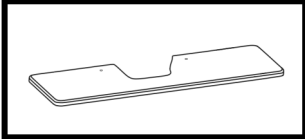
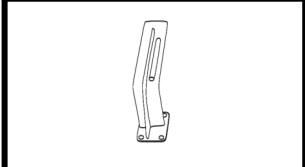
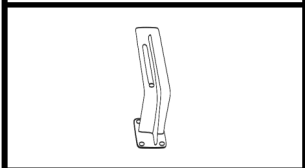
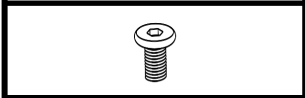
Parts List

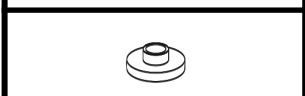
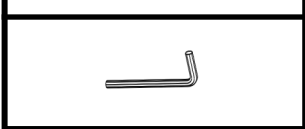
A. Desk (1)	
B. Tray (1)	
C. Left Bracket (1)	
D. Right Bracket (1)	
E. Short Screw (8)	
F. Long Screw (2)	
G. Anchor (2)	
H. Hex Wrench (1)	

Please make sure you have all the parts on this list.

If you're missing parts, contact us for replacements at (800) 323-5565 or send an email to Support@SevilleClassics.com

Safety



Failure to follow these instructions may result in property damage or personal injury.



DO NOT place devices on desk edge.



DO NOT route wires underneath desk.



MAKE SURE devices have cables long enough for the full-range (11.8 in/29.9 cm) of height-adjustment.



DO NOT quickly lift desktop when loaded.

Adjust to the ideal height for use while sitting or standing.

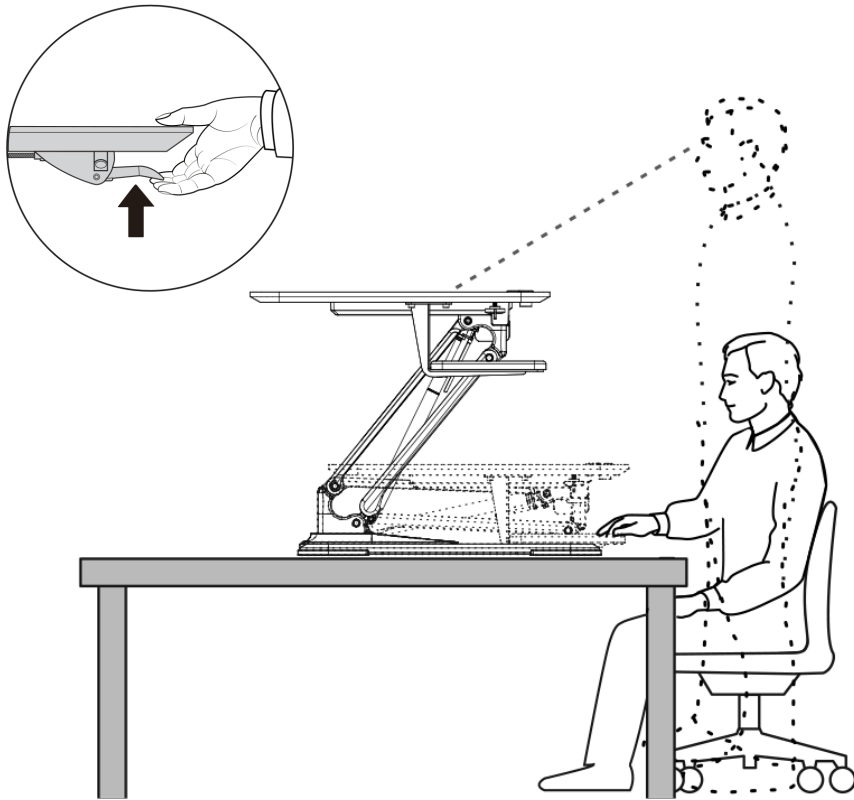

Slide keyboard tray underneath the desk top when not needed.

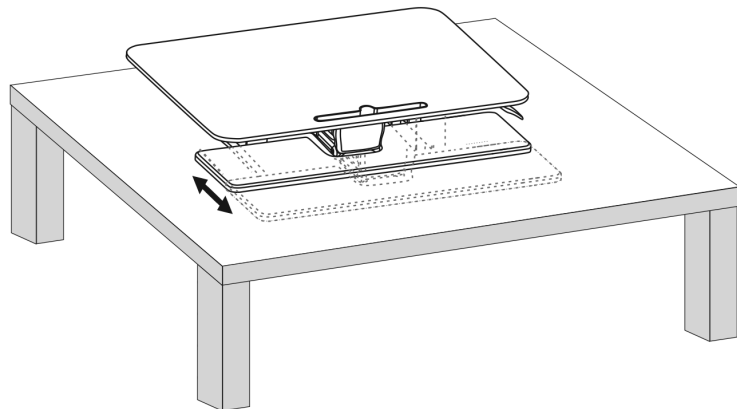

Assembly Instructions

STEP 1. Turn **TRAY (B)** upside down.

Position **LEFT BRACKET (C)** over mounting holes on left side of tray.

Insert **ANCHOR (G)** through **BRACKET (C)** and into **TRAY (B)**.

TIP: Make sure the mounting holes on the **BRACKETS (C, D)** face the inner side of the tray.

Attach with **LONG SCREWS (F)**.

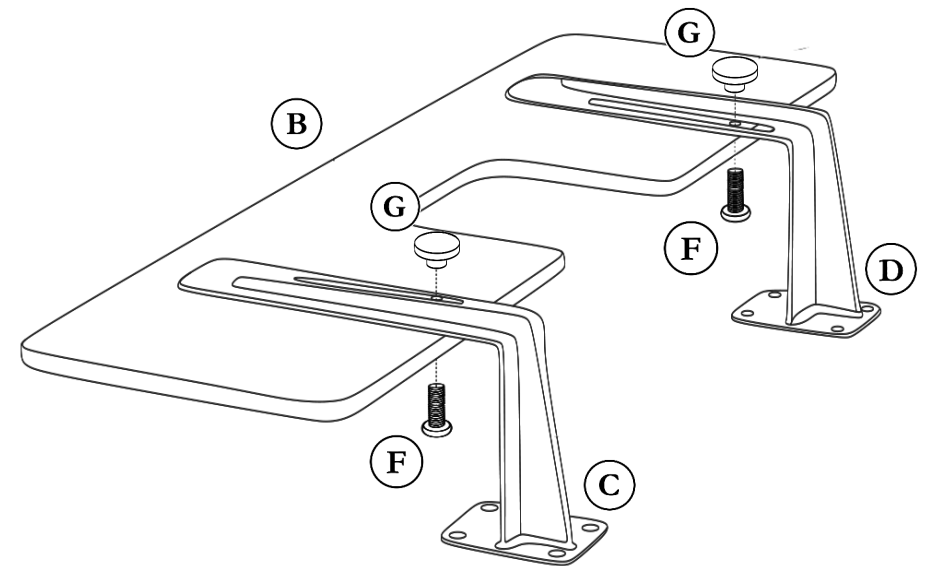

Repeat for **RIGHT BRACKET (D)**.

STEP 2.

Squeeze AIRLIFT® lever and pull up on both sides of the desk to lift.

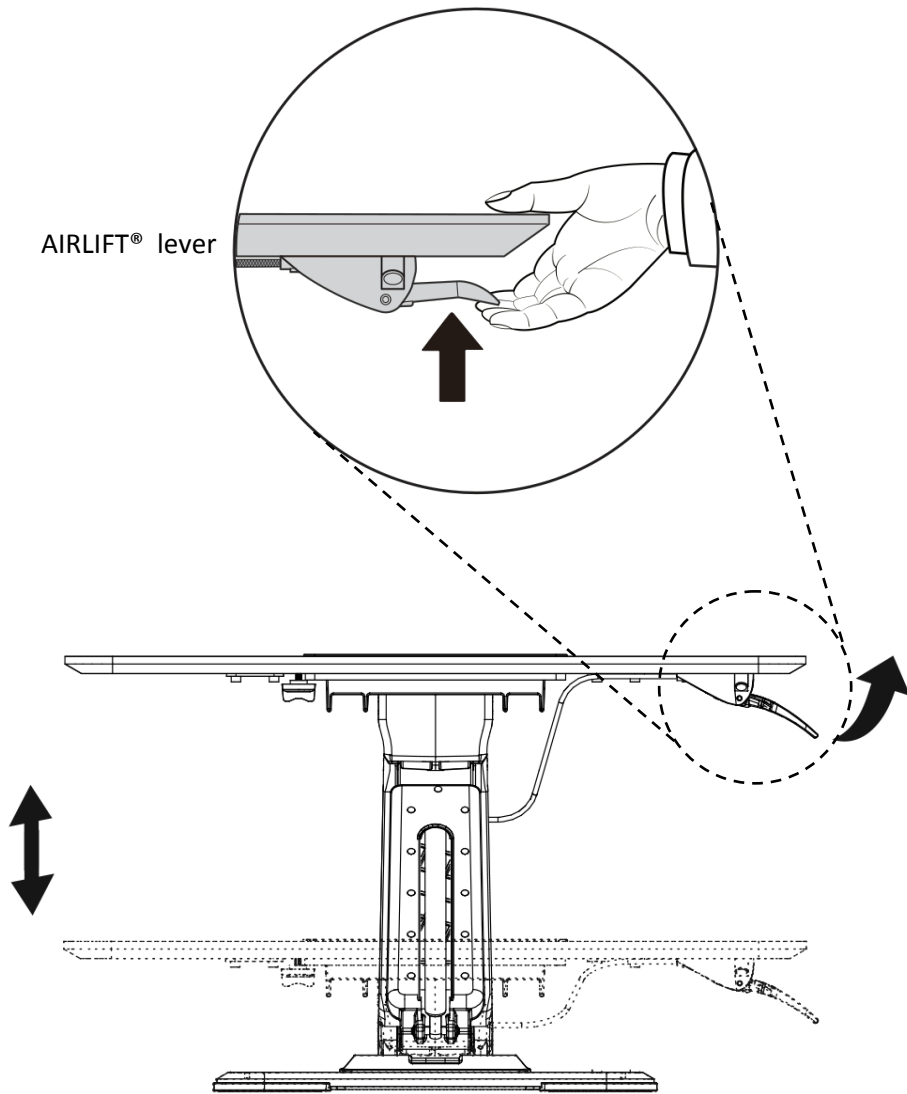

3

STEP 3.

Turn **DESK (A)** upside down.

Align **BRACKETS (C, D)** to holes on bottom of desk top.

Attach with **SHORT SCREWS (E)** using **HEX WRENCH (H)**.

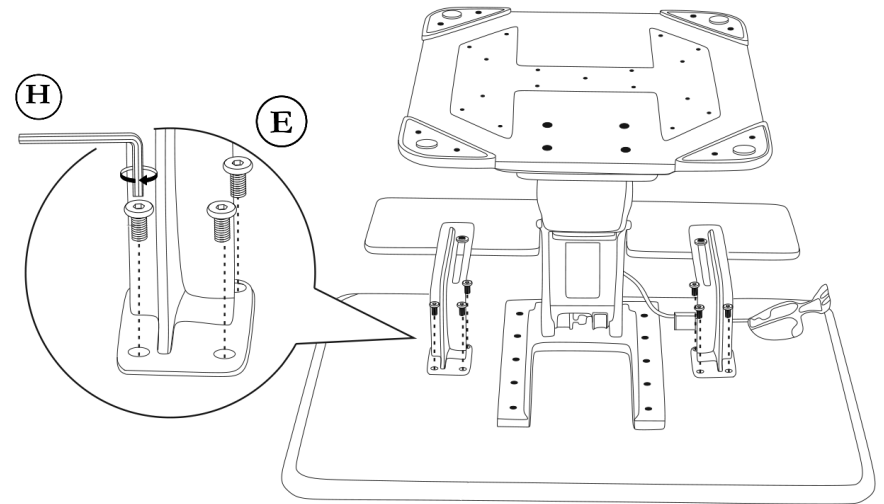

STEP 4. Turn onto base to finish.

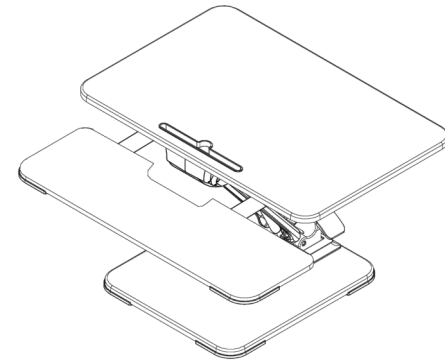

Congratulations! Enjoy your new AIRLIFT Standing Desk!



WARNING: DO NOT PLACE HANDS ON
DESK LEGS. MOVING PARTS CAN CRUSH.



4