

## OIL FIRED WATER HEATER



**WARNING:** If the information in these instructions is not followed exactly, a fire or explosion may result causing property damage, personal injury or death.

- Improper installation, adjustment, alteration, service, or maintenance can cause injury or property damage. Refer to this manual. For assistance or additional information, consult a qualified Oil-Burner Technician or your oil supplier.
- Do not store or use gasoline or other flammable vapors and liquids in the vicinity of this or any other appliance.
- Installation and service must be performed by a qualified Oil-Burner Technician or your oil supplier.
- **WHAT TO DO IF YOU SMELL OIL:**
  - Immediately call your oil supplier. Follow the oil supplier's instructions.



### **⚠ WARNING**

Read and understand instruction manual and safety messages before installing, operating or servicing this water heater.

Failure to follow instructions and safety messages could result in death or serious injury.

Instruction manual must remain with water heater.

**ALL TECHNICAL AND WARRANTY QUESTIONS:** SHOULD BE DIRECTED TO THE LOCAL DEALER FROM WHOM THE WATER HEATER WAS PURCHASED. IF YOU ARE UNSUCCESSFUL, PLEASE CONTACT THE COMPANY LISTED ON THE RATING PLATE ON THE WATER HEATER.

**KEEP THIS MANUAL IN THE POCKET ON HEATER FOR FUTURE REFERENCE  
WHENEVER MAINTENANCE ADJUSTMENT OR SERVICE IS REQUIRED.**



## TABLE OF CONTENTS

<p>I) Introduction .....3              Consumer Responsibilities.....3</p> <p>II) Safety.....5              Installation Codes.....5              Safety Warning (Flammable Vapors).....5              Safety Warning (Scalding).....5              Safety Warning (Carbon Monoxide).....6              Relief Valve Requirements (T&amp;P).....6              Fuel Specifications.....7</p> <p>III) Installation .....7              Unpacking the Water Heater .....7              Location Requirements .....7                  In Earthquake Zones              Clearances and Accessibility .....8              Oil Supply.....8              Burner Installation .....8              Air Requirements .....11                  Unconfined Space                  Confined Space                  All Air from Inside the Building                  All Air from Outdoors                  Louvers and Grilles              Vent and Exhaust Connections .....13                  Vent Pipe System                  General Chimney Requirements                  Flue Pipe                  Draft Regulator                  Chimney                  Blocked Vent Safety Switch                  Installation                  Power Venting                  Installation Of Power Venter              Water Supply .....15                  Piping Installation                  Mixing Valves                  Closed System/Thermal Expansion                  Temperature And Pressure (T&amp;P) Relief Valve                  The Temperature And Pressure Relief Valve:                  The Discharge Line/Driptide:                  Temperature-Pressure Relief Valve And Pipe                  Insulation                  Vacuum Relief Valves                  Installation Of The Aquastat (Temperature Control)              Electrical Supply.....18                  Filling The Water Heater              Installation Checklist.....19</p>	<p>IV) Operation .....19              Startup .....19              Water Temperature Regulation.....20              Water Heater Operation .....21                  Stacking                  Water Heater Sounds                  Smoke/Odor                  Anode Rod/Water Odor</p> <p>V) Maintenance .....21              Professional Maintenance              Flue Pipes              Combustion Tests              Routine Preventative Maintenance (By Owner/              Operator)              Draining And Flushing              Temperature And Pressure Relief Valve              Anode Maintenance              To check/replace the anode:              Valve Washer Replacement              Cleaning Instructions, Flue Passages Of The              JW F657 Heater              Shut Down For Extended Periods              Re-Starting The Heater After Shut-Down</p> <p>VI) Combo Heating .....25              Read Before Proceeding .....25              Installation .....25</p> <p>VII) Oil Burner Listing .....27</p>
--	--

**RETAIN THESE INSTRUCTIONS IN A SAFE LOCATION FOR FUTURE REFERENCE**

Your safety and the safety of others is extremely important in the installation, use and servicing of this water heater. Many safety-related messages and instructions have been provided in this manual and on your own water heater to warn you and others of a potential injury hazard. Read and obey all safety messages and instructions throughout this manual. It is very important that the meaning of each safety message is understood by you and others who install, use or service this water heater.

	This is the safety alert symbol. It is used to alert you to potential personal injury hazards. Obey all safety messages that follow this symbol to avoid possible injury or death.
---	--

 <b>DANGER</b>	<b>DANGER</b> indicates an imminently hazardous situation which, if not avoided, will result in death or injury.
 <b>WARNING</b>	<b>WARNING</b> indicates a potentially hazardous situation which, if not avoided, could result in death or injury.
 <b>CAUTION</b>	<b>CAUTION</b> indicates a potentially hazardous situation which, if not avoided, could result in minor or moderate injury.
<b>CAUTION</b>	<b>CAUTION</b> used without the safety alert symbol indicates a potentially hazardous situation which, if not avoided, could result in property damage

All safety messages will generally tell you about the type of hazard, what can happen if you do not follow the safety message and how to avoid the risk of injury.

The California Safe Drinking Water and Toxic Enforcement Act requires the Governor of California to publish a list of substances known to the State of California to cause cancer, birth defects or other reproductive harm and requires businesses to warn of potential exposure to such substances.

This product contains a chemical known to the State of California to cause cancer, birth defects or other reproductive harm. This appliance can cause low level exposure to some of the substances listed in the Act.

This product is certified to comply with a maximum weighted average of 0.25% lead content as required in some areas.

## I) INTRODUCTION

**Thank you for purchasing a John Wood Oil Fired Water Heater.** Properly installed and maintained, it will provide years of trouble free service.

This Oil Fired Water Heater is suitable for potable water heating and space-heating applications but not for space heating only applications. It is your responsibility to ensure that the correct size of your water heater was determined by calculations that included consideration of heat loss.

### Consumer Responsibilities

This manual has been prepared to acquaint you with the installation, operation and maintenance of your oil fired water heater and provide important safety information in these areas. It is your responsibility to ensure that your water heater is properly installed and cared for.

**FAILURE TO FOLLOW THE INSTRUCTIONS IN THIS MANUAL MAY RESULT IN SERIOUS BODILY INJURY AND/OR PROPERTY DAMAGE. THOROUGHLY READ AND UNDERSTAND ALL INSTRUCTIONS BEFORE YOU ATTEMPT TO INSTALL, OPERATE OR MAINTAIN THIS HEATER.**

Installation and service requires trade knowledge in the areas of plumbing, electricity, venting, air supply and oil supply. If you lack these skills or have difficulty understanding these

instructions, you should not proceed. Enlist the help of a qualified service technician to install this water heater.

Examples of qualified service technicians include those trained in the plumbing and heating industry, local oil supply personnel or an authorized service person.

The manufacturer and seller of this water heater will not assume any liability for any property damage, personal injury or death resulting from improper sizing, installation or failure to comply with these instructions.

The warranty on this water heater is in effect only when the water heater is installed and operated in accordance with these instructions. An identifying data plate can be found at the front of your water heater. When referring to your water heater, always have the information listed on the data plate readily available.

Protect your warranty: Regularly service your water heater as directed in the "Maintenance" section of this manual. Retain your original receipt as proof of purchase.

Do not discard this manual. You or future users of this water heater will need it for reference.

# INSTALLATION GRAPHIC: OIL-FIRED POTABLE WATER HEATING/SPACE HEATING SYSTEM

- If your water heater will be installed in the Commonwealth of Massachusetts, refer to the following graphic during installation and during modifications to the water supply system.

TYPICAL MIXING VALVE INSTALLATION  
COMBINATION SPACE HEATING / POTABLE WATER HEATING SYSTEM

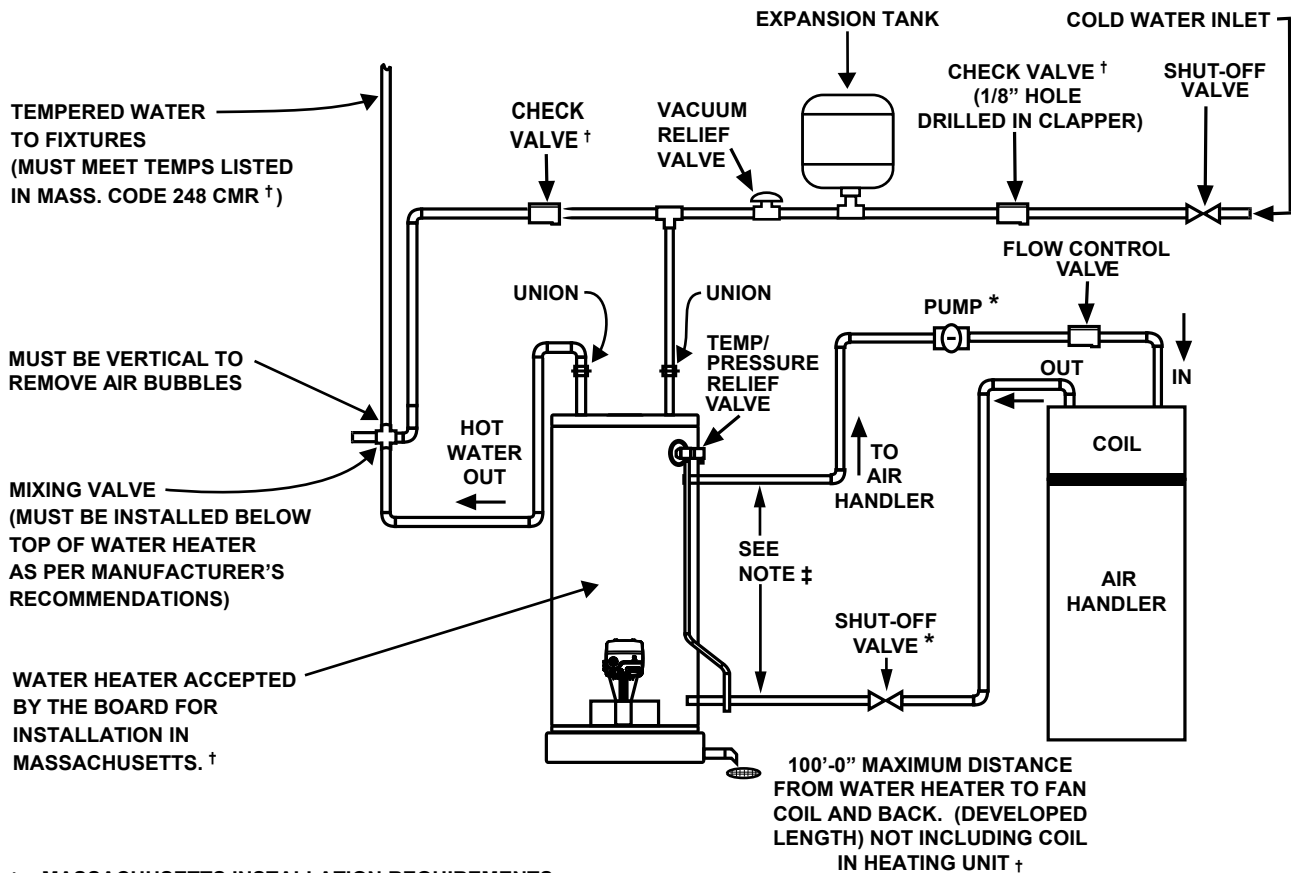

\* MASSACHUSETTS INSTALLATION REQUIREMENTS:

- 1.) CONNECT ELECTRONICALLY-CONTROLLED TIMER TO AN ALL-BRONZE PUMP. PUMP MUST ACTIVATE EVERY 6 HOURS FOR 60 SECONDS. TURN PUMP TIMER OFF BEFORE CLOSING PIPING LOOP SHUT-OFF VALVE.
- 2.) ALL WATER PIPING MUST BE INSTALLED AND INSULATED IN ACCORDANCE WITH MASSACHUSETTS CODE (248 CMR & 780 CMR).
- 3.) PIPING LOOP BETWEEN WATER HEATER AND AIR HANDLER MUST BE INSTALLED IN COMPLIANCE WITH 248 CMR.

† REQUIRED FOR MASSACHUSETTS.

‡ PIPING FROM THE TOP OF THE WATER HEATER WITH TEES IS ACCEPTABLE.

## II) SAFETY

In addition to the installation instructions found in this manual, the water heater must be installed in accordance with all local and state codes or, in the absence of such, with the latest editions of the following specifications.

### Installation Codes

“Standard for the Installation of Oil-Burning Equipment (NFPA 31)” and

“National Electrical Code. (NFPA 70)” available from:

American National Standards Institute,  
25 West 43rd Street,  
New York, NY 10036

Check your phone listings for the local authorities having jurisdiction over your installation.

**Important:** Installation and service of an oil fired water heater and burner must be performed by a qualified Oil-Burner Technician to comply with local and state codes applicable to this type of equipment. All supply equipment, installation, approvals, permits, inspections, etc. are the responsibility of the owner of this water heater. Consult your local authorities for regulations specific to your area.

### Safety Warning (Flammable Vapors)

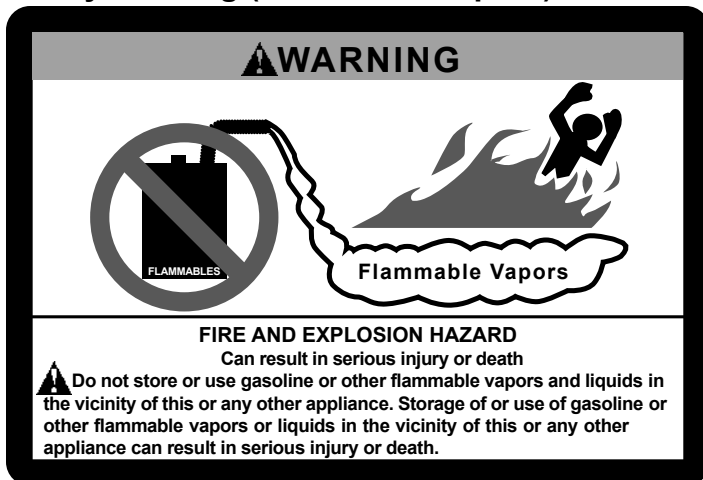

There is a risk of property damage, personal injury or death from the by-products of combustion (e.g., flue gases), in using fuel-burning appliances such as water heaters. Areas that may not be suitable for water heater installation include those where flammable liquids, gasoline, solvents, adhesives etc. are stored, or where engine-driven equipment or vehicles are stored, operated or repaired. These, and similar products, should not be stored or used near the water heater or air intake. Due to the nature of air movement, flammable vapors can be carried some distance from the point of storage. A water heater igniter or burner flame can ignite these vapors causing a flashback, fire or explosion, which may result in severe property damage, serious personal injury or death. If flammable liquids or vapors have spilled or leaked in the area of the water heater, leave the area immediately and call the fire department from a neighbor's home. Do not attempt to clean the spill until all ignition sources have been extinguished.

### Safety Warning (Scalding)

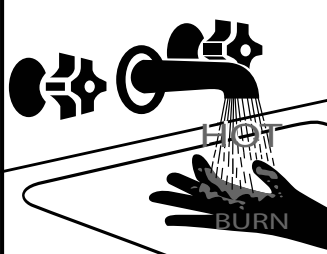

## DANGER

Water temperature over 125°F can cause severe burns instantly resulting in severe injury or death.

Children, the elderly and the disabled and are at highest risk of scald injury.

Feel water before bathing or showering.

Temperature limiting devices such as mixing valves must be installed when required by codes and to ensure safe temperatures at fixtures.

Some people are more likely to be permanently injured by hot water than others. These include the elderly, children, the infirm and the physically/mentally disabled. Table 1 (published by U.S. Government Memorandum, 1978) shows the approximate time-to-burn relationship for normal adult skin. If anyone using hot water provided by the water heater being installed fits into one of these groups or if there is a local code or state law requiring a certain water temperature at the point of use, then special precautions must be taken. Use tempering valves, also known as mixing valves, in the hot water system to reduce the risk of scalding at point-of-use such as lavatories, sinks and bathing facilities. Such precautions must be followed when this heater is operated in combination with dishwashing or space heating applications.

Water Temperature °F	Time to Produce a Serious Burn
120	More than 5 minutes
125	1½ to 2 minutes
130	About 30 seconds
135	About 10 seconds
140	Less than 5 seconds
145	Less than 3 seconds
150	About 1½ seconds
155	About 1 second

**Table 1. Scald times**

## Safety Warning (Carbon Monoxide)

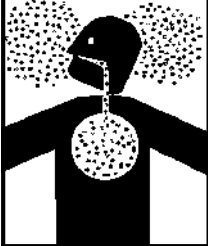
 <b>WARNING</b>	
<b>Breathing Hazard - Carbon Monoxide Gas</b>	
	<ul style="list-style-type: none"> <li>• Install vent system in accordance with codes.</li> <li>• Do not operate water heater if flood damaged.</li> <li>• Do not operate if soot buildup is present.</li> <li>• Do not place chemical vapor emitting products near water heater or vent termination hood.</li> <li>• Gas and carbon monoxide detectors are available.</li> </ul>
<p><b>Breathing carbon monoxide can cause brain damage or death. Always read and understand instruction manual.</b></p>	

As with all fuel burning equipment, this heater requires an adequate supply of air for combustion and ventilation. An insufficient air supply can result in poor combustion or the re-circulation of the flue gases. Such a condition can cause soot build-up and present a fire hazard. Flow reversal of flue gases can cause an increase of carbon monoxide inside of the dwelling that could result in serious bodily harm or death from asphyxiation.

**MAKE SURE THE FLOW OF COMBUSTION AND VENTILATION AIR IS NOT RESTRICTED.**

### Relief Valve Requirements (T&P)

All water heaters must be fitted with a proper temperature and pressure relief valve. These valves must be certified as meeting the requirements of the “**Standard For Relief Valves For Hot Water Supply Systems, ANSI Z21.22/CSA 4.4**”.

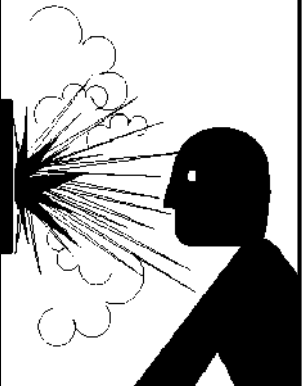
 <b>WARNING</b>	
<b>Explosion Hazard</b>	
	<ul style="list-style-type: none"> <li>• Temperature-pressure relief valve must comply with ANSI Z21.22-CSA4.4 and ASME code.</li> <li>• Properly sized temperature-pressure relief valve must be installed in opening provided.</li> <li>• Do not plug, block, or cap the discharge line.</li> <li>• Failure to follow this warning can result in excessive tank pressure, serious injury or death.</li> </ul>

If this water heater has been exposed to flooding, freezing, fire or any unusual condition, do not put it into operation until it has been inspected and approved by a qualified service technician.

THESE CONDITIONS CAN RESULT IN UNSEEN INTERNAL DAMAGE and are not subject to warranty coverage.

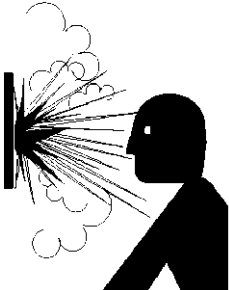
 <b>WARNING</b>	
<b>Explosion Hazard</b>	
	<ul style="list-style-type: none"> <li>• Flammable hydrogen gases may be present.</li> <li>• Keep all ignition sources away from faucet when turning on hot water.</li> </ul>

**Caution:** Hydrogen gas can be produced in a hot water system served by this heater that has not been used for a long period of time (generally two (2) weeks or more). **Hydrogen gas is extremely flammable and can ignite when exposed to a spark or flame.** To reduce the risk of injury under these conditions, it is recommended that the hot water faucet be opened for several minutes at the kitchen sink before using any electrical appliance connected to the hot water system. Use caution in opening faucets. If hydrogen is present, there will probably be an unusual sound such as air escaping through the pipe as the water begins to flow. There should be no smoking or open flame near the faucet at the time it is open.

 <b>CAUTION:</b>
<b>Possible cancer hazard by inhalation. Can cause respiratory, skin and eye irritation.</b>

This product contains fiberglass wool and ceramic fiber materials. Airborne fibers from these materials have been listed by the State of California as a possible cause of cancer through inhalation. Use special care when handling ceramic fiber (chamber lining and base insulation) materials. Ceramic fibers can be converted to chrysolites, a substance listed as a probable cause of cancer. Suppliers of fiberglass wool products recommend the following measures be taken when handling these materials:

Precautionary measures:

- Avoid breathing fiberglass dust.
- Avoid contact with skin and eyes.
- Use a National Institute for Occupational Safety and Health (NIOSH) approved dust/mist respirator.
- Wear long-sleeved, loose fitting clothing, gloves and eye protection.
- Wash work clothes separately from other clothing. Rinse washer thoroughly.

Removing the burner may generate airborne fiber concentration requiring additional protection.

First aid measures:

- Eye contact - Flush eyes with sterile water to remove foreign objects. If irritation or other symptoms persist, seek medical attention.
- Skin contact - Wash affected areas gently with soap and warm water after handling.

### Fuel Specifications

All JOHN WOOD brand water heaters are designed to burn only fuels not heavier than No.2 (furnace) oil.

#### **⚠ WARNING**

- **Do not use gasoline, crankcase drainings or any oil containing gasoline.**
- **Do not tamper with unit or controls.**
- **Never burn garbage or paper in the unit, and never leave paper or rags around it.**
- **Do not experiment with the burner.**

## III) INSTALLATION

### Unpacking the Water Heater

#### **⚠ WARNING**

##### **Excessive Weight Hazard**

**Use two or more people to move and install water heater. Failure to do so can result in back or other injury.**

**Important:** Do not remove any permanent instructions, labels, or the data label from outside of the water heater or on the inside of panels.

- Remove exterior packaging and place installation components aside.
- Inspect all parts for damage prior to installation and start-up.
- Completely read all instructions before attempting to assemble and install this product.

If you observe damage to the water heater or any of its components, **DO NOT ASSEMBLE OR INSTALL IT OR MAKE ANY ATTEMPT TO FIX THE DAMAGED PART(S)**. Contact the place of purchase for further instructions.

- After installation, dispose of packaging material in the proper manner.

### Location Requirements

The water heater must be installed indoors in an area not subject to freezing temperatures and in a vertical position on a level surface. Water heaters located in unconditioned spaces (e.g., basements etc.) may require insulation of the water piping, drain piping and venting to protect against condensation.

The water heater must be installed on a non-combustible floor, as close to the chimney as practical. Select a location as centralized within the piping system as possible. The heater should be located in an area where leakage of the tank or connections will not result in damage to the area adjacent to the water heater or to lower floors of the structure (see "IMPORTANT" notice on the following page). Before installing this water heater, consideration and planning must be given to the following details:

- Proximity to walls and other objects (see Figure 1 through Figure 3).
- Access to oil supply (see "Oil Supply").
- Routing and support of the vent piping and termination (see "Vent and Exhaust Connections").
- Position of water supply and placement of water piping and floor drain (see "Water Supply").
- How and where to obtain combustion and ventilation air supply. (see "Air Requirements").
- Connection to the electrical service. (see "Electrical Supply").

## In Earthquake Zones

**Note:** The water heater must be braced, anchored, or strapped to avoid moving during an earthquake. Contact local utilities for code requirements in your area.

<b>CAUTION</b>
<b>Property Damage Hazard</b>
<ul style="list-style-type: none"><li>• All water heaters eventually leak.</li><li>• Do not install without adequate drainage.</li></ul>

**Important:** This water heater must be installed strictly in accordance with the instructions enclosed, and local electrical, fuel and building codes. It is possible that connections to the water heater, or the water heater itself, may develop leaks. IT IS THEREFORE IMPERATIVE that the water heater be installed so that any leakage of the tank or related water piping is directed to an adequate drain in such a manner that it cannot damage the building, furniture, floor covering, adjacent areas, lower floors of the structure or other property subject to water damage. This is particularly important if the water heater is installed in a multi-story building. THE MANUFACTURER WILL NOT ASSUME ANY LIABILITY for damage caused by water leaking from the water heater, pressure relief valve, or related fittings. Select a location as centralized within the piping system as possible. In any location selected, it is recommended that a suitable drain pan be installed under the water heater. This pan must limit the water level to a MAXIMUM depth of 1 3/4 in. and have a diameter that is a minimum of 2 in. greater than the diameter of the water heater. Suitable piping shall connect the drain pan to a properly operating floor drain. When used with a fuel-fired heater, this drain pan must not restrict combustion air flow.

## Clearances and Accessibility

The minimum clearances between the heater and combustible materials are listed in Figure 1.

**Note:** These requirements are also listed on the data plate located on the front of the water heater.

A minimum of 24 in. of front clearance and 4 in. on each side should be provided for inspection and service.

	<b>⚠ WARNING</b>
	<b>Fire Hazard</b>
	For continued protection against risk of fire: <ul style="list-style-type: none"><li>• Do not install water heater on combustible floor.</li><li>• Do not operate water heater if flood damaged.</li></ul>

## Oil Supply

All aspects of oil tank location and installation, tank size, oil piping supply and burners, including any fittings, valves, filters or any fuel handling components must comply with the current edition of:

- “Standard for the Installation of Oil-Burning Equipment (NFPA 31)”.
- Local codes and regulations.
- Information provided with burner and fuel pump.

When an appliance using a float valve between the supply tank and the burner is connected to a supply tank with a capacity over 40 L (9 imperial gallons), a valve operated by a fusible link shall be installed in the fuel line adjacent to, and upstream from, the float valve.

## Burner Installation

The installation of these units shall be in accordance with the current edition of “Standard for the Installation of Oil-Burning Equipment (NFPA 31)”, local codes and the manufacturer’s instructions. The burner should be installed only by a qualified Oil-Burner Technician.

<b>⚠ WARNING</b>
<b>This installation must be performed by a qualified Oil-Burner Technician in accordance with the burner manufacturer's instructions and diagrams. The installation and maintenance of the water heater must follow all of the instructions in this manual. Improper installation can cause injury or property damage. Heater failure that is a result of improper installation, operation or maintenance is not covered by warranty.</b>



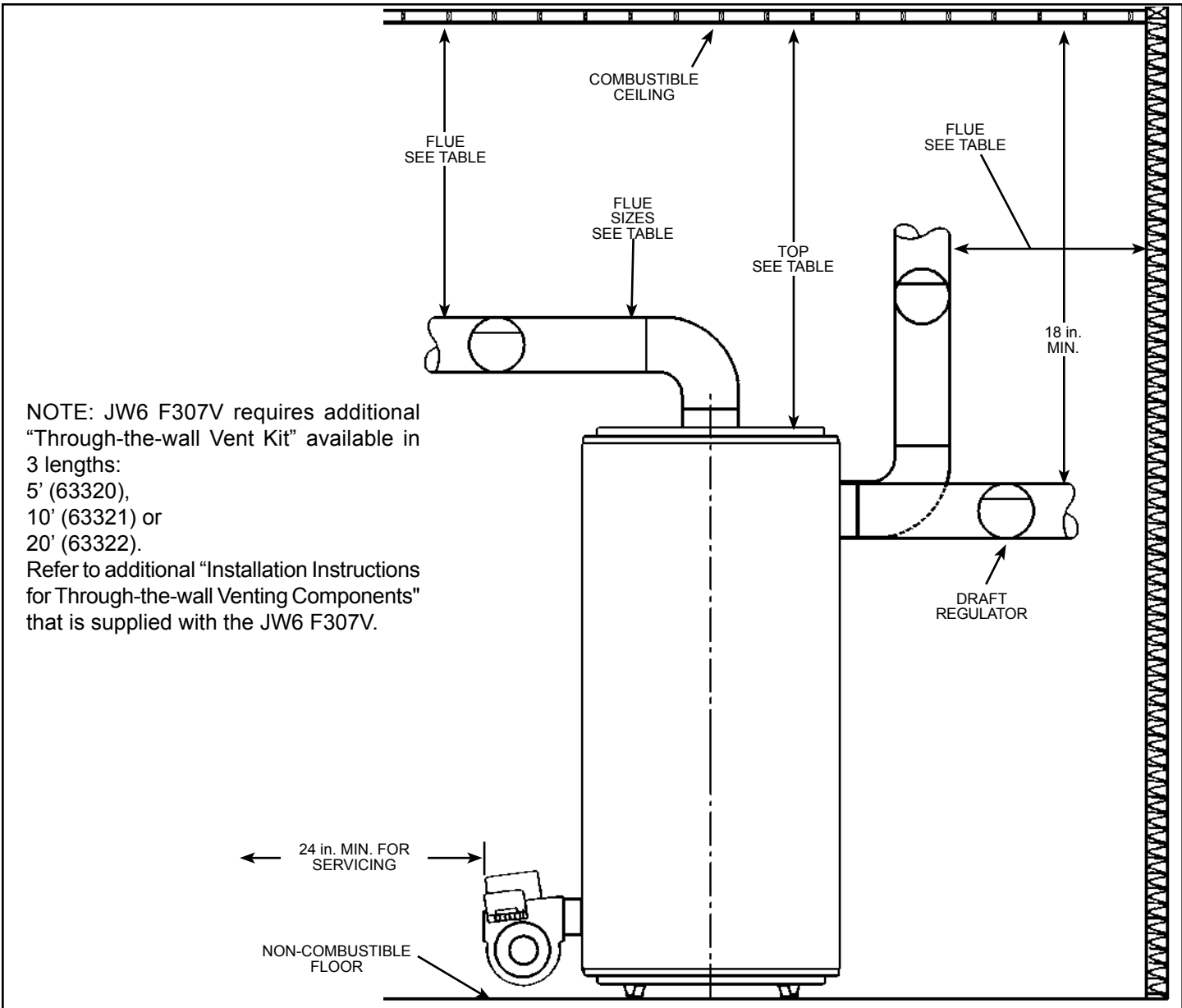

NOTE: JW6 F307V requires additional "Through-the-wall Vent Kit" available in 3 lengths: 5' (63320), 10' (63321) or 20' (63322). Refer to additional "Installation Instructions for Through-the-wall Venting Components" that is supplied with the JW6 F307V.

Model	Diam. in.	Flue location		Flue size in.	Clearance				
		Center	Rear		Front	Rear	Sides	Top	Flue
					in.	in.	in.	in.	in.
JW6 F307	20	X		6	24	2	2	18	9
JW6 F507	22	X						16	
JW F657	26	X						18	6
JW6 F307V	20	X							
JW6 317RF	24		X	7	6	6	6	14	18
JW6 517RF	28		X						
JW717	32		X						

Figure 1. Installation Clearances

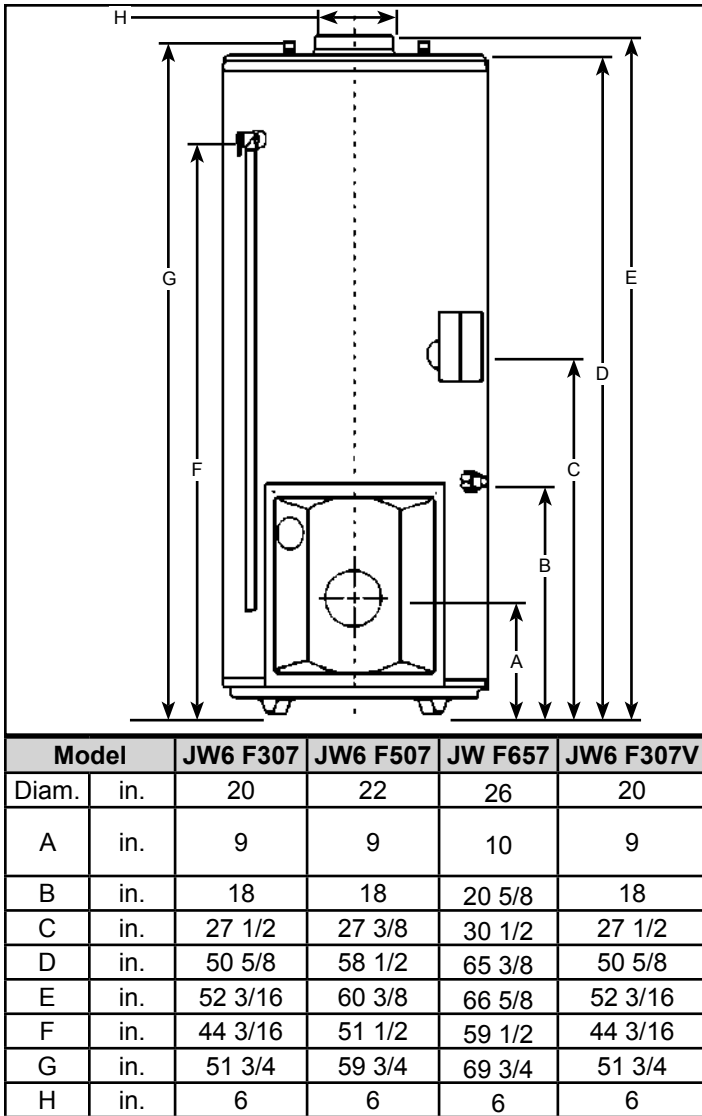

Figure 2. Installation Dimensions (Center Flue Models)

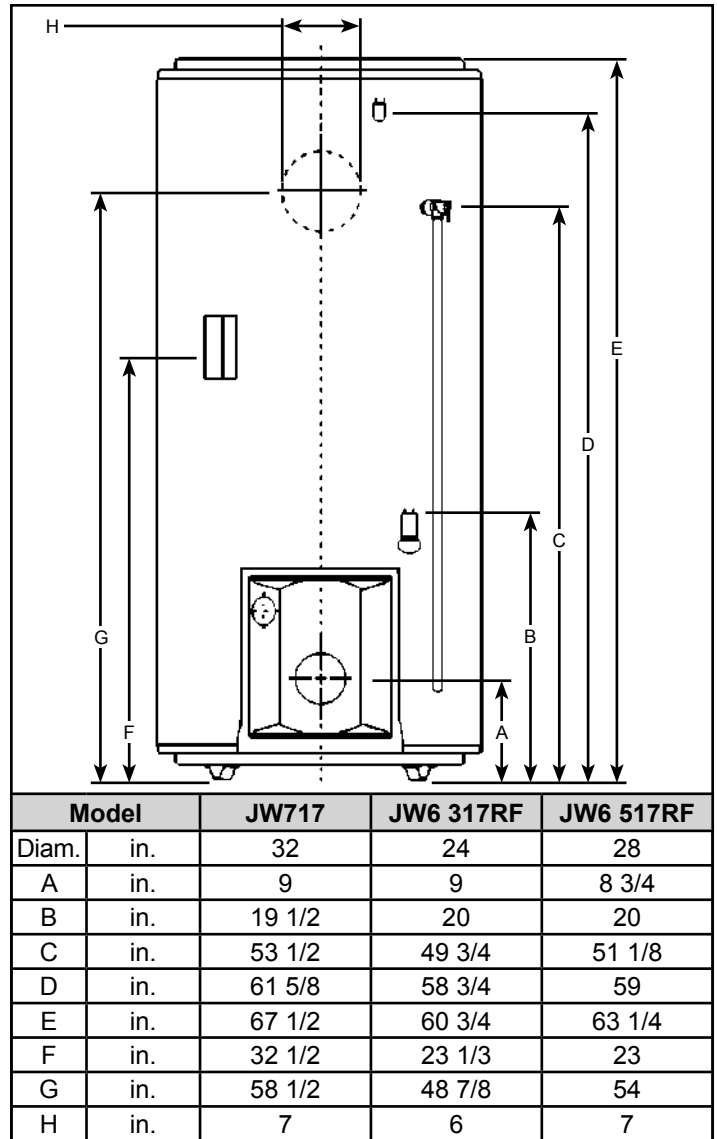

Figure 3. Installation Dimensions (Rear Flue Models)

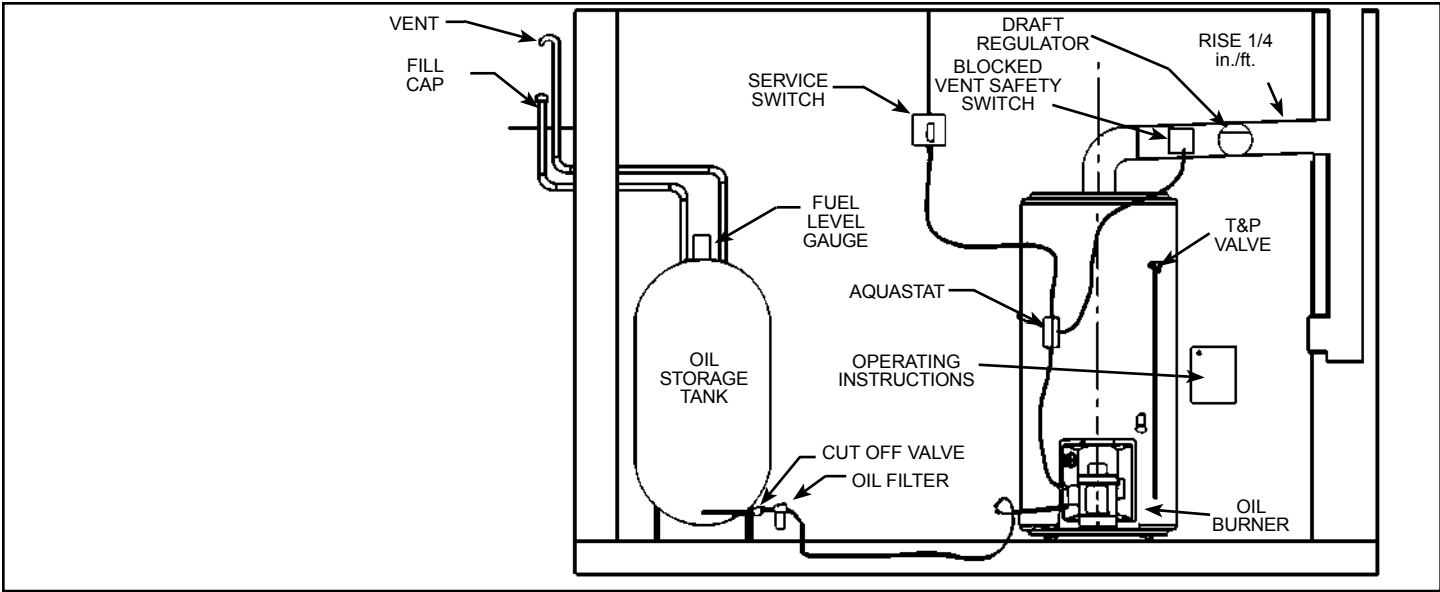

Figure 4. Typical Installation

**Air Requirements**

**WARNING**

Breathing Hazard - Carbon Monoxide Gas

- Water heater must be vented to outdoors.
- Vent must be installed by a qualified technician using the installation instructions.
- Examples of a qualified technician include: gas technicians, authorized gas company personnel, and authorized service persons.
- Failure to so do can result in death or carbon monoxide poisoning.

Breathing carbon monoxide can cause brain damage or death. Always read and understand instruction manual.

Combustion and ventilation air must be provided as per the current edition of **“Standard for the Installation of Oil-Burning Equipment (NFPA 31)”**.

An adequate supply of combustion and ventilation air is required to:

- Ensure proper combustion.
- Reduce risk of property damage, severe bodily injury or death from possible flue gas leakage and carbon monoxide emissions.

Satisfactory combustion cannot be sustained in an area that is not provided with fresh air. Fresh air contains oxygen that is necessary for proper combustion. If necessary, sufficient fresh air must be drawn in from outside of the enclosure. Lack of adequate fresh air supply may cause a poor flame.

**Important:** Air for combustion and ventilation must not come from a corrosive atmosphere. Any failure due to corrosive elements in the atmosphere is excluded from warranty coverage.

The following types of installation (not limited to the following) will require outdoor air for combustion due to chemical exposure and may reduce but not eliminate the presence of corrosive chemicals in the air:

- beauty shops
- photo processing labs
- buildings with indoor pools
- water heaters installed in laundry, hobby, or craft rooms
- water heaters installed near chemical storage areas

Combustion air must be free of acid-forming chemicals such as sulfur, fluorine, and chlorine. These elements are found in aerosol sprays, detergents, bleaches, cleaning solvents, air fresheners, paint, and varnish removers, refrigerants, and many other commercial and household products. When burned, vapors from these products form highly corrosive acid compounds. These products should not be stored or used near the water heater or air inlet.

Combustion and ventilation air requirements are determined by the location of the water heater. The water heater may be located in either an open (unconfined) area or in a confined area or small enclosure such as a closet or small room. Confined spaces are areas with less than 50 cubic feet for each 1,000 Btu/hr (4.8 cubic metres per kilowatt) [7000 cubic feet for each 1 gal./hr] of the total input for all combustion appliances.

### Unconfined Space

A water heater in an unconfined space uses indoor air for combustion and requires at least 50 cubic feet for each 1,000 Btu/hr (4.8 cubic metres per kilowatt) [7000 cubic feet for each 1 gal./hr] of the total input for all combustion appliances. The following table shows a few examples of the minimum area required for various Btu/hr inputs.

Btu/hr (kW) [GPH] Input	Minimum Square Feet with 8 Foot Ceiling	Typical Room with 8 Foot Ceiling
90,000 (26.37) [0.6]	563	20' x 28'
105,000 (30.76) [0.75]	657	20' x 33'
135,000 (39.55) [1.0]	844	28' x 30'

**Table 2. Minimum Required Area**

#### Important:

- The area must be open and be able to provide the proper air requirements to the water heater. Areas that are being used for storage or contain large objects may not be suitable for water heater installation.
- Water heaters installed in open spaces in buildings with unusually tight construction may still require outdoor air to function properly. In this situation, outside air openings should be sized the same as for a confined space.
- Modern home construction usually requires supplying outside air into the water heater area.

### Confined Space

For the correct and proper operation of this water heater, ample air must be supplied for the combustion, ventilation, and dilution of flue gases.

The size of openings (free areas) is determined by the total Btu/hr input of all combustion equipment (i.e., water heaters, furnaces, clothes dryers, etc.) and the method by which the air is provided. The Btu/hr input can be found on the water heater rating plate. Additional air can be provided by two methods:

1. All air from inside the building.
2. All air from outdoors.

#### All Air from Inside the Building

When additional air is to be provided to the confined area from additional room(s) within the building, the total volume of the room(s) must be of sufficient size to properly provide the necessary amount of fresh air to the water heater and other combustion equipment in the area. If you are unsure that the structure meets this requirement, contact your local fuel supplier or other qualified agency for a safety inspection. When indoor air is used, small enclosures and confined areas must have two permanent openings so that sufficient fresh air can be drawn from outside of the enclosure. The bottom opening must be no lower than 6 inches and no more than 18 inches above floor level. The top opening must have the same area as the bottom opening and be located as close to the ceiling as possible (see Figure 5).

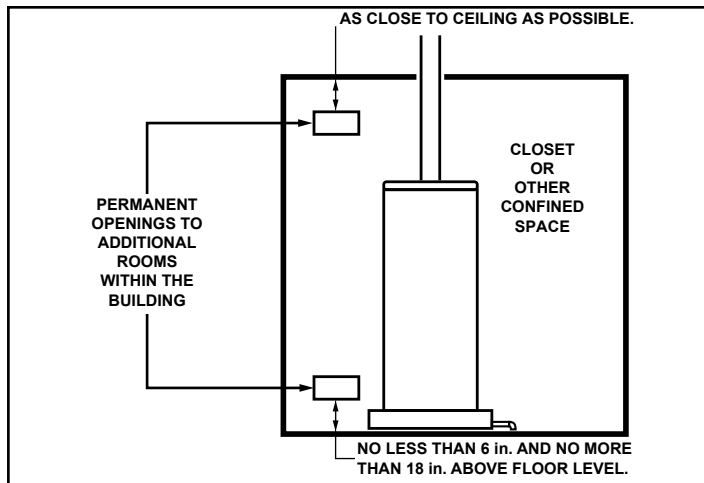

**Figure 5. Location Of Openings**

Each of the two openings shall have a minimum free area of 1 in.<sup>2</sup> per 1,000 Btu/hr (22.2cm<sup>2</sup> per kW) [140 in.<sup>2</sup> per gal/hr] of the total input rating of all combustion equipment in the confined area, but not less than 100 square inches (645 cm<sup>2</sup>) (see Figure 6).

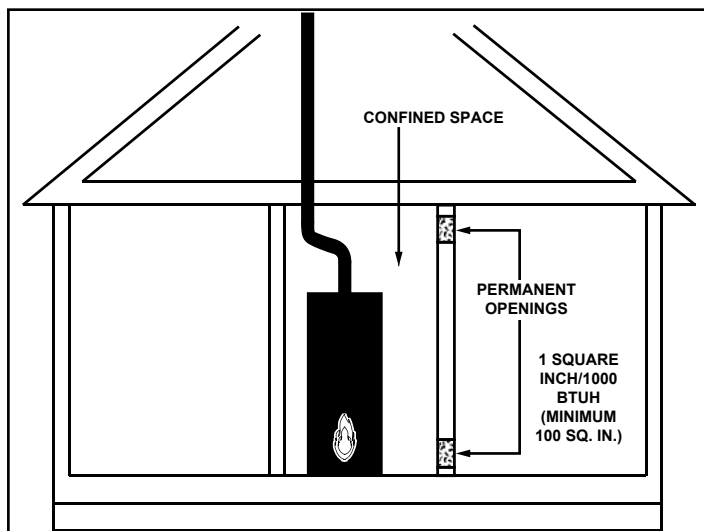
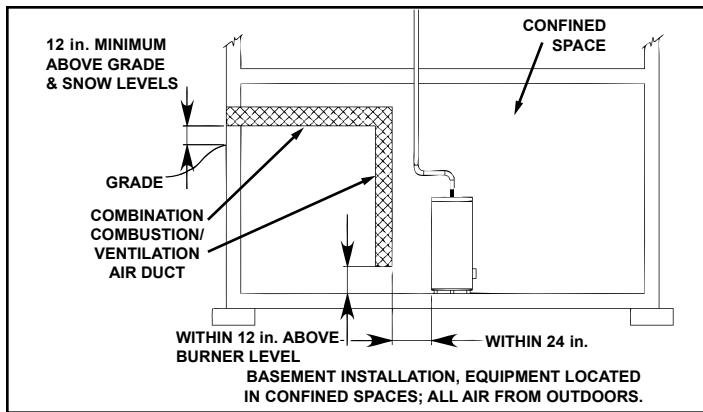

**Figure 6. Size Of Openings**

For specific ventilation and combustion air requirements, consult the current edition of “**Standard for the Installation of Oil-Burning Equipment (NFPA 31)**” and the local codes of your area.

#### All Air from Outdoors

Outdoor fresh air can be provided to a confined area either directly or by the use of ducts. The fresh air can be taken from the outdoors or from crawl or attic spaces that freely communicate with the outdoors. Attic or crawl spaces cannot be closed and must be properly ventilated to the outside. Ductwork must be of the same cross-sectional area as the free area of the opening to which they connect. The minimum dimension of rectangular air ducts cannot be less than 3 inches. In addition, the duct must terminate within 12 inches above, and within 24 inches horizontally from, the burner level of the appliance having the largest input (see Figure 7).



**Figure 7. Basement Installation**

An opening may be used in lieu of a duct to provide the outside air supply. It, too, must be located within 12 inches above, and within 24 inches horizontally from, the burner level of the appliance having the largest input. However, it must be located at least 12 inches above the outside grade level and be clear of snow levels. In addition, it must be equipped with a means to prevent the direct entry of rain and wind without reducing the required free area of the opening.

The size of openings is determined by the method in which the air is to be provided. For specific ventilation and combustion air requirements, consult the current edition of “**Standard for the Installation of Oil-Burning Equipment (NFPA 31)**” and the local codes of your area.

### Louvers and Grilles

In calculating free area for ventilation and combustion air supply openings, consideration must be given to the blocking effect of protection louvers, grilles, and screens. These devices can reduce airflow, which in turn may require larger openings to achieve the required minimum free area. Screens must not be smaller than 1/4 inch mesh. If the free area through a particular design of louver or grille is known, it should be used in calculating the specified free area of the opening. If the design and free area are not known, it can be assumed that most wood louvers will allow 20 - 25% of free area while metal louvers and grilles will allow 60 - 75% of free area.

Louvers and grilles must be interconnected with the equipment so that they are opened automatically during equipment operation. Also, keep louvers and grilles clean and free of debris or other obstructions. Do not use manually adjustable louvers.

Consult the local codes of your area for specific ventilation and combustion air requirements.

### Vent and Exhaust Connections

The vent and exhaust connections must comply with the requirements of the current edition of “**Standard for the Installation of Oil-Burning Equipment (NFPA 31)**”.

### Vent Pipe System

This water heater uses a non-direct, single-pipe vent system to remove exhaust gases created by the burning of fossil fuels. Air for combustion is taken from the immediate water heater location or is ducted in from the outside (see "Air Requirements" and "Vent and Exhaust Connections")

This water heater must be properly vented for the removal of exhaust gases to the outside atmosphere. Correct installation of the vent pipe system is mandatory for the proper and efficient operation of this water heater and is an important factor in the life of the unit.

The vent pipe must be installed according to the current edition of “**Standard for the Installation of Oil-Burning Equipment (NFPA 31)**” and all local/state codes.

The vent pipe installation must not be obstructed so as to prevent the removal of exhaust gases to the outside atmosphere.

### Important:

- The use of vent dampers is not recommended by the manufacturer of this water heater. Although some vent dampers are certified by CSA International, this certification applies to the vent damper device only and does not mean they are certified for use on this water heater.
- Certified (listed) carbon monoxide (CO) detectors are recommended in all applications and should be installed using the manufacturer’s instructions and local codes, rules, or regulations.
- The venting system must be installed by a qualified technician.

### General Chimney Requirements

All oil-heaters shall be connected to a chimney having sufficient draft at all times to ensure for safe and proper operation, except those heaters that are specifically certified for other means of venting (JW6 F307V - Direct vent models). For a burner designed for natural draft connect the vent to a vertical chimney. Insufficient draft can cause flue gas leakage and carbon monoxide emissions, which can lead to severe bodily injury or death. Use vent material approved by local codes for oil-fired burners. In the absence of such codes, refer to the current edition of

- “**Standard for the Installation of Oil-Burning Equipment (NFPA 31)**”.
- “**Standard for Chimneys, Fireplaces, Vents, and Solid Fuel-Burning Appliances (NFPA 211)**”.

Inspect existing chimney before installing the water heater. Failure to do any of the following can result in serious property damage, severe bodily injury or death:

- Clean the chimney, including removal of blockage.
- Repair or replace damaged pipe or liner.
- Repair mortar and joints.

To prevent downdrafts, extend the chimney at least 3 ft. above the highest point where it passes through the roof and 24 in. higher than any portion of the building within 10 ft..

## Flue Pipe

**Note:** Type "L" vent material is generally considered to be not suitable for this application. Flue temperatures may exceed 572°F. Use flue piping approved for this installation.

Long horizontal flue pipes, excessive number of tees and elbows or other obstructions restrict flue gas flow, and can result in the possibility of condensation, flue gas leakage and carbon monoxide emissions. These conditions can lead to serious property damage, severe bodily injury or death. The flue pipe should be the same size as the breech connection on the appliance. The sizes generally are 6 in. for burners rated less than 1.00 GPH and 7 in. for burners rated 1.00 to 1.50 GPH. The flue pipe should be as short as possible and installed so that it has a continuous rise of 1/4 in./ft. of horizontal length from the breech connection on the appliance to the chimney. Elbows should be minimized and the sections of pipe and fittings should be joined with sheet metal screws and straps. Routing should be made in such a way as to avoid sharp turns or unduly long runs. It is recommended that the heater be piped to its own individual flue. Where there is only one flue for both furnace and water heater, various methods are practiced in which the water heater flue enters the chimney above the main smoke pipe. Also, a "Y" fitting is frequently used to combine the heater and furnace flues, prior to entering the chimney connection (see Figure 4, check with local authorities having jurisdiction). Obtain a gas-tight seal to prevent possible flue gas leakage and carbon monoxide emissions, which can lead to severe bodily injury or death.

## Draft Regulator

This device is used on conventional chimney venting only. It automatically maintains a constant negative pressure in the chimney to obtain maximum efficiency. If the chimney does not develop sufficient draft, the draft control cannot function properly. The heater must be equipped with an approved draft regulator of adequate size. Ensure the draft regulator diameter is at least as large as the flue pipe diameter. Follow manufacturers recommended instructions for installation. It must be installed in the flue pipe before it enters the chimney and after the Blocked Vent Safety Switch. Set the draft regulator at -0.03 in. w.c. (-7.46Pa), as measured in the flue (between the heater and the draft regulator). Recommended over-fire draft is -0.02 in. w.c. (-4.97Pa).

## Chimney

Be sure that the chimney is sufficiently high and large enough to meet the specifications of the burner unit installed. Check that there is sufficient draft for the proper burning of oil. At least -0.015 in. w.c. (-3.73Pa) of over-fire draft is recommended.

## Blocked Vent Safety Switch

Oil-fired water heaters must be fitted with the blocked vent safety switch supplied with your heater. The installation procedure is given below. For further details and information refer to the instruction sheet supplied with the switch (Not required for JW6 F307V).

## Installation

1. Pierce a 5/8 in. dia. hole into the flue pipe 12 to 18 in. from the breech connection of the water heater. Remove one of the securing nuts from the pipe of the safety switch. Tighten the other securing nut onto the pipe as far as possible.
2. Insert the threaded pipe end into the pierced hole, then install the securing nut, which was removed in step 1, and tighten securely.

**Caution:** Turn "OFF" the electrical supply to the water heater when wiring safety switch.

3. Wire the safety switch in series with L1 of the electrical supply. Install and route wiring in an accordance with "**National Electrical Code. (NFPA 70)**" and any applicable local codes.

**Caution:** If for any reason the system has shut down during operation, the cause of the system failure should be investigated and corrected before resetting the safety switch and re-starting the system.

## Power Venting

Models JW6 F307, JW6 F507 and JW F657 may be power vented with a Field SWGII 4HD Power Venter. The following control kits may be used with the SWGII 4HD:

CK 61 Electronic Post Purge.

CK 62 Thermally Activated Post Purge.

## Installation Of Power Venter

The current edition of “**Standard for the Installation of Oil-Burning Equipment (NFPA 31)**”, local codes and the manufacturer's instructions should be adhered to in all installations of the water heaters and power venters. A draft regulator must be used in conjunction with the installation of the power venter (see "Draft Regulator"). Consult the applicable codes to calculate the equivalent length of pipe for each fitting in the vent system. Add this (equivalent) length to the length of the straight runs of pipe to determine the total equivalent vent pipe length.

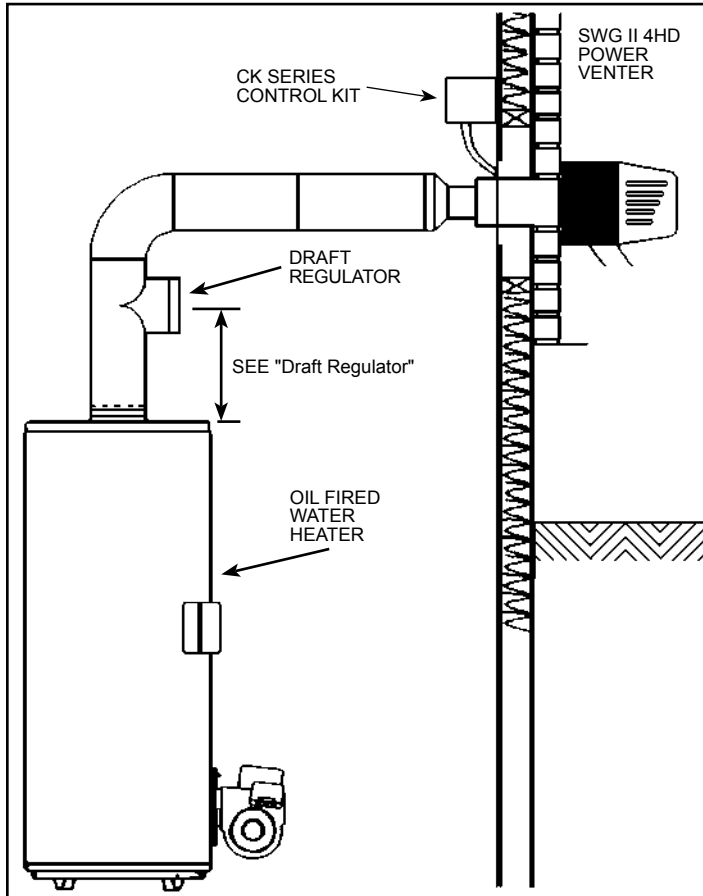

Figure 8. Power Venting

## Water Supply

This appliance has been design certified as complying with CSA Standard for water heaters and is considered suitable for Water (Potable) Heating and Space Heating.

The water heater should not be subjected to excessive water pressure fluctuations and should not be subjected to an operating pressure greater than 80 psi. If this occurs, a pressure-reducing valve with a bypass should be installed in the cold-water inlet line. This should be placed on the supply to the entire house in order to maintain equal hot and cold water pressure.

## CAUTION

### Property Damage Hazard

- Avoid water heater damage.
- Install thermal expansion tank if necessary.
- Do not apply heat to cold-water inlet or hot-water outlet.
- Contact qualified installer or service agency.

## Piping Installation

Piping, fittings, and valves should be installed according to the applicable installation drawing (Figure 9 and Figure 10). A pressure-reducing valve and/or an expansion tank may be required for installations where the water pressure is high. The pressure-reducing valve should be located on the supply to the entire house in order to maintain equal hot and cold water pressure.

### Important:

- Do not apply heat to the water fittings on the heater as they may contain nonmetallic parts. If solder connections are used, solder the pipe to an adaptor before attaching the adaptor to the hot and cold water fittings.
  - Some models may contain energy saving heat traps to prevent the circulation of hot water within the pipes. Do not remove the inserts within the heat traps.
  - Always use a proper grade of joint compound and be certain that all fittings are drawn up tight.
1. Install the water piping and fittings as shown in Figure 9 or Figure 10. Connect the cold water supply to the unmarked fitting (3/4" NPT). Connect the hot water supply to the fitting (3/4" NPT) marked "HOT" (or "H").
  2. The installation of unions in both the hot and cold water supply lines is recommended.
  3. The manufacturer of this water heater recommends installing a tempering valve in the domestic hot water line. These valves reduce the point-of-use water temperature by mixing cold and hot water. Contact a licensed plumber or the local plumbing authority.

**Note:** For water heaters intended for household use, a thermostatically controlled tempering valve meeting the requirements of CSA B125 or ASSE 1016 or 1017 should be used to temper the domestic hot water supply to fixtures to 120°F.

4. If installing the water heater in a closed water system, install an expansion tank in the cold water line as specified under "Closed System/Thermal Expansion".

5. Install a shut-off valve in the cold water inlet line. It should be located close to the water heater and be easily accessible. The owner/operator must be shown the location of this valve and be given instructions on how to use it to shut off the water to the heater.

**Note:** Rear and Combination flue heaters are equipped with a combination cold water inlet/drain valve.

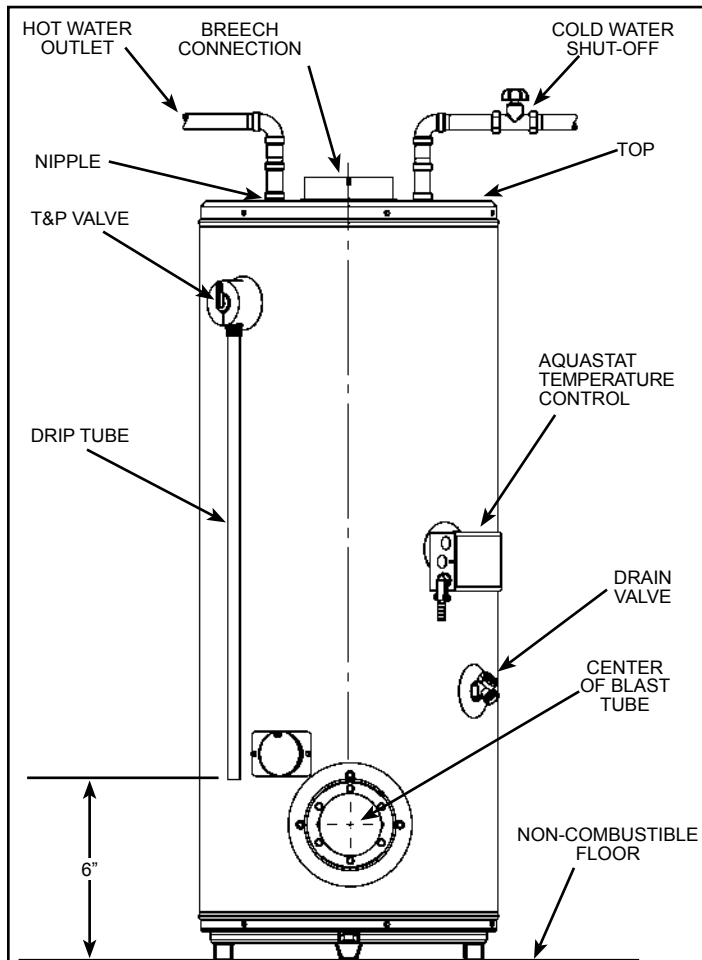

**Figure 9. Plumbing Connections (Center Flue)**

Please note the following:

DO NOT install this water heater with iron piping. The system should be installed only with piping that is suitable for potable (drinkable) water such as copper, or PEX.

DO NOT use PVC water piping.

DO NOT use any pumps, valves, or fittings that are not compatible with potable water.

DO NOT use valves that may cause excessive restriction to water flow. Use full flow ball or gate valves only.

DO NOT use any lead based solder in potable water lines. Use appropriate tin-antimony or other equivalent material.

DO NOT tamper with the aquastat, burner or temperature and pressure relief valve. Tampering voids all warranties. Only qualified service technicians should service these components.

DO NOT use with piping that has been treated with chromates, boiler seal, or other chemicals.

DO NOT add any chemicals to the system piping which will contaminate the potable water supply.

This unit must NEVER be connected to any existing heating system or component(s) previously used with a non-potable water heating appliance. All models are suitable for combination potable water and space heating applications.

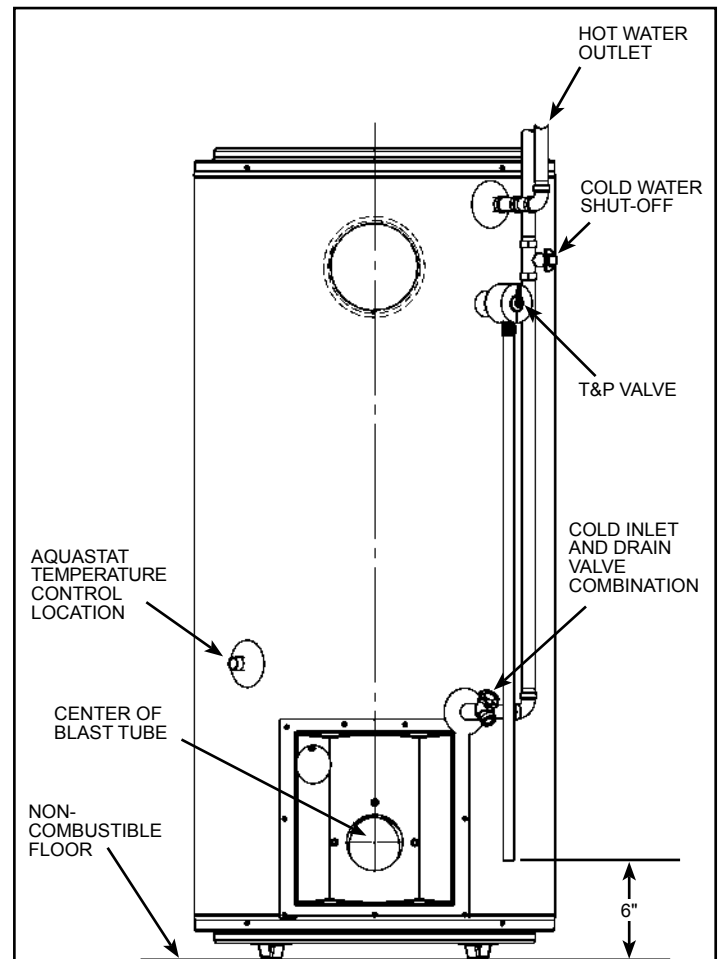

**Figure 10. Plumbing Connections (Center/Rear Flue)**

### Mixing Valves

Water heaters are intended to produce hot water. Water heated to a temperature which satisfies space heating, clothes washing, dish washing, and other sanitizing needs can scald and cause permanent injury upon contact. Short repeated heating cycles caused by small hot-water uses can cause temperatures at the point of use to exceed the water heater's temperature setting by up to 20F°.

Some people are more likely to be permanently injured by hot water than others. These include the elderly, children, the infirm and the physically/mentally disabled. Table 3 shows the approximate time-to-burn relationship for normal adult skin. National plumbing code requirements limit the temperatures of certain fixtures in the home. Local codes may have additional requirements. In addition to these requirements, if anyone using hot water in your home fits into one of these groups, then you must take special precautions. In addition to using the lowest possible temperature setting that satisfies your hot water needs, a means such as a Mixing Valve, should be used at the hot water taps used by these people or at the water heater. Mixing valves are available at plumbing supply or hardware stores. Consult a Qualified Installer or Service Agency. Follow mixing valve manufacturer's instructions for



installation of the valves (see Figure 11). Before changing the factory setting on the thermostat, read the "Water Temperature Regulation" section in this manual.

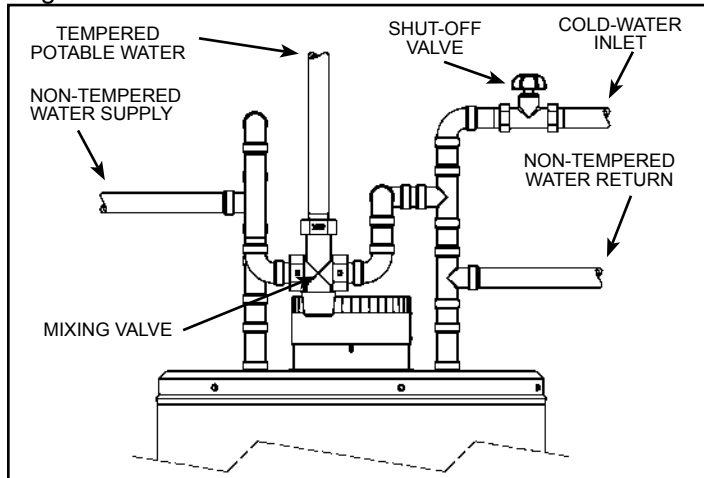

**Figure 11. Suggested Plumbing Connections For Mixing Valve Installation**

**Closed System/Thermal Expansion**

Water supply systems may, because of code requirements or such conditions as high line pressure, among others, have installed devices such as pressure reducing valves, check valves, and back flow preventers. Devices such as these cause the water system to be a closed system. As water is heated, it expands (thermal expansion). In a closed system the volume of water will grow when it is heated. As the volume of water grows there will be a corresponding increase in water pressure due to thermal expansion. Thermal expansion can cause premature tank failure (leakage). This type of failure is not covered under the limited warranty. Thermal expansion can also cause intermittent Temperature-Pressure Relief Valve operation: water discharged from the valve due to excessive pressure buildup. This condition is not covered under the limited warranty. The Temperature-Pressure Relief Valve is not intended for the constant relief of thermal expansion. A properly sized thermal expansion tank must be installed on all closed systems to control the harmful effects of thermal expansion. Contact a local plumbing service agency to have a thermal expansion tank installed.

**Important:** Do not plug or remove the temperature and pressure relief valve.

**Temperature And Pressure (T&P) Relief Valve**

<b>WARNING</b>	
	<b>Explosion Hazard</b>
	<ul style="list-style-type: none"> <li>Temperature-pressure relief valve must comply with ANSI Z21.22-CSA4.4 and ASME code.</li> <li>Properly sized temperature-pressure relief valve must be installed in opening provided.</li> <li>Do not plug, block, or cap the discharge line.</li> <li>Failure to follow this warning can result in excessive tank pressure, serious injury or death.</li> </ul>

For protection against excessive pressures and temperatures, a temperature and pressure relief valve must be installed in the opening marked "T&P RELIEF VALVE". This valve must be design certified by a nationally recognized testing laboratory that maintains periodic inspection of the production of listed equipment or materials as meeting the requirements of the "**Standard For Relief Valves For Hot Water Supply Systems**", **ANSI Z21.22/CSA 4.4**". The function of the temperature and pressure relief valve is to discharge water in large quantities in the event of excessive temperature or pressure developing in the water heater. The valve's relief pressure must not exceed the working pressure of the water heater as stated on the data plate.

A T&P valve is either installed or supplied loose with this water heater.

**Important:** Only a new temperature and pressure relief valve should be used with your water heater. Do not use an old or existing valve as it may be damaged or not adequate for the working pressure of the new water heater. Do not place any valve between the relief valve and the tank.

**The Temperature And Pressure Relief Valve:**

- Must not be in contact with any electrical part.
- Must be connected to an adequate discharge line.
- Must not be rated higher than the working pressure shown on the data plate of the water heater.

## The Discharge Line/Driptide:

<b>CAUTION</b>	
<b>Water Damage Hazard</b>	
<ul style="list-style-type: none"><li>• Temperature-pressure relief valve discharge pipe must terminate at an adequate drain.</li></ul>	

- Must not be smaller than the pipe size of the relief valve or have any reducing coupling installed in the discharge line.
- Must not be capped, blocked, plugged or contain any valve between the relief valve and the end of the discharge line.
- Must terminate a maximum of 6 in. above the floor.
- Must be capable of withstanding 250°F without distortion.
- Must be installed to allow complete drainage of both the valve and discharge line.

Failure to install and maintain a new, properly listed temperature and pressure relief valve will release the manufacturer from any claims which may result from excessive temperature or water pressure.

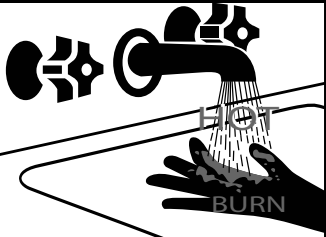
<b>⚠ DANGER</b>	
	<ul style="list-style-type: none"><li>• Burn hazard.</li><li>• Hot water discharge.</li><li>• Keep clear of temperature-pressure relief valve discharge.</li></ul>

### Temperature-Pressure Relief Valve And Pipe Insulation

On some water heater models, the T&P valve will be installed and covered by insulation to minimize heat loss. The insulation has a hole on the bottom side to accommodate the valve outlet and allow for the piping connection. Do not restrict the outlet opening of the T&P valve. If supplied loose, the T&P valve must be installed in the location indicated on the water heater and covered with insulation (supplied) as follows:

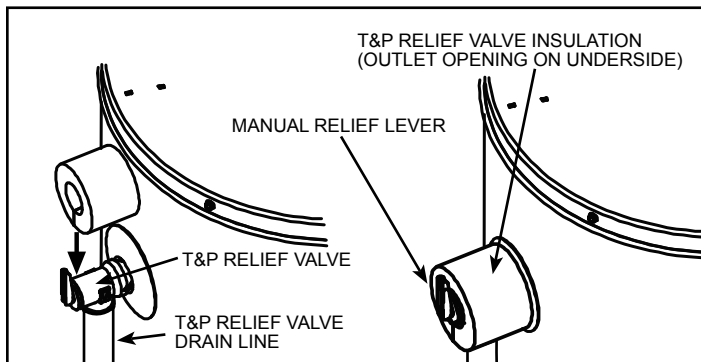

Figure 12. T&P Valve Insulation

Locate the temperature and pressure relief valve on the water heater (also known as a T&P relief valve) (see Figure 12).

1. Locate the slit running the length of the T&P relief valve insulation.

2. Spread the slit open and fit the insulation over the T&P relief valve (see Figure 12). Apply gentle pressure to the insulation to ensure that it is fully seated on the T&P Relief Valve. Once seated, secure the insulation with duct tape, electrical tape, or equivalent.

**Important:** The insulation and tape must not block the discharge opening or hinder access to the manual relief lever (Figure 12). Ensure a discharge pipe is installed into the T&P valve discharge opening per the instructions in this manual.

### Vacuum Relief Valves

A vacuum relief valve, installed in the cold water supply line above the top of the water heater, shall protect the water heater against siphoning (loss of water due to loss of supply pressure). Where heating equipment has a bottom supply, the cold water supply piping shall be carried above the top of the heater before being routed to the supply connection and have a vacuum relief valve installed in it at a level above the top of the storage tank. The vacuum relief valve shall be in compliance with the latest edition of “**Standard For Relief Valves For Hot Water Supply Systems, ANSI Z21.22/CSA 4.4**”.

### Installation Of The Aquastat (Temperature Control)

This heater operates automatically under the control of the aquastat, which responds to the demand of hot water. The aquastat, thermowell, and wiring are included in the carton containing the burner. The installation of the aquastat should proceed as follows:

1. Locate the thermowell opening in the front of the heater.
2. Remove shipping nipple (if present).
3. Apply a good grade of pipe joint compound to the threads on the well.
4. Install the thermowell in the tank opening, tighten firmly to ensure there are no leaks.
5. Insert the sensing bulb of the aquastat into the well and secure the aquastat to the well using the screw(s) provided.

### Electrical Supply

General wiring requirements:

Electric shock hazard. Can cause severe personal injury or death if power source, including service switch on heater, is not disconnected before installing or servicing. Installations must comply with the latest editions of these codes:

- “**National Electrical Code. (NFPA 70)**”.
- Any additional local, state or national codes.

Wire the control to the burner as shown in the wiring diagrams supplied with the burner.

If original wire supplied with the heater is to be replaced, TYPE 105°C wire or equivalent must be used. Supply wiring to heater and additional control wiring must be 14 GA. or heavier. Provide an electrical ground as required by codes.

## Filling The Water Heater

# CAUTION

### Property Damage Hazard

- Avoid water heater damage.
- Fill tank with water before operating.

Do not insert the power cord into the electrical receptacle until all the following steps have been completed.

1. Make sure the drain valve is closed.
2. Open all hot water faucets served by the system to allow air to escape from the tank.
3. Open the cold water inlet valve.

**Note:** When filling, avoid water leakage. Do not allow the insulation of the water heater to get wet as water can reduce the effectiveness of the insulation.

4. When an uninterrupted stream of water, without apparent air bubbles, flows from the open hot water faucets, the tank is full.
5. Close the hot water faucets and check the system for leaks. Repair as required and retest.
6. Connect a hose to the drain valve and route to a suitable drain.
7. Open the drain valve and let water run to flush out any foreign matter that may have entered the system. Continue flushing until clean water flows.
8. Close the drain valve, disconnect the hose, ensure the drain valve does not drip and re-fill the tank.

## Installation Checklist

- Have the safety precautions described in the manual been implemented?
- Does the oil piping conform to the recommendations of your Oil Supply Company?
- Has the oil piping been tested for leaks?
- Is the clearance between the water heater and combustible construction as per specifications?
- Is the water piping correctly connected? Are you certain that there are no leaks?
- Is the water heater filled with water?
- Is the cold water supply valve open?
- Is the flue pipe installed properly and are the vertical and horizontal runs properly supported?
- Is the draft regulator intake opening unobstructed?
- Is the T&P valve installed? Are the drain pipe (if installed) and T&P valve unobstructed?
- Is a drain pan installed (if required) with a proper overflow pipe, directed to a drain?
- Have you taken steps to prevent water damage in case of leaks?
- Does the area around the water heater have adequate ventilation?
- Air moving device does not create negative pressure?
- Flammable vapors and materials are not placed in the proximity of the water heater?

If the answer to all the above is "Yes", proceed with the "Startup" instructions.

## IV) OPERATION

### Startup

#### **CAUTION:**

**Read before proceeding. If you do not follow these instructions exactly, a fire or explosion may result, causing property damage, personal injury or loss of life.**

DO NOT ATTEMPT TO START BURNER IF ANY OF THE FOLLOWING CONDITIONS EXIST:

1. Excess oil has accumulated.
2. The unit is full of vapors.
3. The combustion chamber is hot.

**Note:** Refer to the instruction manual supplied with the burner for installation, start up and adjustment.

After the installation is finished and the installation checklist completed, proceed as follows:

1. Set the draft regulator for full draft.
2. Turn on oil at the tank. Adjust the air band on the burner according to the instructions provided by the burner manufacturer.

3. Close the inspection cover.
4. Set electric switch to "ON" position. The burner should start.
5. Make the air adjustment and take the necessary combustion test readings as specified by the burner manufacturer. The sealing screw under the inspection cover can be removed to view the flame (if applicable).
6. Re-install the sealing screw and close the inspection cover (307, 307V and 507 only).

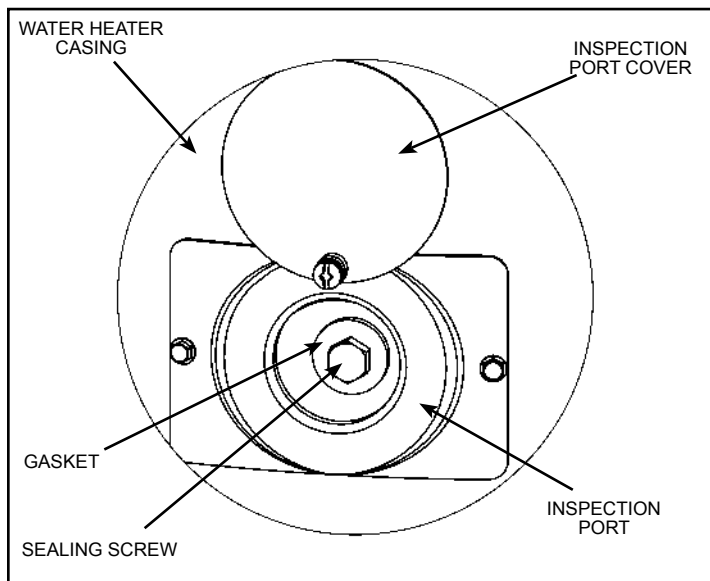

Figure 13. Inspection Port (307, 307V, 507)

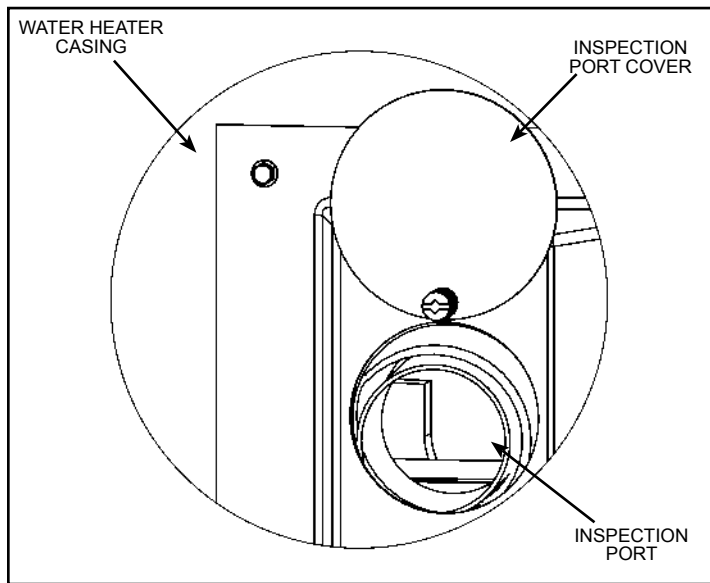

Figure 14. Inspection Port (317, 517, 657, 717)

## Water Temperature Regulation

⚠
DANGER

Water temperature over 125°F can cause severe burns instantly resulting in severe injury or death.

Children, the elderly and the disabled and are at highest risk of scald injury.

Feel water before bathing or showering.

Temperature limiting devices such as mixing valves must be installed when required by codes and to ensure safe temperatures at fixtures.

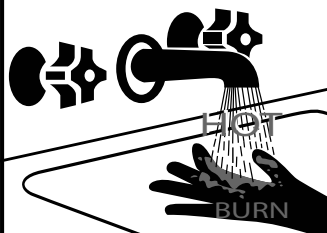

Once installed, the operation will be completely automatic. The thermostat (aquastat) on the water heater is adjustable and will maintain water at the desired temperature. Set the tank thermostat as low as possible to provide an adequate supply of hot water. This will conserve oil and extend the life of the tank.

Water Temperature °F	Time to Produce a Serious Burn
120	More than 5 minutes
125	1½ to 2 minutes
130	About 30 seconds
135	About 10 seconds
140	Less than 5 seconds
145	Less than 3 seconds
150	About 1½ seconds
155	About 1 second

Table 3. Scald Times

Refer to instructions provided with the aquastat to adjust the temperature setting.

**⚠ WARNING**

Models 307, 307V and 507 require a sealed combustion chamber during operation. Make sure the inspection port is sealed with the sealing screw, cover, and gasket.

## Water Heater Operation

### **WARNING**

**Keep the area around the heater clear and unobstructed.**

#### Stacking

Stacking occurs when a series of short draws of hot water (3 US gallons or less) are taken from the water heater tank. This causes increased cycling of the burner and can result in increased water temperatures at the hot water outlet. A tempering device is recommended in the hot water supply line to reduce the risk of scald injury.

#### Water Heater Sounds

During the normal operation of the water heater, sounds or noises may be heard. These noises are common and may result from the following:

1. Normal expansion and contraction of metal parts during periods of heat-up and cool-down.
2. Condensation causes sizzling and popping within the burner area and should be considered normal.
3. Sediment buildup in the tank bottom will create varying amounts of noise and may cause premature tank failure. Drain and flush the tank as directed under "Draining And Flushing".

#### Smoke/Odor

The water heater may give off a small amount of smoke and odor during the initial start-up of the unit. This is due to the burning off of oil from metal parts of a new unit and will disappear after a few minutes of operation.

#### Anode Rod/Water Odor

Each water heater contains at least one anode rod, which will slowly deplete while protecting the glass-lined tank from corrosion and prolonging the life of the water heater. Once the anode is depleted, the tank will start to corrode, eventually developing a leak. Certain water conditions will cause a reaction between this rod and the water. The most common complaint associated with the anode rod is a "rotten egg smell" produced from the presence of hydrogen sulfide gas dissolved in the water. Do not remove this rod permanently as it will void any warranties, stated or implied. A special anode can be ordered if water odor or discoloration occurs. This rod may reduce, if not eliminate, water odor problems. The water supply system may require special filtration equipment from water conditioning company to successfully eliminate all water odor problems. Artificially softened water is exceedingly corrosive because the process substitutes sodium ions for magnesium and calcium ions. The use of a water softener may decrease the life of the water heater tank. The anode rod should be inspected every year. If the rod is more than 50% depleted, the anode rod should be replaced.

## V) MAINTENANCE

Do not attempt to repair your water heater. Call a qualified Oil-Burner Technician for service. Turn "OFF" the electric power whenever the water supply is shut off. Before calling for service, check that:

1. The heater is properly filled.
2. The electrical supply has not been interrupted.

#### Professional Maintenance

Except for external appearance and area tidiness, the following steps should be performed only by a qualified Oil-Burner Technician.

1. Lift out the flue baffle to clean the flue. (On rear and combination flue heaters, the top cover, insulation and flue top cover must be removed.)
2. Insert a flue brush down the flue passage way(s) to remove soot and dirt. Soot or carbon that falls into the combustion chamber will burn up within a very short time.
3. In normal use, there should be no large accumulation of soot in the combustion chamber. If there is, remove the burner and carefully brush or vacuum the combustion chamber.

**Note:** The combustion chamber is not a replaceable component.

Have your oil filter cleaned or replaced by a qualified technician at an interval recommended by your oil supplier.

#### Flue Pipes

Once a year, inspect the flue pipe leading from the heater to the chimney. If corrosion is evident, or discoloration at the joints can be seen, replace the flue pipes. This should be done by a qualified Oil-Burner Technician. Flue pipes must be replaced by the same size flue pipe as the flue collar (breach connection) at the heater.

## Combustion Tests

Burner adjustments:

Final burner adjustments must be made using combustion test equipment to assure proper operation.

1. Fill heater with water. Do not fire heater without water or sections will overheat.
2. Refer to burner manual for start-up.
3. Allow heater to heat to design condition.
4. Using combustion test equipment, adjust burner for:
  - a. a trace of smoke between #0 smoke and #1 smoke.
  - b. over-fire draft in combustion chamber per Table 4.

**Note:** For JW6 F307V also see additional "Installation Instructions for Through-the-wall Venting Components" that is supplied with the JW6 F307V.

Model #	Over-fire draft in. w.c. (Pa)
307, 507	+0.06 to +0.12
657	-0.01 to -0.03
307V	+0.2 to +0.3
317, 517, 717	-0.01 to -0.03

**Table 4. Over-fire Draft Pressures**

## Routine Preventative Maintenance (By Owner/Operator)

As a precaution against fire, and to maintain an adequate flow of combustion air to the heater:

- Keep the appliance area clear and free from combustible material, gasoline and other flammable vapors and liquids.
- Keep the air ventilation openings unobstructed. If dust and lint is seen accumulating around the openings, remove it.
- Do not pile cartons, papers, or combustible materials on top, or near the heater (see Figure 1).

## Draining And Flushing

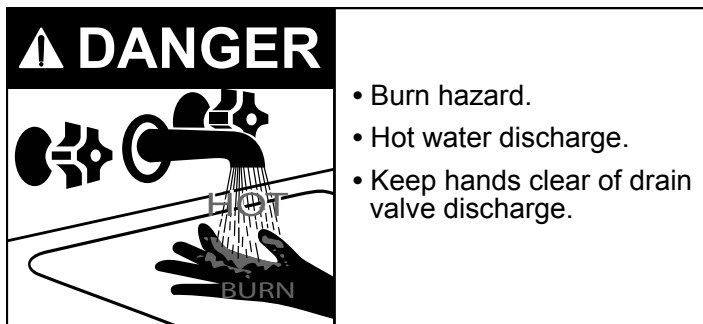

It is recommended that the tank be drained and flushed every 6 months to remove sediment that may build up during operation. The water heater should be drained if being shut down during freezing temperatures. To drain the tank, perform the following steps:

1. Turn "OFF" the electrical supply to the water heater.
2. Turn "OFF" the oil supply to the water heater.
3. Close the cold water inlet valve.
4. Open a nearby hot water faucet.
5. Connect a hose to the drain valve and terminate it to an adequate drain.

**Caution!** The water being drained can be extremely hot! The drain hose should be rated for at least 200°F. If the drain hose does not have this rating, open the cold water supply valve until the water flow is no longer hot. Close the cold water supply valve and resume.

6. Open the water heater drain valve and allow all the water to drain from the tank.
7. Flush the tank with water as needed to remove sediment.
8. Close the drain valve. Follow the instructions in the "Filling The Water Heater" section to refill the tank.
9. Turn on the oil supply to the water heater.
10. Turn "ON" the electrical supply to the water heater.

If the water heater is going to be shut down for an extended period, the drain valve should be left open.

**Important:** Condensation may occur when refilling the tank and should not be confused with a tank leak.

## Temperature And Pressure Relief Valve

Manually operate the temperature and pressure relief valve at least once a year to make sure it is working properly (see Figure 15). To prevent water damage, the valve must be properly connected to a discharge line that terminates at an adequate drain. Standing clear of the outlet (discharged water may be hot), slowly lift and release the lever handle on the temperature and pressure relief valve to allow the valve to operate freely and return to its closed position. If the valve fails to completely reset and continues to release water, immediately shut off the power to the heater and the cold water inlet valve and call a qualified service technician.

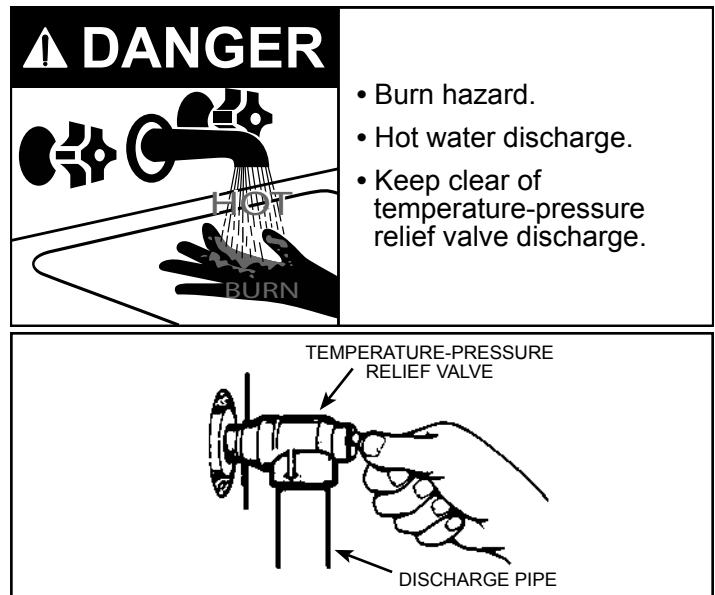

**Figure 15. T&P Valve Test**

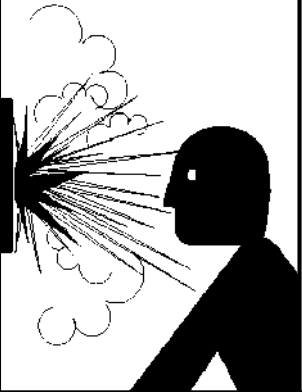
<b>⚠ WARNING</b>	
	<b>Explosion Hazard</b>
	<ul style="list-style-type: none"> <li>• Temperature-pressure relief valve must comply with ANSI Z21.22-CSA4.4 and ASME code.</li> <li>• Properly sized temperature-pressure relief valve must be installed in opening provided.</li> <li>• Do not plug, block, or cap the discharge line.</li> <li>• Failure to follow this warning can result in excessive tank pressure, serious injury or death.</li> </ul>

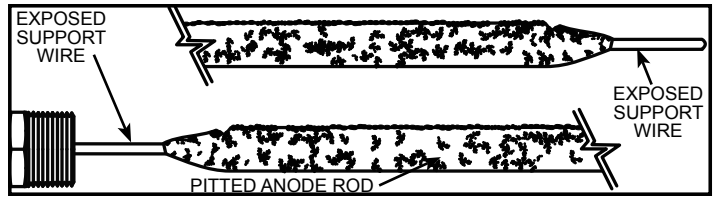

**Figure 16. Anode Rod**

9. Apply Teflon® tape, or sealing compounds approved for use with potable water, to the threads of the anode(s) and install into the tank top.
10. Open the cold water supply valve and open a nearby hot water faucet to purge air from the water tank as directed in "Filling The Water Heater".
11. Check for leaks. Repair as required, and re-test.
12. Replace the covers and insulation.
13. Turn on the oil supply to the water heater.
14. Turn "ON" the electrical supply to the water heater.

**Anode Maintenance**

<b>CAUTION</b>	
<b>Property Damage Hazard</b>	
<ul style="list-style-type: none"> <li>• Avoid water heater damage.</li> <li>• Inspection and replacement of anode rod required.</li> </ul>	

A new anode is about 13/16 in. to 7/8 in. diameter and has a steel wire core approximately 1/8 in. diameter in the center. If the anode is less than approximately 3/8 in. in diameter, or the inner steel core is exposed, the anode(s) should be replaced (see Figure 16). Operating a water heater without an actively working anode(s) will void the warranty.

**To check/replace the anode:**

1. Turn "OFF" the electrical supply to the water heater.
2. Turn off the oil supply to the water heater.
3. Close the cold water supply valve.
4. Open a nearby hot water faucet served by the system to depressurize the system.
5. Connect a hose to the drain valve and drain 6 US gallons as directed in "Draining And Flushing".
6. Close the drain valve.
7. Remove the anode cover, or, on JW F657, Rear and Combination flue models, remove top cover, insulation and flue top cover.

**Note:** The anode(s) has been factory installed using a power tool. It may be necessary for a second person to stabilize the heater. A few sharp blows on the handle of the socket wrench should loosen the anode nut. If an impact wrench (power drive) is available, this is an easier way to remove an anode.

8. Using a 1 1/16" socket (certain models require 1-5/16"), remove the anode(s) and inspect it. The surface may be rough, full of pits and crevices, but this is normal. If it is less than approximately 3/8 in. in diameter, or the inner steel core exposed, the anode(s) should be replaced.

**Valve Washer Replacement**

1. Turn "OFF" the electrical supply to the water heater.
2. Turn off the oil supply to the water heater.
3. Follow instructions in the "Draining And Flushing" section to drain the tank.
4. Turning counterclockwise (↺), remove the hex cap below the screw handle.

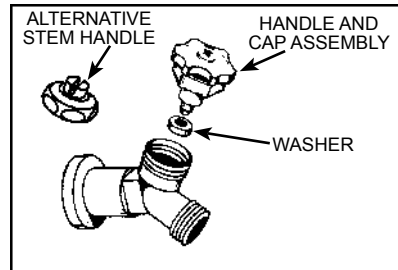

**Figure 17. Drain Valve washer replacement**

5. Remove the washer and put the new one in place.
6. Screw the handle and cap assembly back into the drain valve and re-tighten using a wrench. **DO NOT OVER TIGHTEN.**
7. Follow the instructions in the "Filling The Water Heater" section.
8. Check for leaks. Repair as needed.
9. Turn on the oil supply to the water heater.
10. Turn "ON" the electrical supply to the water heater.

**Cleaning Instructions, Flue Passages Of The JW F657 Heater**

Refer to Figure 18 for components of the heater.

1. Remove the casing top and lift the insulation off completely. It is necessary to disconnect the hot and cold water lines and move them out of the way. Do not remove the nipples from the tank.
2. Lift off the flue collector. The flue collector has a lip on the outer edge which will allow a hook to grab the edge to help lift it up.
3. Remove the flue baffles (4).
4. With a 3 in. diameter wire brush, 4 ft. long, remove any soot build-up which may be on the top head or inside the flue collector.

5. Reassemble in reverse order. It may be necessary to replace the gaskets around the nipples to seal them at the flue collector. Replace the insulation and the casing top.
6. Reconnect the plumbing lines.

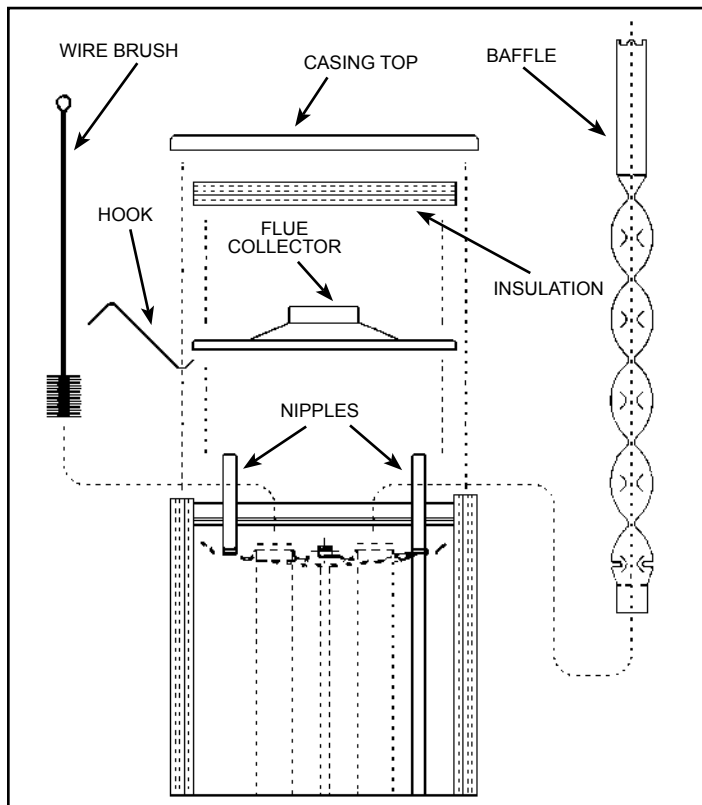

**Figure 18. Cleaning Flue Passages Of The JW F657 Heater**

#### Shut Down For Extended Periods

When away for extended periods of time such as vacation, and no freezing temperatures are expected:

1. Shut off the oil supply at the tank.
2. Shut off the cold water supply to the heater.
3. Turn "OFF" the electrical supply to the water heater.
4. Open an upstairs hot water faucet (to relieve any pressure).

When freezing temperatures are expected:

1. Shut off the oil supply at the tank.
2. Shut off the cold water supply to the heater.

**NOTE: It is recommended that all water lines in the home be drained. Contact a qualified plumber for directions applicable to the heater.**

3. Turn "OFF" the electrical supply to the water heater.
4. Connect a hose to the drain valve and drain as directed in "Draining And Flushing".
5. Leave the drain hose attached as a reminder that the tank has no water in it.

#### Re-Starting The Heater After Shut-Down

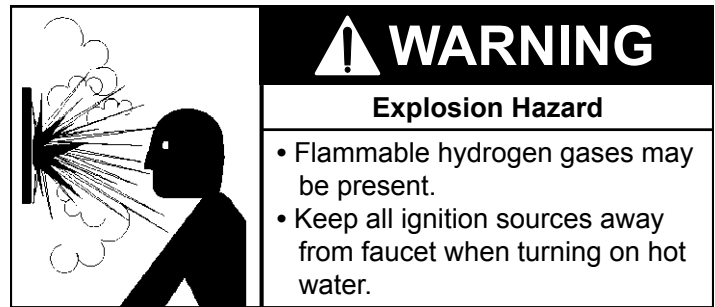

**Caution:** Hydrogen gas can be produced in a hot water system served by this heater that has not been used for a long period of time (generally two (2) weeks or more). **Hydrogen gas is extremely flammable and can ignite when exposed to a spark or flame.** To reduce the risk of injury under these conditions, it is recommended that the hot water faucet be opened for several minutes at the kitchen sink before using any electrical appliance connected to the hot water system. Use caution in opening faucets. If hydrogen is present, there will probably be an unusual sound such as air escaping through the pipe as the water begins to flow. There should be no smoking or open flame near the faucet at the time it is open.

1. Follow instructions for "Filling The Water Heater" and "Startup" when heater is ready to be put back into service.
2. If the heater does not start, check to see if the relay on the burner has tripped. Reset if necessary. Check to see if the thermostat is set at "Normal" or "High".
3. If the heater does not start:
  - a. Turn "OFF" the electrical supply to the water heater.
  - b. Shut off the oil supply at the tank.
  - c. Call a qualified Oil-Burner Technician.



## VI) COMBO HEATING

### ⚠ WARNING

Keep the area around the heater clear and unobstructed.

This section serves as a guide for the installation and use of “Combo” heating systems utilizing a domestic water heater that has been specifically approved for such use. It is written for those knowledgeable in the required trades and professionals involved in the design and installation of Combo Heating Systems.

It is the responsibility of the installer/designer to follow all applicable codes to ensure the effectiveness and safety of the installation.

This appliance has been design certified as complying with American National Standard/CSA Standard for water heaters and are considered suitable for Water (Potable) Heating and Space Heating. **Note:** This water heater may be used in combination potable water/space heating system. Do not use in a space heating only application.

### ⚠ WARNING

#### Toxic Chemical Hazard

- Do not connect to non-potable water system.

### Read Before Proceeding

### ⚠ CAUTION:

Keep safety your first priority. Take all precautions to avoid creating a fire, health or safety hazard.

The following requirements must be met for the installation of Combo Heating Systems:

1. All components used for the distribution of water in the heating loop must be suitable for potable water. These include all piping, fittings, solder and fluxes, pumps for circulation of water, valves, etc.
2. The water heater must not be connected to a hydronic heating system that has been used previously with non-potable water.
3. No boiler treatment chemicals of any kind shall be introduced into the system.
4. The Combo System components must be selected and sized to meet and maintain the total calculated demands for both domestic service hot water and space heating requirement. The sizing and installation must be performed in accordance with good engineering practice such as “ASHRAE Handbooks”, HRAI, “Hydronics Institute Manuals”, B139, NFPA 31, ANSI Z223.1, CSA F280, National/Provincial Building Codes, CSA C22.1, ANSI/NFPA 70, CSA B51 and/or codes having jurisdiction.

5. The air handler (fan coil) and/or the circulating pump in a baseboard hydronic loop will require a dedicated 120V circuit. This must be provided and identified for this purpose.
6. All piping between the water heater and the air handler or hydronic baseboard loop must be adequately insulated to reduce heat loss.
7. If the local jurisdiction requires a back-flow preventer in the cold water line, an expansion tank of adequate size must be installed.
8. “Combo” Heating Systems require higher water temperatures than other applications. When the system is used to supply water for Combo Heating applications, a means, such as mixing valve, must be installed to temper the water in order to reduce scald hazard potential (see Figure 19 through Figure 21).

### Installation

The heating mode may be one of the following options:

1. A fan coil/air handler (Figure 19).
2. A hydronic baseboard (finned tube) loop (Figure 20).
3. A hydronic in-floor heating loop (Figure 21).

The following is a list of requirements for the installation of the heating loop to the water heater.

1. Install shut-off valves and unions so that the water heater can be isolated from the heating module should servicing of the water heater become necessary.
2. Install a drain valve at the lowest point of the heating loop so that water can be drained from the heating module without affecting the water heater.
3. If the air handler does not have a venting means at the highest point of the piping arrangement, install an air bleed at the highest point of the plumbing arrangement.
4. If solenoid valves are used for zone heating applications, they must include electrical proof of valve full open position and must be connected to the water pump.

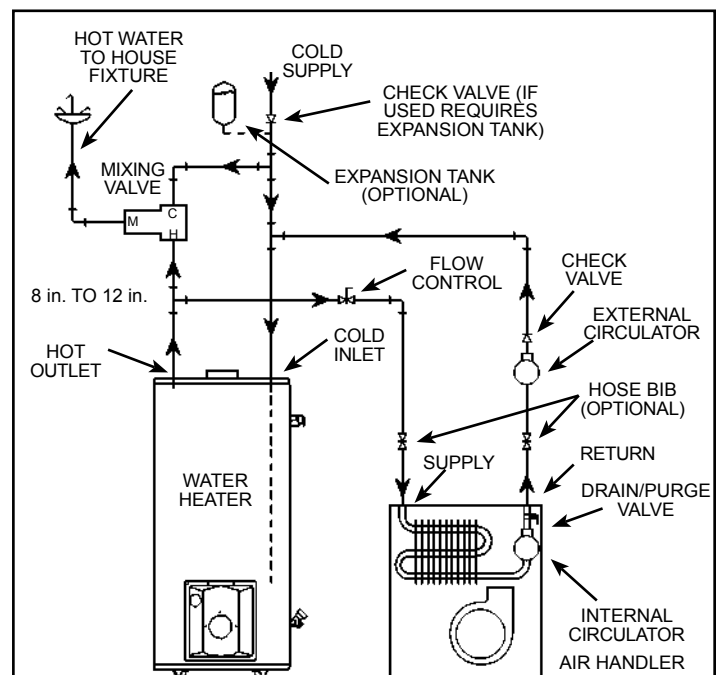

Figure 19. Combo Heating - Air Handler

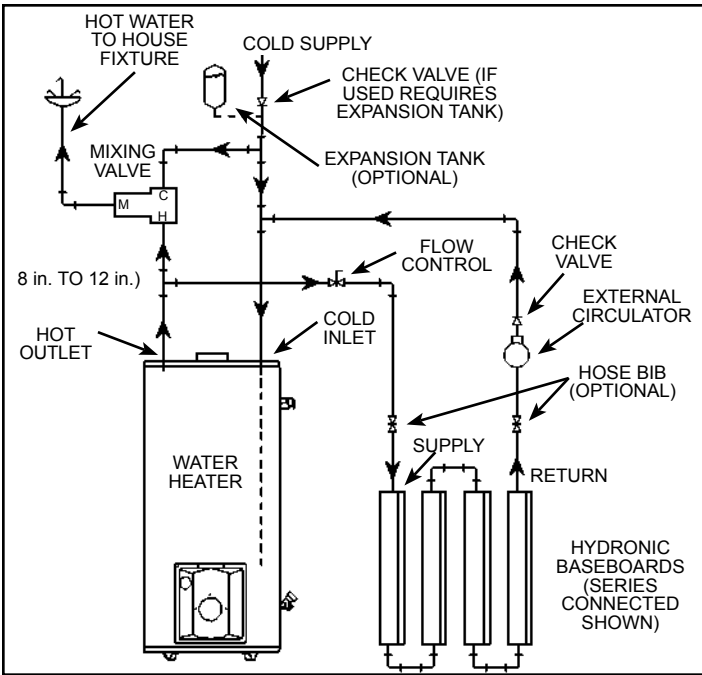

Figure 20. Combo Heating - Baseboard

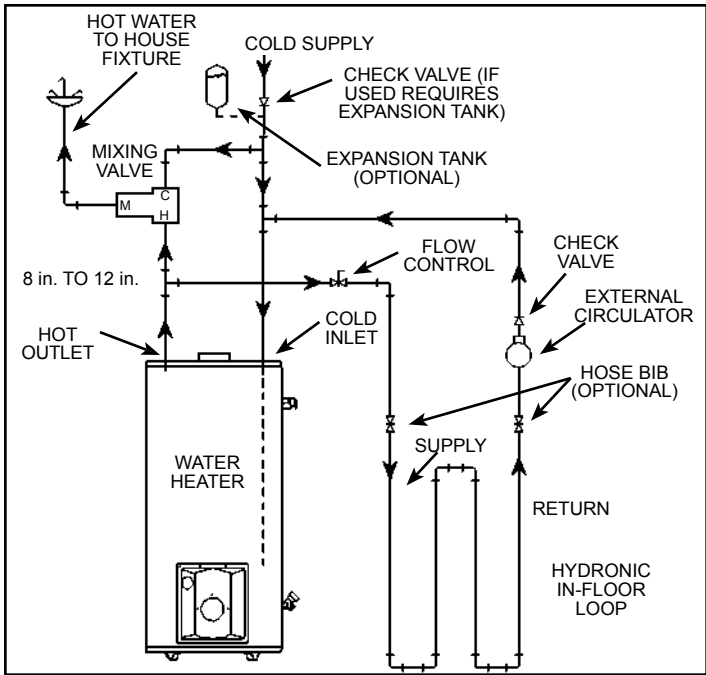

Figure 21. Combo Heating - In-Floor Loop

## VII) OIL BURNER LISTING

Model	MFGR	Burner	Nozzle
JW6 317RF	BECKETT	AFG	0.75
	CARLIN	EZ-1	0.75
JW6 517RF	BECKETT	AFG	0.85
	CARLIN	EZ-1	0.85
JW717	BECKETT	AFG	1.0
	CARLIN	EZ-1	1.0
JW6 F307	BECKETT	AFG	0.65
	CARLIN	EZ-1	0.75
	RIELLO	*	0.65
JW6 F307V	BECKETT	AFG	0.65
	CARLIN	EZ-1	0.65
	RIELLO	*	0.60
JW6 F507	BECKETT	AFG	0.75
	CARLIN	EZ-1	0.75
	RIELLO	*	0.65
JW F657	BECKETT	AFG	1.0 - 1.25
	CARLIN	EZ-1	1.0 - 1.25
	RIELLO	*	0.85 - 1.0

\* Contact your RIELLO dealer for burner specifications

**Table 5. Listing Of Oil Burners.**

INSTALLATION RECORD	
Record key data here for future reference and prompt service:	
Installed By / Purchased From:	
Installation Date:	Location of Electrical Switch or Circuit Protector:
Model Number:	Serial Number

SERVICE RECORD	
Record key data here for future reference and prompt service:	
Serviced By:	
Address:	
Telephone Number:	
Serviced Date:	



500 Tennessee Waltz Parkway, Ashland City, TN 37015  
Phone: 800-433-2545 • Fax: 800-644-9306  
[www.johnwoodwaterheaters.com](http://www.johnwoodwaterheaters.com)