

nuwave[®]
— LIVE WELL FOR LESS —

**RECIPES
INCLUDED!**

NuWave Bravo™ XL Smart Oven



Owner's Manual & Complete Recipe Book

nuwave®

LIVE WELL FOR LESS



NuWave Brio® 6Qt Digital Air Fryer

Super-heated air cooks your food to crispy, tender perfection. The digital touch screen gives you precise temperature control.

NuWave Nutri-Pot® 6Q Digital Pressure Cooker

Easily cook rice, poultry, vegetables and more all with the press of a button! The Nutri-Pot's safety release valve and hinged lid make for convenient and safe operation.

For more about our innovative products, visit:



NuWave Oven® Pro Plus

Cook healthier meals
faster and more efficiently
with Triple Combo
Cooking Power.

NuWave PIC® (Precision Induction Cooktop)

Cook faster, safer,
and more efficiently
than you ever could
on your gas or
electric stovetop.

www.nuwavenow.com

 1-877-689-2838

nuwave®
— LIVE WELL FOR LESS —



NuWave BruHub® Coffee Maker

Quality and convenience at your fingertips. The NuWave BruHub accommodates virtually all of your favorite single-serve pods, but with more flavor. Makes an 8- or 12-ounce cup and full carafe. The thermal stainless steel carafe keeps coffee hot for hours.

NuWave Moxie® High-Performance Vacuum Blender

With the simple press of a button, the NuWave Moxie can remove all the excess air from the blender. By vacuuming the air out of the blender, you can ensure no air is being mixed with your ingredients during the blending process, maximizing the nutritional value and ensuring your blender creations will remain fresh longer.

For more about our innovative products, visit:



NuWave Duralon® Healthy Ceramic Non-Stick Cookware

Coated with Duralon Healthy Ceramic Non-Stick coating for easy cleanup, this versatile cookware is perfect for use in ovens or on gas, electric, and even induction cooktops.

www.nuwavenow.com

 1-877-689-2838

TABLE OF CONTENTS

OWNER'S MANUAL

Important Safeguards	9-10
Additional Safeguards.....	11-12
Parts Description.....	13
Assembly Guide.....	14
Operating Instructions.....	15-24
Care & Maintenance	25-26
Troubleshooting	26-28
Limited Warranty.....	28-29

Breakfast

Baked Eggs in Hell	31
Homemade Granola	32

Seafood

Baked Shrimp	34
Lemon Sesame Salmon.....	35
Crab Cakes with Red Pepper Sauce	36
Fish and Chips.....	37

Poultry

Roasted Chicken.....	39
Roasted Turkey Drumsticks	40
Roasted Cornish Hen.....	41
Turkey Sliders.....	42
Baked Chicken Parmesan	43

Beef

NY Strip.....	45
Ribeye with Roasted Mushrooms.....	46
Flank Steak.....	47
Open-Faced Reuben Sandwich...	48

Pork

Pork Shoulder Roast with Potatoes	50
Baked BBQ Ribs	51

Vegetarian

Roasted Root Vegetables	53
Roasted Brussels Sprouts	54
Turmeric Roasted Cauliflower	55

Sweet Potato Fries.....	56
Goat Cheese- Stuffed Mushrooms.....	57
Baked Sweet Potatoes.....	58
Cajun-Roasted Potatoes.....	59
Oven Baked Mac and Cheese	60

Pizza

Margarita Pizza	62
Meat Lover's Pizza	63
Triple-Cheese Pizza.....	64

Dehydrate

Beef Jerky	66
Banana Chips	67
Candied Bacon	68
Croutons	69
Sun-Dried Tomatoes	70
Dried Apricots.....	71

Baking

Buttery Dinner Rolls	73
Italian Loaf	74
Frutti di Bosco.....	75

Dessert

Bread Pudding	77
Homestyle Peach Cobbler	78
Chocolate Chunk Cookies	79

Spanish

Manual	80-103
--------------	--------

12 Pre-Programmed Menus

<p>Air Fry</p> <ul style="list-style-type: none"> • Default Temp: 360°F • Default Time: 15 minutes • Heat Source: High Fan (level 3) • Rack Position: Position #1, 2, or 3 	<p>Broil</p> <ul style="list-style-type: none"> • Default Temp: 500°F • Default Time: 10 minutes • Heat Source: Top (100 percent) • Rack Position: Position #1 or 2
<p>Reheat</p> <ul style="list-style-type: none"> • Default Temp: 350°F • Default Time: 10 minutes • Heat Source: Top/Bottom (100/100 percent) • Rack Position: Any Position 	<p>Frozen</p> <ul style="list-style-type: none"> • Default Temp: 325°F • Default Time: 20 minutes • Heat Source: Top/Bottom (100/100 percent) • Rack Position: Position depends on desired result.
<p>Waffle</p> <ul style="list-style-type: none"> • Default Temp: 400°F • Default Time: 4 minutes • Heat Source: Top/Bottom (100/100 percent) • Rack Position: Position #2 or 3 	<p>Grill</p> <ul style="list-style-type: none"> • Default Temp: 400°F • Default Time: 15 minutes • Heat Source: Bottom (100 percent) • Will have a preheat • Rack Position: Position #1
<p>Bake</p> <ul style="list-style-type: none"> • Default Temp: 350°F • Default Time: 25 minutes • Heat Source: Top/Bottom (100/100 percent) • Will have a preheat • Rack Position: Position #2 or 3 	<p>Dehydrate</p> <ul style="list-style-type: none"> • Default Temp: 100°F • Default Time: 2 hours • Heat Source: Low Fan (level 1) • Rack Position: Position depends on desired result.
<p>Roast</p> <ul style="list-style-type: none"> • Default Temp: 310°F • Default Time: 25 minutes • Heat Source: Top/Bottom (100/100 percent) • Will have a preheat • Rack Position: Position #1 	<p>Toast</p> <ul style="list-style-type: none"> • Default Temp: 310°F • Default Time: 3 minutes • Heat Source: Top/Bottom (100/100 percent) • Rack Position: Position #2, 3 or 4
<p>Pizza</p> <ul style="list-style-type: none"> • Default Temp: 450°F • Default Time: 15 minutes • Heat Source: Top/Bottom (100/100 percent) • Will have a preheat • Rack Position: Position #2 or 3 • NOTE: Times & Temps will vary on the size of the pizza. 	<p>Bagel</p> <ul style="list-style-type: none"> • Default Temp: 310°F • Default Time: 3 minutes • Heat Source: Top/Bottom (100/100 percent) • Rack Position: Position #2, 3 or 4

NOTE:

- NEVER Allow any food to touch the heating elements directly.
- Default temperatures, times, and rack positions are a guide. Adjustments may need to be made to reach desired result.
- Fan speed is High (level 3) unless speed is adjusted. Dehydrate should be the lowest fan setting (level 1).

Probe Preset Temp Guide

	Beef	Chicken	Pork	Seafood
Rare	125°F	165°F	145°F	145°F
Medium-Rare	135°F			
Medium	145°F			
Medium-Well	150°F			
Well	160°F			

Measurement Chart

Teaspoon = t	Fahrenheit = °F	Minute = min
Tablespoon = T	Celsius = °C	Second = sec
Cup = C	Fluid Ounces = fl oz	Inch = in.
Ounce = oz	Liter = L	Dozen = doz
Pound = lb(s)	Milliliter = ml	Hour = hr
Quart = qt	Package = pkg.	Gram = g
Pint = pt	Gallon = gal	

IMPORTANT SAFEGUARDS

READ ALL INSTRUCTIONS

WARNING: When using the Bravo Smart Oven, basic safety precautions should always be followed:

1. Do not touch hot surfaces. Use handles and oven gloves when removing items from the Bravo.
2. Do not use the Bravo together with other electric appliance with high-power, in case of overload.
3. To protect against risk of electrical shock, do not immerse the cord, plug, or any part of the Bravo's main unit in water or any other liquids, or touch plug when hands are wet.
4. Always wear protective, insulated oven gloves when inserting or removing items from the hot oven.
5. Do not place any cookware or dishes in the Bravo that are not oven safe.
6. Do not clean with metal pads.
7. Do not operate the Bravo with a damaged cord or plug, if the appliance malfunctions, is dropped, or damaged in any manner. Contact Customer Service at 1-877-689-2838 or email help@nuwavenow.com for information on examination, repair, or adjustment.
8. Close supervision is necessary when any appliance is used near children. The Bravo is not intended for use by children, persons with reduced physical, sensory, or mental capabilities, or those with lack of expertise or knowledge of this unit.
9. Do not let the cord hang over the edge of table or counter.
10. Do not let cord contact hot surfaces, including stovetop.
11. Place the Bravo on a surface that is horizontal, even, and stable.
12. Do not place on or near a hot gas or electric burner or on a heated oven.
13. Do not place the unit close to flammable materials, heating units, or wet environments.
14. Do not place airtight containers in the Bravo.
15. Do not place plastic or rubber containers in the unit. Avoid using containers made of any other material other than ceramic, glass, or metal in the unit.
16. Do not place paper, cardboard, plastic, or any other flammable materials on the Bravo during use.
17. Use tinfoil to enwrap foods that produce oil or juice when operating and put on the bake tray, to prevent fire.
18. Make sure tinfoil does not touch heating elements, to prevent fire.
19. Do not cover crumb tray or any part of the oven with metal foil. This will cause overheating of the oven and may cause fire.
20. Do not alter or modify any part of the Bravo or use attachments or

IMPORTANT SAFEGUARDS (Continued)

accessories not recommended by the manufacturer.

21. Do not cover any part of the oven with metal foil.
22. If excess smoke is escaping from the air vent during operation, unplug the unit immediately and contact Customer Service at 1-877-689-2838 or email help@nuwavenow.com.
23. Do not overfill the Bravo such that contents are touching heating elements or blocking the fan.
24. During use, steam may be released from the air outlet vents. Keep hands and face away from the air outlet openings. Be careful of hot steam escaping when opening the Bravo.
25. Avoid placing face and eyes near the glass door during use.
26. Never touch the insides of the Bravo while it is operating.
27. Never leave the Bravo unattended during use.
28. The Bravo is intended for normal, household use. It is not intended to be used in environments such as staff kitchens, shops, offices, or other work environments. It is not intended for outdoor use.
29. Do not use the Bravo for anything other than its intended use.
30. Never put the Bravo against the wall or other appliances. There should be at least 5 inches of free space behind, to the sides of, and on top of the Bravo.
31. Do not disassemble the unit.
32. Unplug the Bravo from the outlet when not in use or before cleaning.
33. Allow the Bravo to cool before putting on, taking off parts, or before cleaning.



! WARNING

**In case of other problems, unplug unit and contact
Customer Service:
1-877-689-2838 or email help@nuwavenow.com.**

ADDITIONAL SAFEGUARDS

SEE CARE AND MAINTENANCE BEFORE USE

Electrical Information

The Bravo Smart Oven is supplied with a short power cord to reduce the risk of entanglement or tripping. Extension cords may be used if care is exercised in their use. If an extension cord is used:

1. The marked electrical rating of the extension cord should be at least as great as the electrical rating of the Bravo.
2. The longer cord should be arranged so that it will not drape over the countertop or tabletop where it could be pulled on by children or tripped over unintentionally. The Bravo should be operated on a separate electrical outlet from other operating appliances due to wattage limitations. Certain models of the appliances may have a polarized plug (one blade is wider than the other). To reduce the risk of an electric shock, this plug is intended to fit into a polarized outlet one way. If the plug does not fit fully into the outlet, reverse the plug. If the plug still does not fit properly, contact a qualified electrician. Do not attempt to modify the plug in any way.

SAVE THESE INSTRUCTIONS

Read and understand the entire manual before using this appliance.

1. Amount of ingredients placed in the Bravo should comply with directions listed under "Operating Instructions."
2. Do not move the unit while in operation.
3. Only after the Bravo has completely cooled down should you attempt to move or handle it.
4. DO NOT attempt to use the Bravo to deep-fry any food as this is NOT its intended use and may create a fire hazard.
5. Do not cover the Intake Air Vents or Exhaust Vents while the Bravo is operating.
6. Always put the ingredients to be cooked on the appropriate baking sheet (do not overfill) and do not allow food to come into direct contact with the heating components.
7. Make sure the Bravo is always clean prior to cooking.
8. It is normal for some smoke to escape the unit when heating for the first time.

ADDITIONAL SAFEGUARDS (Continued)

9. Before removing the plug from the outlet, always turn the unit "OFF".
10. Always unplug power cord by pulling on plug, NOT the cord.

NOTICE: FAILURE TO FOLLOW ANY OF THE IMPORTANT SAFEGUARDS, ADDITIONAL SAFEGUARDS, OR THE INSTRUCTIONS FOR SAFE USE IS A MISUSE OF THE BRAVO SMART OVEN THAT CAN VOID THE WARRANTY AND CREATE THE RISK OF SERIOUS INJURY.

	<p data-bbox="491 430 733 472">! WARNING</p> <p data-bbox="269 516 1000 545">Never use the Bravo with loose, damaged, or missing parts.</p>
---	--

PARTS DESCRIPTION

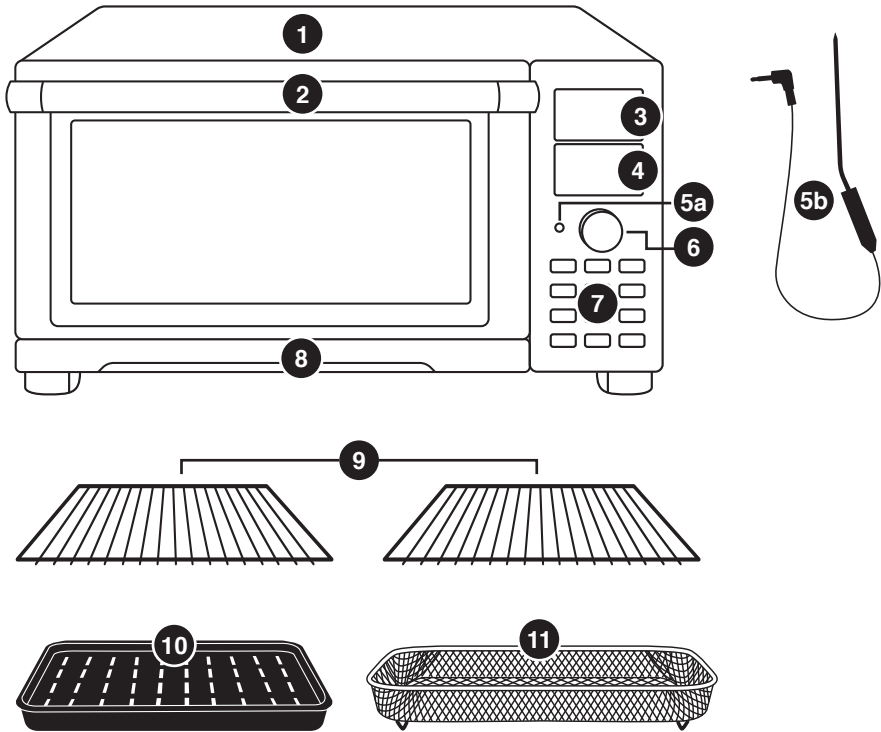

- 1** Base
- 2** Handle
- 3** Digital Display Menu
- 4** Menu
- 5a** Probe Input
- 5b** Temperature Probe
Part #: 26808
- 6** Dial
- 7** Functions
- 8** Pull-Out Crumb Tray
Part #: 26801
- 9** 2 Heavy-Duty
Cooking Racks
Part #: 26802
- 10** Enamel Baking Pan
and Enamel Broiler Rack
Part #: 26804
- 11** Air Fry Basket
Part #: 26816
- 12** Oven Light
Part#: 26807
(inside oven)

ASSEMBLY GUIDE

1. Place the Bravo on a level, even, and stable heat-resistant surface.
2. Slide the Cooking Rack(s) into either Position 1, 2, 3, or 4 of the Bravo.
3. Place Baking Pan with Broiler Rack on Cooking Rack in Position 1.
4. Place the Air Fry Basket on top of Baking Pan. It is recommended to use Air Fry Basket with Baking Pan to optimize cooking results.
5. Place Crumb Tray into position by sliding it into slot at bottom of Oven. To remove, push down slightly and pull out.
6. Plug the appliance into a standard wall socket. The power plug is located in the rear of the unit.

NOTE: Do not cover or block the intake air vents located in the back and sides of the Bravo, as doing so can prevent proper ventilation.

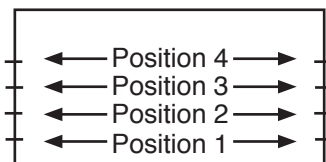
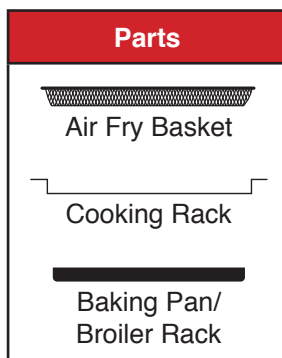

OPERATING INSTRUCTIONS

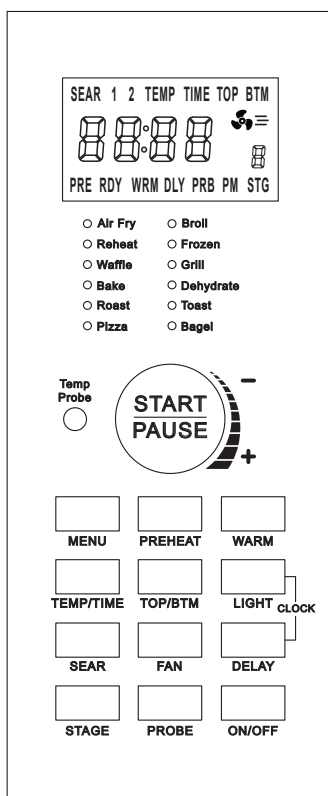

ON/OFF & START/PAUSE:

1. Press "ON/OFF" once to turn the Bravo on. The unit will beep, the LED display will show "350F" (default), TEMP, TOP, BTM, and the fan icon will be display solid.
2. Press "START/PAUSE" to begin cooking. The unit will cook at 350°F for 10 minutes. This is the default setting.
 - The LED display will show "00:10" and begin a countdown. TIME, TOP, BTM, and fan icon will be backlit and ":" will flash.
 - To adjust cooking temperature, turn the "START/PAUSE" knob toward "+" (clockwise) to increase, or toward "-" (counterclockwise) to decrease temperature in 5°F increments. Quickly turn the dial to adjust in larger increments.
 - To adjust cooking time, press "TEMP/TIME". The LED screen will display "00:10" and TIME, TOP, BTM and fan icon will be solid. Turn the "START/PAUSE" knob toward the "+" (clockwise) to increase, or toward "-" (counterclockwise) to decrease time in 1-minute increments. Quickly turn the dial to adjust in larger increments.

OPERATING INSTRUCTIONS (Continued)

- Press "TEMP/TIME" to switch LED screen display between current cooking temperature and time.
3. Press "START/PAUSE" once during cooking to pause.
 - If the LED display is on cooking time when paused, it will show remaining cooking time and TIME and ":" will be solid.
 - If the LED display is showing cooking temperature, it will show TIME and ":" will be solid.
 - During pause, only "START/PAUSE", "ON/OFF", and "LIGHT" buttons will function.
 4. Press "START/PAUSE" a second time to resume cooking. All symbols in the LED display will be solid.
 - The LED display will show remaining cooking time and continue the countdown. TIME, TOP, BTM and the fan icon will be backlit and ":" will flash.
 - Both the cooking temperature and time can be adjusted during cooking by pressing "TEMP/TIME" then turning the "START/PAUSE" knob to adjust.

CLOCK:

1. Setting the Clock:
 - Press "LIGHT" and "DELAY" at the same time. The LED display will show "00:00" and ":" will flash.
 - Turn the "START/PAUSE" knob to set the clock. When the LED display reaches "12:00", PM will be backlit.
2. Displaying Clock During Cooking:
 - Press "LIGHT" and "DELAY" at the same time. The LED display will show the current time.
 - Time can be adjusted at this time.
 - The clock time will remain on the LED display until the "START/PAUSE" knob or any other button is pressed.

LIGHT:

Default – Light Off

1. Press "LIGHT" once to turn light on.
2. Press "LIGHT" a second time to turn light off.

FAN:

Default – Level 3, Full Speed

1. Press "FAN". The LED display will show "3" above STG and the FAN icon will be solid.
 - Press "FAN" to change fan speed.
 - Fan speed can be adjusted during cooking by pressing "FAN".
2. To turn the fan off, press "FAN" until the FAN icon is no longer backlit. This indicates the fan is no longer running.

OPERATING INSTRUCTIONS (Continued)

3. Level of fan speed:
 - Level 1 – 33.33% speed
 - Level 2 – 66.67% speed
 - Level 3 – 100% speed

TOP/BTM:

Default – Top 100%, Bottom 100%. This refers to the amount of heat coming from the top and bottom heating elements.

1. Press "ON/OFF".
2. Press "TOP/BTM". LED display will show "100" and TOP will be solid. Adjust the amount of heat coming from Top heating elements by turning the "START/PAUSE" knob. Percentage will change in 10% increments.
3. Press "TOP/BTM" again. The LED display will show "100" and BTM will be solid. Again, adjust heat with "START/PAUSE".
4. When Top and Bottom heat are chosen, press "START/PAUSE". The Bravo will cook at programmed power.

NOTE: While using the Menu feature "Broil", the BTM power is not adjustable, as the Broil function only uses the top heating elements.

TEMP/TIME:

Default – 350°F, 10 minutes

1. Press "TEMP/TIME" once, LED display will show "00:10" and TIME. Press "START/PAUSE" to start cooking.
 - Turn the "START/PAUSE" knob toward "+" (clockwise) to increase time in 1-minute increments. Quickly turn the dial to adjust in larger increments.
 - Turn the "START/PAUSE" knob toward "-" (counterclockwise) to decrease time in 1-minute increments.
 - Quickly turn the dial to adjust in larger increments.
2. Press "TEMP/TIME" once. LED display will show "350F" and TEMP. Press "START/PAUSE" to start cooking.
 - Turn the "START/PAUSE" knob toward "+" (clockwise) to increase temperature in 5°F increments. Quickly turn the dial to adjust in larger increments.
 - Turn the "START/PAUSE" knob toward "-" (counterclockwise) to decrease temperature in 5°F increments.
 - Quickly turn the dial to adjust in larger increments.
3. Press "START/PAUSE" to begin cooking.
4. The Bravo will beep 3 times and the LED display will show "End" when cooking is finished.

OPERATING INSTRUCTIONS (Continued)

NOTE:

- "TEMP/TIME" can be pressed to see the current cooking temperature and current remaining cooking time.
- "START/PAUSE" knob can be turned in conjunction with pressing "TEMP/TIME" to change cooking temperature and time during cooking.
- Cooking Time range for 100F~395F is 00:00 to 99:59 and 400F~450F is 00:00 to 01:00.

PREHEAT:

1. Press "ON/OFF". Adjust cooking temperature and cooking time.
 - Turn the "START/PAUSE" knob toward "+" (clockwise) to increase temperature in 5°F increments. Quickly turn the dial to adjust in larger increments.
 - Turn the "START/PAUSE" knob toward "-" (counter clockwise) to decrease temperature in 5°F increments. Quickly turn the dial to adjust in larger increments.
2. Press "PREHEAT". The LED display will show the set cooking temperature and TEMP will be solid.
3. Press "START/PAUSE" to begin preheating.
 - During preheating, the LED display will show the selected temperature flashing along with the FAN icon, TEMP, TOP, BTM and PRE.
 - When the preheat temperature is reached, the LED display will show "5" TOP and BTM will be solid, and a 5-minute countdown will begin. RDY will be backlit.
 - The Bravo will beep to indicate oven has reached preheat temperature and food is ready to be placed into oven.
 - Carefully place food into the Bravo and press "START/PAUSE" to begin cooking.
 - If "START/PAUSE" is not pressed within the 5-minute countdown, the Bravo will automatically turn off and display Clock Time.

NOTE: Cook Time and Cook Temperature cannot be adjusted during the 5-minute holding time after preheat temperature is reached.

DELAY:

Default 1 hour.

1. Press "DELAY". "01:00", TIME, and DLY will be displayed.
 - Adjust delay time by turning the START/PAUSE knob toward the "+" (clockwise) to increase time in 1-minute increments, or turning the "START/PAUSE" knob toward the "-" (counterclockwise) to decrease time in 1-minute increments.
 - Quickly turn the dial to adjust in larger increments.
 - Maximum delay time is 99 hours, 59 minutes (99:59).
2. Press "START/PAUSE" to begin delay time countdown.
 - The set delay time will be displayed with countdown.

OPERATING INSTRUCTIONS (Continued)

- TIME will be displayed solid in LED screen during the delay time countdown. DLY and ":" will flash during the delay time countdown.
3. Once delay countdown is complete, the Bravo will begin cooking at set cooking temperature and time (default is 350°F for 10 minutes).

Using DELAY with cooking function

Example #1 Delay cooking 40 minutes, Cook at 360°F for 20 minutes :

- Press "DELAY". Adjust time to 40 minutes (00:40).
- Press "TEMP/TIME". Adjust cooking temperature. Adjust temperature to 360°F ("360F").
- Press "TEMP/TIME" a second time to adjust time to 20 minutes (00:20).
- Press "START/PAUSE". The Bravo will delay for 40 minutes, then begin to cook at 360°F for 20 minutes.

Example #2 Delay cooking 60 minutes, cook at 400°F for 10 minutes :

- Press "DELAY". Adjust time to 1 hour (01:00).
- Press "TEMP/TIME". Adjust cooking temperature to 400°F ("400F").
- Press "TEMP/TIME" a second time to adjust time to 10 minutes (00:10).
- Press "START/PAUSE". The Bravo will delay for 60 minutes, then begin to cook at 400°F for 10 minutes.

NOTE:

- Delay will always be the first function executed by the Bravo.
- The Bravo will beep 3 times and the LED display will show "End" when cooking is finished.

PRE-PROGRAMMED MENU FUNCTIONS

1. Press "ON/OFF".
2. Press "MENU". The LED display will show "360F" (default), the LED light next to "Air Fry" will be lit, and TEMP, TOP, BTM and the fan icon will be solid.
3. Press "MENU" to choose desired menu. The LED display will change depending on menu selected.
4. To change menu selection, press "MENU" until desired menu is selected.
5. Once desired menu is chosen, press "START/PAUSE" to begin cooking. The cooking time will be displayed on the LED screen.
6. The Bravo will beep 3 times and the LED display will show "End" when cooking is finished.

NOTE:

- Some menu functions require preheating. This step is pre-programmed into each menu function that requires it. Preheat functions are "Bake", "Grill", "Pizza", and "Roast".
- Once preheat temperature is reached, the Bravo will beep, and the LED display will show "5", and a 5-minute countdown will begin.

OPERATING INSTRUCTIONS (Continued)

SEAR:

Default — 450°F, 5 minutes.

Sear 1: Sear 1 will ALWAYS be the stage BEFORE the regular cooking stage.

1. Press "ON/OFF".
2. Press "SEAR" once. The LED display will show "450F", TEMP and SEAR will be backlit, and "1" will flash.
3. Press "START/PAUSE". The LED display will show SEAR 1, ":" will flash, and TIME, TOP, and BTM will be backlit.
4. The unit will "SEAR" at 450°F for 5 minutes (SEAR 1), cook at 350°F for 10 minutes (default) the unit will beep 3 times and "End" will be displayed on the LED screen, indicating cooking is complete.

NOTE: Regular cooking stage temperature and time can be adjusted by turning the "START/PAUSE" knob after Step #1.

Default — 450°F, 5 minutes.

Sear 1 2:

1. Press "ON/OFF".
2. Press "SEAR" twice. The LED display will show "450F", TEMP and SEAR 1 will be backlit, and "2" will flash.
3. Press "START/PAUSE". The LED display will show SEAR 1 and ":" will flash. TIME, TOP and BTM will be backlit.
4. The unit will "SEAR" at 450°F for 5 minutes (SEAR 1), cook at 350°F for 10 minutes (default), and "SEAR" again at 450°F for 5 minutes (SEAR 2). SEAR 2 and ":" will flash. Then unit will beep 3 times and "End" will be displayed on the LED screen indicating cooking is complete.

Sear 2: Default — 450°F, 5 minutes.

1. Press "ON/OFF".
2. Press "SEAR" three times. The LED display will show "450F", TEMP and SEAR will be backlit, and "2" will flash.
3. Press "START/PAUSE".
4. The unit will cook at 350°F for 10 minutes (default) and then unit will "SEAR" at 450°F for 5 minutes (SEAR 2). Unit will then beep 3 times and "End" will be displayed on the LED screen, indicating cooking is complete.

NOTE:

- Press "SEAR" four times to clear out the sear function.
- Maximum time for all sear functions is 5 minutes.
- Maximum temperature for all sear functions is 450°F.

OPERATING INSTRUCTIONS (Continued)

STAGE: Maximum of 5 stages can be programmed.

1. Press "ON/OFF". LED display will show "350F".
2. Press "STAGE".
 - The LED display will show TEMP and STG 2.
 - Press "TEMP/TIME". Turn "START/PAUSE" to adjust this stage's cooking temperature and time.
3. Press "STAGE" again to program another stage of cooking.
 - The LED display will show TEMP and STG and "3" will be displayed above STG.
 - Press "TEMP/TIME". Turn "START/PAUSE" to adjust this stage's cooking temperature and time.
4. Press "START/PAUSE" to begin cooking following the stages programmed.

WARM, SEAR 1, SEAR 2, AND DELAY WITH STAGE COOKING

EXAMPLE: DELAY for 1 hour » SEAR 1 350°F for 4 minutes » Cook stage 1 at 325°F for 20 minutes » cook stage 2 at 300°F for 40 minutes » cook stage 3 at 350°F for 10 minutes » SEAR 2 at 400°F for 5 minutes » WARM at 125°F for 30 minutes.

1. Press "ON/OFF". Adjust temperature to 325°F by turning "START/PAUSE". LED display will show "325F" and TEMP. Press "TEMP/TIME". Adjust time to 20 minutes by turning "START/PAUSE". LED display will show "00:20" and TIME.
2. Press "DELAY". Adjust time to 1 hour by turning "START/PAUSE" knob. LED display will show "01:00", DLY, and TIME.
3. Press "SEAR" one time. Adjust temperature to 350°F by turning "START/PAUSE". Press "TEMP/TIME". Adjust time to 4 minutes by turning "START/PAUSE". LED display will show "01:00", DLY, TIME, and SEAR and "1" will flash.
4. Press "STAGE". Adjust temperature to 300°F by turning "START/PAUSE" knob. Press "TEMP/TIME". Adjust time to 40 minutes by turning "START/PAUSE". LED display will show STG 2, "00:40", TIME, TOP, BTM, and the fan icon.
5. Press "STAGE" again. Adjust temperature to 350°F by turning "START/PAUSE". Press "TEMP/TIME" and adjust time to 10 minutes by turning "START/PAUSE". LED display will show STG 3, "00:40", TIME, TOP, BTM, and the fan icon.
6. Press "SEAR" again. Adjust temperature to 400°F by turning "START/PAUSE". Press "TEMP/TIME". Adjust time to 5 minutes by turning "START/PAUSE". LED display will show SEAR 1, "00:05", and TIME, and "2" will flash.

OPERATING INSTRUCTIONS (Continued)

- Press "WARM". Adjust temperature to 125°F by turning "START/PAUSE". Press "TEMP/TIME". Adjust time to 30 minutes by turning "START/PAUSE". LED display will show WRM, "00:30", and TIME.
- Press "START/PAUSE" to begin cooking process.

NOTE:

- During cooking, the Bravo will show all functions programmed for that cooking cycle.
- The function that the Bravo is currently cooking in will flash.
- The remaining time for that function or stage will countdown and ":" will flash. The remaining functions for that cycle will remain backlit.
- As each function ends its cooking the icons will stop being lit.

WARM:

Default 140°F, 1 hour.

- Press "ON/OFF". LED display will show "350F".
- Press "WARM". "140F" (default) will appear on the LED display along with TEMP and WRM.
 - Adjust warm temperature by turning "START/PAUSE" toward "+" (clockwise) to increase, or toward "-" (counterclockwise) to decrease temperature in 5°F increments. Quickly turn the dial to adjust in larger increments. Temperature range is 100°F~450°F.
 - Adjust warm time by turning "START/PAUSE" toward "+" (clockwise) to increase, or toward "-" (counter clockwise) to decrease time in 1-minute increments. Quickly turn the dial to adjust in larger increments.
 - 100F~395F, selectable time is 00:00 to 99:59.
 - 400F~450F, selectable time is 00:00 to 01:00.
 - WRM will appear on the LED display whenever the warm function is used.
- Press "START/PAUSE" to begin cooking.

NOTE: Warm will always be the last cooking function executed by the Bravo. The fan is not on during the warm function.

NOTE: The order of cooking function is as follows:
PREHEAT » SEAR 1 » COOKING » SEAR 2 » WARM » END

PROBE: Insert Temperature Probe into food. Place food into oven, leaving enough of the wire to exit the oven over the top of the door. (see diagram).

Insert the Temperature Probe Jack into the Probe Input.

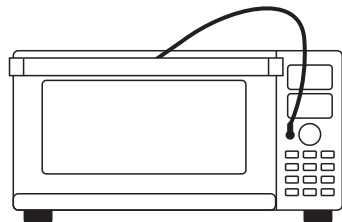

OPERATING INSTRUCTIONS (Continued)

Default 140°F, 10 minutes.

1. Press "ON/OFF". Adjust to desired cooking temperature.
2. Press "PROBE". "140F" (default) will appear on the LED display along with TEMP and PRB.
 - Adjust the temperature to the desired internal cooked temperature. Temperature range is 100°F~210°F. Adjust cooking time. Time range is 1 minute to 99 hours, 59 minutes (00:01–99:59).

NOTE: The Bravo will cook until Probe temperature is reached. If time runs out before Probe temperature is reached, the unit will continue to cook until the Probe temperature is achieved.





3. Press "START/PAUSE". The LED display will show Current Internal Probe Temperature, TEMP, TOP, BTM, and PRB.
 - Press "TEMP/TIME" to display the set cooking temperature (default is 350°F).
 - Press "PROBE" & "STAGE" together to display the set temperature of the Probe. This can be adjusted during cooking by turning the "START/PAUSE".
 - Press "PROBE" to display the current Internal Probe temperature.
4. Once the Internal Probe reaches the set temperature the Bravo will stop cooking and "End" will be displayed on the LED screen.

NOTE:

- When the Probe is unplugged and "PROBE" is pressed, "Prob" (error) will be displayed followed by 3 short beeps. This indicates "PROBE" was pressed, but that the probe was not inserted into the Probe Jack Input.
- If cooking temperature is set lower than the set Probe Temperature, "Prob" (error) will be displayed followed by 3 short beeps once user presses "START/PAUSE".
- If Probe temperature was not reached after preset cooking time has finished, the unit will continue cooking. Meanwhile, if user presses "TEMP/TIME" twice to see remaining cooking time, it will display "00:00" and stay at "00:00", indicating that the preset cooking time has run out.
- To cancel any function or stage during the cooking cycle, simply press "TEMP/TIME" (if not in cooking time countdown) and turn "START/PAUSE" until time reads "00:00". This will stop that function and move to the next function in the cooking cycle.

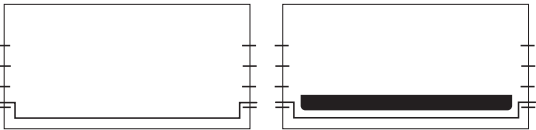
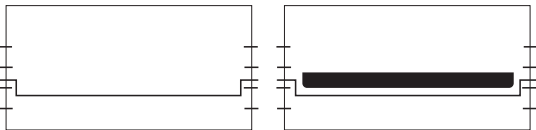
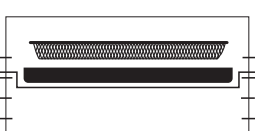
OPERATING INSTRUCTIONS (Continued)

Oven Rack And Pan Positions

<p>Position 1: Air Fry, Reheat, Roast, Broil, Frozen, Grill, & Dehydrate</p>		
<p>Position 2: Air Fry, Reheat, Waffle, Bake, Pizza, Broil, Frozen, Dehydrate, Toast, and Bagel</p>		
<p>Position 3: Air Fry, Reheat, Waffle, Bake, Pizza, Frozen, Dehydrate, Toast, and Bagel</p>		<p>Parts</p>  <p>Air Fry Basket</p>  <p>Cooking Rack</p>  <p>Baking Pan/ Broiler Rack</p>
<p>Position 4: Reheat, Frozen, Dehydrate, Toast, and Bagel</p>		

NOTE: For chicken or other large items, use Position 1 as shown above.

Helpful Hints

1. To add more time during current cooking cycle, turn "START/PAUSE" clockwise. Monitor food to ensure it doesn't overcook.
2. Some moisture may appear on the door during certain cooking cycles.
3. When air-frying, food can be lightly coated with oil to boost crispness and browning.

CARE & MAINTENANCE

Before First Use:

Wash all removable parts¹ in warm, soapy water or in the dishwasher, top rack only.

1. Remove all the packaging materials.
2. Remove the glue and labels on the appliance.
3. Clean the Cooking Racks, Baking Pan, Broiler Rack, Air Fry Basket and Crumb Tray thoroughly with hot water, a nonabrasive sponge, and mild dish detergent, or in the dishwasher, top rack only.
4. Rinse the Pizza Stone with hot water before use. Allow the stone to dry at least 30 minutes then place in a very hot oven for 30-45 minutes. Turn off oven and allow the Pizza Stone to completely cool before touching.
5. Wipe the insides and outside of the appliance with a damp dishcloth or wet cloth and dry thoroughly.

CAUTION: Do not immerse the Bravo in water.

CAUTION: Do not immerse unit in water or attempt to cycle through dishwasher.

Clean After Each Use:

1. Allow the unit to cool completely before cleaning.
2. Always unplug the Bravo from the electrical outlet. NEVER clean the unit while it is plugged in.
3. Never use harsh abrasive or corrosive products cleaners, as they may damage the finish or oven surface. Wipe the exterior with a clean, damp cloth and dry thoroughly.
4. Apply the cleaning agent directly to a cloth towel, not directly to the unit, before cleaning.
5. To clean interior, use a damp cloth, mild liquid soap solution, and a clean cloth towel.
6. Never use steel wool pads, etc., on interior or exterior of oven.
7. NEVER HANDLE A HOT PIZZA STONE. Allow the pizza stone to completely cool before cleaning. Once cooled, wipe the stone with a clean damp towel then rinse in a sink with cool water and dry completely. WARNING: NEVER submerge or rinse a hot pizza stone in water. The hot stone may crack and break underwater, causing injury.
8. When the glass window is completely cool, spray glass cleaner on a clean cloth towel. Clean both inside and outside of window. Use a damp cloth to rinse the window then dry completely with a clean dry towel.



¹ Pizza Stone is optional. ALL accessories (EXCEPT pizza stone) should be hand-washed in hot, soapy water.

CARE & MAINTENANCE (Continued)

- To remove crumbs, slide out the Crumb Tray and discard crumbs. Wipe clean and replace. Crumb Tray should be emptied and cleaned after each use.
- To remove baked-on grease, soak Tray in hot, soapy water. Never operate the oven without the Crumb Tray in place.
- Never wrap the cord around the Bravo.

Storage

- Unplug the Bravo and let unit cool down completely.
- Make sure that all parts are cleaned and dry.

TROUBLESHOOTING

The Bravo was engineered with an automatic shut-off feature to prevent overheating during use. If the Bravo shuts off to cool itself down, an odor may be detected. Unplug the unit and wait for it to completely cool down. To prevent the Bravo from overheating, do not cook foods at higher temperatures or longer times than recommended.

Problem:	Possible Cause(s):	Solution(s):
The Bravo does not work.	The appliance is not plugged in. Did not press "ON/OFF" button.	Insert the plug into an appropriate grounded power socket. Press "ON/OFF". If still not working, contact Customer Service at 1-877-689-2838 or email help@nuwavenow.com .
The door to Bravo will not close completely.	Food item is too large. Oven racks or accessories are not properly set in place.	Use smaller amounts of food to cook. Make sure all racks and pans are slid into place and pushed all the way to the back of the unit.
The food is cooked unevenly.	Depending on size and amount, some foods may need to be turned or rotated throughout cooking.	Check cooking progress throughout. Turn or rotate as needed to ensure even cooking.

TROUBLESHOOTING (Continued)

Problem:	Possible Cause(s):	Solution(s):
Bake vs. Roast vs. Broil	When to use these three functions.	Use Bake when cooking items that rise (i.e., cakes and cookies). Use Roast for dense foods that are browned throughout the cooking process. Use Broil to quickly brown or crisp a food item.
The Crumb Tray will not slide back into position.	The Crumb Tray is not placed into the slot correctly. Something is blocking the Tray from sliding into position.	Remove the Crumb Tray and clean away any food items that may have accumulated in the back of the Bravo.
White smoke is coming out of the product.	You are cooking greasy foods. The Baking Pan contains greasy residue from previous uses. When preparing greasy ingredients in the unit, large amounts of oil can smoke. The oil will produce white smoke. This will not affect the final cooking effect. White smoke is caused by grease heating up on the wire racks and/or Crumb Tray.	Clean Cooking Racks and Crumb Tray regularly between use.
The LED screen is blank.	Unit overheated and has shut itself down. No action was taken after certain stages of cooking and unit shut down. Control Panel not working correctly.	Unplug the Bravo and allow the unit to completely cool. Plug back in and see if it is working. If the LED screen remains blank, contact Customer Service at 1-877-689-2838 or email help@nuwavenow.com .
The Bravo is not heating.	Unit is unplugged. Unit has overheated. Heating elements not working.	Make sure the Bravo is plugged in. Make sure the unit is completely cooled. Plug in and see if unit comes up to correct temperature. If unit continues to not heat up, contact Customer Service at 1-877-689-2838 or email help@nuwavenow.com .

TROUBLESHOOTING (Continued)

If the Bravo needs to be replaced or returned to the manufacturer, contact Customer Service at 1-877-689-2838 or email: help@nuwavenow.com

Contact Customer Service if any of these errors occur:

Code	Er1	Er2	Er3	Er4
"Prob" Error	Probe short circuit	NTC short circuit	NTC open	NTC overheated

LIMITED WARRANTY

The Bravo XL Smart Oven

THE MANUFACTURER WARRANTS

The Bravo, including the Power Base, Heavy-Duty Cooking Racks, Enamel Baking Pan, Enamel Broiler Rack, Chrome-Plated Air Fry Basket, Pull-Out Crumb Tray, Temperature Probe, and all electrical components are warrantied for 3 years from the date of purchase, under normal household use, and when operated in accordance with the Manufacturer's written instructions.

The Manufacturer will provide the necessary parts and labor to repair any part of the Bravo at the NuWave, LLC Service Department. After the expiration of the warranty, the cost of the labor and parts will be the responsibility of the owner.

THE WARRANTY DOES NOT COVER

The Limited Warranty is voided if repairs are made by an unauthorized dealer and/or the serial number data plate is removed and/or defaced. Normal deterioration of finish due to use or exposure is not covered by this Warranty. This Limited Warranty does not cover failure, damages or inadequate performance due to accident, acts of God (such as lightning), fluctuations in electric power, alterations, abuse, misuse, misapplications, corrosive-type atmospheres, improper installation, failure to operate in accordance with the Manufacturer's written instructions, abnormal use or commercial use. NuWave, LLC reserves the right to void the Limited Warranty, where allowable by law, for products purchased from an unauthorized dealer.

LIMITED WARRANTY (Continued)

TO OBTAIN SERVICE

The owner shall have the obligation and responsibility to: pay for all services and parts not covered by the warranty; prepay the freight to and from Service Department for any part or system returned under this warranty; and carefully package the product using adequate padding material to prevent damage in transit. The original container is ideal for this purpose. Include in the package the owner's name, address, daytime telephone number, a detailed description of the problem, and your **"RGA number."** **Call 1-877-689-2838 or email help@nuwavenow.com** to obtain the **RGA** number (Return Goods Authorization number). Provide the cooking system model & serial number and proof of date of purchase (a copy of the receipt) when making claims under this warranty.

MANUFACTURER'S OBLIGATION

The Manufacturer's obligation under this Limited Warranty is limited, to the extent allowable by law, to repairing or replacing any part covered by this Limited Warranty which upon examination is found to be defective under normal use. The Limited Warranty is applicable only within the continental United States and only to the original purchaser of the manufacturer's authorized channels of distribution. **THE LIMITED WARRANTY MAY NOT BE ALTERED, VARIED OR EXTENDED EXCEPT BY A WRITTEN INSTRUMENT EXECUTED BY THE MANUFACTURER. THE REMEDY OF REPAIR OR REPLACEMENT AS PROVIDED UNDER THIS LIMITED WARRANTY IS EXCLUSIVE. IN NO EVENT SHALL THE MANUFACTURER BE LIABLE FOR ANY CONSEQUENTIAL OR INCIDENTAL DAMAGES TO ANY PERSON, WHETHER OR NOT OCCASIONED BY NEGLIGENCE OF THE MANUFACTURER, INCLUDING WITHOUT LIMITATION, DAMAGES FOR LOSS OF USE, COSTS OF SUBSTITUTION, PROPERTY DAMAGE, OR OTHER MONEY LOSS.**

Some states do not allow the exclusion or limitation of incidental or consequential damages, so the above limitation exclusions may not apply. This Limited Warranty gives specific legal rights, and there may also be other rights which vary from state to state. **EXCEPT AS OTHERWISE EXPRESSLY PROVIDED ABOVE, THE MANUFACTURER MAKES NO WARRANTIES EXPRESSED OR IMPLIED ARISING BY LAW OR OTHERWISE, INCLUDING WITHOUT LIMITATION, THE IMPLIED WARRANTIES OF MERCHANTABILITY AND FITNESS FOR A PARTICULAR PURPOSE TO ANY OTHER PERSON. READ YOUR OWNER'S MANUAL. IF YOU STILL HAVE ANY QUESTIONS ABOUT OPERATION OR WARRANTY OF THE PRODUCT, PLEASE CONTACT NUWAVE, LLC.**

READ YOUR OWNER'S MANUAL

If you still have any questions about operation or warranty of the product, please contact **NuWave, LLC at: 1-877-689-2838 or email help@nuwavenow.com**.

Breakfast



nuwave
— LIVE WELL. FEEL LESS. —



Baked Eggs in Hell

Serves: 2

Ingredients:

4 eggs
2 red peppers, roasted
5 dried arbol chiles
1 roma tomato
Pinch of salt and pepper
Pinch of chili flake

Directions:

1. In a blender or food processor combine all ingredients except for your eggs.
2. Pour your sauce into an oven safe bowl or dish.
3. Crack 4 eggs into sauce, removing some of the egg white.
4. Place bowl onto the Cooking Rack on the lowest position and set Bravo to "Bake" at 350°F for 20 minutes.
5. Once finished carefully remove the bowl from the Bravo.
6. Serve eggs with toasted bread or top with cheese and enjoy.



Homemade Granola

Serves: 2

Ingredients:

- 2 C oats
- ¼ C almonds
- ¼ C cashews
- ¼ C pecans
- ¼ C raisins
- ¼ C dried cranberry
- 3 T maple syrup
- 1 t vanilla extract
- Pinch of salt
- 3 T coconut oil

Directions:

1. In a large mixing bowl combine all your ingredients.
2. Set your Bravo to "Dehydrate" and set the preheat to 300°F.
3. Place your granola mixture onto the Baking Pan with Cooking Rack on the lowest position and carefully set inside the Bravo.
4. Dehydrate your mixture for 5 hours at 120°F.
5. Once finished carefully remove the Baking Pan from the Bravo and let cool.
6. Serve after cooling or store in a container for up to 2 weeks.

Seafood



nuwave
— LIVE WELL FOR LESS —



Baked Shrimp

Serves: 2

Ingredients:

- 1 ½ lb shrimp, peeled and devained
- 1 lemon, juiced
- 2 T butter, softened
- 4 cloves garlic, minced
- Pinch of salt and pepper
- Pinch of chili flakes
- 2 T parsley (garnish)

Directions:

1. In a bowl combine all ingredients and coat shrimp.
2. Place shrimp onto Baking Pan with Cooking Rack and place in the middle position in your Bravo.
3. Set your Bravo to "Bake" at 425°F for 10 minutes.
4. Once finished sprinkle parsley over the top. Serve and enjoy.



Lemon Sesame Salmon

Serves: 2

Ingredients:

2-8 oz salmon filets, skin on
2 T honey
½ lemon juiced
2 t soy sauce
1 T sesame seeds

Directions:

1. In a bowl combine honey, soy sauce, lemon juice, and sesame seeds.
2. Place filets on a greased Baking Pan and coat with sesame glaze.
3. Place salmon on the Cooking Rack in the middle position and set the Bravo to "Bake" at 400°F for 12 minutes until fish flakes easily with a fork.
4. Carefully remove from the oven, serve and enjoy.



Crab Cakes with Roasted Red Pepper Sauce

Serves: 4

Ingredients:

For Crab Cakes:

- 1 C cracker meal
- 1 egg, beaten
- ½ C milk
- 12 oz. jumbo lump crab meat
- 1 T baking powder
- 1 bunch parsley, chopped
- 1 lemon, zested
- 1 stalk celery, fine dice

- 2 T mayonnaise
- Extra-virgin olive oil
- Lemon wedges for garnish

For Red Pepper Sauce:

- 1 (8-oz) jar roasted red peppers, drained
- 1 C mayonnaise
- ½ C chili sauce

Directions:

1. In a large mixing bowl, add cracker meal and create a well in the center of the meal.
2. Combine the egg and milk and add to the well in the cracker meal. Using a fork, combine the cracker meal and liquid together to moisten the meal.
3. Add crab, baking powder, parsley, lemon zest, celery and mayonnaise. Mix well to combine.
4. Form crab cake patties, place on the Baking Pan and brush with olive oil on both sides. Place Baking Pan on Cooking Rack in oven and set oven to 375°F for 15 minutes.
5. Bake until golden brown and serve with red pepper sauce and lemon wedges.

For Red Pepper Sauce:

1. Add red peppers to a food processor or blender. Add mayonnaise and chili sauce.
2. Pulse the mixture until everything is combined and it has reached the desired consistency.



Fish and Chips

Serves: 4

Ingredients:

For Chips:

3 Idaho potatoes, ¼-inch sticks
¼ C extra-virgin olive oil
Fresh cracked black pepper
Sea Salt

For Fish:

2-¾ C cornflakes, crushed
3 egg whites
1-½ lbs white fish, boneless, skinless,
3-inch pieces
Sea salt
Black pepper, ground
Cooking spray

Directions:

1. Place Cooking Rack in position 3. Place the Baking Pan on the Cooking Rack and preheat the oven to 450°F.
2. Place potatoes, oil, salt and pepper in a mixing bowl and coat the potatoes.
3. When the Baking Pan is hot and the oven is preheated, carefully remove the Baking Pan and layer the potatoes on the Baking Pan evenly.
4. Place the Baking Pan with potatoes in the oven and cook for 20-25 minutes or until potatoes are golden brown and crispy. Turn half way through cooking to ensure even browning.
5. While the chips cook, place a Baking Pan on top of another Cooking Rack and spray with cooking spray.
6. Add cornflakes to a mixing bowl along with salt and pepper to taste.
7. In a second mixing bowl, combine egg whites and a pinch of salt and whisk until frothy.
8. Dip the fish into the egg whites and then coat in cornflakes to cover. Place fish on Baking Pan and place on Cooking Rack on position 1 of the oven.
9. Bake for 10 to 12 minutes or until fish is golden brown and crisp. Serve with chips, lemon wedges and tarter sauce (optional).

Poultry



nuwave
LIVE WELL FOR LESS.



Roasted Chicken

Serves: 4

Ingredients:

- 1- 4 lb whole chicken, giblets and neck removed
- 3 T olive oil
- 1 lemon, juiced
- Pinch of salt and pepper
- 5 cloves garlic
- 4 sprigs rosemary

Directions:

1. Pat chicken dry with paper towel then toss chicken in oil.
2. Season chicken with salt, pepper, and lemon juice.
3. Place garlic and rosemary into the cavity of the chicken.
4. Place the chicken onto the Broiler Rack with Baking Pan and set onto the Cooking Rack placed on the lowest level.
5. Set the Bravo to 425°F for 1 hour. (internal temp of 165°F).
6. Once finished carefully remove the chicken and let rest for 5 minutes. Serve and enjoy.



Roasted Turkey Drumsticks

Serves: 2

Ingredients:

2-10 oz turkey drumsticks, skin-on
Pinch of salt and pepper
1 t paprika
1 t thyme
2 t garlic powder
2 T olive oil

Directions:

1. Pat drumsticks dry with paper towel.
2. Once dried, coat the drumsticks with olive oil and season with your dry ingredients.
3. Place drumsticks on Broiler Rack with Baking Pan and set onto Cooking Rack in the lowest position.
4. Set the Bravo to "Roast" at 450°F for 35 minutes.
5. Once turkey drumsticks are finished carefully remove from the oven and let rest for 5 minutes. Serve and enjoy.



Roasted Cornish Hen

Serves: 6

Ingredients:

2 Cornish hens
1 yellow onion, quartered
4 stalks celery, large dice
3 T olive oil
Pinch of salt and pepper
4 cloves garlic
2 T chili powder

Garnish:

4 T parsley, chopped

Directions:

1. In a small bowl combine all of your dry ingredients.
2. Rub hens with oil and season with dry seasoning mixture.
3. Stuff the cavities with onion, celery, and garlic.
4. Place hens onto Broiler Rack with Baking Pan and place onto the Cooking Rack on the lowest position.
5. Set your Bravo to "Roast" at 375°F for 45 minutes.
6. Use probe to check the internal temperature of your hens (should be 165°F).
7. Once finished carefully remove and let rest for 5 minutes. Serve and enjoy.



Turkey Sliders

Serves: 8

Ingredients:

- 1 lb ground turkey
- ½ C bread crumbs
- Pinch of salt and pepper
- 2 cloves garlic, minced
- ¼ onion, minced
- ¼ T ground mustard
- 8 slider buns.

Garnish:

- Tomato
- Pickles
- Cheese
- Mayo
- Lettuce

Directions:

1. In a bowl combine all ingredients except the buns.
2. Form mixture into patties and place onto the greased Baking Pan.
3. Set Baking Pan onto the Cooking Rack in the middle position.
4. Set Bravo to "Grill" at 375°F for 20 minutes.
5. Once finished carefully remove from the oven.
6. Place patties onto your buns and top with your favorite garnish. Serve and enjoy.



Baked Chicken Parmesan

Serves: 4

Ingredients:

- 2 chicken breast, butterflied (to make 4)
- $\frac{3}{4}$ C panko breadcrumbs
- $\frac{1}{3}$ C Parmesan cheese
- 2 T olive oil
- $\frac{3}{4}$ C mozzarella cheese
- 1 C marinara sauce

Directions:

1. In a bowl combine breadcrumbs and Parmesan cheese.
2. Coat the chicken in olive oil and dip into the breadcrumb mixture.
3. Place chicken onto the greased Baking Pan and place onto the Cooking Rack on the lowest setting.
4. Set the Bravo to "Bake" at 450°F for 20 minutes.
5. Carefully remove the Baking Pan from the oven and spoon marinara sauce over the cooked chicken. Then top with mozzarella cheese.
6. Place Baking Pan back into the oven and set to "Broil" for 3 minutes.
7. Once finished, carefully remove from the Bravo and let rest for 3 minutes. Serve and enjoy.

Beef



nuwave[®]
— LIVE WELL FOR LESS —



NY Strip

Serves: 2

Ingredients:

2- 1 inch thick NY Strip Steaks

$\frac{1}{3}$ C olive oil

Pinch of salt and pepper

Garnish:

Goat cheese

Chives

Directions:

1. Brush your strips with olive oil and season generously with salt and pepper.
2. Place your steaks onto a greased Baking Pan and place onto Cooking Rack on the lowest position.
3. Set Bravo to "Roast" for 425°F for 8 minutes.
4. Once finished carefully open the Bravo and remove the steak.
5. Garnish with goat cheese and chives.



Ribeye with Roasted Mushrooms

Serves: 2

Ingredients:

- 2-1 inch thick ribeye steaks
- 3 T butter, melted
- 2 cloves garlic, minced
- Pinch of salt and pepper
- 1 pack of crimini mushrooms, sliced

Directions:

1. Melt your butter and stir in mixed garlic.
2. Brush your steaks with butter and season with salt and pepper.
3. Set your steaks and mushrooms onto a greased Baking Pan and place onto the Cooking Rack on the middle position.
4. Set your Bravo to "Roast" on 450°F and cook for 8-10 minutes.
5. Once finished carefully remove from oven and let rest for 3 minutes. Serve and enjoy.



Flank Steak

Serves: 4

Ingredients:

- 1 lb flank steak
- 2 T olive oil
- 3 cloves garlic, minced
- 2 T cajun spice
- Pinch of salt and pepper

Directions:

1. In a bowl marinate your steak in olive oil, garlic, cajun spice, salt, and pepper.
2. Marinate for 3 hours up to 1 day.
3. Place your steak onto a greased Baking Pan and place into your Bravo on the Cooking Rack set on the middle position.
4. Set your Bravo to "Broil" on 500°F for 4 minutes per side.
5. Once finished remove steak and let rest for 5 minutes.
6. Slice your steak and serve with roasted vegetables.



Open-Faced Reuben Sandwich

Serves: 2

Ingredients:

- 2 slices rye bread
- ½ lb pastrami, shaved
- 4 oz sauerkraut, drained
- 4 T thousand island dressing
- 4 slices swiss cheese

Directions:

1. Build your sandwich layering dressing, sauerkraut, pastrami, and cheese.
2. Place onto a greased Baking Pan and set on Cooking Rack on the lowest position.
3. Set Bravo to "Broil" on 500°F for 4 minutes.
4. Toast sandwich until cheese is bubbly.
5. Once finished carefully remove from oven and let cool for 3 minutes. Serve and enjoy.

Pork



nuwave
LIVE WELL FOR LESS



Pork Sholder Roast with Potatoes

Serves: 6

Ingredients:

- 4 lb pork shoulder roast
- 3 T salt
- 2 T pepper
- 2 t garlic powder
- 2 t onion powder
- 2 t cayenne pepper
- 1 T olive oil
- ½ lb baby potatoes

Directions:

1. Dry your pork shoulder and season with salt, pepper, garlic, onion, and 1 t of cayenne.
2. Rub spices into the shoulder.
3. Once seasoned set shoulder onto Baking Pan and place onto the Cooking Rack at the lowest position.
4. In a bowl toss your potatoes in oil and season with salt and 1 t of cayenne pepper. Add the Broiler Rack as well.
5. Set your Bravo to "Roast" at 400°F for 45 minutes.
6. Once finished set to "Broil" and crisp the skin for 5 minutes.
7. Carefully remove from the oven, serve and enjoy.



Baked BBQ Ribs

Serves: 4

Ingredients:

- 1 rack of ribs
- 1 t cayenne pepper
- $\frac{1}{3}$ C brown sugar
- 1 T cumin
- 2 T black pepper
- 1 t ground mustard
- 1 C BBQ sauce

Directions:

1. In a bowl combine all dry ingredients.
2. Season your rack of ribs with dry rub.
3. Set your Bravo to "Roast" at 375°F for 55 minutes.
4. Place ribs onto Baking Pan on Cooking Rack at set at the lowest position.
5. Once there is 20 minutes left of cook time carefully open the oven and brush BBQ sauce onto the ribs.
6. Close the oven and continue to bake for the remaining time.
7. Once finished carefully remove ribs from the oven, serve and enjoy.

Vegetarian



nuwave
LIVE WELL FOR LESS



Roasted Root Vegetables

Serves: 4

Ingredients:

1 bunch, organic colored carrots, peeled
½ red onion, quartered
6 cloves garlic
1 yam, peeled, quartered
Pinch of salt and pepper
3 T olive oil

Directions:

1. Set your Bravo to "Roast" and preheat at 425°F.
2. Toss your vegetables in a bowl with olive oil and season with salt and pepper.
3. Place vegetables on Baking Pan and set pan onto middle setting in your Bravo.
4. Set your Bravo to 425°F for 35 minutes.
5. Carefully turn vegetables halfway through cooking.
6. Once finished carefully remove vegetables and serve.



Roasted Brussels Sprouts

Serves: 4

Ingredients:

- 1 lb Brussels sprouts, trimmed
- 2 T olive oil
- Pinch of salt and pepper

Directions:

1. Set your Bravo to "Roast" and preheat at 425°F.
2. Toss your brussels in a bowl with olive oil and season with salt and pepper.
3. Place brussels on Baking Pan and set Cooking Rack onto middle position in your Bravo.
4. Set your Bravo to 425°F for 35 minutes.
5. Once finished cooking carefully remove from your oven, serve and enjoy.



Tumeric Roasted Cauliflower

Serves: 6

Ingredients:

- 1 head cauliflower, cut into florets
- 4 cloves garlic
- 3 T olive oil
- ½ t turmeric
- ¼ t chili flake
- Pinch of salt and pepper

Directions:

1. Set your Bravo to "Roast" and preheat at 425°F.
2. Toss your cauliflower in a bowl with olive oil and season with salt, pepper, turmeric, and chili flake.
3. Place cauliflower on Baking Pan and set Cooking Rack onto middle position in your Bravo.
4. Set your Bravo to 425°F for 35 minutes.
5. Once finished cooking carefully remove from your oven, serve and enjoy.



Sweet Potato Fries

Serves: 4

Ingredients:

- 2 sweet potatoes, peeled and cut into wedges
- 3 T olive oil
- Pinch of salt and pepper
- ½ t red peppercorn

Garnish:

- Green Onion
- Maple Syrup

Directions:

1. Set your Bravo to "Roast" and preheat at 425°F.
2. Toss your sweet potatoes in a bowl with olive oil and season with salt, pepper, turmeric, and chili flake.
3. Place sweet potatoes on Baking Pan and set Cooking Rack onto middle position in your Bravo.
4. Set your Bravo to 425°F for 20 minutes.
5. Once finished carefully remove from the oven.
6. Garnish with green onion and maple syrup and enjoy.



Goat Cheese Stuffed Mushrooms

Serves: 4

Ingredients:

2 packs of crimini mushrooms, stems removed
Pinch of salt and pepper
3 T goat cheese, crumbled
4 T chives, sliced

Directions:

1. Set your Bravo to "Roast" and preheat at 400°F.
2. Stuff your mushrooms with goat cheese.
3. Place stuffed mushrooms on Baking Pan and set Cooking Rack onto middle position in your Bravo.
4. Set your Bravo to 400°F for 15 minutes.
5. Once finished carefully remove from the oven and garnish with sliced chives. Serve and enjoy.



Baked Sweet Potatoes

Serves: 4

Ingredients:

4 sweet potatoes
2 T olive oil
Pinch of salt

Directions:

1. Rub your sweet potatoes with olive oil and prick the potatoes with a fork. Season with salt.
2. Set your Bravo to "Bake" at 425°F for 45 minutes and place the Baking Pan on a Cooking Rack at lowest position.
3. Once finished carefully remove from the oven and let cool for 5 minutes.
4. Split open and top with butter and salt. Serve and enjoy.



Cajun Roasted Potatoes

Serves: 6

Ingredients:

- 2 lbs baby potatoes
- 1/3 C olive oil
- 2 cloves garlic, minced
- Pinch of salt and pepper
- 1/2 t cayenne pepper

Directions:

1. Set your Bravo to "Roast" and preheat at 450°F.
2. In a bowl toss your potatoes in olive oil, garlic, and cayenne pepper.
3. Place potatoes on Baking Pan and set Cooking Rack onto middle position in your Bravo. Season with salt and pepper.
4. Set your Bravo to 450°F for 40 minutes.
5. Once finished, carefully remove baking sheet from the oven. Serve and enjoy.



Oven Baked Mac and Cheese

Serves: 6

Ingredients:

- 1 lb macaroni noodles
- 4 T butter
- 4 T flour
- 2 C milk
- 3 C cheddar cheese
- Pinch of salt and pepper
- 1/3 C panko bread crumbs

Directions:

1. In a pot bring salted water to a boil and add in macaroni.
2. Cook noodles until tender, then strain the noodles.
3. In a separate pot melt your butter.
4. Once melted whisk in flour, salt, and pepper.
5. Constantly stir roux until it becomes a light brown, about 2-3 minutes.
6. Stir in 1 cup of milk and then stir in the remaining milk.
7. Once sauce thickens stir in your cheese.
8. Add the noodles to your cheese sauce and stir.
9. Add your macaroni and cheese to a cassarole dish and top with panko bread crumbs.
10. Set your Cooking Rack in the middle position and set the Bravo to "Bake" at 350°F for 12 minutes.
11. Once finished carefully remove from the oven, serve and enjoy.

Pizza



nuwave[®]
— LIVE WELL FOR LESS —



Margarita Pizza

Serves: 4

Ingredients:

Dough:

- 2 ½ C flour
- 1 t sugar
- ½ t active dry yeast
- Pinch of salt
- ½ C warm water
- 1 T olive oil

Topping:

- 1 C sun-dried tomato
- ½ C tomato sauce
- 3 cloves garlic, minced
- Pinch of salt and pepper
- 3 T grated Parmesan cheese
- 8 oz fresh mozzarella cheese
- 6 basil leaves

Directions:

1. In a bowl combine flour, sugar, yeast, and salt.
2. Add in warm water and oil and combine.
3. Scrape the dough out of the bowl onto a floured surface and knead the dough until it becomes tacky.
4. Add dough back into bowl and cover and set in a warm place.
5. Allow the dough to rise for about 1 hours and 30 minutes or until doubled in size.
6. Once dough has doubled, on a floured surface roll out your dough and form into a round crust.
7. Begin to assemble your pizza and preheat a pizza stone in your Bravo at 400°F and heat your stone.
8. Brush olive oil onto your dough, then spread tomato sauce onto the dough. Sprinkle Parmesan cheese, mozzarella cheese, and basil onto your pizza. and top with sun-dried tomato.
9. Gently slide your pizza onto the heated pizza stone and set your Bravo to "Pizza".
10. Cook for 15-18 minutes at 375°F.
11. Once finished use a pizza peel to remove pizza from stone and let rest for 3-4 minutes.
12. Slice, serve, and enjoy.



Meat Lovers Pizza

Serves: 4

Ingredients:

Dough:

- 2 ½ C flour
- 1 t sugar
- ½ t active dry yeast
- Pinch of salt
- ½ C warm water
- 1 T olive oil

Topping:

- 1 C Italian Sausage, rolled into balls
- ½ C pepperoni
- ½ C bacon, diced
- 3 cloves garlic, minced
- ½ C tomato sauce
- Pinch of salt and pepper
- 3 T grated Parmesan cheese
- 8 oz fresh mozzarella cheese
- 6 basil leaves

Directions:

1. In a bowl combine flour, sugar, yeast, and salt.
2. Add in warm water and oil and combine.
3. Scrape the dough out of the bowl onto a floured surface and knead the dough until it becomes tacky.
4. Add dough back into bowl and cover and set in a warm place.
5. Allow the dough to rise for about 1 hour and 30 minutes or until doubled in size.
6. Once dough has doubled, on a floured surface roll out your dough and form into a round crust.
7. Begin to assemble your pizza and preheat a pizza stone in your Bravo at 400°F and heat your stone.
8. Spread tomato sauce onto your crust and then layer on your toppings.
9. Gently slide your pizza onto the heated pizza stone and set your Bravo to "Pizza" with the Cooking Rack and Pizza Stone on the lowest setting.
10. Cook for 15-18 minutes at 375°F.
11. Once finished use a pizza peel to remove pizza from stone and let rest for 3-4 minutes.
12. Slice, serve, and enjoy.



Triple Cheese Pizza

Serves: 4

Ingredients:

Dough:

- 2 ½ C flour
- 1 t sugar
- ½ t active dry yeast
- Pinch of salt
- ½ C warm water
- 1 T olive oil

Topping:

- ½ C tomato sauce
- 3 cloves garlic, minced
- 2 T olive oil
- Pinch of salt and pepper
- 3 T grated Parmesan cheese
- 8 oz fresh mozzarella cheese
- 8 oz cheddar cheese, grated

Directions:

1. In a bowl combine flour, sugar, yeast, and salt.
2. Add in warm water and oil and combine.
3. Scrape the dough out of the bowl onto a floured surface and knead the dough until it becomes tacky.
4. Add dough back into bowl and cover and set in a warm place.
5. Allow the dough to rise for about 1 hour and 30 minutes or until doubled in size.
6. Once dough has doubled, on a floured surface roll out your dough and form into a round crust.
7. Begin to assemble your pizza and preheat a pizza stone in your Bravo at 400°F and heat your stone.
8. Brush olive oil onto your dough then spread on tomato sauce. Evenly spread garlic, and then sprinkle on cheese. Finish with salt and pepper.
9. Gently slide your pizza onto the heated pizza stone and set your Bravo to "Pizza" with the Cooking Rack and stone on the lowest setting.
10. Cook for 15-18 minutes at 375°F.
11. Once finished use a pizza peel to remove pizza from stone and let rest for 3-4 minutes.
12. Slice, serve, and enjoy.

Dehydrate

nuwave
LIVE WELL FOR LESS



Beef Jerky

Serves: 20

Ingredients:

- 1 lbs Flank Steak, Sliced into strips
- ½ C soy sauce
- Pinch of salt and pepper
- 1 ½ T liquid smoke
- 1 T garlic powder

Directions:

1. In a bowl combine all your ingredients, then add in steak and coat steak with your marinade. Place into a bag and store in the fridge overnight.
2. Lay out the beef strips in your Air Fry Basket and place onto the Cooking Rack in the middle position.
3. Set the Bravo to "Dehydrate" at 170°F for 4 hours.
4. Once finished carefully remove the jerky from the oven and let cool for 10 minutes.
5. Store in a sealable container and refrigerate for up to 1 month.



Banana Chips

Serves: 12

Ingredients:

2 bananas, sliced into rounds

Directions:

1. Lay bananas out into your Air Fry Basket.
2. Place into your Bravo on the Cooking Rack set on the middle position.
3. Set your Bravo to "Dehydrate" at 200°F for 1 hour and 30 minutes.
4. Once finished carefully remove from oven and let cool 5 minutes.



Candied Bacon

Serves: 6

Ingredients:

- 12 slices of bacon
- 1/3 C brown sugar
- 4 T maple syrup
- Pinch of black pepper

Directions:

1. Season bacon with brown sugar and pepper.
2. Lay strips onto Baking Pan and top with maple syrup.
3. Place Baking Pan onto Cooking Rack set on the middle position.
4. Set your Bravo to "Dehydrate" on 150°F for 1 hour and 15 minutes.
5. Once finished carefully remove from the oven and let cool. Serve and enjoy.



Croutons

Serves: 8

Ingredients:

1 loaf day old bread (sourdough, challah, etc.), Cubed

$\frac{1}{3}$ C olive oil

Pinch of salt and pepper

2 T herbs de provance

Directions:

1. In a bowl combine bread, olive oil, salt, pepper, and herbs.
2. Lay out the bread onto the Baking Pan.
3. Place Pan into the Bravo on your Cooking Rack set in the lowest position.
4. Set the Bravo to "Dehydrate" at 375°F for 15 minutes.
5. Once finished carefully remove from the oven and let cool for 5 minutes.
6. Serve on top of a salad and enjoy.



Sun-dried Tomato

Serves: 2

Ingredients:

- 2 lb roma tomatoes, halved
- Pinch of salt and pepper
- 1/3 C olive oil
- 2 sprigs rosemary

Directions:

1. Toss your tomatoes in olive oil and season with salt and pepper.
2. Sprinkle rosemary over the tops and lay on a Baking Pan.
3. Place Baking Pan onto the Cooking Rack set on the middle position.
4. Set Bravo to "Dehydrate" on 200°F for 8 hours.
5. Once finished carefully remove from the oven and let cool. Serve and enjoy.



Dried Apricots

Serves: 12

Ingredients:

10 apricots, pitted and sliced
1 T lemon juice

Directions:

1. Soak apricots for 10 minutes then drain and blot dry.
2. Mix apricots with lemon juice and lay them out onto your Air Fry Basket.
3. Place basket onto your Cooking Rack set on the middle position.
4. Set Bravo to "Dehydrate" at 200°F for 10 hours.
5. Once finished carefully remove from the oven and let cool.

Baking



nuwave
LIVE WELL FOR LESS



Buttery Dinner Rolls

Serves: 12

Ingredients:

1 pack active dry yeast
¼ C water
⅓ T sugar
1 ½ C milk
4 C flour
6 T butter, softened

4 T sugar
1 T salt
Pinch of pepper

Directions:

1. In a bowl dissolve the yeast in warm water with sugar, let sit for 5 minutes.
2. Heat the milk and add in sugar and butter. Once mixture is cool add in yeast.
3. Add in 2 C of flour and mix until it makes a batter. Cover and let dough rise for 1 hour in a warm place.
4. Uncover and add 2 C flour and salt and knead for 5 minutes.
5. Place dough into a greased bowl and cover it and let it rise for 30 minutes in a warm place.
6. Remove dough from the bowl and work into 12 rolls.
7. Grease your Baking Pan and place rolls onto the pan.
8. Place the Baking Pan onto the Cooking Rack in the lowest position and set your Bravo to "Bake" for 20 minutes at 275°F.
9. Once your rolls have baked for 20 minutes remove and let cool.
10. At this point you may take these "pre-baked" rolls and store them once cooled, if not you can bake them for an extra 10 minutes at 400°F. Serve and enjoy.



Italian Loaf

Serves: 1

Ingredients:

- 1 pack active dry yeast
- 1 t sugar
- 3 C bread flour
- 2 T olive oil
- Pinch of salt

Directions:

1. In a bowl combine yeast and sugar in warm water and let sit for 5 minutes.
2. Add flour, salt, and oil and mix until it forms a soft dough.
3. Place dough into a greased bowl, cover and let sit for 45 minutes in a warm place.
4. Once dough has proofed, remove it from the bowl and knead on a floured surface.
5. Form dough into a loaf and place onto your Baking Pan.
6. Cut slits into the top of your loaf (3-4 slits) and place Baking Pan on Cooking Rack at the lowest position in your Bravo.
7. Set your Bravo to "Bake" and bake your bread for 17 minutes at 400°F.
8. Let bread cool for 5 minutes, serve and enjoy.



Frutti di Bosco

Serves: 8

Ingredients:

$\frac{2}{3}$ C butter, melted

1 $\frac{1}{4}$ C sugar

8 large eggs, separated

$\frac{1}{2}$ lemon, zested

1 t cinnamon

$\frac{1}{4}$ t salt

2 $\frac{1}{2}$ C flour, sifted

4 $\frac{1}{2}$ C mixed berries (blueberries, strawberries, raspberries)

Directions:

1. Grease an 11 inch springform pan.
2. In a mixer, Cream butter and sugar in a large mixing bowl. Add egg yolks, one at a time, and continue mixing until smooth. Add lemon zest and cinnamon.
3. In a separate bowl, whip egg whites and salt until stiff peaks form.
4. Gently fold egg whites into yolk mixture.
5. Fold flour into mixture until blended.
6. Pour mixture into pan and spread evenly.
7. Top with 3 cups of mix berries and press into your mixture.
8. Set Bravo to "Bake" at 350°F for 45 minutes and place Cooking Rack on the lowest position.
9. Once finished remove from oven and let cool for 15 minutes.
10. Top with remaining fruit. Serve and enjoy.

Dessert



nuwave
LIVE WELL FOR LESS



Bread Pudding

Serves: 6

Ingredients:

- 1 loaf day old bread, cubed
- 5 eggs
- 1 C sugar
- 3 C heavy cream
- 2 t vanilla extract
- 1 t cinnamon

Directions:

1. In a bowl whisk together eggs, heavy cream, vanilla, cinnamon, and sugar.
2. Place bread into a greased Baking Pan and pour egg mixture over the bread.
3. Allow bread to soak up the mixture for about 10 minutes.
4. Place Baking Pan onto the Cooking Rack on the lowest position.
5. Set Bravo to 350°F for 40 minutes.
6. Once finished carefully remove from the oven and let cool for 5 minutes.
7. Cut, serve, and enjoy.



Homestyle Peach Cobbler

Serves: 4

Ingredients:

- 4 T butter
- 1 C flour
- 2 C sugar, divided
- 1 T baking powder
- ½ C milk
- 4 Peaches, sliced

Directions:

1. In a bowl combine flour, 1 cup sugar, and baking powder, add milk and stir.
2. Pour batter into a greased Baking Pan.
3. In a pot bring 1 cup sugar, and sliced peaches to a slow boil, constantly stir, then pour over your batter.
4. Place Baking Pan onto Cooking Rack set at the lowest position.
5. Set Bravo to "Bake" at 375°F for 40 minutes.
6. Once finished carefully remove from the oven and let cool for 5 minutes, serve and enjoy.



Chocolate Chunk Cookies

Serves: 12

Ingredients:

- 2 ½ C flour
- 1 t baking soda
- 1 ½ t cornstarch
- ½ C sugar
- ½ t salt
- ¾ C butter, melted
- ¾ C brown sugar
- 1 egg
- 1 t vanilla
- 1 C chocolate chips

Directions:

1. In a bowl combine flour, baking soda, cornstarch, and salt.
2. In a separate bowl combine butter, brown sugar, and sugar.
3. Combine your wet and dry ingredients and stir to make a soft dough.
4. Fold in your chocolate chips and cover in the fridge for up to 3 hours.
5. Remove from the fridge and spoon dough into and roll into balls and lay out onto a greased Baking Pan and set onto the Cooking Rack on the lowest position.
6. Set your Bravo to "Bake" at 350°F for 12 minutes.
7. Once finished carefully remove the Baking Pan and let cookies cool for 10 minutes. Serve and enjoy.

nuwave®
— LIVE WELL FOR LESS —

NuWave Bravo™

Horno Inteligente



Manual del Usuario y Recetario Completo

12 Menús Preprogramados

Freir con Aire <ul style="list-style-type: none">• Temperatura Predeterminada: 360°F• Tiempo Predeterminado: 15 minutos• Fuente de Calor: Ventilador Alto (Nivel 3)• Posición de la Rejilla: Posición 1, 2 ó 3	Asar <ul style="list-style-type: none">• Temperatura Predeterminada: 500°F• Tiempo Predeterminado: 10 minutos• Fuente de Calor: Superior (100 por ciento)• Posición de Rack: Posición 1 ó 2
Recalentar <ul style="list-style-type: none">• Temperatura Predeterminada: 350°F• Tiempo Predeterminado: 10 minutos• Fuente de Calor: Superior/Inferior (100/100 por ciento)• Posición de la Rejilla: Cualquier Posición	Congelado <ul style="list-style-type: none">• Temperatura Predeterminada: 325°F• Tiempo Predeterminado: 20 minutos• Fuente de Calor: Superior/Inferior (100/100 por ciento)• Posición de la Rejilla: La posición depende del resultado deseado.
Waffle <ul style="list-style-type: none">• Temperatura Predeterminada: 400°F• Tiempo Predeterminado: 4 minutos• Fuente de Calor: Superior/Inferior (100/100 por ciento)• Posición de la Rejilla: Posición 2 ó 3	A la Parrilla <ul style="list-style-type: none">• Temperatura Predeterminada: 400°F• Tiempo Predeterminado: 15 minutos• Fuente de Calor: Parte Inferior (100 por ciento)• Tendrá un Precalentamiento• Posición de la Rejilla: Posición 1
Hornear <ul style="list-style-type: none">• Temperatura Predeterminada: 350°F• Tiempo Predeterminado: 25 minutos• Fuente de Calor: Superior/Inferior (100/100 por ciento)• Tendrá un Precalentamiento• Posición de la Rejilla: Posición 2 ó 3	Deshidratar <ul style="list-style-type: none">• Temperatura Predeterminada: 100°F• Tiempo Predeterminado: 2 horas• Fuente de Calor: Ventilador Bajo (Nivel 1)• Posición de la Rejilla: la posición depende del resultado deseado.
Rostizar <ul style="list-style-type: none">• Temperatura Predeterminada: 310°F• Tiempo Predeterminado: 25 minutos• Fuente de Calor: Superior/Inferior (100/100 por ciento)• Tendrá un Precalentamiento• Posición de la Rejilla: Posición 1	Tostar <ul style="list-style-type: none">• Temperatura Predeterminada: 310°F• Tiempo Predeterminado: 3 minutos• Fuente de Calor: Superior/Inferior (100/100 por ciento)• Posición de la Rejilla: Posición 2, 3 ó 4
Pizza <ul style="list-style-type: none">• Temperatura Predeterminada: 450°F• Tiempo Predeterminado: 15 minutos• Fuente de Calor: Superior/Inferior (100/100 por ciento)• Tendrá un Precalentamiento• Posición de la Rejilla: Posición 2 ó 3• NOTA: Los tiempos y temperaturas variarán según el tamaño de la pizza.	Bagel <ul style="list-style-type: none">• Temperatura Predeterminada: 310°F• Tiempo Predeterminado: 3 minutos• Fuente de Calor: Superior/Inferior (100/100 por ciento)• Posición de la Rejilla: Posición 2, 3 ó 4

NOTA:

- NUNCA permita que ningún alimento toque los elementos de calor directamente.
- Las temperaturas, los tiempos y las posiciones de la rejilla predeterminados son una guía. Es posible que sea necesario realizar ajustes para alcanzar el resultado deseado.
- La velocidad del ventilador es Alta (nivel 3) a menos que se ajuste la velocidad. Deshidratar debe ser la configuración de ventilador más baja (nivel 1).

Tabla de Medidas		
Cucharadita = t	Fahrenheit = °F	Minuto = min
Cucharada = T	Centígrados = °C	Segundo = sec
Taza = C	Onzas líquidas = fl oz	Pulgada = in.
Onza = oz	Litro = L	Docena = doz
Libra (s) = lb(s)	Mililitro = ml	Hora = hr
Cuarto = qt	Paquete = pkg.	Gramo = g
Pinta = pt	Galón = gal	

MEDIDAS DE SEGURIDAD IMPORTANTES

LEE TODAS LAS INSTRUCCIONES

ADVERTENCIA: Cuando se use el Horno Inteligente Bravo, siempre se deben seguir medidas de seguridad básicas:

1. No toque las superficies calientes. Use las agarraderas y guantes para horno cuando retire alimentos del Bravo.
2. Para protegerse contra el riesgo de descarga eléctrica, no sumerja el cable, el enchufe o cualquier parte de la unidad principal del Bravo en agua u otros líquidos o cuando sus manos estén mojadas.
3. No limpie con fibras de metal.
4. No utilice el Bravo con un cable o enchufe dañado. Si el electrodoméstico no funciona bien, se cae o se daña de cualquier manera. Comuníquese con Servicio al cliente al 1-877-689-2838 o envíe un correo electrónico a help@nuwavenow.com para obtener información sobre el examen y la reparación o ajuste.
5. Es necesaria una supervisión estricta cuando cualquier dispositivo es utilizado cerca de niños. El Bravo no está diseñado para ser utilizado por niños, personas con capacidades físicas, sensoriales o mentales reducidas, o aquellos con falta de experiencia o conocimiento de esta unidad.
6. No permita que el cable cuelgue del borde de la mesa o mostrador.
7. No permita que el cable entre en contacto con superficies calientes, incluida la parte superior de la estufa.
8. Coloque el Bravo en una superficie que sea horizontal, pareja y estable.
9. No lo coloque sobre o cerca de un quemador de gas o eléctrico caliente o en un horno caliente.
10. No coloque la unidad cerca de materiales inflamables, unidades de calefacción, o ambientes húmedos.
11. No coloque recipientes herméticos en el Bravo.
12. No coloque recipientes hechos de plástico o caucho en la unidad. Evite utilizar recipientes hechos de cualquier otro material que no sea cerámica, vidrio o metal en la unidad.
13. No coloque papel, cartón, plástico ni ningún otro material inflamable en el Bravo durante su uso.
14. No modifique ninguna parte del Bravo, ni use accesorios no recomendados por el fabricante.
15. Si durante el funcionamiento escapa humo en exceso de la ventilación, desenchufe inmediatamente y comuníquese con Servicio al Cliente al 1-877-689-2838 o envíe un correo electrónico a help@nuwavenow.com.
16. No llene demasiado el Bravo de manera que el contenido toque los elementos de calor o bloquee el ventilador.
17. Durante el uso, puede salir vapor de las salidas de aire. Mantenga las manos y la cara lejos de las aberturas de salida de aire. Tenga cuidado con el vapor caliente que se escapa al abrir el Bravo.
18. Evite colocar la cara y los ojos cerca de la puerta de vidrio durante el uso.

MEDIDAS DE SEGURIDAD IMPORTANTES (Continuación)

19. Nunca toque el interior del Bravo mientras está en funcionamiento.
20. Nunca deje el Bravo desatendido durante el uso.
21. El Bravo está diseñado para uso doméstico normal. No está diseñado para ser utilizado en entornos tales como cocinas de personal, tiendas, oficinas u otros entornos de trabajo. No es apto para el uso al aire libre.
22. No use el Bravo para otra cosa que no sea su uso previsto.
23. Nunca coloque el Bravo contra la pared u otros electrodomésticos. Debe haber al menos 5 pulgadas de espacio libre detrás, a los lados y encima del Bravo.
24. No desmonte la unidad.
25. No coloque en el Bravo utensilios de cocina o platos que no sean aptos para el horno.
26. Desenchufe el Bravo de la toma de corriente cuando no esté en uso o antes de limpiarlo.
27. Permita que el Bravo se enfríe antes de ponerle o quitarle partes o antes de limpiarlo.
28. No use este horno junto con otro aparato eléctrico con alta potencia, en caso de sobrecarga.
29. Use siempre guantes protectores y aislantes para el horno cuando inserte o retire artículos del horno caliente.
30. No cubra ninguna parte del horno con papel de aluminio.
31. Utilice papel de aluminio para envolver la comida que producirá aceite o jugo cuando esté en funcionamiento y colóquela en la bandeja de hornear, en caso de incendio.
32. Asegúrese de que el papel de estaño no esté conectado con los elementos de calentamiento, en caso de incendio.
33. No cubra la bandeja para migas ni ninguna parte del horno con papel de aluminio. Esto causará el sobrecalentamiento del horno.



ADVERTENCIA

En caso de otros problemas, desenchufe la unidad y contacte a Servicio al Cliente al 1-877-689-2838 o envíe un correo electrónico a help@nuwavenow.com.

MEDIDAS DE SEGURIDAD ADICIONALES

VER CUIDADO Y MANTENIMIENTO ANTES DEL USO

Información eléctrica

El Horno Inteligente Bravo incluye un cable de alimentación corto para reducir el riesgo de enredos o tropiezos. Se pueden usar cables de extensión si se tiene cuidado en su uso. Si se usa un cable de extensión:

1. La clasificación eléctrica marcada del cable de extensión debe ser al menos tan buena como la clasificación eléctrica del Bravo.
2. El cable más largo debe colocarse de modo que no cuelgue sobre la encimera o sobre la mesa donde los niños puedan tirar de él o tropezarse involuntariamente. El Bravo se debe operar en una toma de corriente separada de otros aparatos debido a limitaciones de voltaje. Ciertos modelos de los dispositivos pueden tener un enchufe polarizado (una clavija es más ancha que la otra). Para reducir el riesgo de una descarga eléctrica, este enchufe está diseñado para encajar en una toma polarizada en una dirección. Si el enchufe no encaja completamente en la toma de corriente, invierta el enchufe. Si el enchufe todavía no se ajusta correctamente, contacte a un electricista calificado. No intente modificar el enchufe de ninguna manera.

GUARDE ESTAS INSTRUCCIONES:

Lea y comprenda todo el manual antes de usar este electrodoméstico.

1. La cantidad de ingredientes colocados en Bravo debe cumplir con las instrucciones enumeradas en "Instrucciones de Funcionamiento".
2. No mueva la unidad mientras está en funcionamiento.
3. Sólo después de que el Bravo se haya enfriado por completo, debe intentar moverlo o manejarlo.
4. NO intente utilizar el Bravo para freír alimentos ya que NO es su uso previsto y puede crear un riesgo de incendio.
5. No cubra los respiraderos de recepción de aire ni los orificios de escape mientras el Bravo esté en funcionamiento.
6. Siempre coloque los ingredientes para cocinar en la Bandeja para Hornear apropiada (no llene en exceso) y no permita que los alimentos entren en contacto directo con los componentes de calor.
7. Asegúrese de que el Bravo esté siempre limpio antes de cocinar.
8. Es normal que escape un poco de humo de la unidad cuando se calienta por primera vez.

MEDIDAS DE SEGURIDAD ADICIONALES (Continuación)

9. Antes de quitar el enchufe de la toma de corriente, siempre apague la unidad.
10. Desenchufe siempre el cable de alimentación tirando de la clavija, NO del cable.

AVISO: EL NO SEGUIR CUALQUIERA DE LAS MEDIDAS DE SEGURIDAD IMPORTANTES, MEDIDAS DE SEGURIDAD ADICIONALES O LAS INSTRUCCIONES PARA UN USO SEGURO, SE CONSIDERA UN MAL USO DEL HORNO INTELIGENTE BRAVO, LO CUAL PUEDE ANULAR LA GARANTÍA Y CREAR EL RIESGO DE LESIONES GRAVES.



ADVERTENCIA

Nunca use el Bravo con partes sueltas, dañadas o faltantes.

DESCRIPCIÓN DE PARTES

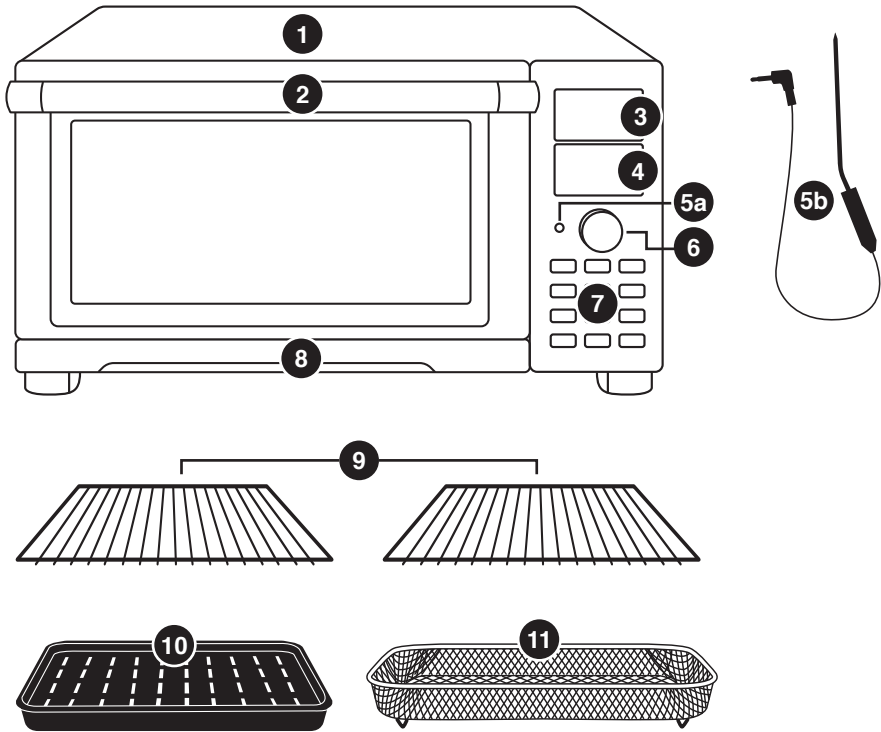

- 1** Base
- 2** Manija
- 3** Menú de Pantalla Digital
- 4** Menú
- 5a** Entrada de Sensor
- 5b** Sensor de Temperatura
Parte #: 26808
- 6** Perilla
- 7** Funciones
- 8** Bandeja para Migajas Removible
Parte #: 26801
- 9** 2 Rejillas de Cocina de Uso Rudo
Parte #: 26802
- 10** Bandeja Esmaltada para Horno y Rejilla Esmaltada para Asar
Parte #: 26804
- 11** Canastilla De Freír
Parte #: 26816
- 12** Luz del Horno
Parte #: 26807

GUÍA DE MONTAJE

1. Coloque el Bravo en una superficie plana, nivelada, estable y resistente al calor.
2. Coloque la(s) Rejilla(s) de Cocción ya sea en la posición 1, 2, 3 ó 4 del Bravo.
3. Coloque la Bandeja para Hornear con la Rejilla para Asar en la Rejilla de Cocina en la posición 1.
4. Coloque la Canastilla para Freír encima de la Bandeja para Hornear. Se recomienda utilizar la Canastilla para Freír y la Bandeja para Hornear para optimizar los resultados de cocción.
5. Coloque la Bandeja para Migajas en su lugar deslizándola en la ranura en la parte inferior del horno. Para quitarla, empuje hacia abajo levemente y sáquela.
6. Conecte el aparato a una toma de corriente estándar. El enchufe de alimentación está ubicado en la parte posterior de la unidad.

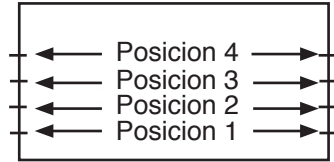

NOTA: No cubra ni bloquee las rejillas de ventilación de entrada ubicadas en la parte posterior y los laterales del Bravo, ya que esto puede evitar una ventilación adecuada.

INSTRUCCIONES DE FUNCIONAMIENTO

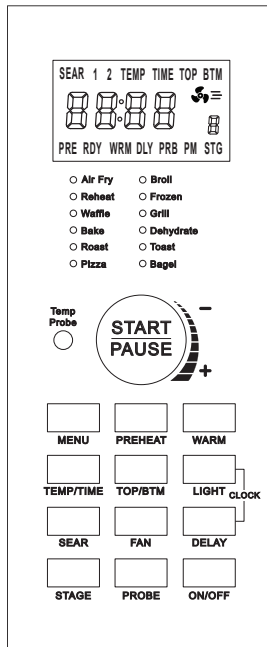

INSTRUCCIONES DE FUNCIONAMIENTO (Continuación)

ON/OFF y START/PAUSE:

1. Presione "ON/OFF" una vez para encender el Bravo. La unidad emitirá un pitido y la pantalla LED mostrará "350F" (predeterminado), TEMP, TOP, BTM y El ícono del ventilador se mostrará fijo.
2. Presione "START/PAUSE" para comenzar a cocinar. La unidad cocinará a 350°F por 10 minutos. Esta es la configuración predeterminada.
 - La pantalla LED mostrará "00:10" y comenzará una cuenta regresiva. TIME, TOP, BTM y el icono del ventilador estarán retroiluminados con el icono ":" parpadeando.
 - Para ajustar la temperatura de cocción, gire la perilla "START/PAUSE" hacia "+" (en sentido de las manecillas del reloj) para aumentar o hacia "-" (en sentido contrario) para disminuir la temperatura en incrementos de 5°F. Gire rápidamente la perilla para ajustar en incrementos más grandes.
 - Para ajustar el tiempo de cocción, presione "TEMP/TIME". La pantalla LED mostrará "00:10", TIME, TOP, BTM y el ícono del ventilador será sólido. Gire la perilla "START/PAUSE" hacia "+" (en sentido de las manecillas del reloj) para aumentar o hacia "-" (en sentido contrario) para disminuir el tiempo en incrementos de 1 minuto. Gire rápidamente la perilla para ajustar en incrementos más grandes.
 - Presione "TEMP/TIME" para cambiar la visualización de la pantalla LED entre la temperatura de cocción actual y la hora.
3. Presione "START/PAUSE" una vez durante la cocción para pausar.
 - Si la pantalla LED muestra el tiempo de cocción cuando en pause, mostrará el tiempo restante, HORA, y ":" todo fijo.
 - Si la pantalla LED muestra la temperatura de cocción, mostrará la temperatura de cocción (por ejemplo, 360 ° F), TEMP, TOP, BTM y el ícono de ventilador completamente fijos.
 - Durante la pausa, solo funcionarán los botones "START / PAUSE", "ON / OFF" y "LIGHT".
4. Presione "START/PAUSE" por segunda vez para reanudar la cocción. Todos los símbolos en la pantalla LED estarán fijos.
 - La pantalla LED mostrará el tiempo de cocción restante y continuará la cuenta regresiva. TIME, TOP, BTM y el icono del ventilador estarán retroiluminados con ":" parpadeando.
 - Tanto la temperatura de cocción como el tiempo se pueden ajustar durante la cocción simplemente pulsando "TEMP/TIME" y luego girando la perilla "START/PAUSE" para ajustar.

INSTRUCCIONES DE FUNCIONAMIENTO (Continuación)

RELOJ:

1. Configuración del Reloj:
 - Presione "LIGHT" y "DELAY" al mismo tiempo. La pantalla LED mostrará "00:00" y ":" parpadeará.
 - Gire la perilla "START/PAUSE" para configurar el Reloj. Cuando la pantalla LED llegue a "12:00", PM estará retroiluminado.
2. Visualización del Reloj durante la cocción:
 - Presione "LIGHT" y "DELAY" al mismo tiempo. La pantalla LED mostrará la hora actual.
 - El tiempo se puede ajustar en este momento.
 - La hora del Reloj permanecerá en la pantalla LED hasta que se presione el botón "START/PAUSE" o cualquier otro botón.

LUZ:

Predeterminado-Luz Apagada.

1. Presione "LIGHT" una vez para encender la luz.
2. Presione "LIGHT" por segunda vez para apagar la luz.

VENTILADOR:

Predeterminado-Nivel 3, Velocidad Máxima

1. Presione "FAN", la pantalla LED mostrará "3" arriba de STG y el ícono FAN sera fijo.
 - Presionar "FAN" también cambiará la velocidad del ventilador.
 - La velocidad del ventilador se puede ajustar durante la cocción presionando simplemente "FAN".
2. Para apagar el ventilador, presione "FAN" hasta que el icono FAN ya no esté nuevamente iluminado. Esto indica que el ventilador ya no se está ejecutando.
3. Nivel de velocidad del ventilador:
 - Nivel 1 - 33.33% de velocidad
 - Nivel 2 - 66.67% de velocidad
 - Nivel 3 - 100% de velocidad

SUPERIOR/INFERIOR:

Predeterminado: superior 100%, inferior 100%. Esto se refiere a la cantidad de calor proveniente de los elementos de calor superior e inferior.

1. Presione "ON/OFF".
2. Presione "TOP/BTM", la pantalla LED mostrará "100" y TOP fijo. Ajuste la cantidad de calor proveniente de los elementos de calor superior girando la perilla "START / PAUSE". El porcentaje cambiará en incrementos del 10%.
3. Presione "TOP/BTM" nuevamente, la pantalla LED mostrará "100" y BTM solido. De nuevo, ajuste el calor con "START/PAUSE".
4. Cuando se elijan los calentadores superior e inferior, presione "START/PAUSE". El Bravo cocinará a la potencia programada.

INSTRUCCIONES DE FUNCIONAMIENTO (Continuación)

NOTA: Al utilizar la función de Menú "Broil", la potencia BTM no es ajustable ya que la función Broil solo utiliza los elementos superiores de calentamiento.

TEMPERATURA/TIEMPO:

Predeterminado - 350° F, 10 minutos

1. Presione "TEMP/TIME" una vez, la pantalla LED mostrará "00:10" y TIME. Presione "START / PAUSE" para comenzar a cocinar.
 - Gire la perilla "START/PAUSE" hacia "+" (hacia la derecha) para aumentar el tiempo en incrementos de 1 minuto. Gire rápidamente el dial para ajustar en incrementos más grandes.
 - Gire la perilla "START/PAUSE" hacia "-" (en sentido contrario a las manecillas del reloj) para disminuir el tiempo en incrementos de 1 minuto.
 - Gire rápidamente la perilla para ajustar en incrementos más grandes.
2. Presione "TEMP/TIME" nuevamente, la pantalla LED mostrará "350F" y TEMP. Presione "START / PAUSE" para comenzar a cocinar.
 - Gire la perilla "START/PAUSE" hacia "+" (hacia la derecha) para aumentar la temperatura en incrementos de 5°F. Gire rápidamente el dial para ajustar en incrementos más grandes.
 - Gire la perilla "START/PAUSE" hacia "-" (en sentido contrario a las manecillas del reloj) para disminuir la temperatura en incrementos de 5°F.
 - Gire rápidamente el dial para ajustar en incrementos más grandes.
3. Presione "START/PAUSE" para comenzar a cocinar.
4. El Bravo emitirá un pitido 3 veces y la pantalla LED mostrará "End" cuando la cocción haya finalizado.

NOTA:

- Se puede presionar "TEMP/TIME" para ver la temperatura de cocción actual y el tiempo de cocción restante actual.
- La perilla "START/PAUSE" puede girarse, junto con presionar "TEMP/TIME", para cambiar la temperatura y el tiempo de cocción durante la cocción.
- El rango de tiempo de cocción para 100F-395F es de 00:00 a 99:59 y 400F-450F de 00:00 a 01:00

PRECALENTAR:

1. Presiona "ON / OFF". Ajuste la temperatura de cocción y el tiempo de cocción.
 - Gire la perilla "START / PAUSE" hacia "+" (hacia la derecha) para aumentar la temperatura en incrementos de 5 ° F. Gire rápidamente el dial para ajustar en incrementos más grandes.
 - Gire la perilla "START / PAUSE" hacia "-" (en sentido antihorario) para disminuir la temperatura en incrementos de 5 ° F. Gire rápidamente el dial para ajustar en incrementos más grandes.
2. Presiona "PREHEAT". La pantalla LED mostrará la temperatura de cocción

INSTRUCCIONES DE FUNCIONAMIENTO (Continuación)

ajustada y TEMP será fijo.

3. Presione "START / PAUSE" para comenzar el precalentamiento.
 - Durante el precalentamiento, la pantalla LED mostrará la temperatura seleccionada parpadeando junto con el ícono FAN, TEMP, TOP, BTM & PRE.
 - Cuando se alcanza la temperatura de precalentamiento, la pantalla LED mostrará "5" TOP y BTM se mantendrá estable y comenzará una cuenta regresiva de 5 minutos. RDY estará retroiluminado.
 - El Bravo emitirá un pitido para indicar que el horno ha alcanzado la temperatura de precalentamiento y los alimentos están listos para colocarse en el horno.
 - Coloque con cuidado los alimentos en el Bravo y presione "INICIAR / PAUSAR" para comenzar a cocinar.
 - Si no se presiona "INICIO / PAUSA" dentro de la cuenta regresiva de 5 minutos, el Bravo se apagará automáticamente y mostrará la Hora del reloj.

NOTA: El tiempo de cocción y la temperatura de cocción no se pueden ajustar durante el tiempo de retención de 5 minutos después de alcanzar la temperatura de precalentamiento.

DEMORAR:

Predeterminado 1 hora.

1. Presione "DELAY", se mostrará "01:00", TIME y DLY en la pantalla LED.
 - Ajuste el tiempo de demora girando la perilla START/PAUSE hacia "+" (en sentido de las manecillas del reloj) para aumentar el tiempo en incrementos de 1 minuto o girando la perilla "START/PAUSE" hacia "-" (en sentido opuesto a las manecillas del reloj) para disminuir el tiempo en incrementos de 1 minuto.
 - Gire rápidamente la perilla para ajustar en incrementos más grandes.
 - El tiempo máximo de demora es 99 horas, 59 minutos (99:59).
2. Presione "START/PAUSE" para comenzar la cuenta regresiva del tiempo.
 - El tiempo de demora establecido se mostrará con una cuenta regresiva.
 - TIME se mostrarán fijo en la pantalla LED durante la cuenta regresiva del tiempo restante. DLY y ":" parpadeará durante la cuenta regresiva del tiempo de demora.
3. Una vez que se complete la cuenta regresiva de la demora, el Bravo comenzará a cocinar a la temperatura y tiempo de cocción establecidos (el valor predeterminado es 350°F durante 10 minutos).

Usando DEMORA con la función de cocción:

Ejemplo #1: Deje cocinar 40 minutos, cocine a 360°F durante 20 minutos.

- Presione "DELAY", ajuste el tiempo a 40 minutos (00:40).
- Presione "TEMP/TIME" para ajustar la temperatura de cocción. Ajuste la

INSTRUCCIONES DE FUNCIONAMIENTO (Continuación)

temperatura a 360°F (360°F).

- Presione "TEMP/TIME" por segunda vez y ajuste el tiempo a 20 minutos (00:20).
- Presione "START/PAUSE". El Bravo esperará 40 minutos, luego comenzará cocinar a 360°F por 20 minutos.

Ejemplo #2: Deje cocinar por 60 minutos, cocine a 400°F por 10 minutos.

- Presione "DELAY", ajuste el tiempo a 1 hora (01:00).
- Presione "TEMP/TIME" para ajustar la temperatura de cocción. Ajuste la temperatura a 400°F (400°F)
- Presione "TEMP/TIME" por segunda vez y ajuste el tiempo a 10 minutos (00:10).
- Presione "START/PAUSE". El Bravo esperará 60 minutos, luego comenzará a cocinar a 400°F por 10 minutos.

NOTA:

- Demora siempre será la primera función ejecutada por Bravo.
- El Bravo emitirá un pitido 3 veces y la pantalla LED mostrará "End" cuando la cocción haya finalizado.

FUNCIONES DEL MENÚ PRE-PROGRAMADO:

1. Presione "ON/OFF".
2. Presione "MENÚ". La pantalla LED mostrará "360F" (predeterminado) y la luz LED al lado de "Air Fry" se encenderá y TEMP, TOP, BTM, y el icono del ventilador serán fijos.
3. Presione "MENÚ" para elegir el menú deseado. La pantalla LED cambiará según el menú seleccionado.
4. Para cambiar la selección del menú, presione "MENÚ" hasta que se seleccione el menú deseado.
5. Una vez que haya elegido el menú deseado, presione "START/PAUSE" para comenzar a cocinar. El tiempo de cocción se mostrará en la pantalla LED.
6. El Bravo emitirá un pitido 3 veces y la pantalla LED mostrará "End" cuando la cocción haya finalizado.

NOTA:

- Algunas funciones del menú requieren un paso de precalentamiento. Este paso está preprogramado en todas las funciones que lo requieren. Las funciones de precalentamiento son "Bake", "Grill", "Pizza" y "Asar".
- Una vez que se alcanza la temperatura de precalentamiento, el Bravo emitirá un pitido y la pantalla LED mostrará "5" y comenzará una cuenta regresiva de 5 minutos.
- Si no se presiona ningún botón o la perilla de "START/PAUSE" no se marca en 5 minutos, la unidad se apagará automáticamente y se mostrará la Hora del reloj.

INSTRUCCIONES DE FUNCIONAMIENTO (Continuación)

SELLAR:

Predeterminado - 450°F, 5 minutos.

Sear 1: Sear 1 SIEMPRE será la etapa ANTES de la etapa de cocción regular.

1. Presione "ON/OFF".
2. Presione "SEAR" una vez, la pantalla LED mostrará "450F", TEMP y SEAR estarán retroiluminados y 1 parpadeará.
3. Presione "START/PAUSE". La pantalla LED mostrará SEAR 1 y ":" parpadeando. TIME, TOP y BTM estarán retroiluminados.
4. La unidad "sellará" a 450°F durante 5 minutos (SEAR 1) cocine a 350°F durante 10 minutos predeterminado) la unidad emitirá un pitido 3 veces y se mostrará "End" en la pantalla LED para indicar que la cocción está completa.

NOTA: La temperatura y el tiempo de la etapa de cocción regular se pueden ajustar girando la perilla "START/PAUSE" después del paso #1.

Sear 1 2: Predeterminado - 450°F, 5 minutos.

1. Presione "ON/OFF".
2. Presione "SEAR" dos veces, la pantalla LED mostrará "450F", TEMP y SEAR 1 estarán retroiluminados y 2 parpadearán.
3. Presione "START/PAUSE". la pantalla LED mostrará SEAR 1 y ":" parpadeando. TIME, TOP y BTM estarán retroiluminados.
4. La unidad cocinará a 450°F durante 5 minutos (SEAR 1) y "sellará" a 350°F durante 10 minutos (predeterminado), y "SEAR" otra vez a 450°F por 5 minutos (SEAR 2). SEAR 2 y ":" parpadearán. La unidad emitirá un pitido 3 veces y se mostrará "End" en la pantalla del LED indicando que la cocción está completa.

Sear 2: Predeterminado - 450°F, 5 minutos.

1. Presione "ON/OFF".
2. Presione "SEAR" tres veces, la pantalla LED mostrará "450F", TEMP y SEAR estarán retroiluminados y 2 parpadearán.
3. Presione "START/PAUSE".
4. La unidad cocinará a 350°F durante 10 minutos (predeterminado) y "sellará" a 450°F por 5 minutos (SEAR 2). La unidad emitirá un pitido 3 veces y se mostrará "End" en la pantalla del LED indicando que la cocción está completa.

NOTA:

- Presione "SEAR" tres veces para borrar la función de búsqueda.
- El tiempo máximo para todas las funciones de sellar es de 5 minutos.
- La temperatura máxima para todas las funciones de sellar es de 450°F.

INSTRUCCIONES DE FUNCIONAMIENTO (Continuación)

ETAPA: Se pueden programar un máximo de 5 etapas.

1. Presione "ON/OFF". La pantalla LED mostrará "350F".
2. Presione "STAGE".
 - La pantalla LED mostrará TEMP y se mostrará STG 2.
 - Presione "TEMP/TIME" y gire "START/PAUSE" para ajustar la temperatura y el tiempo de cocción de esta etapa.
3. Presione "STAGE" nuevamente para programar otra etapa de cocción.
 - La pantalla LED mostrará TEMP y STG parpadeando y se mostrará "3" arriba de STG.
 - Presione "TEMP/TIME" y gire "START/PAUSE" para ajustar la temperatura y el tiempo de cocción de esta etapa.
4. Se puede programar un máximo de 5 etapas.
5. Presione "START/PAUSE" para comenzar a cocinar siguiendo las etapas programadas.

CALENTAR, SELLAR 1, SELLAR 2, Y DEMORA CON LA COCCIÓN EN ETAPAS:

EJEMPLO: DEMORA durante 1 hora » SEAR 1 350°F durante 4 minutos » Cocine la etapa 1 a 325°F durante 20 minutos » cocine la etapa 2 a 300°F durante 40 minutos » cocine la etapa 3 a 350°F durante 10 minutos » SEAR 2 400°F por 5 minutos » CALENTAR a 125°F durante 30 minutos.

1. Presione "ON/OFF". Ajuste la temperatura a 325°F girando la perilla "START/PAUSE". La pantalla LED mostrará "325F" y TEMP. Presione "TEMP/TIME" y ajuste el tiempo a 20 minutos girando la perilla "START/PAUSE". La pantalla LED mostrará "00:20" y TIME.
2. Presione "DELAY" y ajuste el tiempo a 1 hora girando la perilla "START/PAUSE". La pantalla LED mostrará "01:00" y DLY y TIME.
3. Presione "SEAR" una vez y ajuste la temperatura a 350°F girando la perilla "START/PAUSE". Presione "TEMP/TIME" y ajuste el tiempo a 4 minutos girando la perilla "START/PAUSE". La pantalla LED mostrará "01:00", DLY, TIME, y SEAR. 1 parpadeara.
4. Presione "STAGE". Ajuste la temperatura a 300°F girando la perilla "START/PAUSE". Presione "TEMP/TIME" y ajuste el tiempo a 40 minutos girando la perilla "START/PAUSE". La pantalla LED mostrará STG 2 y "00:40", TIME, TOP, BTM, y el icono del ventilador.
5. Presione "STAGE" de nuevo. Ajuste la temperatura a 350°F girando la perilla "START/PAUSE". Presione "TEMP/TIME" y ajuste el tiempo a 10 minutos girando la perilla "START/PAUSE". La pantalla LED mostrará STG 3, "00:40", TIME, TOP, BTM y el icono del ventilador.
6. Presione "SEAR" nuevamente y ajuste la temperatura a 400°F girando la perilla "START/PAUSE". Presione "TEMP/TIME" y ajuste el tiempo a 5 minutos girando la perilla "START/PAUSE". La pantalla LED mostrará SEAR 1 y "00:05" y 2 y TIME.

INSTRUCCIONES DE FUNCIONAMIENTO (Continuación)

7. Presione "WARM" y ajuste la temperatura a 125°F girando la perilla "START/PAUSE". Presione "TEMP/TIME" y ajuste el tiempo a 30 minutos girando la perilla "START/PAUSE". La pantalla LED mostrará "00:30" y WRM y TIME.
8. Presione "START/PAUSE" para comenzar el proceso de cocción.

NOTA:

- Durante el cocinado, Bravo mostrará todas las funciones programadas para ese ciclo de cocción.
- La función en la que el Bravo esté cocinando actualmente parpadeará.
- El tiempo restante para esa función o etapa contará regresivamente y ":" parpadearán. Las funciones restantes para ese ciclo permanecerán retroiluminadas.
- A medida que cada función finaliza su cocción, los iconos dejarán de encenderse.

MANTENER CALIENTE:

Predeterminado 140°F, 1 hora.

1. Presione "ON/OFF". La pantalla LED mostrará "350F".
2. Presione "WARM". "140F" (predeterminado) aparecerá en la pantalla LED y TEMP & WRM serán fijos.
 - Ajuste la temperatura cálida girando la perilla "START/PAUSE" hacia "+" (en sentido de las manecillas del reloj) para aumentar o hacia "-" (en sentido contrario de las manecillas del reloj) para disminuir la temperatura en incrementos de 5°F. Gire rápidamente la perilla para ajustar en incrementos más grandes. El rango de temperatura es de 100°F-450°F.
 - Ajuste el tiempo de calentamiento girando la perilla "START/PAUSE" hacia "+" (hacia la derecha) para aumentar o hacia "-" (hacia la izquierda) para disminuir el tiempo en incrementos de 1 minuto. Gire rápidamente la perilla para ajustar en incrementos más grandes.
 - 100°F-395°F, tiempo seleccionable es 00:00 a 99:59.
 - 400°F-450°F, tiempo seleccionable es 00:00 a 99:59.
 - WRM aparecerá en la pantalla LED siempre que se use la función de Mantener Caliente.
3. Presione "START/PAUSE" para comenzar a cocinar.

NOTA: Mantener Caliente siempre será la última función de cocción ejecutada por el Bravo y el ventilador no girará durante esta función.

NOTA: El orden de la función de cocción es el siguiente:
PREHEAT » SEAR 1 » COOK » SEAR 2 » WARM » END

INSTRUCCIONES DE FUNCIONAMIENTO (Continuación)

SENSOR: Inserte la sonda de temperatura en la comida. Coloque los alimentos en el horno dejando suficiente del cable para salir del horno sobre la parte superior de la puerta. (ver diagrama). Inserte el conector de la sonda de temperatura en la entrada de la sonda.

Predeterminado 140°F, 10 minutos.

1. Presione "ON/OFF". Ajuste a la temperatura de cocción deseada.
2. Presione "PROBE". "140F" (predeterminado) aparecerá en la pantalla LED junto a TEMP & PRB.
 - Ajuste la temperatura a la temperatura de cocción interna deseada. El rango de temperatura es de 100°F-210°F. Ajuste el tiempo de cocción. El rango de tiempo es de 1 minuto a 99 horas, 59 minutos (00:01 - 99:59).

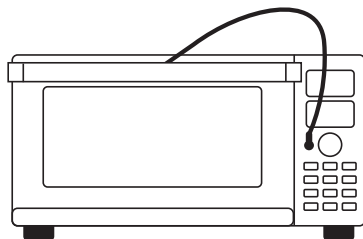

NOTA: El Bravo se cocinará hasta que se alcance la temperatura de la sonda. Si se acaba el tiempo antes de que se alcance la temperatura de la sonda, la unidad continuará cocinando hasta que se alcance la temperatura de la sonda.









3. Presione "START/PAUSE". La pantalla LED mostrará la temperatura actual de la sonda interna, TEMP, TOP, BTM y PRB.
 - Presione "TEMP/TIME" para visualizar la temperatura de cocción ajustada (predeterminado es 350°F).
 - Presione "PROBE" y "STAGE" juntos para visualizar la temperatura establecida del sensor. Esto se puede ajustar durante la cocción girando la perilla "START/PAUSE".
 - Presione "PROBE" para visualizar la temperatura actual del sensor interno.
4. Una vez que el sensor interno alcanza la temperatura establecida, el Bravo dejará de cocinar y se mostrará "End" en la pantalla LED.

NOTA:

- Cuando la sonda se desenchufa y se presiona "PROBE", se mostrará "Prob" (error) seguido de 3 pitidos cortos.
- Si la temperatura de cocción se configura y es menor de la temperatura configurada de la sonda, se mostrará "Prob" (error) seguido de 3 pitidos cortos una vez que el usuario presiona "START/PAUSE".
- Si no se alcanzó la temperatura de la sonda después de que el tiempo de cocción preestablecido haya finalizado, la unidad continuará cocinando. Mientras tanto, si el usuario presiona "TEMP/TIME" 2 veces para ver el tiempo de cocción restante, se mostrará "00:00" y permanecerá en "00:00" para indicar que el tiempo de cocción preestablecido se ha agotado.
- Para cancelar cualquier función o etapa durante el ciclo de cocción, simplemente pulse "TEMP/TIME" (si no está en la cuenta regresiva) y gire "START/PAUSE" hasta que el tiempo se lea como "00:00". Esto detendrá la función y se moverá a la próxima función en el ciclo de cocción.

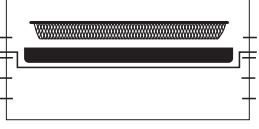
INSTRUCCIONES DE FUNCIONAMIENTO (Continuación)

Posición de la Rejilla y la Bandeja para Horno

<p>Posición 1: Freír con Aire, Recalentar, Rostizar, Asar, Congelado, A la Parrilla y Deshidratar</p>		
<p>Posición 2: Freír con Aire, Recalentar, Waffle, Hornear, Pizza, Asar, Congelado, Deshidratar, Tostar y Bagel</p>		
<p>Posición 3: Freír con Aire, Recalentar, Waffle, Hornear, Pizza, Congelado, Deshidratar, Tostar y Bagel</p>		<p style="text-align: center;">Partes</p>  <p>Canastilla Para Freír</p>  <p>Rajilla De Cocina</p>  <p>Bandeja para horno/ rejilla para asar</p>
<p>Posición 4: Recalentar, Congelado, Deshidratar, Tostar y Bagel</p>		

NOTA: Para pollo u otros alimentos grandes, use la Posición 1 como se muestra arriba.

Consejos Útiles

1. Para agregar más tiempo durante el ciclo de cocción actual, gire "START/PAUSE" en el sentido de las manecillas del reloj. Controle los alimentos para asegurarse de que no se cocinen demasiado.
2. Algo de humedad puede aparecer en la puerta durante ciertos ciclos de cocción.
3. Cuando se fríe con aire, los alimentos se pueden cubrir ligeramente con aceite para aumentar la textura crujiente y dorado.

CUIDADO Y MANTENIMIENTO

Antes del Primer Uso:

Lave todas las piezas¹ extraíbles con agua jabonosa tibia o en el lavavajillas, sólo en la rejilla superior.

1. Retire todos los materiales de embalaje.
2. Retire el pegamento y las etiquetas en el aparato.
3. Limpie las Canastillas de cocción, la Bandeja para Hornear, la Rejilla para Asar, la Canastilla para Freír y la Bandeja para Migajas cuidadosamente con agua caliente, una esponja no abrasiva y un detergente suave para platos, o en el lavavajillas, sólo en la rejilla superior.
4. Enjuague la Piedra para Pizza con agua caliente antes de usarla. Permita que la piedra se seque por lo menos 30 minutos y luego colóquela en el horno muy caliente durante 30-45 minutos. Apague el horno y deje que la Piedra para Pizza se enfríe completamente antes de tocarla.
5. Limpie el interior y el exterior del aparato con un paño húmedo o mojado.

PRECAUCIÓN: No sumerja el Bravo en agua.

PRECAUCIÓN: No sumerja el aparato en agua o intente lavarlo en el lavavajillas.

Limpiar después de cada uso:

1. Permita que la unidad se enfríe completamente antes de limpiarla.
2. Desenchufe siempre el horno de la toma de corriente. NUNCA limpie la unidad mientras está enchufada.
3. Nunca use limpiadores abrasivos, ya que pueden dañar el acabado. Limpie el exterior con un paño limpio y húmedo y séquelo bien.
4. Aplique el agente de limpieza directamente a una toalla de tela, no directamente a la unidad, antes de limpiarlo.
5. Para limpiar el interior, use un paño húmedo, una solución de jabón líquido suave y una toalla de tela limpia.
6. Nunca use abrasivos fuertes o productos corrosivos. Estos podrían dañar la superficie del horno.
7. Nunca use fibras de acero en el interior o el exterior del horno.
8. NUNCA MUEVA UNA PIEDRA PARA PIZZA CALIENTE. Permita que la Piedra para Pizza se enfríe por completo antes de limpiarla. Una vez que se haya enfriado, limpie la piedra con una toalla limpia y húmeda, luego enjuáguela en un fregadero con agua fría y séquela por completo. **ADVERTENCIA:** NUNCA sumerja o enjuague una Piedra para Pizza caliente en agua. La piedra caliente se puede agrietar y romper dentro del agua causando lesiones.



¹ Piedra para Pizza se vende separadamente. TODOS los accesorios (EXCEPTO la Piedra para Pizza) deben lavarse a mano con agua jabonosa caliente.

CUIDADO Y MANTENIMIENTO (Continuación)

9. Cuando la puerta de vidrio esté completamente fría, rocíe el limpiador de vidrios sobre una toalla de tela limpia. Limpie la puerta por dentro y fuera. Use un paño húmedo para enjuagar la puerta y luego seque completamente con una toalla limpia y seca.
10. Para quitar las migajas, deslice hacia afuera la Bandeja para Migajas y deseche las migajas. Límpiela y coloque nuevamente. La Bandeja de Migajas debe vaciarse y limpiarse después de cada uso.
11. Para eliminar la grasa horneada, sumerja la bandeja en agua caliente y jabonosa. Nunca utilice el horno sin la bandeja de migajas en su lugar.
12. Nunca enrolle el cable alrededor de la unidad.

Almacenamiento

- Desenchufe el aparato y déjelo enfriar por completo.
- Asegúrese de que todas las partes estén limpias y secas.

SOLUCIÓN DE PROBLEMAS

El Bravo fue diseñado con una función de apagado automático para evitar el sobrecalentamiento durante el uso. Si el Bravo se apaga para enfriarse, un olor puede ser detectado. Desenchufe la unidad y espere a que se enfríe por completo. Para evitar que el Bravo se sobrecaliente, no cocine alimentos a temperaturas más altas o más tiempo de lo recomendado.

Problema	Posibles causa(s)	Solución (es):
El Bravo no funciona.	El aparato no está conectado. No presionó el botón "ON/OFF".	Inserte la clavija en una toma de corriente con conexión a tierra adecuada. Presione el botón "ON/OFF". Si aún no funciona, comuníquese con Servicio al Cliente al 1-877-689-2838 o envíe un correo electrónico a help@nuwavenow.com .
La puerta del Bravo no se cierra por completo.	El alimento es demasiado grande. Las rejillas o accesorios del horno no están colocados correctamente en su lugar.	Use cantidades más pequeñas de comida para cocinar. Asegúrese de que todas las rejillas y bandejas estén colocados en su lugar y posicionados completamente hasta la parte posterior de la unidad.
La comida no se cocina de manera uniforme.	Dependiendo del tamaño y la cantidad de alimentos que se cocinarán, es posible que se tengan que girar o rotar durante la cocción.	Verifique el progreso de cocción mientras cocina. Gire o rote el alimento según sea necesario para asegurar una cocción uniforme.

SOLUCIÓN DE PROBLEMAS (Continuación)

Problem	Possible Cause(s)	Solution(s):
Hornear vs. Rostizar vs. Asar	Cuándo usar estas tres funciones.	Use Hornear al cocinar los alimentos que esponjan (es decir, pasteles y galletas). Use Rostizar para alimentos densos que se doren durante el proceso de cocción. Use Asar para dorar o hacer crujiente rápidamente un alimento.
La Bandeja para Migajas no regresa a su posición original.	La Bandeja para Migajas no es colocada correctamente en la ranura. Algo está bloqueando que la bandeja se deslice en su posición.	Retire la Bandeja para Migajas y limpie los alimentos que puedan haberse acumulado en la parte posterior de la unidad.
Hay humo blanco saliendo del aparato.	Está cocinando comidas grasosas. La bandeja contiene residuos grasosos de usos anteriores.	Al preparar ingredientes grasos en la unidad, grandes cantidades de aceite pueden hacerse humo. El aceite producirá humo blanco. Esto no afectará el efecto de cocción final. El humo blanco es causado por la grasa que se calienta en las Rejillas y/o en la Bandeja para Migajas. Limpie las Rejillas para cocinar y la Bandeja para Migajas con regularidad entre cada uso.
La pantalla LED está en blanco.	La unidad se sobrecalentó y se apagó. No se tomaron medidas después de ciertas etapas de cocción y la unidad se apagó. El Panel de Control no está trabajando correctamente.	Desenchufe el Bravo y permita que la unidad se enfríe por completo. Vuelva a enchufarlo y vea si está funcionando. Si la pantalla LED permanece en blanco, comuníquese con Servicio al Cliente al 1-877-689-2838 o por correo electrónico a help@nuwavenow.com
El Bravo no está calentando	La unidad está desconectada. La unidad se ha sobrecalentado. Los elementos de calor no funcionan.	Asegúrese de que la unidad esté conectada. Asegúrese que la unidad esté completamente fría y conectada y vea si la unidad alcanza la temperatura. Si continúa sin calentarse, comuníquese con Servicio al Cliente al 1-877-689-2838 o envíe un correo electrónico a help@nuwavenow.com

SOLUCIÓN DE PROBLEMAS (Continuación)

Si la unidad necesita ser reemplazada o devuelta al fabricante, por favor póngase en contacto con nuestro Servicio al cliente al 1-877-689-2838 o envíe un correo electrónico: help@nuwavenow.com

Comuníquese con Servicio al Cliente si ocurre alguno de estos errores:

Código	Er1	Er2	Er3	Er4
"Prob" Error	Cortocircuito de la sonda	Cortocircuito de NTC	NTC abierto	NTC Sobrecalentamiento

GARANTÍA LIMITADA

El Horno Inteligente Bravo

LAS GARANTÍAS DEL FABRICANTE

El Bravo, que incluye la Base de Alimentación, Rejillas de Cocina de uso Rudo, Bandeja Esmaltada, Rejilla Esmaltada para Asar, Canastilla Cromada para Freír con Aire, Bandeja para Migajas Extraíble, Sensor de Temperatura y todos los componentes eléctricos están garantizados por 3 años a partir de la fecha de compra, bajo uso doméstico normal, y cuando se opere de acuerdo con las instrucciones escritas por el fabricante.

El fabricante proporcionará las piezas y el trabajo necesarios para reparar cualquier pieza del Bravo en el Departamento de Servicio de NuWave, LLC. Después de la expiración de la garantía, el costo de la mano de obra y las partes será responsabilidad del propietario.

LA GARANTÍA NO CUBRE

La garantía limitada se anula si las reparaciones son realizadas por un distribuidor no autorizado y/o si la placa de datos del número de serie es retirada y/o desfigurada. El deterioro normal del acabado debido al uso o la exposición no está cubierto por esta garantía. Esta Garantía limitada no cubre fallas, daños o rendimiento inadecuado debido a accidentes, fenómenos de fuerza mayor (como rayos), fluctuaciones en la energía eléctrica, alteraciones, abuso, uso indebido, aplicaciones incorrectas, atmósferas de tipo corrosivo, instalación incorrecta, falla al operar de acuerdo con las instrucciones escritas por el fabricante, uso anormal o uso comercial. NuWave, LLC se reserva el derecho de anular la Garantía Limitada, cuando lo permita la ley, para productos comprados a un distribuidor no autorizado.

GARANTÍA LIMITADA (Continuación)

PARA OBTENER SERVICIO

El propietario tendrá la obligación y la responsabilidad de: pagar todos los servicios y piezas no cubiertos por la garantía; prepagar el envío hacia y desde el Departamento de Servicio para cualquier pieza o sistema devuelto bajo esta garantía; y empacar cuidadosamente el producto con material de relleno adecuado para evitar daños en el tránsito. El contenedor original es ideal para este propósito. Incluya en el paquete el nombre del propietario, la dirección, el número de teléfono durante el día, una descripción detallada del problema y su "número de RGA". Llame al 1-877-689-2838 o envíe un correo electrónico a help@nuwavenow.com para obtener el número de RGA (número de autorización de devolución de mercancías). Proporcione el modelo de sistema de cocción y el número de serie y comprobante de la fecha de compra (una copia del recibo) cuando presente una reclamación bajo esta garantía.

OBLIGACIÓN DEL FABRICANTE

La obligación del fabricante en virtud de esta Garantía limitada está limitada, en la medida en que lo permita la ley, a la reparación o sustitución de cualquier parte cubierta por esta Garantía limitada que, tras el examen, se considere defectuosa durante el uso normal. La Garantía limitada solo se aplica dentro de los Estados Unidos continentales y solo al comprador original de los canales de distribución autorizados por el fabricante. LA GARANTÍA LIMITADA NO PUEDE SER ALTERADA, VARIADA O EXTENDIDA, EXCEPTO POR UN INSTRUMENTO ESCRITO EJECUTADO POR EL FABRICANTE. EL RECURSO DE REPARACIÓN O REEMPLAZO SEGÚN LO DISPUESTO BAJO ESTA GARANTÍA LIMITADA ES EXCLUSIVO. EN NINGÚN CASO EL FABRICANTE SERÁ RESPONSABLE DE NINGÚN DAÑO CONSECUENTE O INCIDENTAL PARA CUALQUIER PERSONA, YA SEAN OCASIONADOS POR LA NEGLIGENCIA DEL FABRICANTE, INCLUIDOS, ENTRE OTROS, LOS DAÑOS POR PÉRDIDA DE USO, COSTOS DE SUSTITUCIÓN, DAÑO A LA PROPIEDAD U OTRA PÉRDIDA DE DINERO.

Algunos Estados no permiten la exclusión o limitación de daños incidentales o consecuentes, por lo que las exclusiones de limitación anteriores pueden no ser aplicables. Esta Garantía Limitada otorga derechos legales específicos, y también puede haber otros derechos que varían de estado a estado. CON EXCEPCIÓN DE LO DISPUESTO EXPRESAMENTE ANTES, EL FABRICANTE NO OFRECE GARANTÍAS EXPRESAS O IMPLÍCITAS DERIVADAS DE LA LEY O DE CUALQUIER OTRA ÍNDOLE, INCLUIDAS, ENTRE OTRAS, LAS GARANTÍAS IMPLÍCITAS DE COMERCIABILIDAD E IDONEIDAD PARA UN PROPÓSITO EN PARTICULAR CON CUALQUIER OTRA PERSONA. LEA SU MANUAL DEL PROPIETARIO. SI AÚN TIENE ALGUNA PREGUNTA ACERCA DE LA OPERACIÓN O GARANTÍA DEL PRODUCTO, COMUNÍQUESE CON NUWAVE, LLC.

LEA SU MANUAL DEL PROPIETARIO

Si aún tiene alguna pregunta sobre el funcionamiento o la garantía del producto, comuníquese con NuWave, LLC al: 1-877-689-2838 o envíe un correo electrónico a help@nuwavenow.com.

**Brio® 6-Qt
Digital Air Fryer**



**Nutri-Pot® 6-Qt
Digital Pressure Cooker**



**NuWave Oven®
Pro Plus**



**NuWave PIC® Gold
Precision Induction Cooktop**



**BruHub®
Coffee Maker**



**Moxie® High-Performance
Vacuum Blender**



**Duralon® Healthy Ceramic
Non-Stick Cookware**

nuwave®
— LIVE WELL FOR LESS —

www.nuwarennow.com



FOR HOUSEHOLD USE ONLY

Model: 20801, 120V, 60Hz, 1800 Watts

For patent information please go to: www.nuwarennow.com/legal/patent

Designed & Developed in USA by:

NuWave, LLC

1795 N. Butterfield Road
Libertyville, IL 60048, U.S.A.

Customer Service:

1-877-689-2838 • help@nuwarennow.com

Made in China

©2018 NuWave, LLC • All Rights Reserved.

Item No: BM20801

Rev. 14-OG

09-06-18