

MAASDAM

POWERLIFT™

MPL4699-BL-HV-TH
MPL4699-GR-HV-TH
MPL4699-OR-HV-TH

USE AND CARE GUIDE

3 TON LOW PROFILE FLOOR JACK WITH SPEEDY LIFT

1-888-797-7855

MAASDAM.COM

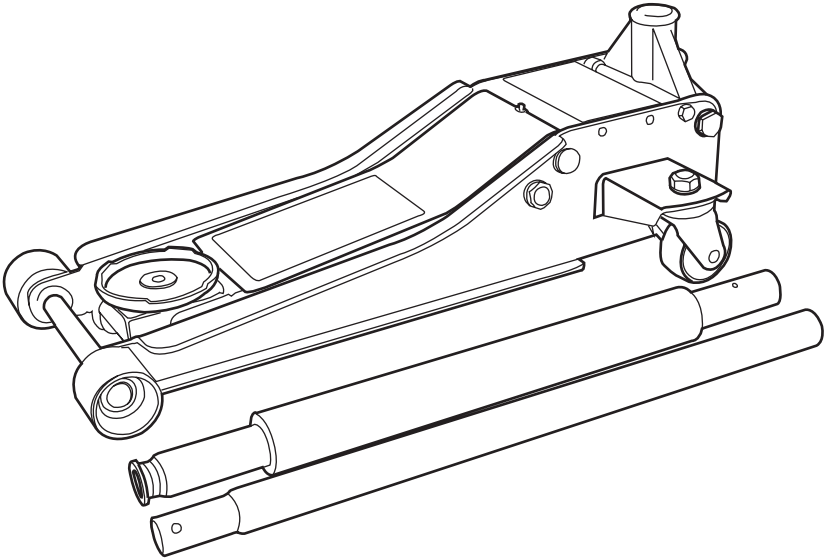



Table of Contents

Safety Information	2	Care and Cleaning	6
Warranty.....	2	Inspection.....	6
Pre-Operation.....	3	Maintenance	6
Before Assembly and Operation	3	Replacing Hydraulic Jack Oil.....	6
Specifications.....	3	Lubricating the Jack.....	6
How It Works.....	3	Storing the Jack.....	6
Garage Jack Package Contents.....	3	Cleaning the Jack.....	6
Jack Operation	4-5	Troubleshooting	7
Tool Set Up	5	General Operation	8
Attaching the Handle.....	5	Lifting	8
Bleeding	5	Lowering	8
Adding Oil.....	5	Exploded View	9

Safety Information

READ AND SAVE THESE INSTRUCTIONS

1. Read, understand, and follow all instructions before operating this device prior to use.
2. Do not overload this jack beyond the rated capacity.
3. This jack is designed for use only on hard level surfaces capable of sustaining the load. Use on other than hard level surfaces can result in jack instability and possible loss of load.
4. This is a lifting device only. Immediately after lifting, support the vehicle with jack stands.
5. Inspect the jack prior to each use. Do not attempt use if the unit is broken, bent, cracked, or has missing and/or damaged parts. Replace broken, bent, cracked, missing and/or damaged parts, and/or missing labels, warnings and/or decals with factory authorized parts prior to use.

 **WARNING:** This jack is a lifting device only. It is not a support device. NEVER place yourself under or near a raised vehicle supported by a jack. Immediately after lifting, support the vehicle with jack stands or other appropriate means.

 **CAUTION:** Do not move or dolly the vehicle while on the jack.

 **CAUTION:** Any jack that appears to be damaged or has worn parts should be removed from service immediately.

 **IMPORTANT:** Lift only on areas of the vehicle as specified by the vehicle manufacturer. Use the vehicle manufacturer's instructions on proper lifting.

 **NOTE:** Center the load on the saddle prior to lifting.

 **NOTE:** Use of garage and bottle jacks on sea vessels is prohibited.

 **NOTE:** Some vehicles require an adapter to properly engage the frame for lifting

 **NOTE:** Failure to heed these warnings may result in personal injury and/or property damage.

 **WARNING:** Risk of cancer and reproductive harm from exposure to di(2-ethylhexyl) phthalate (DEHP). See www.P65Warnings.ca.gov.

 **DANGER:** Because of the potential hazards associated with the misuse of equipment of this type, no alterations shall be made to the product without written authorization of the manufacturer or supplier.

 **WARNING:** Do not get under or allow anyone under the vehicle until it has been supported by jack stands.

 **WARNING:** For your safety and to prevent injury, use the service jack for lifting purposes only.

Warranty

Maasdam Pow'R Lift™ (the "Manufacturer") provides a 1 year limited warranty on our quality manufactured products only to be free from defects in workmanship and factory materials so long as the product is used and maintained properly and in accordance with the Operations and Safety Manual and information which accompany and relate to the product.

Manufacturer shall have the sole discretion to inspect and determine whether Purchaser has used and maintained the tool properly for purposes of application of this warranty. The sole monetary limit and measure of damages of Manufacturer shall be the price of the defective unit, and Manufacturer shall have no liability or responsibility for consequential or any other kind of damage caused by the defective unit or any of its parts, including, but not limited to, loss of use, commercial loss or loss of business. This 1 year limited warranty is extended only to the first purchaser of this product and only if the product is used as intended by the Manufacturer.

Pre-Operation

BEFORE ASSEMBLY AND OPERATION

Compare all parts with the Package Contents lists in this manual. If any part appears missing or damaged, do not use this product. Contact the Customer Service at 1-888-797-7855 or visit www.maasdam.com.

SPECIFICATIONS

Model	Jack Dimensions	Max Load Capacity	Lifting Range	Saddle Dimensions	Jack Weight
3 Ton Low Profile Floor Jack with Speedy Lift	29.125 in. x 13.5 in. x 6.25 in.	6,000 lbs	3 to 19.75 in.	4.3 in. Diameter	78.1 lbs.

HOW IT WORKS

The jack power unit consists of a plunger, plunger cavity, hydraulic oil reservoir, cylinder, and ram. An upward stroke of the jack handle draws oil from the reservoir into the plunger cavity. Hydraulic pressure closes a valve that keeps oil in the cavity. A downward stroke of the jack handle forces oil into the cylinder, pushing out the ram and raising the saddle.

 **NOTE:** As a protective feature, when the ram reaches maximum extension, sufficient oil passes back into the reservoir to prevent an overextended ram stroke and possible jack damage.

When the release valve is open, oil flows back into the reservoir, causing the ram to retract, lowering the saddle.

GARAGE JACK PACKAGE CONTENTS

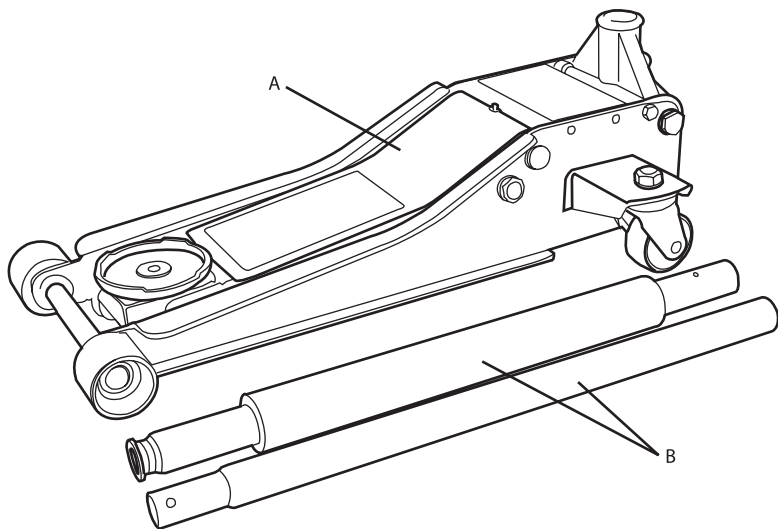

Part	Description	Quantity
A	3 Ton Floor Jack	1
B	Handle	1

Jack Operation

1 Inserting the handle

- Insert the handle (B) into the handle socket of the jack (A). Ensure the pin on the lower end of the handle (B) snaps into the socket slot.

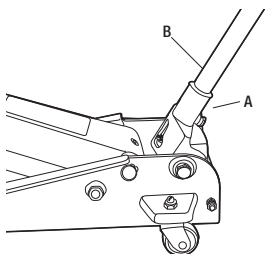

2 Placing the vehicle in park

- Place the vehicle in PARK and apply the emergency brake.

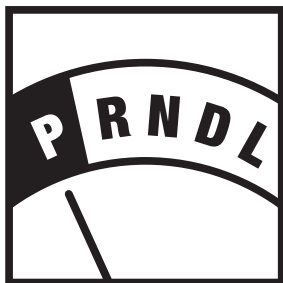

3 Closing the jack

- Close the jack release valve by turning the handle (B) clockwise.

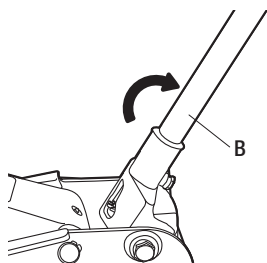

4 Blocking the wheels

- Block the vehicle wheels that are not being raised.



5 Centering the jack

- Center the jack under the load so that the saddle (1) contacts the load firmly and will not slip. (Refer to the vehicle manufacturer's owner's manual to locate the approved lifting points on the vehicle).

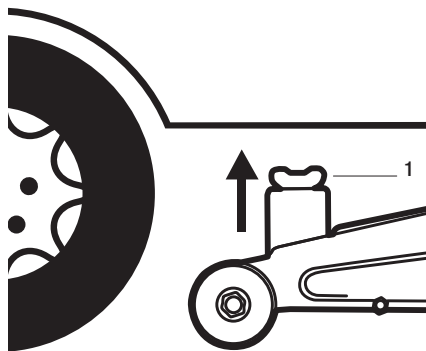

Jack Operation (continued)

6 Lifting the vehicle



WARNING: To avoid pinching or crushing hands or feet, ALWAYS keep them clear of the jack hinge and ground contact area when lowering the vehicle. The jack is a lifting device only. DO NOT move or dolly the vehicle while it is on the jack.

- Pump the jack handle (B) until the saddle (1) nears contact with the vehicle. Check to see that the saddle (1) is centered and will contact the lifting point firmly.
- Continue to pump the jack handle (B) to lift the vehicle to a height slightly above the jack stands or other supports. Then turn the handle (B) very slowly counterclockwise to open the release valve to lower the vehicle onto the supports.

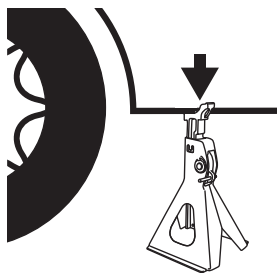
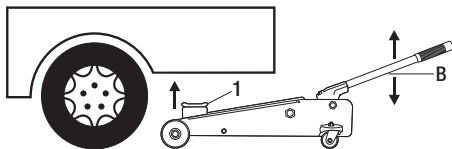

Tool Set Up

ATTACHING THE HANDLE

1. Fasten the Upper handle to the Lower Handle.
2. Loosen the Set Screw and insert the assembled Handle into the Handle Socket.
3. Tighten the Set Screw.

BLEEDING

1. Loosen the Fill Screw.
2. Insert the Handle into the Handle Socket to operate the Release Valve.
3. Turn the Handle counterclockwise to open the valve.
4. Pump the Handle up and down quickly several times to purge air from the system.
5. Tighten the Fill Screw.

ADDING OIL

1. Remove the Fill Screw.
2. Add high grade hydraulic fluid into the Fill Screw slowly until the oil reaches the top of the oil fill hole.
3. Replace the Fill Screw.



NOTE: Do not touch the handle when adding hydraulic oil.

Care and Cleaning

INSPECTION

Maintain the product according to these instructions. You may not alter this product in any way.

1. Before using, inspect the jack thoroughly. Look for cracks in the welds, bent, damaged, loose, worn or missing parts.
2. Inspect according to this manual **ONLY**.
3. If the jack has been subjected to abnormal load or shock (abuse), perform an immediate inspection. Take the product to a local customer service representative for an authorized inspection before use.

Maintenance

CLEANING, MAINTENANCE AND LUBRICATION



CAUTION: To prevent serious injury from tool failure: Do not use damaged equipment. If abnormal noise or vibration occurs, have the problem corrected before further use.



IMPORTANT: Procedures not specifically explained in this manual must be performed by a qualified technician.

1. Before each use, inspect the general condition of the jack. Check for broken, cracked or bent parts, loose or missing parts, and any condition that may affect the proper operation of the product. If a problem occurs, have the problem corrected before further use.

DO NOT USE DAMAGED EQUIPMENT

2. Before each use, thoroughly test the jack for proper operation prior to its actual use. If the jack appears not to be working properly, follow bleeding instructions on page 5.
3. Change the hydraulic oil at least once every three years.
 - A. With the jack fully lowered, remove the Oil Filler Plug on the side of the housing.
 - B. Tip the jack to allow the old hydraulic oil to drain out of the housing completely, and dispose of the old hydraulic fluid in accordance with local regulations.
 - C. With the jack upright, completely fill the housing with a high quality hydraulic oil (not included) until the oil is 1/4" below the fill hole.
 - D. Open the valve by turning the handle counterclockwise and pump the handle to bleed air from the system.
 - E. Recheck oil level and re-fill as needed.
 - F. Reinstall the Oil Filler Plug.
4. Wipe dry with a clean cloth. Then, store the jack in a safe, dry location out of reach of children and other non-authorized people.

Troubleshooting

Problem	Probable Cause	Solution
The jack will not lower completely.	<ul style="list-style-type: none"> <input type="checkbox"/> There is air in the hydraulic system. <input type="checkbox"/> The release valve is stuck. 	<ul style="list-style-type: none"> <input type="checkbox"/> Purge air from the hydraulic system. <input type="checkbox"/> Transfer the weight load and clean the valve.
The jack will not hold weight.	Release the valve in open position. Check the locking pin and release handle to make sure they are functioning properly.	Close the release valve tightly.
The jack will not raise.	<ul style="list-style-type: none"> <input type="checkbox"/> The oil level is low. <input type="checkbox"/> There is air in the hydraulic system. 	<ul style="list-style-type: none"> <input type="checkbox"/> Fill to recommended level. <input type="checkbox"/> Purge air from the hydraulic system.
The jack lifting is weak.	<ul style="list-style-type: none"> <input type="checkbox"/> There is air in the hydraulic system. <input type="checkbox"/> The oil is dirty. <input type="checkbox"/> The release valve is not completely closed. 	<ul style="list-style-type: none"> <input type="checkbox"/> Purge air from the hydraulic system. <input type="checkbox"/> Change the oil. <input type="checkbox"/> Close the release valve tightly.
The jack will not lift the load.	<ul style="list-style-type: none"> <input type="checkbox"/> The weight is excessive. <input type="checkbox"/> The release valve is in the open position. <input type="checkbox"/> The oil level is low. 	<ul style="list-style-type: none"> <input type="checkbox"/> Decrease the weight or change to a higher capacity jack. <input type="checkbox"/> Turn the valve clockwise and tighten. <input type="checkbox"/> Fill to a recommended level.
The lift arm will not lower.	Check the locking pin and release handle to make sure they are functioning properly.	Call customer service.

WARNING: TO PREVENT SERIOUS INJURY: Use caution when troubleshooting a malfunctioning jack. Stay clear of the supported load. Completely resolve all problems before use. If the solutions presented in the Troubleshooting guide do not solve the problem, have a qualified technician inspect the and repair the jack before use.



After the jack is repaired: Test it carefully without a load by raising and lowering it fully, checking for proper operation, **BEFORE RETURNING THE JACK TO OPERATION**

General Operation

LIFTING



WARNING: Park vehicle on a flat, level, solid surface safely away from oncoming traffic. Turn off the vehicle's engine. Place the vehicle's transmission in "PARK" (if automatic) or in its lowest gear (if manual). Set the vehicle's emergency brake. Then, chock the wheels that are not being lifted.

1. Turn the handle counterclockwise to lower the jack. Once the jack is fully lowered, turn the handle firmly clockwise to close it.
2. Carefully position the saddle of the jack under the vehicle manufacturer's recommended lifting point. (See vehicle manufacturer's owner's manual for location of frame lifting point.)
3. Pump the handle until the top of the jack's saddle has nearly reached the vehicle lifting point. Position the saddle directly under the vehicle's lifting point.
4. To lift the vehicle, pump the handle of the jack. Use smooth, full strokes.
5. Once the vehicle is raised, slide a jack stand of appropriate capacity (not included) under a proper lifting point referred to in the vehicle owner's manual. Always use two jack stands, position them at the same point on each side of the vehicle



WARNING: The rated capacity of jack stands is per pair, not the individual capacities combined unless specifically noted on the product by the jack stand manufacturer. Do not exceed rated jack stand capacity. Ensure that the vehicle support points are fully seated in the saddle of both jack stands. Use a matched pair of jack stands per vehicle to support one end only. Failure to do so may result in the load suddenly falling, which may cause personal injury and/or property damage.

6. Center the vehicle's lifting point(s) on the center of the jack stand(s). Set the jack stand(s) to the same height according to the manufacturer's instructions, making sure that they lock securely into position.
7. Slowly turn the handle counterclockwise to lower the vehicle onto the saddle(s) of the jack stand(s). Then, turn the handle firmly clockwise to close it.

LOWERING

1. Carefully remove all tools, parts, etc. from under the vehicle.
2. Position the saddle under the lifting point. Turn the handle firmly clockwise and raise the load high enough to clear the jack stands, then carefully remove the jack stands.
3. Slowly turn the handle counterclockwise (never more than 1/2 full turn) to lower the vehicle onto the ground.
4. Lower the jack completely. Then, store in a safe, dry location out of reach of children.

Exploded View

3 TON LOW PROFILE FLOOR JACK

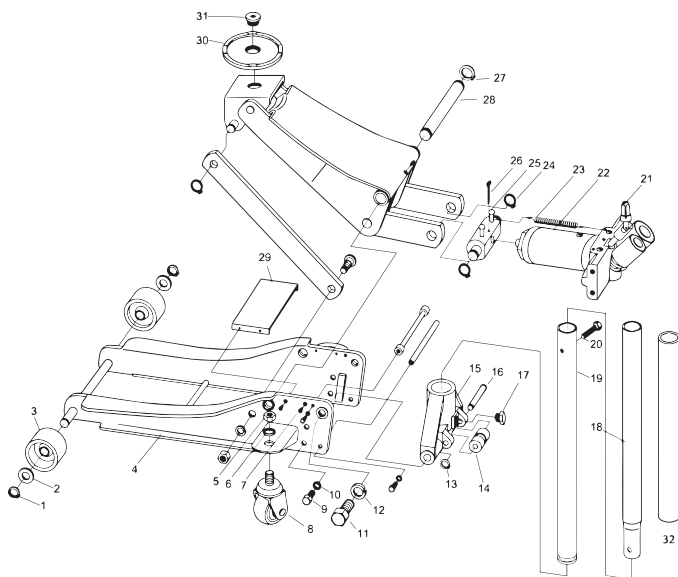

Part	Description	Quantity
1	Retaining Ring (M20)	2
2	Washer (M20)	2
3	Front Wheel	2
4	Frame	1
5	Nut (M16)	4
6	Washer (M16)	4
7	Screw (M5x12)	4
8	Rear Caster Assembly	2
9	Screw (M10x20)	4
10	Washer (M10)	4
11	Bolt	2
12	Washer (M18)	2
13	Retaining Ring (M12)	1
14	Handle Socket Roller	1
15	Handle Socket	1
16	Shaft	1

Part	Description	Quantity
17	Set Screw	1
18	Upper Handle	1
19	Lower Handle	1
20	Screw (M6x35)	1
21	U-Joint	1
22	Hydraulic Unit	1
23	Spring	2
24	Retaining Ring (M22)	2
25	Hydraulic Unit Adaptor	1
26	Pin (A4x55)	1
27	Retaining Ring (M25)	2
28	Lift Arm Shaft	1
29	Cover Plate	1
30	Saddle	1
31	Saddle Screw	1
32	Handle Bumper	1



1-888-797-7855

WWW.MAASDAM.COM

Retain this manual for future use.