



ARIA

By modernhome

Ceramic Air Fryer

User Guide

3QT / 1000 Watts

CCT - 887 & CCB - 883



ariaairfryer.com

Follow Us for video tutorials, recipes, and more!



facebook

ARIAAIRFRYERS



instagram

ARIAAIRFRYERS

HEALTHY
STARTS HERE

Congratulations on your new Ceramic Air Fryer
and thanks for choosing Modernhome

Your Ceramic Air Fryer is a practical, multi-function appliance that uses incredibly hot air and rapid air circulation to evenly cook your food from all angles, without using extra oil or grease. This leads to deliciously crispy food in a snap with less fat, calories, grease, and harmful chemicals. Almost any food that can be prepared in a conventional, microwave, or convection oven can be fried, baked, roasted, or grilled in your new Air Fryer.

We worked hard to create our helpful recipe book and dishwasher-safe accessories with a Lifetime Warranty, which lets you spend more time on the things that matter most - like enjoying delicious food, spending time with loved ones, and taking care of yourself. Enjoy your new Air Fryer and the freedom it allows to create healthier lifestyles for yourself and those around you.



ARIA

By modernhome

Ceramic Air Fryer
Quick Start Guide

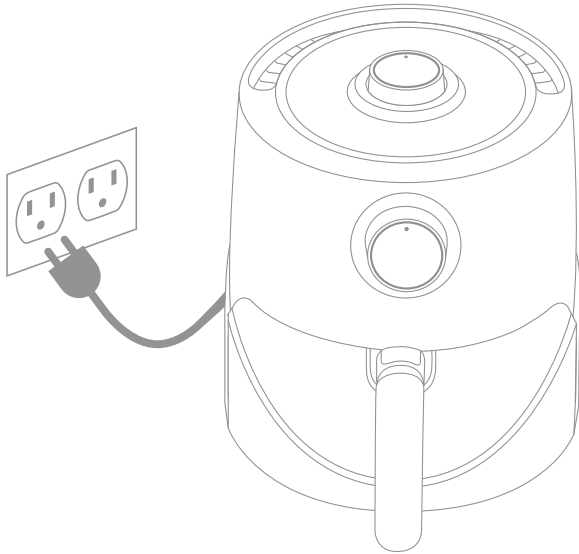

Powering Air Fryer

Place the Air Fryer on an even surface and plug into a grounded wall socket

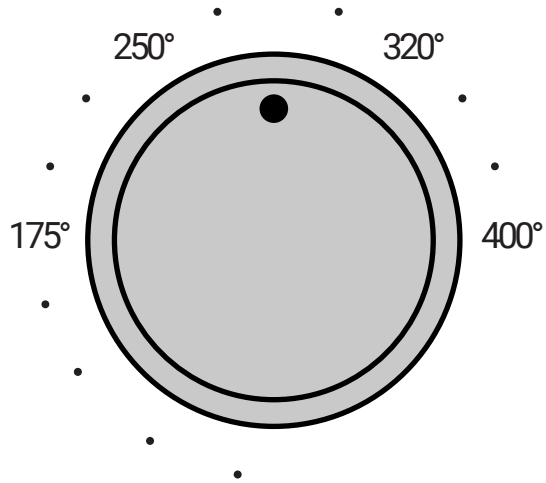

Temperature

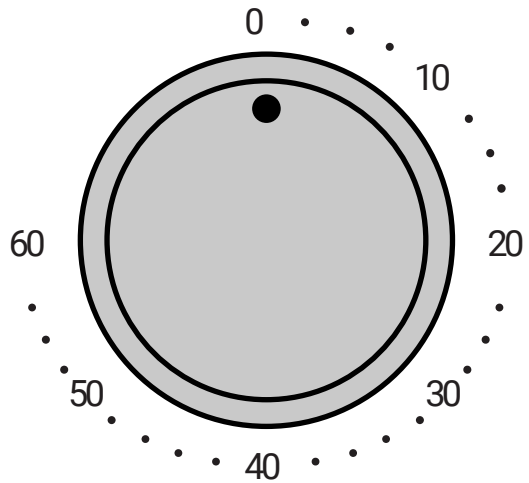

Time

Loading Air Fryer

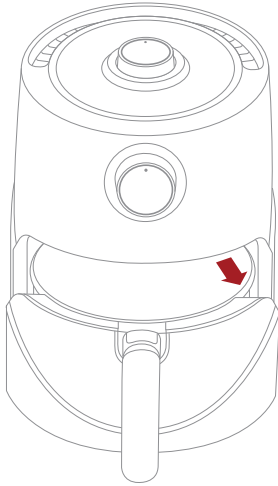

1

Pull Frying Basket
Drawer Out.

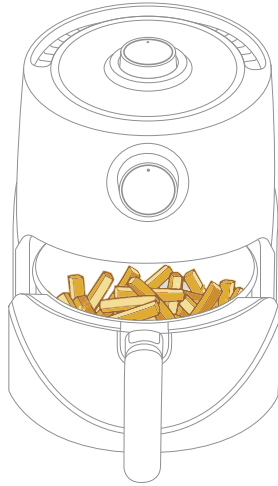

2

Place ingredients into
Frying Basket Drawer.

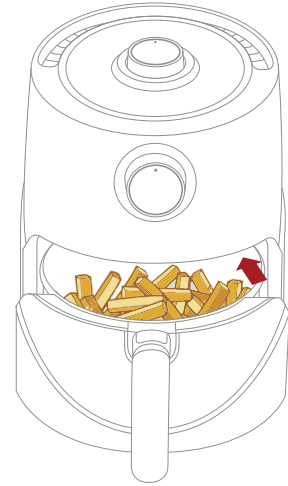

3

Slide the Frying Basket
Drawer back inside the
Air Fryer.

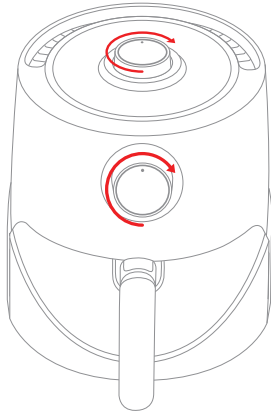

Do not fill the Frying Basket beyond the Max Line as this could have a negative effect on the cooking of the ingredients.

Note: As this fryer works using hot air circulation, do not fill the Drawer or Fryer Basket with oil or frying fat.

4

Select the desired Time/Temp and press the On/Off button to start Air Fryer.

Before First Use

- Remove all packaging materials, plastic, tape, and labels.
- Clean the Frying Basket and Crisping Rack with warm water, soap, and a non-abrasive sponge. As the Frying Basket and Baking Pan have a non-stick, food-safe coating, be sure not to use an abrasive sponge or metal scouring pad as this will damage the coating.

(Tip: The Basket and Rack and also be cleaned in the dishwasher)

- Wipe the inside and outside of the Air Fryer with a dry cloth. **Note:** *The Air Fryer may make some smoke or slight odor the first time you use it. This is normal.*
- Ensure the heating element and fan inside the Air Fryer are both clean and clear from any obstructions.

Note: *This Air Fryer must only be used with the Frying Basket securely inside the appliance.*

Do not attempt to use the Air Fryer without the Frying Basket securely inside the unit.



CAUTION!

- *Some parts of the Air Fryer are extremely hot during operation such as the exterior, interior, trays, and all accessories. Do not touch hot surfaces, parts, accessories, interior or exterior while cooking. Use a heat-resistant oven glove instead of touching the Air Fryer or its accessories directly to avoid bodily injury.*
- *The Air Fryer contains both electronic and heating elements. To avoid electrical shock, do not immerse the power cord, plug, or housing in water or put them under the tap during cleaning.*
- *Prevent any water or other liquids from entering the Air Fryer.*
- *Do not cover the air ventilation inlet and air outlet of the Air Fryer while it's in use.*
- *During cooking, hot steam is released from the air outlet openings. Be sure to keep your hands, face, and all other body parts away to avoid injury. Also, be careful of hot steam and air as you open the Air Fryer or remove the Frying Basket.*

Do not fill the Frying Basket or internal chamber of the Air Fryer with oil or fat as this may cause a fire hazard. The appliance uses hot air to cook.

- *Always allow the Air Fryer and all parts and accessories to cool down completely before handling or cleaning.*
- *Do not clean with metal scouring pads or abrasive sponges and materials.*
- *To prevent a fire, be sure to keep the Air Fryer away from all flamma-*

ble materials, such as curtains, drapes, tablecloths, cloth, wallpapers, and walls.

- *Do not place anything on the top of the Air Fryer or directly behind it.*
- *The Air Fryer is intended for household use only. Do not use the Air Fryer for anything other than its intended use or beyond the specifications of this manual.*
- *In the case of a fire, never attempt to extinguish the flames with water. Immediately unplug the appliance. If safe, smother the flames with a*

damp cloth. Contact emergency services and/or our Customer Care Team.

Cooking Instructions

- 1 Place the Air Fryer on an even surface and plug into a grounded wall socket. Be sure that the Air Fryer is a safe distance (at least 12 inches) from the wall or any other appliances or furniture to avoid damage to the surrounding environment and allow for proper air circulation.
- 2 Pull the Frying Basket Drawer out of the Air Fryer and place the ingredients inside of the Frying Basket.
Note: *Do not fill the Frying Basket beyond the Max Line as this could have a negative effect on the cooking of the ingredients. Note: As this*
- fryer works using hot air circulation, do not fill the Frying Basket Drawer with oil or frying fat.*
- 3 Slide the Frying Basket Drawer back into the Air Fryer and turn the Temperature knob to the desired cooking temperature. (the default temperature is 370 °F).
- 4 Turn the Time Knob to the desired cooking time - this will begin the cooking cycle. The Heating indicator will turn on

- 5 Tap the On/Off button once more to begin the cooking cycle. The spinning blades on the Heating Fan Icon indicate that hot air is circulating in the Air Fryer. **Note:** *When the blades of the Heating Fan Icon are spinning, this indicates that hot air is circulating at high speeds inside the Air Fryer. Keep all body parts away from the Air Outlet vents during this time and be careful of steam and hot air when removing the Frying Basket Drawer.*
- 6 If desired, adjust the temperature and timer using the buttons during the cooking cycle. **Note:** *For the*

best cooking results with smaller ingredients such as fries, pull out the Drawer by the handle and gently shake the ingredients halfway through the cooking time. Be cautious of hot air and steam that may be released. Then slide the Drawer back into the Air Fryer to continue cooking

- 7 When the set preparation time elapses, for 20 seconds the Air Fryer fan may continue to spin allowing the appliance to cool down. After which the Air Fryer will beep 5 times.

Cooking Instructions *(continued)*

- 8 Slide the Frying Basket Drawer out carefully and place it on a heat-resistant surface. **Note:** *Any excess oil will have been collected at the bottom of the Drawer, so do not turn the Drawer upside down as this hot oil will spill.*
- 9 If the ingredients are ready to serve, simply retrieve your food with tongs or other heat-safe tool. **Tip:** *For safety, the Air Fryer will shut off when the Drawer is pulled out. Therefore, when cooking smaller ingredients, you may set the timer for the halfway point and set again for the remaining time after shaking the ingredients.*



We're Here to Help!

Please remember, the safety of you and your loved ones is our top priority. That's why we have the industry's only Lifetime Warranty on all accessories and 1 year warranty on the unit itself. If you're ever having serious issues with your Air Fryer, please stop using it immediately and email or call us.

Email: customercare@skylinebrands.com or
Call: **847.357.9077** between **10am-5pm (CST)**

ariaairfryer.com/support

Note: For your safety, please do not try to fix the appliance by yourself. We're here to help.

| Food | Time | Temp (°F) | Shake/Flip Halfway | Notes |
|----------------|------------|-----------|--------------------|--|
| Frozen Fries | 14-22 min. | 400 | Shake | |
| Handmade | 16-26 min. | 400 | Shake | Soak for 30 mins, dry, then add a half teaspoon of oil before cooking for crispiness |
| Beef / Steak | 10-20 min. | 360 | Flip Over | |
| Pork Chops | 15-24 min. | 380 | Flip Over | |
| Hamburger | 12-20 min. | 360 | Flip Over | |
| Sausage Rolls | 6-12 min. | 360 | Shake | |
| Chicken Breast | 15-25 min. | 380 | Flip Over | |
| Spring Rolls | 8-10 min. | 360 | Shake | |
| Vegetable | 10-25 min. | 360 | Shake | |
| Cake | 14-25 min. | 320 | | |

Note: Please keep in mind that these are general guidelines. Your ingredients may differ in size or thickness so we can't guarantee the best settings for your specific ingredients. Please keep an eye on your food while cooking to insure the best results for you.

Troubleshooting

Problem

Air Fryer Not Working

Solution

Make sure the Air Fryer is plugged into a power outlet. If necessary try another outlet.

Frying Basket isn't completely secured inside

The Air Fryer is not on

Problem

The Air Fryer is especially noisy

Solution

The motor or internals aren't working correctly. Shut the Air Fryer off immediately and safely. Contact Modernhome Customer Care for warranty instructions.

Problem

Food not fully prepared when taken out

Solution

The Frying Basket is overfilled with ingredients.

Temperature is set too low

Cooking time is set too short

Troubleshooting

Problem

Fried ingredients aren't crispy enough

Solution

Use oven snacks or brush a thin layer of oil on the surface of the ingredients before cooking for crispier results

Problem

Home-made French fries are not crispy enough

Solution

Soak the cut potatoes in water for at least 30 minutes to remove the starch, but be sure to dry them properly before cooking. Add a brush of oil or cut the potatoes into thinner fries for crispier results.

Problem

Ingredients aren't cooked evenly

Solution

In the middle of cooking process, carefully lift the Frying Basket out and shake it to separate the overlapped ingredients, then place the Basket back inside and close lid to continue.

Troubleshooting

Problem

The Air Fryer has shut down

Solution

The Air Fryer has an auto-off safety feature which protects it from overheating.

Unplug the unit safely and allow it to cool down completely. Then plug it back in and restart cooking following instructions.

Problem

Smoke is coming out of the Air Fryer

Solution

The Frying Basket, Rack, or inside of the Air Fryer still contains grease or oil from a previous cooking cycle.

White smoke is caused by grease or oil. To prevent this, clean the Frying Basket and the inside of the Air Fryer completely.

Note: *A few ingredients with a high fat content such as bacon or some meats can release excess fat, grease, and oil which can begin to smoke. Please be mindful of this and remove all excess fat and oil inside the Air Fryer as necessary.*

Important Safety Tips

As your Air Fryer is a powerful electrical appliance with heating elements and fans, be sure to follow all safety precautions and read all instructions fully and carefully before using

Warning

Make sure that your outlet's voltage corresponds to the voltage stated on the label of the appliance, and only use with a properly grounded outlet.

As the plug is polarized (one prong is larger than the other), be sure to insert into a polarized outlet the correct way. If the plug does not fit, reverse the plug

and try again, or contact a certified electrician.

Do not modify the appliance in any way.

Before using, check the power cord of appliance and the accessories. Do not use if any part shows any damage. Contact Customer Care if this is the case for warranty assistance.

Before each use, ensure the heating element on top of the Air Fryer and the fan are both clean and clear from any ingredients or food from the previous cooking cycle.

Warning

Keep out of reach of children - they should be supervised to ensure that they do not play with the Air Fryer.

Do not use Air Fryer unattended while in use.

Never use the Air Fryer without the Frying Basket in place.

Immediately unplug the Air Fryer if you see dark smoke coming out of it. Wait for the smoke to stop being released before pulling out the Racks, Trays, or other accessories.

Children over 10 years, anyone with a physical or mental disability, and anyone with a lack of experience and knowledge on how to use the Air Fryer should read the User Guide completely and be guided by someone who has prior experience with using the appliance.

Do not let the power cord contact hot surfaces or hang over the edge of table or counter.

Do not plug in the Air Fryer or operate the appliance or display with wet hands. Do not use this appliance with an extension cord as this can cause a fire hazard. As the Air Fryer gets extremely hot

Warning

during use, prevent fire hazards and do not put plastic or metal dishes, bowls, tools, or protective film into the appliance.

Do not place paper, cardboard, or any similar materials into the Air Fryer. If using parchment or baking paper, be sure to place your food securely on top of the paper before putting it in the Air Fryer. The extremely light paper could be lifted by the fan and touch the heating elements, causing a fire hazard.

The Air Fryer should be placed on a horizontal and stable surface, away from water and all liquids when being used.

Do not place it on plastic, any boards, or any other surface that can get too hot or damaged.

Do not place the Air Fryer against a wall or other appliances. There should be a space of 12 inches all around the Air Fryer while it's in use or directly after its use (since it will be hot.)

Do not leave the Air Fryer unattended.

Once cooking is completed and you are taking out the Basket or food, the heating element at the top of the unit will have a very high temperature. Do not touch it.

Warning

If the preset time is too long the food will be burnt and dark smoke will be released from the air outlet. Unplug the Air Fryer immediately and allow it to cool completely. After it cools, clean the food and oil in the Frying Basket in addition to all the accessories.

After using the Air Fryer, press the power button to turn the appliance off, then safely pull the plug from the socket. Avoid pulling the power cord too harshly to prevent damage and electric shock.

Unplug the Air Fryer from the outlet

when it is not in use or before cleaning it. Always allow the appliance to cool down completely first before cleaning.

Do not use any 3rd party accessories.

This appliance is intended to be used in a household. Do not use outdoors.

If the appliance is used improperly, or for professional or semi-professional purposes, or if it is not used according to the instructions in the User Guide, the warranty becomes invalid and Skyline Brands Inc refuses any liability for damage caused.

The Air Fryer has a few built-in safety

Warning

features that won't allow it to turn on unless the Frying Basket is securely inside the appliance. Once you push the Basket in far enough, you will hear a click indicating it's been fully closed.

Always unplug the Air Fryer when it's not being used.

Care, Cleaning & Maintenance

For optimal efficiency and long-term care, clean the Air Fryer after each use.

- 1** Since the Air Fryer and internal parts get very hot during use, unplug the power cable and let the Air Fryer cool for at least 30 minutes before handling or cleaning any parts. **Note:** *Remove the Frying Basket and all other accessories carefully to let the Air Fryer cool more quickly before cleaning.*
- 2** Clean the Frying Basket and Rack with hot water, a minimal amount of soap, and a non-abrasive sponge. To avoid damage to the parts, do not use a hard-wire cleaning tool.
- 3** The Frying Basket and the Rack are dishwasher-safe for easier cleaning.
- 4** Clean the inside of the Air Fryer with hot water and a non-abrasive sponge.
- 5** Wipe the surface of the Air Fryer with a moist cloth. Do not use corrosive liquids for cleaning.
- 6** Always keep the power cord of the Air Fryer dry and away from water to prevent electric shock and damage to the appliance.

- 7 For long-term storage, unplug the Air Fryer, allow it to cool down, properly clean and dry all the parts, put the components into the box, and store it in a cool, dry place. This warranty applies to products purchased and used only in the U.S and Canada and does not cover wear and tear from improper use or

Warning

If the appliance is used improperly, or for professional or semi-professional purposes, or if it is not used according to the instructions in the User Guide, the warranty becomes invalid and Skyline Brands refuses any liability for damage caused.

Warranty Terms

not following instructions as specified in the print manuals. Furthermore, we exclude all claims resulting from misuse, special, incidental, and consequential damages. All liability is limited to the amount of the purchase price. After a period of 90 days, we will still repair or replace the product at no cost however, may ask you to help pay for the shipping cost associated with the product.



Hassle-Free Warranty

Skyline Brands, Inc.

4801 Emerson Ave.

Palatine, IL 60067

To make a warranty claim, do not return this appliance to the store.

Please call 1.847.357.9077 in the U.S. or Canada between 9:00am - 5:00pm (CST)

Monday through Friday.

or email customer@skylinebrands.com

Follow Us for video tutorials, recipes, and more!

ariaairfryer.com



facebook

ARIAAIRFRYERS



instagram

ARIAAIRFRYERS

