

## **LARGE SIDE RAIL KIT 8272**

### **FITS 1500 SERIES TRAILERS**

PART NO. 108272

INSTRUCTIONS NO.-104873

**THIS SIDE RACK KIT IS INTENDED FOR INSTALLATION ON POLAR TRAILERS WITH AN EMBOSSED POLAR TUB LOGO ONLY AND WILL NOT FIT OLDER TRAILERS WITH AN APPLIED POLAR TUB DECAL.**

**NOTICE:** Once used, this kit cannot be returned to the store. If you have a warranty claim, please read and follow Warranty Information directions below.

### **WARRANTY INFORMATION**

CLAM OUTDOORS INC. warrants to the original retail purchaser its product be free from manufacturers defects for one (3) year from the date of the original purchase. Clam Outdoors Inc will replace or repair any part found defective within the one (3) year time limit. All parts must be returned to Clam Outdoors Inc. Before returning any parts, you must first call or write and acquire a return authorization. All returns must be returned postage-prepaid and include the original cash register receipt (date and purchase price).

#### **To submit a warranty claim request, please use one of the following methods:**

- Customer Service Hrs: 9am to 4pm, Monday – Friday Central Standard Time
- Clam Corporation  
Attn: Customer Service – Warranty Department  
12135 Brockton Lane  
Rogers, MN 55369
- Phone: 763-231-4120
- Fax: 763-231-4121
- Email: [customerservice@clamcorp.com](mailto:customerservice@clamcorp.com)
- Website: [Clamoutdoors.com](http://Clamoutdoors.com)

The warranty does not apply to any Polar Trailer accessory which has been subjected to an accident, improper installation, modification, adjustment, repair, misuse, misapplication, neglect, including but not limited to improper maintenance, or use of unauthorized parts or attachments.

### **LIMITATION OF LIABILITY**

It is expressly understood that Clam Outdoors Inc. liability for its products, whether due to breach of warranty, negligence, strict liability, or otherwise, is limited to the repair of the product as stated above. Clam Outdoor Inc. is not liable for any injury, loss, damage, or expense, whether direct or consequential, including but not limited to loss of use, income, profit, or damage to material arising in connection with the sale, installation, use of, inability to use, or the repair or replacement of Clam Outdoor Inc. products. Clam Outdoor Inc. reserves the right to make alterations or modifications in its products at any time, which in its opinion, may improve the performance and efficiency of the product. It shall not be obligated to make such alterations or modifications to products already in service.



**THE FOLLOWING STATEMENTS ARE SUGGESTIONS AND DO NOT SUPERCEDE OR ELIMINATE ANY TOWING AND SAFETY INSTRUCTIONS LISTED IN ANY OWNERS MANUALS FOR ANY PRODUCT BEING USED FOR THE PURPOSE OF TOWING ANY CLAM OUTDOORS INC. PRODUCTS. ALWAYS REFER TO THE TOWING VEHICLES MANUAL, GUIDELINES OR INSTRUCTIONS.**

#### **Towing Loads Safely**

- Stopping distance increases with speed and weight of towed load. Travel slowly and allow extra time and distance to stop.
- Total towed weight must not exceed limits specified in towing vehicle operator's manual.
- Excessive towed load can cause loss of traction and loss of control on slopes. Reduce towed weight when operating on slopes.
- Never allow children or others in or on towed equipment.
- Use only approved hitches. Tow only with a machine that has a hitch designed for towing. Do not attach towed equipment except at the approved hitch point.
- Follow the manufacturer's recommendations for weight limits for towed equipment and towing on slopes.
- Do not turn sharply. Use additional caution when turning or operating under adverse surface conditions. Use care when reversing.
- Do not shift to neutral and coast downhill.
- 

#### **Protect Bystanders**

- Keep bystanders away when you operate a towed attachment.
- Before you back machine and attachment, look carefully behind attachment for bystanders.

#### **Keep Riders off Towed Attachment**

- Keep riders off of a towed attachment.
- Riders on a towed attachment are subject to injury, such as being struck by objects and being thrown off the attachment during sudden starts, stops and turns.
- Riders obstruct the operator's view, resulting in the attachment being used in an unsafe manner.
- Keep riders off of the hitch bracket or trailer tongue.

## **KIT CONTENTS:**

<b>QTY</b>	<b>PART NO.</b>	<b>DESCRIPTION</b>
2	101999	BRACKET, CORNER CONNECT
1	102001	WELDT, LRG RH RAIL
1	102003	WELDT, LRG LH RAIL
1	102005	WELDT, LRG FRONT RAIL
1	104873	INSTRUCTIONS, LRG TRAILER, RAIL KIT
1	104874	KIT, HDWR, SIDE RAIL
6	101899	NUT, 5/16-18 NYLOCK
6	102009	BOLT, 5/16-18 X 2.25 TH GR5
8	102019	BOLT, 5/16-18 X 1.50 PTH GR5 CZ
6	102035	WASHER, 5/16 WIDE FLAT

**!** RAIL SYSTEM CAN BE ASSEMBLED WITH SCREEN SIDES FACING INSIDE OR FACING OUTSIDE OF TRAILER. THIS ASSEMBLY IS SHOWING MESH SIDES FACING INWARD

## STEP 1 - FRONT RAIL

- A) CONNECT FRONT RAIL (102005) TO CORNER BRACKET (101999) WITH SCREWS (102019) AS SHOWN.
- B) CONNECT OTHER CORNER BRACKET (101999) TO OTHER END OF FRONT RAIL (102005) WITH SCREWS (102019).

**!** LOOSELY ASSEMBLY ALL COMPONENTS IN THIS STEP.

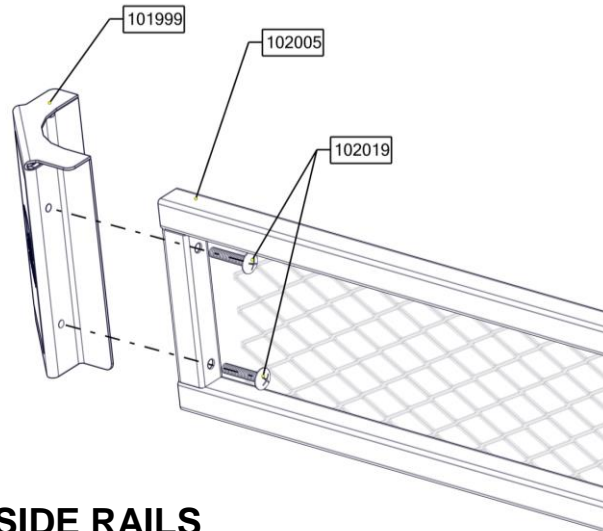

## STEP 2 - ADDING SIDE RAILS

- A) CONNECT CORNER BRACKET (101999) TO RIGHT HAND RAIL (102001) WITH SCREWS (102019) AS SHOWN.
- B) CONNECT OTHER CORNER BRACKET (101999) TO LEFT HAND RAIL (102003) WITH SCREWS (102019).

**!** LOOSELY ASSEMBLY ALL COMPONENTS IN THIS STEP.

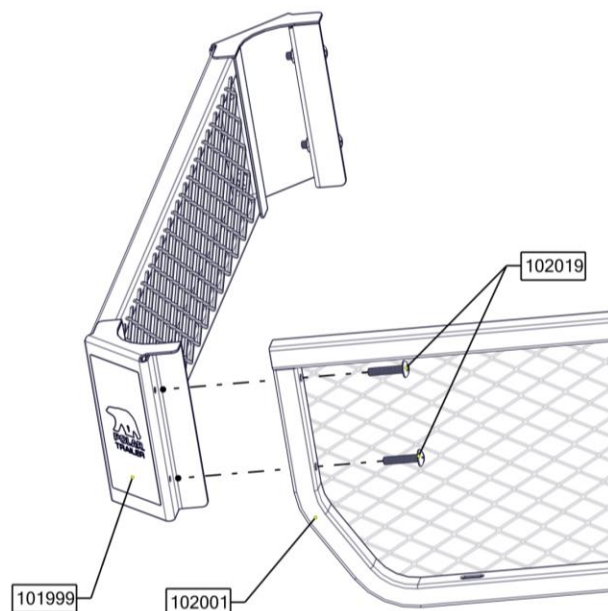

## STEP 3 - ATTACHING RAIL SYSTEM

- A) REMOVE THE EXISTING SCREWS, WASHERS AND NUTS FROM TOP SIDES OF TRAILER.
- B) PLACE THE **LOOSELY** ASSEMBLED RAIL SYSTEM IN PLACE AND **LOOSELY** ASSEMBLY SIDE RAILS TO TRAILER USING 1-SCREWS (102009) 1-WASHERS (102035) AND 1-NUTS (101899) CENTERED PER EACH SIDE IN SAME LOCATIONS AS PREVIOUSLY REMOVED FASTENERS.
- C) CLEARLY MARK THE REMAINING HOLES LOCATIONS (2- PER EACH SIDE RAIL) ONTO THE TRAILER USING A MARKER OR SOME SHARP PUNCH TOOL.
- D) REMOVE THE RAIL SYSTEM FROM TRAILER.
- E) DRILL 3/8 DIAMETER HOLES THRU THE TRAILER AT MARKED LOCATIONS.
- F) PLACE RAIL ASSEMBLY BACK ON TRAILER AND FASTEN TO TRAILER USING 3-SCREWS (102009), 3-WASHER (102035) AND 3-NUTS (101899) PER EACH SIDE.

 LOOSELY ASSEMBLY ALL COMPONENTS IN THIS STEP.

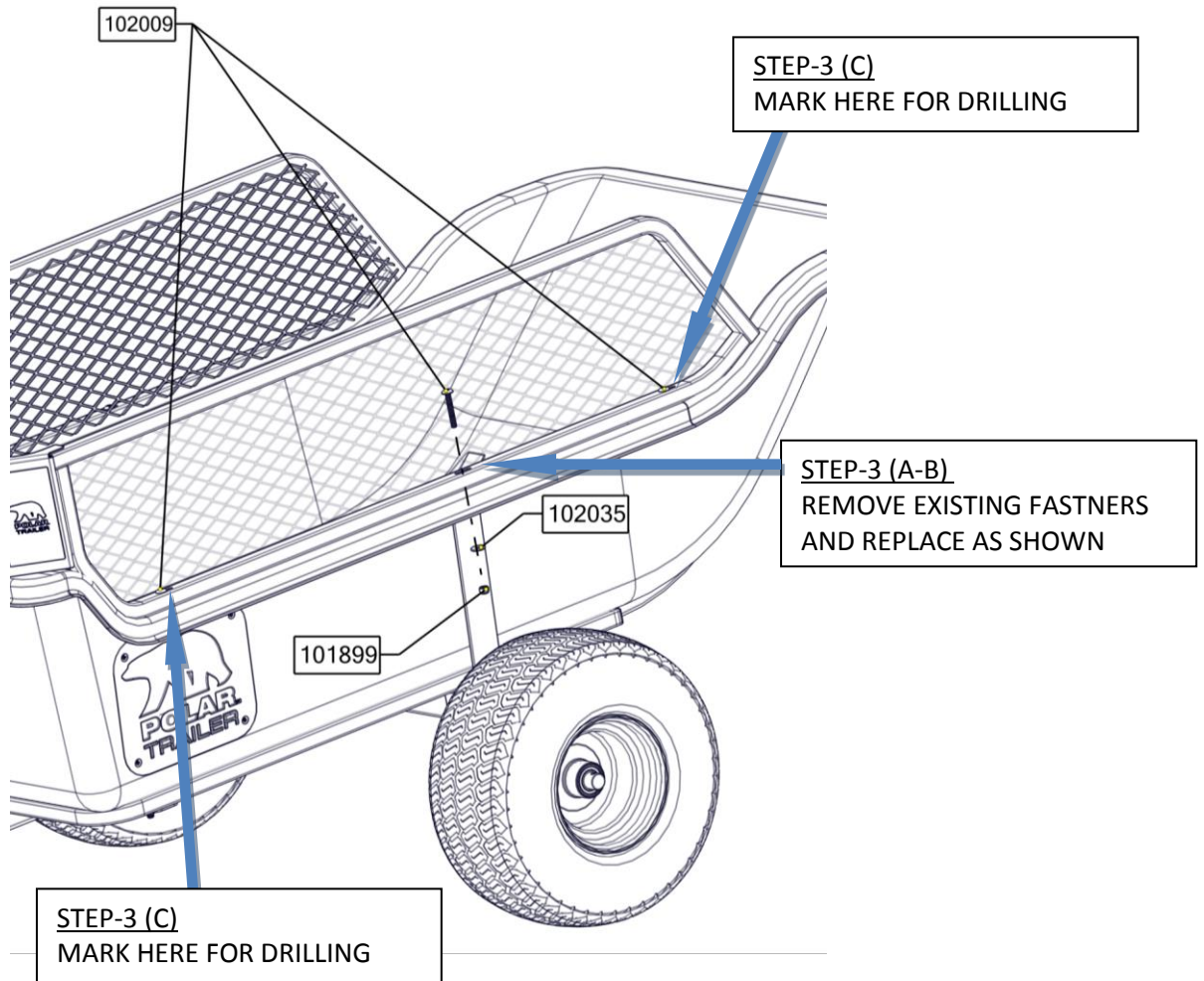

## STEP 4- FINAL ASSEMBLY

A) SECURELY TIGHTEN ALL FASTENERS.

