



Parts Manual

Mfg. No: 040586-00
20,000 Watt Standby Generator (B&S
Fortress)

Model Components	Page
Accessory Group.....	4
Alternator Group.....	6
Control Panel Group.....	8
Decals Group.....	10
Enclosure Group.....	12
Fuel, Duct & Support Group.....	14
Power Group.....	16
Torque Specification Chart.....	18

Not For
In Reproduction

Accessory Group

Note: Unless noted otherwise, use the standard torque specifications

Mfg. No: 040586-00

0010

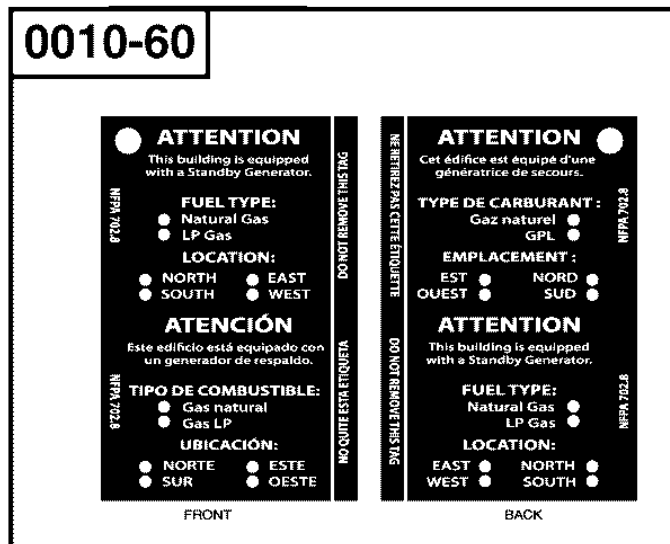
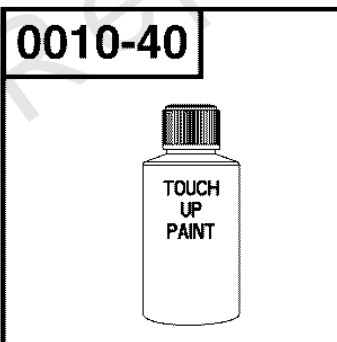
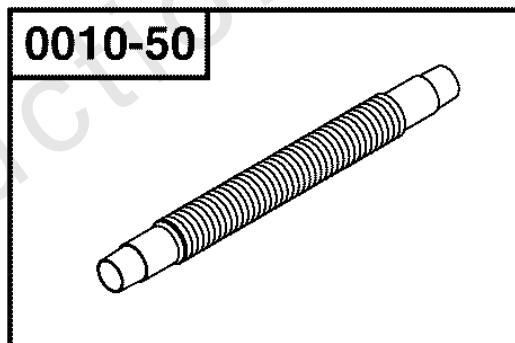
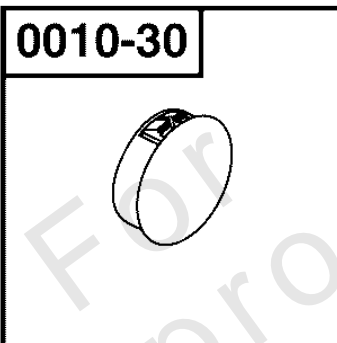
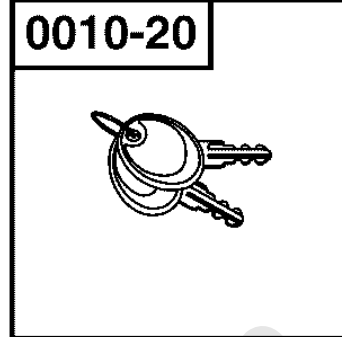
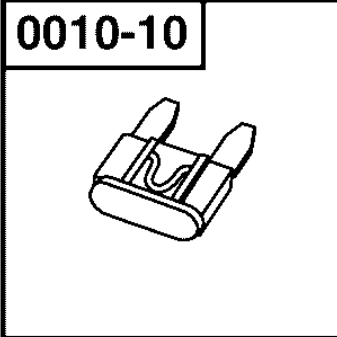

0020

Accessory Group

REF NO	PART NO	QTY	DESCRIPTION
0010	772391	1	KIT, Accessory -(Incl. Ref. Nos. 0010-10, 0010-20, 0010-30, 0010-40, 0010-50, 0010-60)
0010-10	198573GS	2	FUSE, Auto Type, 15 Amp
0010-20	314290GS	1	KEY, Latch
0010-30	198460GS	4	PLUG, Dome
0010-40	772357	1	PAINT, Touch Up, Stone Gray, Texture
0010-50	202295GS	1	HOSE, Flex, NG / LPG
0010-60	706988	1	HANG TAG-ATTN. STANDBY EQUIPMENT
0020	84002283	1	PAINT, Touch Up, Stone Gray, 12 oz. Spray Can
--	314941GS		BATTERY WARMER -(Optional Accessory)

Not For In Reproduction

Alternator Group

Note: Unless noted otherwise, use the standard torque specifications

Mfg. No: 040586-00

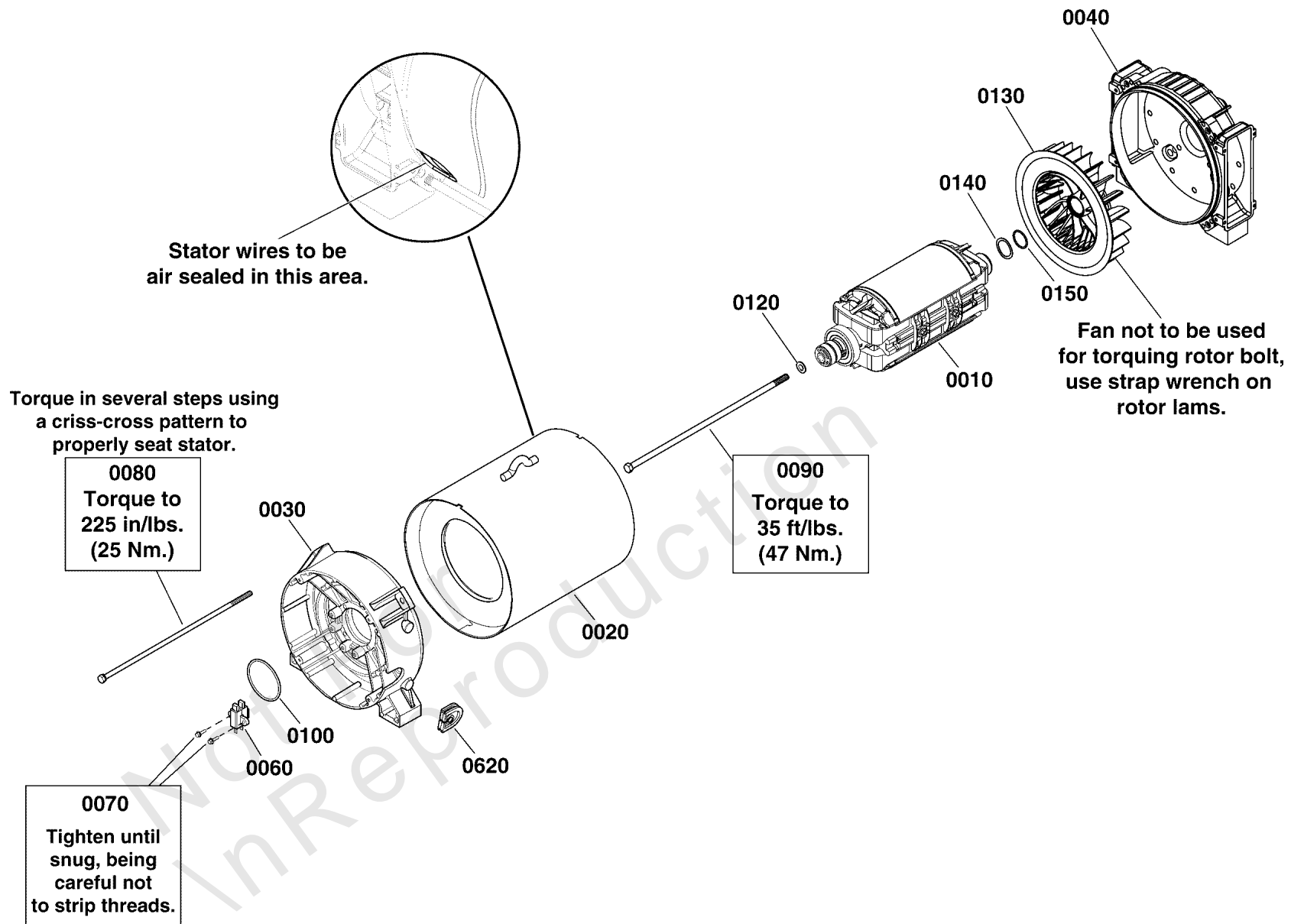

Alternator Group

REF NO	PART NO	QTY	DESCRIPTION
0010	709463		ROTOR
0020	314666GS		STATOR
0030	195234GS		RBC
0040	195235GS		ADAPTER, Engine
0060	66386GS		BRUSH ASSEMBLY
0070	66849GS		TAPTITE
0080	315199GS		SCREW
0090	315204GS		BOLT
0100	199888GS		O-RING
0120	203200GS		WASHER
0130	319105GS		FAN
0140	319110GS		WASHER
0150	319111GS		O-RING
0620	315440GS		GROMMET

Not For In Reproduction

Control Panel Group

Note: Unless noted otherwise, use the standard torque specifications

Mfg. No: 040586-00

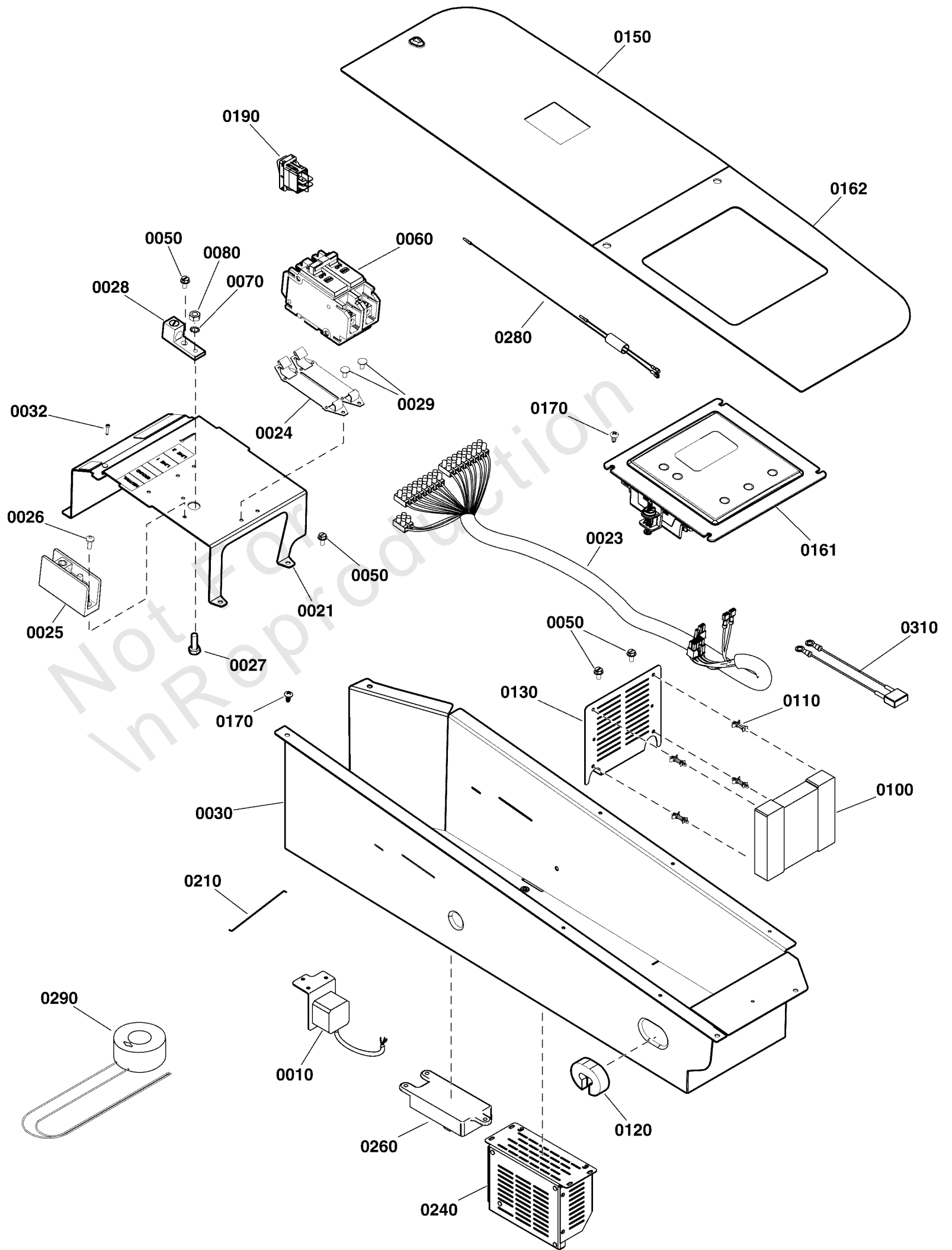

Control Panel Group

REF NO	PART NO	QTY	DESCRIPTION
0010	707181	1	MOTOR, Stepper
0021	-----	1	BRACKET, Breaker
0023	772377	1	HARNESS, Field Connection
0024	192770GS	2	BRACKET, Mounting / Breaker
0025	208365GS	1	BLOCK, Terminal
0026	205947GS	2	SCREW, Trilobular, #10-32 x 3/4
0027	22287GS	1	SCREW, 1/4" - 20 x 3/4"
0028	199011GS	1	LUG, Ground Connect
0029	-----	4	RIVET, Semi Tubular, 5/32 X 1/4
0030	772396	1	ASSEMBLY, Control Box
0032	314691GS	5	SCREW, Taptite, M2.5-.45 X 12
0050	194561GS	17	HHS, Trilobular, #10-32 x 3/8
0060	311318GS	1	BREAKER, Circuit, 100A
0070	26850GS	1	WASHER, Ext. M6 - 1/4" Shakeproof
0080	-----	1	NUT, Hex, 1/4-20
0100	772378	1	ASSEMBLY, Smart AVR
0110	772379	4	SUPPORT, Circuit Board
0120	708727	1	SEAL
0130	772397	1	DIVIDER, Control Box
0150	772398	1	COVER, Circuit Breaker
0161	772373	1	CONTROLLER
0162	772374	1	COVER, Control Panel
0170	315436GS	4	SCREW, #10-16 X 3/8"
0190	772341	1	SWITCH, Rocker
0210	317323GS	1	ROD
0240	772376	1	CHARGER, Battery
0260	772336	1	ASSEMBLY, Relay
0280	772375	1	ASSEMBLY, Sensor, Speed
0290	772339	2	TRANSFORMER, Current, 150:5
0310	84003257	1	ASSEMBLY, Neutral Drain Capacitor

Footnotes:

* Items without part numbers are common fasteners. Purchase locally.

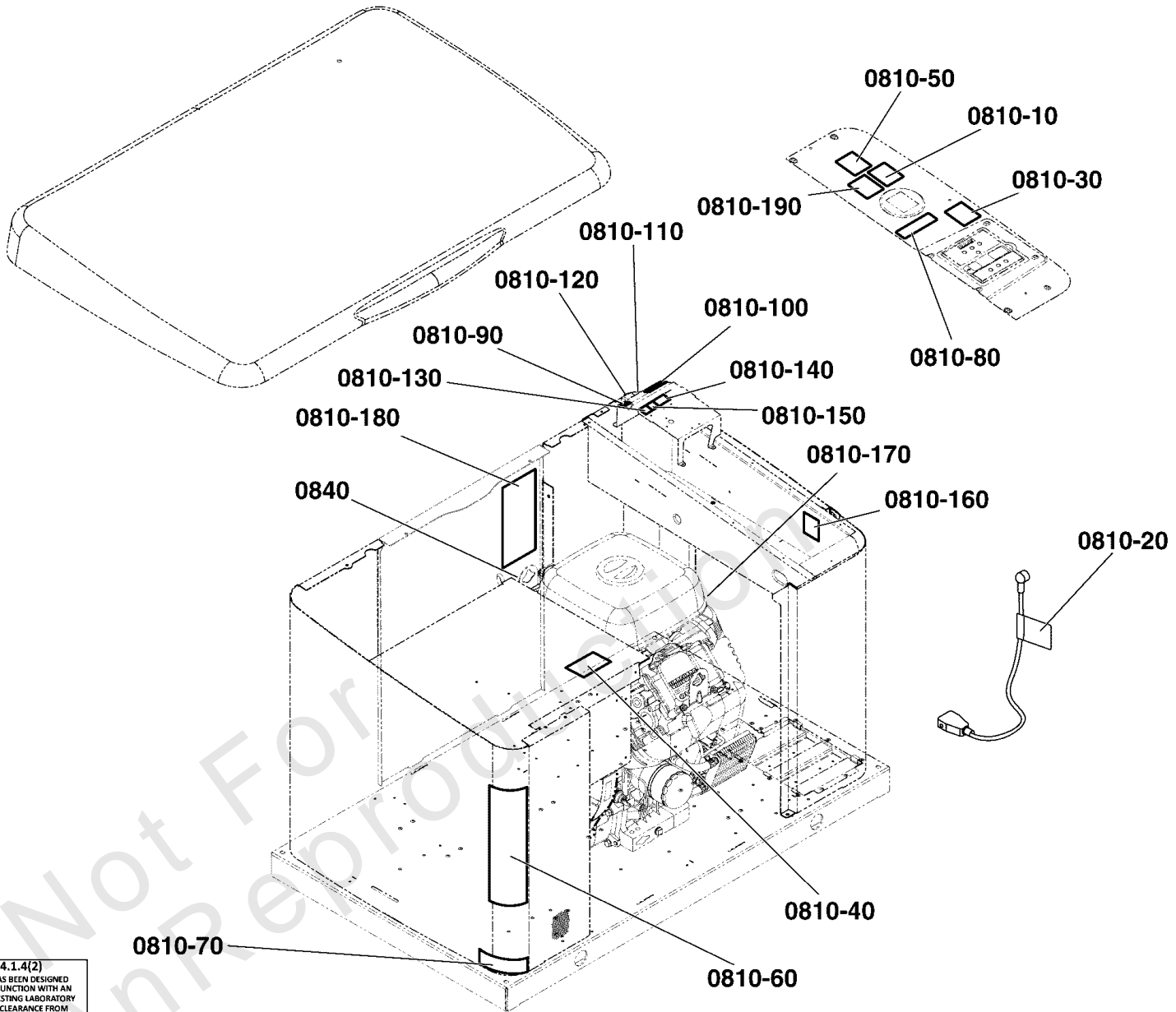

NFPA 37.4.1.4(2)
 THIS GENERATOR HAS BEEN DESIGNED AND TESTED IN CONJUNCTION WITH AN INDEPENDENT FIRE TESTING LABORATORY FOR 18" MINIMUM CLEARANCE FROM COMBUSTIBLE CONSTRUCTION.

0840

0810-10

WARNING AVERTISSEMENT ADVERTENCIA

Risk of electric shock. Do not remove cover. No user serviceable parts inside. Refer servicing to qualified service personnel.

Risque de décharge électrique. Ne pas retirer le couvercle. Aucune pièce à entretenir par l'utilisateur à l'intérieur. Confier l'entretien à du personnel de service qualifié.

Riesgo de descarga eléctrica. No quite la cubierta. No hay partes que puedan ser reparadas por el usuario en el interior. Haga que personal calificado realice el servicio.

0810-20

WARNING AVERTISSEMENT ADVERTENCIA

Explosion of battery gases could result in death or serious injury. Keep all sources of ignition away from battery. Battery contains acid which could result in blindness or severe burns. Avoid contact with acid.

L'explosion des gaz de la batterie peut provoquer des blessures graves, voire la mort. Tenez toutes les sources d'allumage éloignées de la batterie. La batterie contient de l'acide pouvant causer la cécité ou de sévères brûlures. Évitez le contact avec l'acide.

La explosión de la batería podría causar la muerte o lesiones serias. Mantenga todas las fuentes de ignición lejos de la batería. La batería contiene ácido que podría causar ceguera o quemaduras serias. Evite el contacto con el ácido.

0810-30

WARNING AVERTISSEMENT ADVERTENCIA

To reduce the risk of fire, replace only with same type and rating of fuse.

15AMP TYPE ATO

Pour réduire le risque d'incendie, remplacez avec un fusible de même type et classification.

15 A TYPE ATO

Para reducir el riesgo de incendio, reemplazé solamente con un fusible del mismo tipo y capacidad.

15 AMP TIPO ATO

0810-40

WARNING AVERTISSEMENT ADVERTENCIA

Hot surface could result in serious injury. Do not touch.

La surface chaude pourrait entraîner des blessures graves. Ne touchez pas.

La superficie caliente podría causar lesiones serias. No tocar.

0810-50

WARNING AVERTISSEMENT ADVERTENCIA

Engine exhaust contains carbon monoxide, a poisonous gas that could kill you in minutes. You cannot smell it or see it. Install outdoors only. Install carbon monoxide alarms in home. Hot surface could result in serious injury. Do not touch.

Engine exhaust could ignite combustibles resulting in death or serious injury. Exhaust side of weatherproof enclosure shall have 5 ft. (1.5M) min clearance from any structures, awnings, trees or any vegetation.

This equipment may create sparks that could start fires around dry vegetation. A spark arrester may be required. Contact local fire agencies for regulations relating to fire prevention requirements.

L'échappement du moteur contient du monoxyde de carbone, un gaz toxique pouvant tuer en quelques minutes. Vous ne pouvez ni le sentir ni le voir. Installez à l'extérieur seulement. Installez les alarmes de monoxyde de carbone dans la maison.

La surface chaude pourrait entraîner des blessures graves. Ne touchez pas.

L'échappement du moteur peut enflammer les combustibles, ce qui peut provoquer des blessures graves, voire la mort. La partie pour l'échappement de l'équipement à l'extérieur des intempéries doit avoir un dégagement d'au moins 1,5 m (5 pi) de toutes structures, auvents, arbres ou autres végétaux. Cet équipement peut produire des étincelles pouvant déclencher des incendies autour de la végétation sèche. Un pare-étincelles pourrait être nécessaire. Contactez les responsables locaux des incendies pour connaître les exigences réglementaires liées à la prévention des incendies.

Los gases de escape del motor contienen monóxido de carbono, un gas venenoso que podría matarlo en minutos. No puede verlo ni olerlo. Instale solamente en exteriores. Instale alarmas de monóxido de carbono en el hogar.

La superficie caliente podría causar lesiones serias. No tocar.

Los gases de escape del motor podrían incendiar materiales combustibles, lo que podría causar la muerte o lesiones serias. El lado de escape del gabinete impermeable debe tener un espacio libre de 5 pies (1.5 m) de distancia desde cualquier estructura, alero, árbol o cualquier vegetación.

Este equipo puede causar chispas que podrían iniciar incendios en vegetación seca. Podría requerirse un supresor de chispas. Póngase en contacto con las agencias locales de combate a incendios para consultar las regulaciones referentes a requisitos de prevención de incendios.

0810-60

CAUTION MISE EN GARDE PRECAUCION

Connect output of generator to suitably rated transfer switch in accordance with the Canadian Electrical Code, Part 1.

Brancher la sortie de la génératrice à un commutateur convenant de classification convenable, selon le Code canadien de l'électricité, partie 1.

Conecte la salida del generador a un interruptor de transferencia de la capacidad adecuada de acuerdo con el Código Eléctrico Canadiense, Parte 1.

0810-70

RAINPROOF ENCLOSURE / ÉTANCHE À LA PLUIE ENCEINTE / GABINETE A PRUEBA DE LLUVIA

GENERATOR SERVICE DISCONNECT / GÉNÉRATRICE ENTRETIEN DEBRANCHER / DESCONECTOR DE SERVICIO DEL GENERADOR

0810-80

25

25

0810-90

9 +12V W I F I

10 (B)

11 (A)

12 GND

13 +12V C E L L U L A I

14 (B)

15 (A)

16 GND

0810-100

1 +12V

2 GND

3 Xfer

4 2-WIRE START

5

6 E-STOP

7

8 0002987

0810-110

WARNING AVERTISSEMENT ADVERTENCIA

Cancer and Reproductive Harm

www.P65Warnings.ca.gov

Cancer et Troubles de l'Appareil Reproducteur

www.P65Warnings.ca.gov

Cáncer y Problemas Reproductivos

www.P65Warnings.ca.gov

0810-120

240 V-

240 V-

0810-130

(N)

0810-140

(L1)

(L2)

0810-150

(L)

0810-160

0810-170

0810-180

WARNING AVERTISSEMENT ADVERTENCIA

Generator starts automatically which could result in serious injury. Place switch in off and disconnect battery prior to servicing.

La génératrice démarre automatiquement, ce qui pourrait entraîner des blessures graves. Placez le commutateur en position arrêt et débranchez la batterie avant d'effectuer un entretien.

El generador arranca automáticamente, lo que podría causar lesiones serias. Coloque el interruptor en apagado y desconecte la batería antes de realizar algún servicio.

0810-190

NOTICE AVIS

FUEL REQUIREMENTS

Estimated generator fuel supply requirements for both natural gas and LP vapor:

EXIGENCES EN MATIÈRE DE CARBURANT

Approvisionnement approximatif en carburant pour le gaz naturel et le propane gazeux.

REQUERIMIENTOS DE COMBUSTIBLE

Requerimientos estimados de combustible para el generador para gas natural y gas LP.

Natural Gas Gaz naturel Gas natural	LP Vapor Propane gazeux Gas LP	
	BTU/H m3/h	BTU/H m3/h
8KW	121,000	3.43
10KW	169,000	4.79
12KW	172,000	4.86
17KW	248,000	7.02
20KW	280,000	7.36

Fuel inlet pressure requirements at full load are:

FUEL TYPE	Inches of WC	mm of WC
Natural Gas	3.5-7	89-178
LP Vapor	11-14	279-356

Los requerimientos de presión de admisión de carburant a plein rendement sont:

Los requerimientos de presión de entrada de combustible a carga completa son de:

Decals Group

REF NO	PART NO	QTY	DESCRIPTION
0810	84002195	1	DECAL SHEET - WARNINGS -(Includes items 0810-0010 thru 0810-0190)
0810-10	-----	1	DECAL-WARNING, SHOCK
0810-20	-----	1	DECAL, Warning, Battery
0810-30	-----	1	DECAL-WARNING, FUSE
0810-40	-----	1	DECAL-WARNING, HOT SURFACE
0810-50	-----	1	DECAL, Warning, Manual
0810-60	-----	1	DECAL-WARNING, EXHAUST
0810-70	-----	1	DECAL-RAINPROOF ENCLOSURE
0810-80	-----	1	DECAL-DISCONNECT
0810-90	-----	1	DECAL-TERMINAL, 25/26
0810-100	-----	1	DECAL, Terminal Strip
0810-110	-----	1	DECAL, Terminal Strip
0810-120	-----	1	DECAL, External Power Switch
0810-130	-----	1	DECAL, Neutral
0810-140	-----	1	DECAL, L1/L2
0810-150	-----	1	DECAL, Ground
0810-160	-----	1	DECAL, Warning -(The installation of this decal is required for units manufactured after 08/30/2018 and sold in the state of California.)
0810-170	-----	2	DECAL, 240 VAC
0810-180	-----	1	DECAL, Notice Fuel Requirements
0810-190	-----	1	DECAL, Warning
0840	-----	1	DECAL, Clearance From Combustible Construction

Enclosure Group

Note: Unless noted otherwise, use the standard torque specifications

Mfg. No: 040586-00

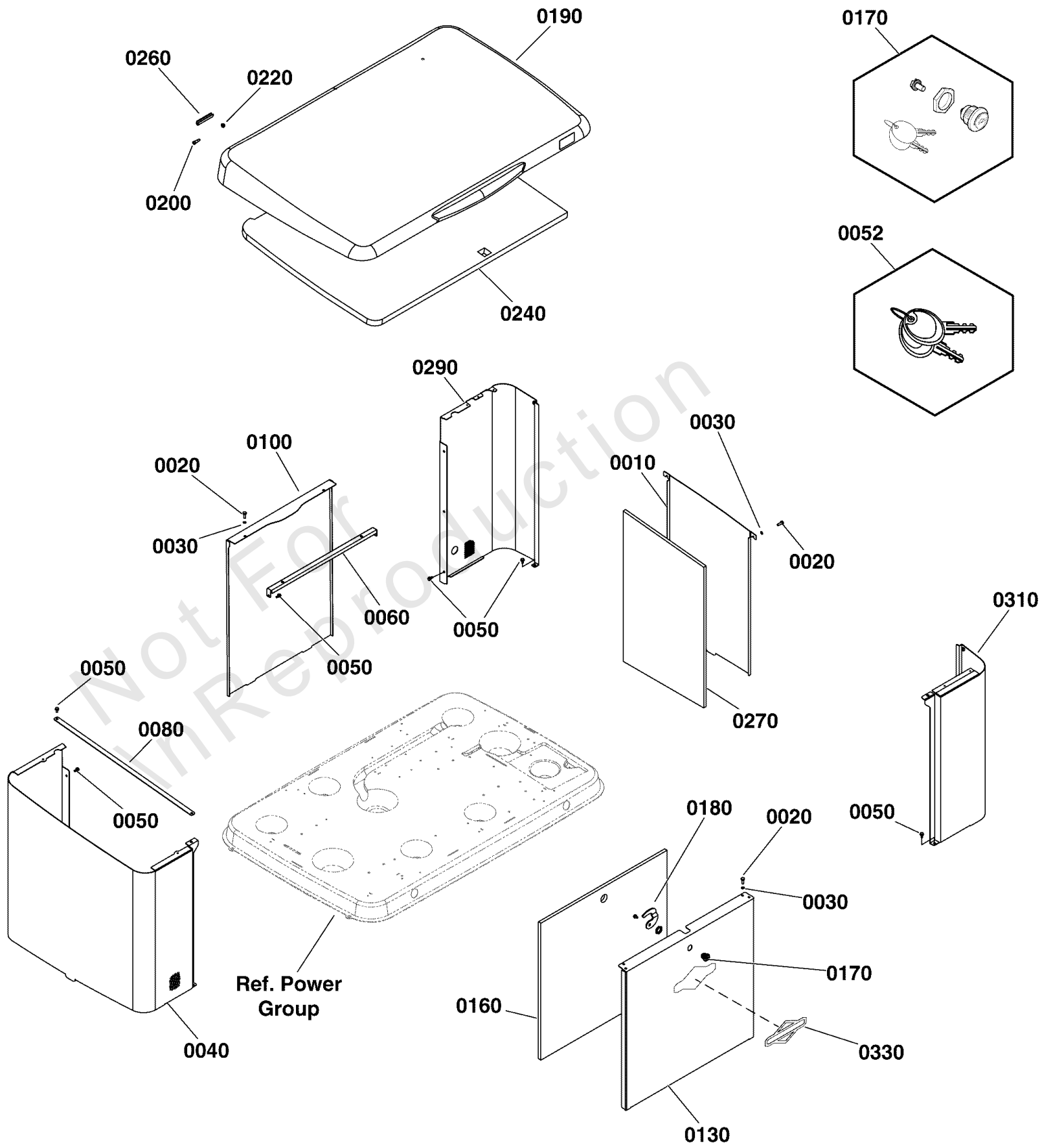

Enclosure Group

REF NO	PART NO	QTY	DESCRIPTION
0010	772384	1	PANEL, End, Right
0020	22287GS	6	SCREW, 1/4" - 20 x 3/4"
0030	26850GS	6	WASHER, Ext. M6 - 1/4" Shakeproof
0040	772385	1	PANEL, End, Left
0050	80002738YP	12	SCREW, 1/4-20X.500, Hex HD, Self-Tap, Zinc/Clear
0052	314290GS	1	KEY, Latch
0060	314652GS	1	SUPPORT, Rail
0080	314638GS	1	SUPPORT, Rail
0100	772386	1	PANEL, Back
0130	772395	1	PANEL, Front
0160	315447GS	1	INSULATION
0170	314619GS	1	LATCH
0180	315443GS	1	LATCH, Arm
0190	772388	1	ROOF
0200	311644GS	4	SCREW, 5/16-18 x 1/2
0220	194005GS	4	Nut, 1/4 - 20, Flange, Nylok
0240	315452GS	1	INSULATION
0250	316193GS	1	PLUG, Roof -(Not Illustrated)
0260	316954GS	2	TRIM
0270	315453GS	1	INSULATION
0290	772389	1	PANEL, Right End, Back
0310	772390	1	PANEL, Right End
0330	770025	1	DECAL

Fuel, Duct & Support Group

REF NO	PART NO	QTY	DESCRIPTION
0012	314620GS	1	PANEL, Muffler, Bottom
0013	314621GS	1	PANEL, Muffler, Top
0015	314624GS	1	PANEL, Muffler
0018	318771GS	1	DEFLECTOR, Muffler
0020	704130	28	SCREW, Hex Head, 1/4-20 X 1/2
0030	194005GS	3	Nut, 1/4 - 20, Flange, Nylok
0035	314679GS	1	BRACKET, Roof Support
0060	314672GS	1	BRACE
0061	316202GS	1	TRIM
0090	314649GS	2	SHOCK, Roof
0110	311644GS	2	SCREW, 5/16 x 1/2
0115	314647GS	1	BRACKET, Roof Support
0140	314646GS	1	BRACE
0230	318880GS	1	SOLENOID
0300	314662GS	1	TUBE
0350	314626GS	1	DUCT, Alternator
0351	311692GS	1	SEAL
0352	315454GS	1	SEAL
0440	314684GS	1	PANEL, Intake, Alternator
0445	314682GS	1	SEAL
0450	314661GS	5	CLIP
0460	314625GS	7	SUPPORT
0560	314683GS	1	PANEL, Intake, Engine
0562	315444GS	1	SUPPORT
0610	316951GS	1	SEAL
0620	314642GS	1	SNORKEL
0630	314628GS	2	DUCT
0640	74908GS	8	SCREW, M5-0.8 x 10, Taptite
0680	316194GS	1	SCREEN
0690	194561GS	4	SCREW, #10-32 x 3/8
0770	318459GS	1	FITTING
0820	771014	1	FUEL REGULATOR ASSEMBLY -(Includes Ref. Nos. 0820-1, 0820-2, 0820-3, 0820-4, 0820-5, 0820-6, 0820-8, 0820-9 & 0820-10)
0820-1	38750GS	2	HHCS, M6 - 1.0 x 30
0820-2	49813	2	NUT, Hex - M6 - 1.00
0820-3	312781GS	1	ELBOW
0820-4	206976GS	1	FITTING
0820-5	314693GS	1	FITTING, Barb
0820-6	318002GS	1	FITTING
0820-8	706379	1	BRACKET
0820-9	847105GS	1	REGULATOR, With Valve, LP/NG Selector
0820-10	22097GS	2	WASHER, Lock, Split, 1/4"
0850	71693GS	4	WASHER, Fender, 5/16
--	6358	1	KIT, Fuel Regulator (Low Pressure Applications Only) -(Optional Accessory - Not Included)

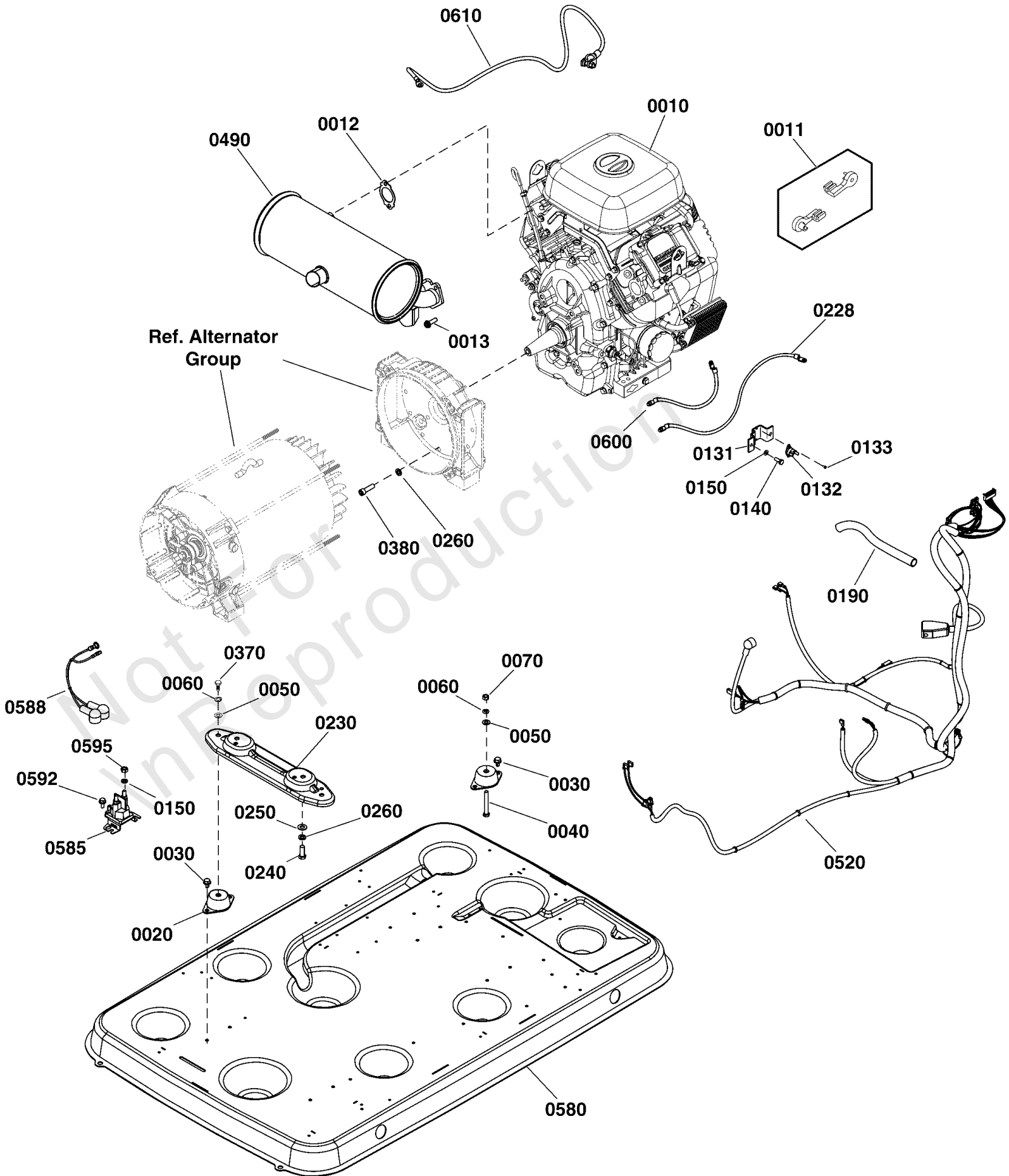

Power Group

REF NO	PART NO	QTY	DESCRIPTION
0010	-----	1	**ENGINE -(**See footnote)
0011	844862	2	Clevis
0012	807208	2	Gasket-Exhaust
0013	-----	4	* SCREW, M8 x 25 -(*See footnote)
0020	187594GS	2	MOUNT, Vibration
0030	24910GS	8	*CAPSCREW, Hex Head, Trilobular, 5/16, 18 x 1/2
0040	-----	2	* CAPSCREW, Hex Head, 5/16-18 x 2-1/2 -(*See footnote)
0050	22145GS	6	WASHER, Flat, 5/16 - M8
0060	22129GP	4	WASHER, 5/16 - M8, Lock
0070	22259GS	2	NUT, 5/16 - 18
0131	313561GS	1	PLATE, Temp Switch
0132	204426GS	1	SWITCH, Temperature
0133	708730	2	SCREW
0140	47411GS	2	SCREW
0150	22097GS	2	WASHER, Lock, Split, 1/4"
0190	5048681SM	1	HOSE, OIL DRAIN
0228	772393	1	CABLE, Ground
0230	B198896GS	1	BRACKET, Mounting Alternator, Black
0240	29745GS	2	HHCS, 3/8" - 16 x 1"
0250	22131GS	2	WASHER, Flat 3/8"
0260	22237GS	6	WASHER, Locking, 3/8
0370	-----	2	CAPSCREW, Hex Head, 5/16-18 x 3/4, G5
0380	23645GS	4	SOCKET HEAD CAP SCREW, 3/8-16 x 1-1/4"
0490	314663GS	1	MUFFLER
0520	772380	1	HARNESS, Wire, Main
0580	706061	1	BASE
0585	772333	1	SOLENOID, Starter
0588	772381	1	HARNESS, Intermediate, Relay
0592	-----	2	SCREW, 1/4-20 x 1/2" Hex Washer Self-Tap, BZ
0595	80002726	2	NUT, 5/16-24, GR5
0600	706527		WIRE, Ground
0610	314640GS	1	WIRE, Battery, Ground

Footnotes:

* Items without part numbers are common fasteners. Purchase locally.

** To verify your specific engine model, please reference the ID Tag located on your engine. See your local Briggs & Stratton distributor for parts and service.

Hardware Identification & Torque Specifications

Torque Specification Chart								
FOR STANDARD METRIC MACHINE HARDWARE (Tolerance ± 20%)								
Property Class	5.6		8.8		10.9		12.9	
	Class 5.6		Class 8.8		Class 10.9		Class 12.9	
Size Of Hardware	in/lbs	Nm.	in/lbs	Nm.	in/lbs	Nm.	in/lbs	Nm.
	ft/lbs		ft/lbs		ft/lbs		ft/lbs	
M3	5.88	.56	13.44	1.28	19.2	1.80	22.92	2.15
M4	13.44	1.28	30.72	2.90	43.44	4.10	52.56	4.95
M5	26.4	2.50	60.96	5.75	5.97	8.10	7.15	9.7
M6	44.64	4.3	7.3	9.9	10.3	14	12.1	16.5
M7	5.2	7.1	12.1	16.5	16.9	23	19.9	27
M8	7.7	10.5	17.7	24	25	34	29	40
M10	15	21	35	48	50	67	59	81
M12	26	36	61	83	86.2	117	103	140
M14	42	58	101	132	136	185	162	220
M16	64	88	147	200	210	285	250	340
M18	89	121	202	275	287	390	346	470
M20	126	171	290	390	405	550	486	660
M22	169	230	390	530	559	745	656	890
M24	217	295	497	375	708	960	840	1140
M27	320	435	733	995	1032	1400	1239	1680
M30	435	590	995	1350	1401	1900	1681	2280
M33	590	800	1349	1830	1902	2580	2278	3090
M36	759	1030	1740	2360	2441	3310	2935	3980
M39	988	1340	2249	3050	3163	4290	3798	5150

Torque Specification Chart						
FOR STANDARD MACHINE HARDWARE (Tolerance ± 20%)						
Hardware Grade	No Marks		SAE Grade 5		SAE Grade 8	
	SAE Grade 2		SAE Grade 5		SAE Grade 8	
Size Of Hardware	in/lbs	Nm.	in/lbs	Nm.	in/lbs	Nm.
	ft/lbs		ft/lbs		ft/lbs	
8-32	19	2.1	30	3.4	41	4.6
8-36	20	2.3	31	3.5	43	4.9
10-24	27	3.1	43	4.9	60	6.8
10-32	31	3.5	49	5.5	68	7.7
1/4-20	66	7.6	8	10.9	12	16.3
1/4-28	76	8.6	10	13.6	14	19.0
5/16-18	11	15.0	17	23.1	25	34.0
5/16-24	12	16.3	19	25.8	29	34.0
3/8-16	20	27.2	30	40.8	45	61.2
3/8-24	23	31.3	35	47.6	50	68.0
7/16-14	30	40.8	50	68.0	70	95.2
7/16-20	35	47.6	55	74.8	80	108.8
1/2-13	50	68.0	75	102.0	110	149.6
1/2-20	55	74.8	90	122.4	120	163.2
9/16-12	65	88.4	110	149.6	150	204.0
9/16-18	75	102.0	120	163.2	170	231.2
5/8-11	90	122.4	150	204.0	220	299.2
5/8-18	100	136	180	244.8	240	326.4
3/4-10	160	217.6	260	353.6	386	525.0
3/4-16	180	244.8	300	408.0	420	571.2
7/8-9	140	190.4	400	544.0	600	816.0
7/8-14	155	210.8	440	598.4	660	897.6
1-8	220	299.2	580	788.8	900	1,244.0
1-12	240	326.4	640	870.4	1,000	1,360.0

The guides and ruler furnished below are designed to help you select the appropriate hardware.



Nut, M8

Thread Diameter (mm)

Inside Diameter (in) Threads per inch

Nut, 1/2-16



Screw, M8- 1.25 x 25

Thread Diameter (mm) Distance between threads (mm) Body Length (mm)

Body Diameter Threads per inch Body Length (in)

Screw, 1/2- 16 x 2



Standard Hardware Sizing

When a washer or nut is identified as 1/2" (M8), this is the *Nominal size*, meaning the *inside diameter* is 1/2 inch (8mm metric thread diameter); if a second number is present it represents the *threads per inch* (distance between threads).

When bolt or capscrew is identified as 1/2 - 16 x 2" (M8 - 1.25 x 50), this means the *Nominal size*, or body diameter is 1/2 inch (8mm metric thread diameter), the second number, 16, represents the *threads per inch*, (*distance between threads*). The final number is the body length of the bolt or screw, 2 inches (50mm).

NOTES

- These torque values are to be used for all hardware excluding: locknuts, self-tapping screws, thread forming screws, sheet metal screws and socket head setscrews.
- Recommended seating torque values for locknuts:
 - for prevailing torque locknuts - use 65% of grade 5 torques.
 - for flange whizlock nuts and screws - use 135% of grade 5 torques.
- Unless otherwise noted on assembly drawings, all torque values must meet this specification.

Common Hardware Types

Hex Head Capscrew



Washer



Carriage Bolt



Hex Nut

Wrench & Fastener Size Guide

1/4" Bolt or Nut Wrench—7/16"	5/16" Bolt or Nut Wrench—1/2"	3/8" Bolt or Nut Wrench—9/16"	7/16" Bolt or Nut Wrench (Bolt)—5/8" Wrench (Nut)—11/16"	1/2" Bolt or Nut Wrench—3/4"
M6 Bolt or Nut Wrench—10mm	M8 Bolt or Nut Wrench—13mm	M10 Bolt or Nut Wrench—17mm	M12 Bolt or Nut Wrench—19mm	M14 Bolt or Nut Wrench—22mm

