

WARRANTY

We strive to offer high-quality products, and we also try our best to satisfy each and every customer that orders from us with product or service as needed. We provide 30 days warranty starting from the time you receive the item. Each customer must provide a record of their order such as the order number, or item receipt for any items that are out of the warranty period you may also still receive replacement parts by purchasing them with our company if they are available.

**Are you having difficulty
with assembly? Missing parts?**

**PLEASE DON' T RETURN THE ITEM TO
RETAILER**

For help call or email with your order No.

Customer service:

888-214-6610

Open Monday through Friday

9:00AM-5:00PM CST

Email:

customerservice@hulalahome.com

24h

HULALA
H O M E

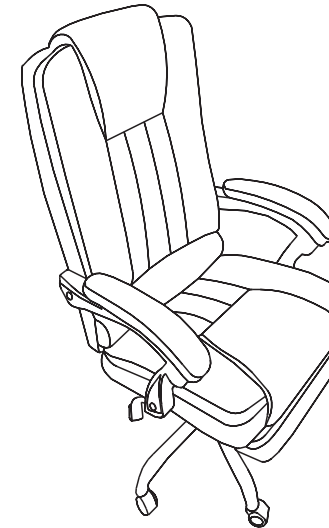

ITEM NO. OFA0086

NOTE:

This brochure contains IMPORTANT safety info. Please read and keep for future reference.

MAINTAINANCE AND WARNING

- Keep furniture away from heat.
- Do not clean furniture with harsh cleansers or polish. Do not use detergents, Solvents, abrasives, spray packs or leather cleaner. Use non-color mild soap with warm water clean spills(Mix 1:10 soap to water)
- Do not place furniture under direct sunlight, material will possibly fade over time.
- Do not use on site dry Cleaning machine.
- Children should not climb or jump on the furniture.
- Do not write on furniture without a padded barrier to protect the surface.
- To obtain the longest lifespan of your outdoor products, avoid exposure to rain or snow, and direct sunshine for long time. Whenever possible cover the product and/or place under patio or awnings.
- Not for commercial use, For residential use only.



Weight Limitation

220LBS

PARTS LIST

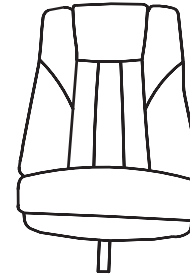

BACK A

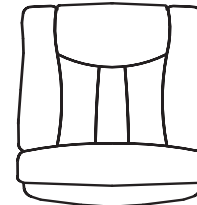

SEAT B

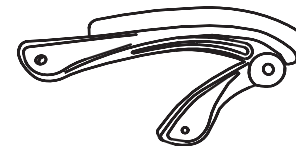

LEFT ARM 1 PC C

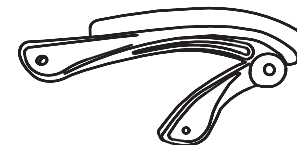

RIGHT ARM 1 PC D



Estimated Duration Of Assembly

5-10 MINUTES

HARDWARE LIST



MECHANISM 1 PC E

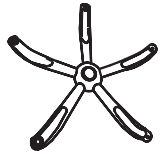

BASE 1 PC F



GASLIFT 1 PC G

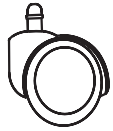

GASTER 5 PC H



SCREW 5 PCS I
(1pc extra screw includes)



SCREW 5 PCS J
(1pc extra screw includes)



CAP 4 PCS K



ALLEN KEY 1 PC L

Be sure to check all packing material carefully for small parts, which may have come loose inside the carton during shipment.

ASSEMBLY INSTRUCTIONS

STEP 1 Insert caster H to bottom of spider base F then insert gas lift G to center hole of the spider base F.

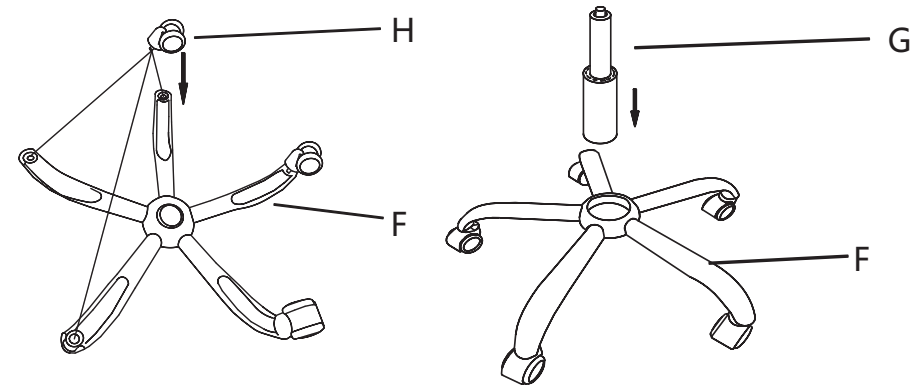

STEP 2 Use bolt I, allen key L to attach mechanism E to bottom of seat B, make sure it all align then fasten bolts to secure.

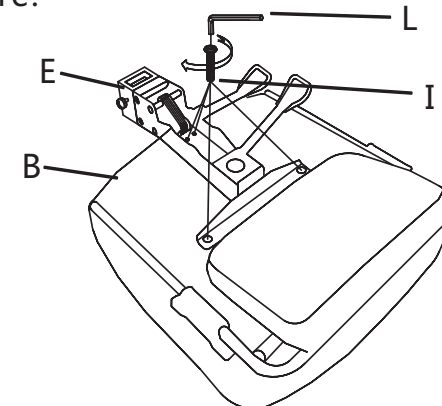

STEP 3 Align and insert gas lift G with bottom hole of mechanism E, press to secure.

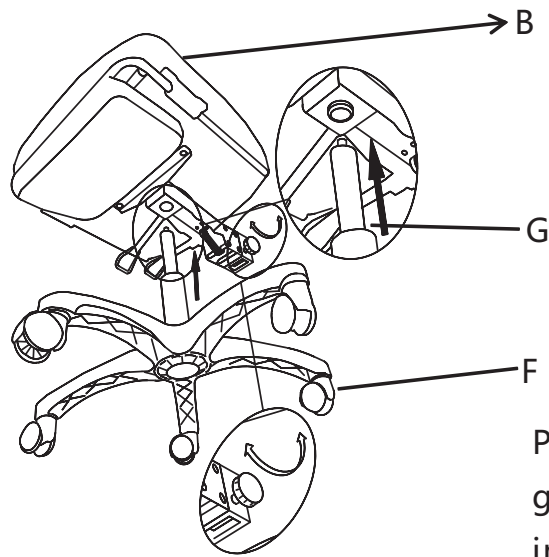

Please tighten the gear handle after insert back rest.

STEP 4 Insert the back rest A to rear hole of seat B

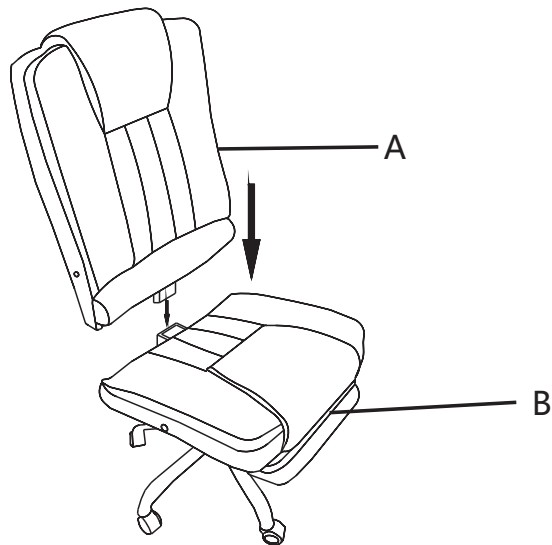

5

STEP 5 Use bolt J, allen key L to attach armrest C to side of seat B and backrest A, make sure it all align then fasten bolts to secure. Attach cap K to cover screw holes.

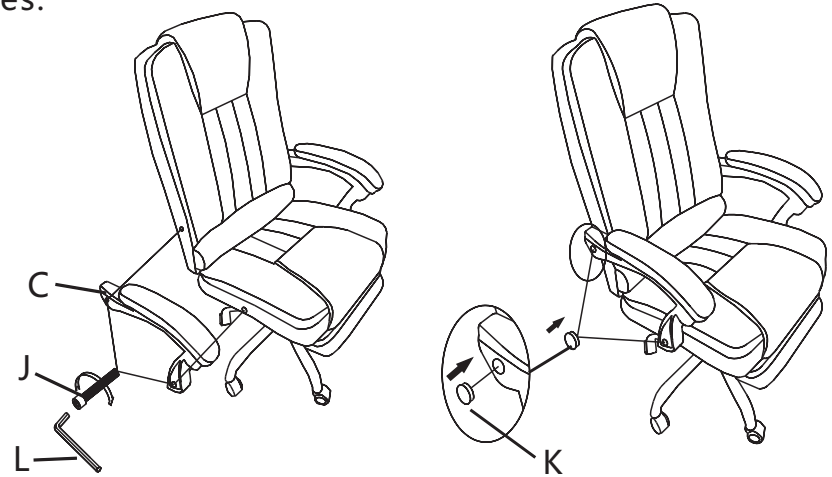

STEP 6 Assembly completed.

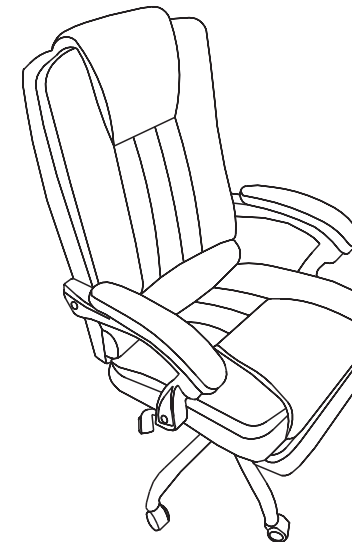

6