

Makita[®]

DOLMAR[®]

REPAIR MANUAL

BHX2500
BHX2500CA
PB-251.4

CONTENTS

I . SPECIFICATIONS	2
1. SPECIFICATIONS	2
2. PART NAMES	3
II . PREPARATIONS	4
1. PREPARATIONS	4
2. NOTICE	4
3. SPECIAL TOOL FOR DISASSEMBLY	4
III . DISASSEMBLY AND REASSEMBLY PROCEDURE .	5
1. EQUIPMENT DISASSEMBLY	5
2. EQUIPMENT REASSEMBLY	7 ~ 11
3. ENGINE DISASSEMBLY	12
4. ENGINE REASSEMBLY	13 ~ 25
5. CARBURETOR DISASSEMBLY AND REASSEMBLY .	26 ~ 27
6. STARTER DISASSEMBLY AND REASSEMBLY . . .	28 ~ 30
IV . MALFUNCTION AND REPAIRE	31 ~ 32
V . CHECK AND RECONDITIONING	33
VI . CRITERIA FOR RECONDITIONING	34 ~ 35
VII . NOTICE	36
VIII . CARE AND STORAGE	37
IX . CHECK, DRAINAGE AND FEEDING OF ENGINE OIL . .	38

I . SPECIFICATIONS

1. SPECIFICATIONS

SPECIFICATIONS		
Product Name	Engine Blower	
Type	BHX2500/PB250.4	
Dimensions (LXWXH) mm	350×231×368 (13.8×9.1×14.5 in only for body)	
Dry Weight kg	4.5 (9.5 lbs only for body)	
Engine	Model	EH025F
	Type	Air-Cooled, 4-Stroke, Upright Single-Cylinder OHV Gasoline Engine
	Piston Displacement mL	24.5 (1.49 cu, in)
	Fuel	Automotive Unleaded Gasoline
	Fuel Tank Capacity L	0.52 (17.6 fl.oz)
	Engine Oil	Automotive Oil SAE 10W-30; Class SF or higher (Automotive 4-Cycle Engine Oil)
	Capacity of Engine Oil L	0.08 (2.7 fl.oz)
	Carburetor	Diaphragm Type
	Ignition System	Breakerless Magneto
	Spark Plug	NGK CMR6A (Type C)
	Starting System	Recoil Starter (with decompression)
	Lubrication	Forced Lubrication
Performance	Max Air Volume m ³ /min	10.1 (356 cu.ft/min)
	Max Air Velocity m/s	64.6 (212 ft/s)
Operating Part	Handle	Volute Case Integrated Loop Handle (with rubber grip)
	Engine Speed Control Lever	Trigger Lever, Cruise Control Lever
Standard Accessories	One Blower Nozzle (Round), One Blower Tube, Tool (Box Wrench) Instruction Manual	

2. PART NAMES

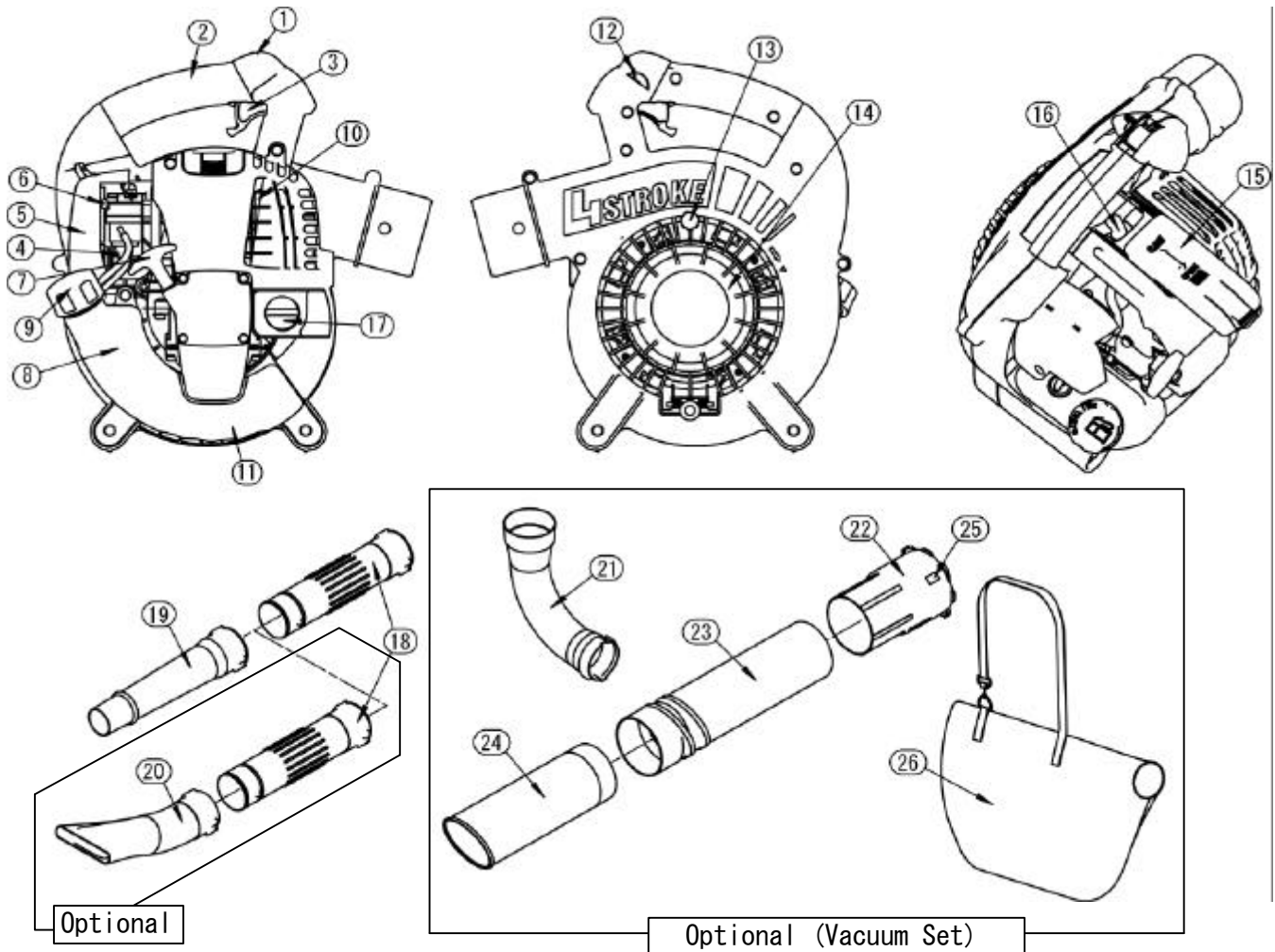

DESIGNATION OF PARTS	DESIGNATION OF PARTS	DESIGNATION OF PARTS	DESIGNATION OF PARTS
1. Stop switch	8. Fuel Tank	15. Plug Cover	22. Vacuum Pipe A
2. Main Handle	9. Fuel Tank Cap	16. Spark Plug	23. Vacuum Pipe B
3. Trigger Lever	10. Muffler	17. Oil Cap	24. Vacuum Pipe C
4. Primer Pump	11. Assist Handle	18. Blower Tube	25. Arrow Mark
5. Air Cleaner Cover	12. Cruise lever	19. Blower Nozzle A	26. Dust Bag
6. Choke Lever	13. Screw	20. Blower Nozzle B	
7. Starter Handle	14. Protector	21. Elbow	

II . PREPARATIONS

1. PREPARATIONS

- (1) Workbench
- (2) Tool for disassembly and reassembly
- (3) Wash-pan
- (4) Wash oil (light oil, gasoline, etc)
- (5) Automotive 4-stroke engine oil, grease
- (6) Liquid packing
- (7) File, sand paper
- (8) Waste

2. NOTICE

- (1) Use the standard tools properly.
- (2) While disassembling the engine blower, memorize the locations of individual parts so that they can be reassembled correctly.
Attach a tag to a part you are uncertain about its mounting position.
- (3) Use boxes for keeping disassembled parts in a group.
- (4) To prevent any loss and wrong reassembly of screw bolts and nuts, try to assemble each group of disassemble parts temporarily.
- (5) Handle disassembled parts carefully, and clean them with wash oil.
- (6) After removing gaskets, remove extraneous material clearly from the gasket placed palaces.
- (7) Use an impact driver for a screw bolt and screw, etc. that are difficult to be unfastened.
- (8) Use new gaskets when reassembling.
- (9) After reassembling each of the rotatable main parts, rotate by hand to test it for bad movements and abnormal noises.
- (10) After the completion of reassembly, rotate the rotatable main parts by hand to test them for defects and looseness.

3. SPECIAL TOOL FOR DISASSEMBLY

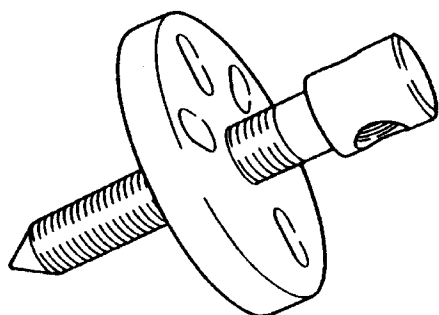

Part number : 5609002000
Tool name : TOOL
Work : Flywheel Puller

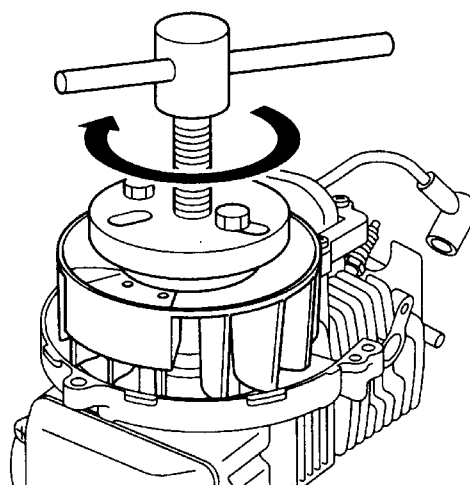

III. DISASSEMBLY AND REASSEMBLY PROCEDURE

1. EQUIPMENT DISASSEMBLY

Step	Part of remove	Procedure	Fastener	PCS	Notice	Special tool
1	ENGINE OIL	1) Unscrew the CAP, OIL.			Keep contamination or dust off the CAP, OIL and gauge.	
		2) Drain the engine oil.				
		3) Screw the CAP, OIL onto the oil tank.				
2	FUEL	1) Drain the fuel.			The fuel will spout if the fuel tube is removed with the fuel tank filled with fuel.	
		2) Remove the fuel tube.				
3	COVER, AIR CLEANER	1) Remove the COVER, AIR CLEANER.	M5X14mm	1	Keep contaminant or dust off the AIR CLEANER ELEMENT.	
		2) Remove the AIR CLEANER ELEMENT.				
4	COVER, ENGINE	1) Remove the GUARD, OIL.				
		2) Remove the COVER, ENGINE.	5X16mm M4X16mm	3 2		
5	CASE 1, VOLUTE	1) Remove the CASE 1, VOLUTE.	5X16mm	10		
		2) Remove the GRIP.				
		3) Remove the PROTECTOR.	Urea screw 5X16mm	1 1		
		4) Remove the CRUISE CONTROL LEVER.	4X16mm	1		
		5) Remove the LEVER, THROTTLE.				
		6) Remove the CONTROL CABLE.				
		7) Remove the WIRE.				
		8) Remove the STOP SWITCH.				
		9) Remove the RUBBER, FRICTION.				
6	ENGINE	1) Remove the IMPELLER.	M6X20mm	2		
		2) Remove the engine.	M5X30mm	3		
7	TANK, FUEL	1) Remove the TANK, FUEL.	5X16mm	3		

Deal Drawing of Equipment

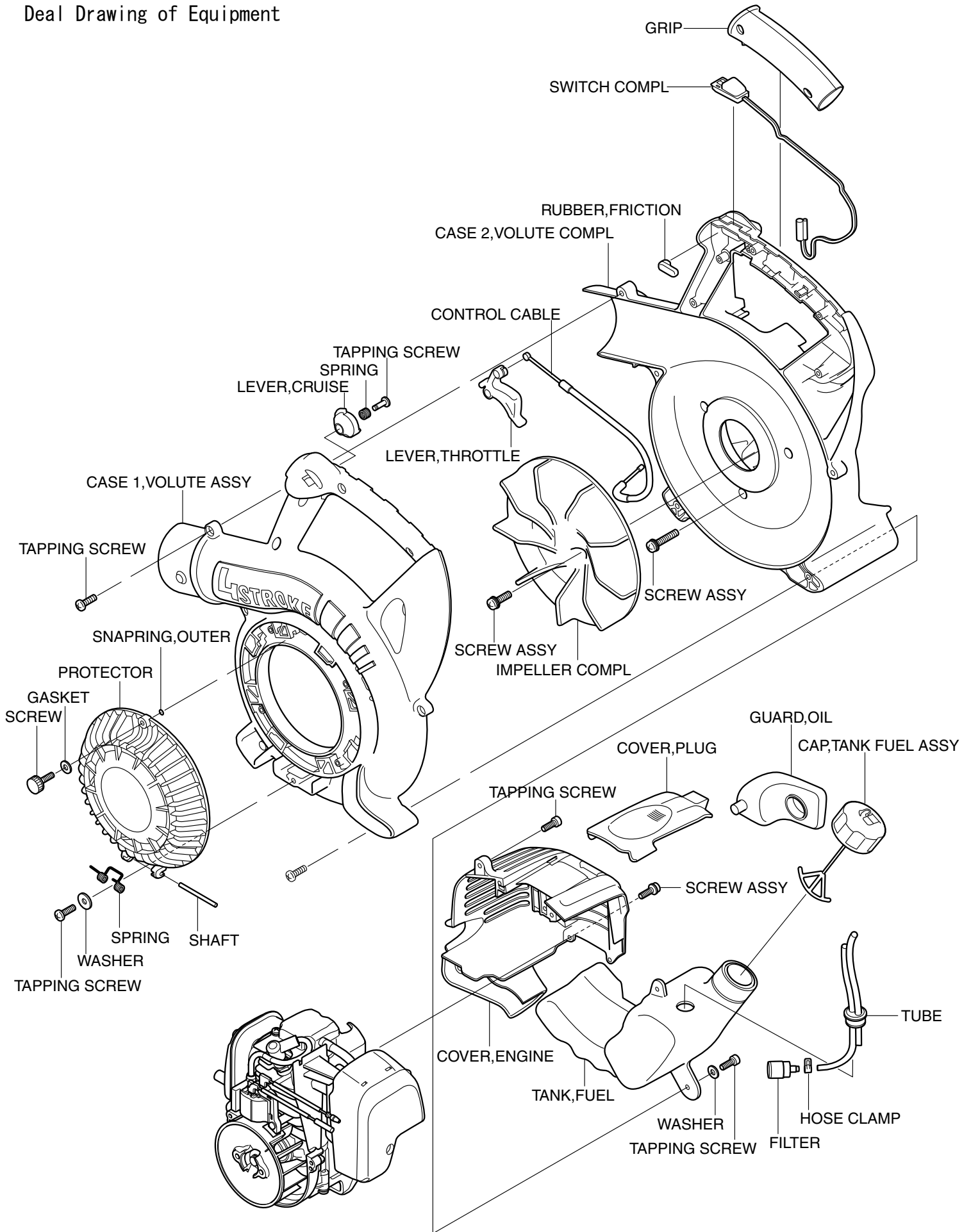

2. EQUIPMENT REASSEMBLY

Equipment reassembly procedure





1. Notice

- Clean parts completely.
- Replace screws with new ones if necessary.
- Tighten up the tightening torque specified parts according to the specified tightening torque.

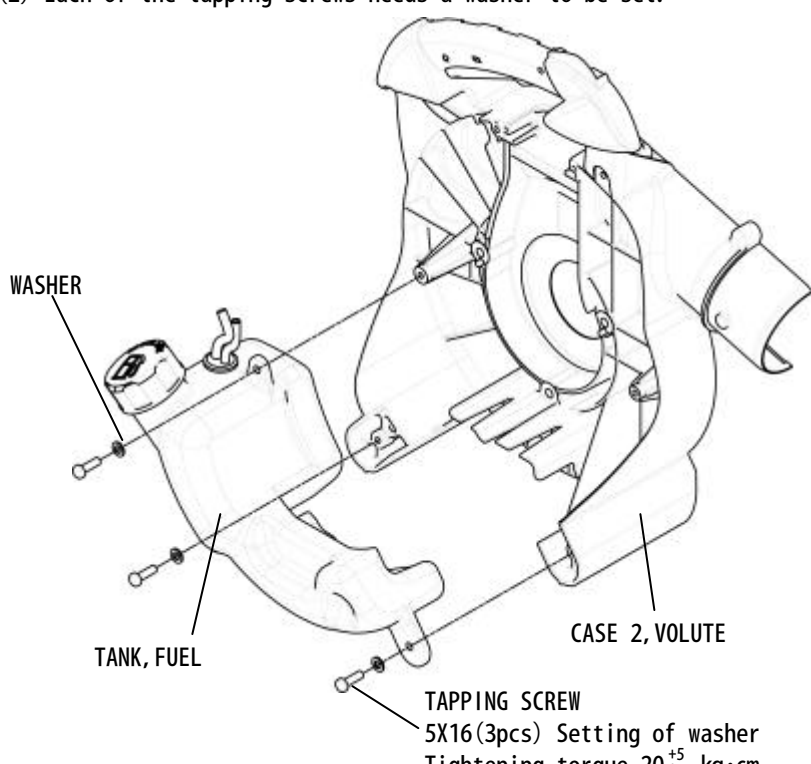
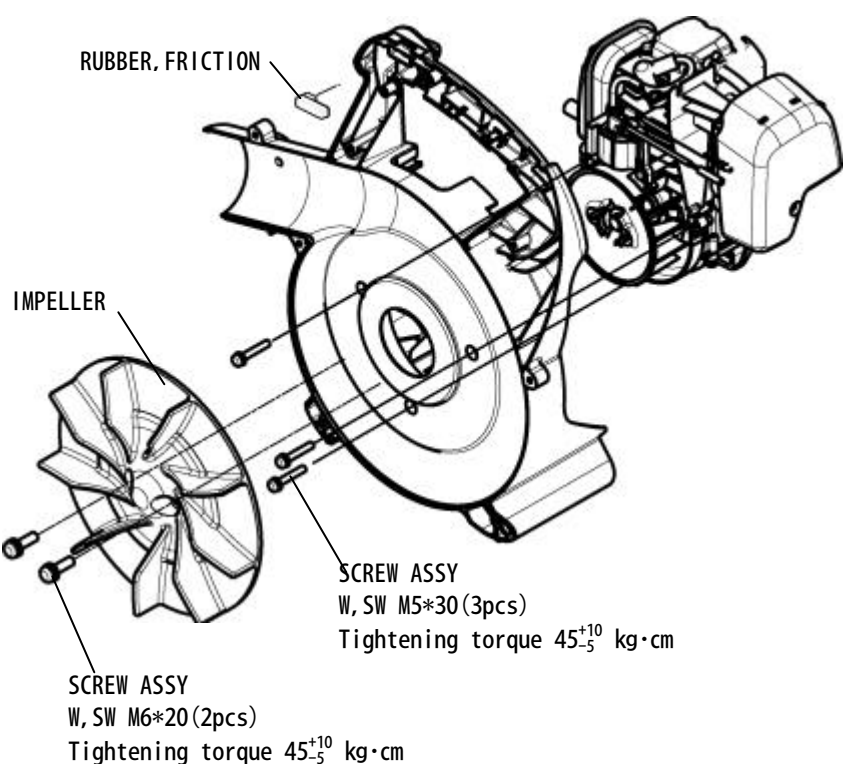
2. Tightening torque of each part.

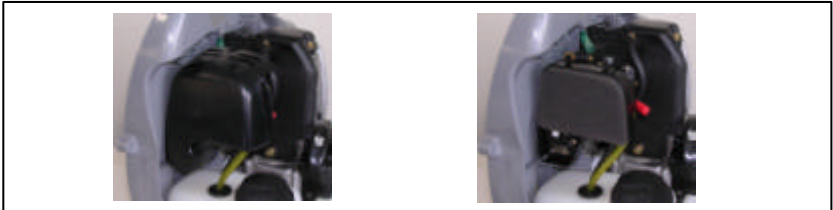
No.	Tightening part	Tightening torque (kg·cm)	The kind of screw	pcs
1	TANK, FUEL ~CASE 2, VOLUTE	20 $\begin{smallmatrix} +5 \\ 0 \end{smallmatrix}$	5×16 TAPPING SCREW (Setting of washer)	3pcs
2	ENGINE ~CASE 2, VOLUTE	45 $\begin{smallmatrix} +10 \\ -5 \end{smallmatrix}$	M5×30 W, SW SCREW	3pcs
3	IMPELLER ~FLYWHEEL	45 $\begin{smallmatrix} +10 \\ -5 \end{smallmatrix}$	M6×20 W, SW SCREW	2pcs
4	CASE 1, VOLUTE ~CASE 2, VOLUTE	15 $\begin{smallmatrix} +5 \\ 0 \end{smallmatrix}$	5×16 TAPPING SCREW	10pcs
5	COVER, ENGINE ~CASE 2, VOLUTE	15 $\begin{smallmatrix} +5 \\ 0 \end{smallmatrix}$	5×16 TAPPING SCREW	3pcs
6	COVER, ENGINE ~RECOIL STARTER ~ENGINE	15 $\begin{smallmatrix} +10 \\ -5 \end{smallmatrix}$	M4×16 W, SW SCREW	2pcs
7	COVER, AIR CLEANER ~PLATE, AIR CLEANER	5~10	M5×14 W, SW SCREW	1pc (By manual acceptable)

NO.	Part name	Assembling Instructions
1	TANK, FUEL ~CASE 2, VOLUTE	<p>(1) Fix the fuel tank to the CASE 2, VOLUTE at the ears at the bottom of the casing.</p> <p>(2) Each of the tapping screws needs a washer to be set.</p>  <p>WASHER</p> <p>TANK, FUEL</p> <p>CASE 2, VOLUTE</p> <p>TAPPING SCREW 5X16(3pcs) Setting of washer Tightening torque 20_{0}^{+5} kg·cm</p>
2	ENGINE ~CASE 2 VOLUTE ~IMPELLER ~RUBBER, FRICTION	<p>(1) Fix the engine to the CASE 2, VOLUTE with the knock positions united.</p> <p>(2) Be careful not to cause the wires to come away from the groove when mounting the engine.</p>  <p>RUBBER, FRICTION</p> <p>IMPELLER</p> <p>SCREW ASSY W, SW M5*30(3pcs) Tightening torque 45_{-5}^{+10} kg·cm</p> <p>SCREW ASSY W, SW M6*20(2pcs) Tightening torque 45_{-5}^{+10} kg·cm</p>

NO.	Part name	Assembling Instructions
3	STOP SWITCH ~CONTROL CABLE ~LEVER, THROTTLE	<p>(1) Put off an COVER, AIR CLEANER.</p>  <p>(2) Connect the lead wires of the STOP SWITCH with the corresponding lead wires of the COIL. Let the former lead wires through the hole of the CASE 2, VOLUTE and the STOP SWITCH terminals. Let the latter lead wires (the black one above and red one below) through the helical groove at the INSULATOR. Set the terminals downward.</p>  <p>(3) Insert the CONTROL CABLE (the end with the elbow attached) into the screw, letting the CONTROL CABLE through the hole of the CASE 2, VOLUTE.</p>  <p>(4) Fix the STOP SWITCH. Tuck the lead wires in between the guides and press the wires with the CONTROL CABLE. At last, fix the LEVER, THROTTLE.</p>  <p>(5) Fix the COVER, AIR CLEANER with screws.</p>
	SCREW ASSY W, SW M5X14 (1pc) Tightening torque 5~10 kg·cm (By manual acceptable)	

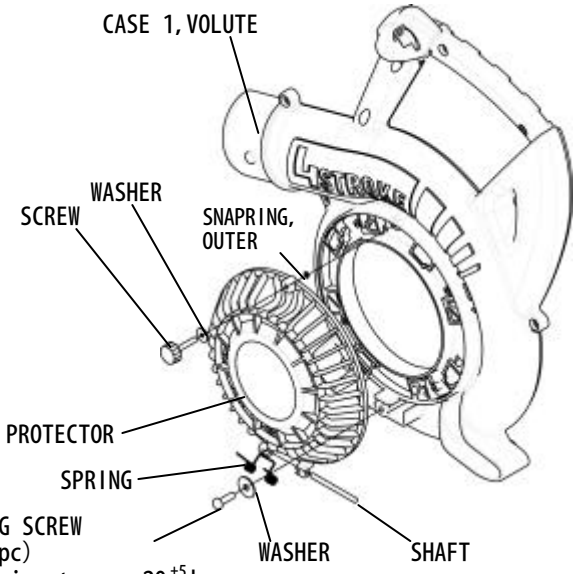
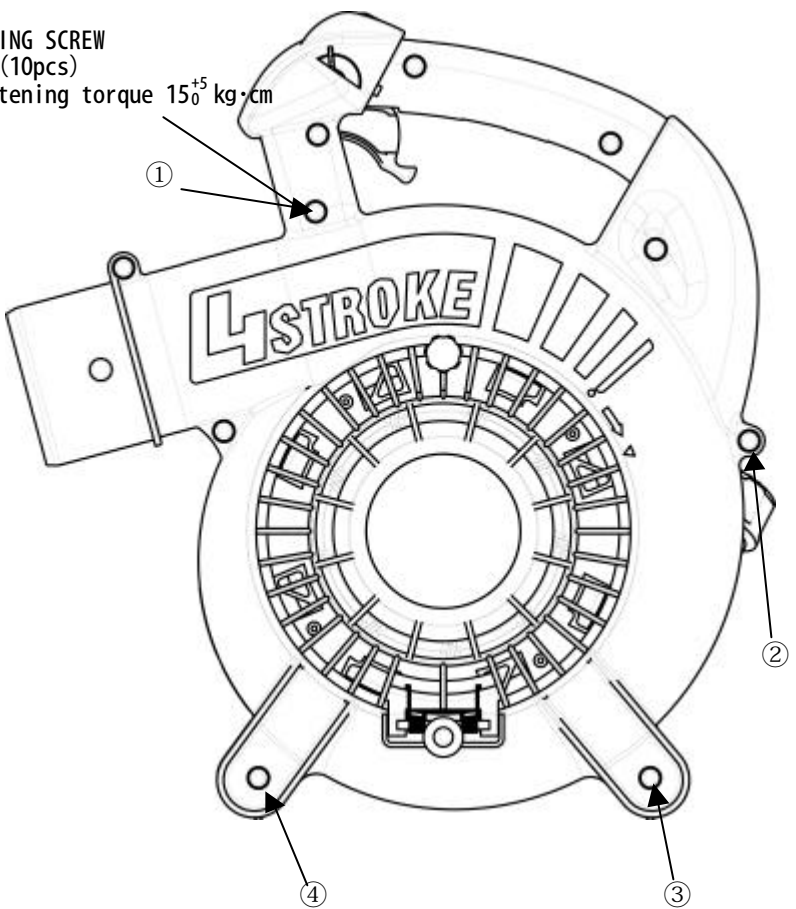
NO.	Part name	Assembling Instructions
4	PROTECTOR ~CASE 1, VOLUTE	 <p> CASE 1, VOLUTE SCREW WASHER SNAPPING, OUTER PROTECTOR SPRING TAPPING SCREW 5X16 (1pc) Tightening torque 20_0^{+5} kg·cm WASHER SHAFT </p>
5	CASE 1, VOLUTE ~CASE 2, VOLUTE	<p> (1) Fix the CASE 1, VOLUTE to the CASE 2, VOLUTE according to the order shown below. Be sure to place the ribs of the CASE 1, VOLUTE under the corresponding ribs of the CASE 2, VOLUTE. </p>  <p> TAPPING SCREW 5X16 (10pcs) Tightening torque 15_0^{+5} kg·cm </p>

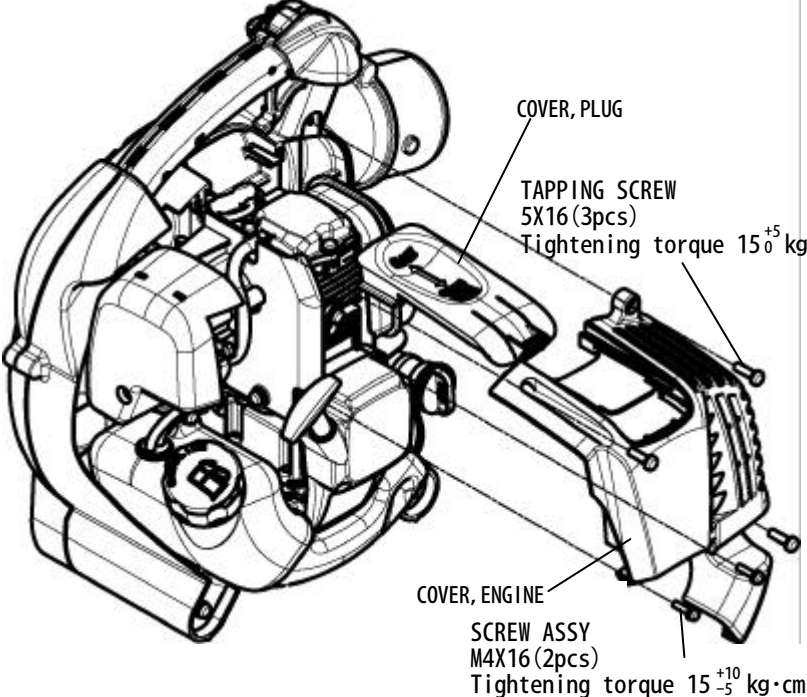
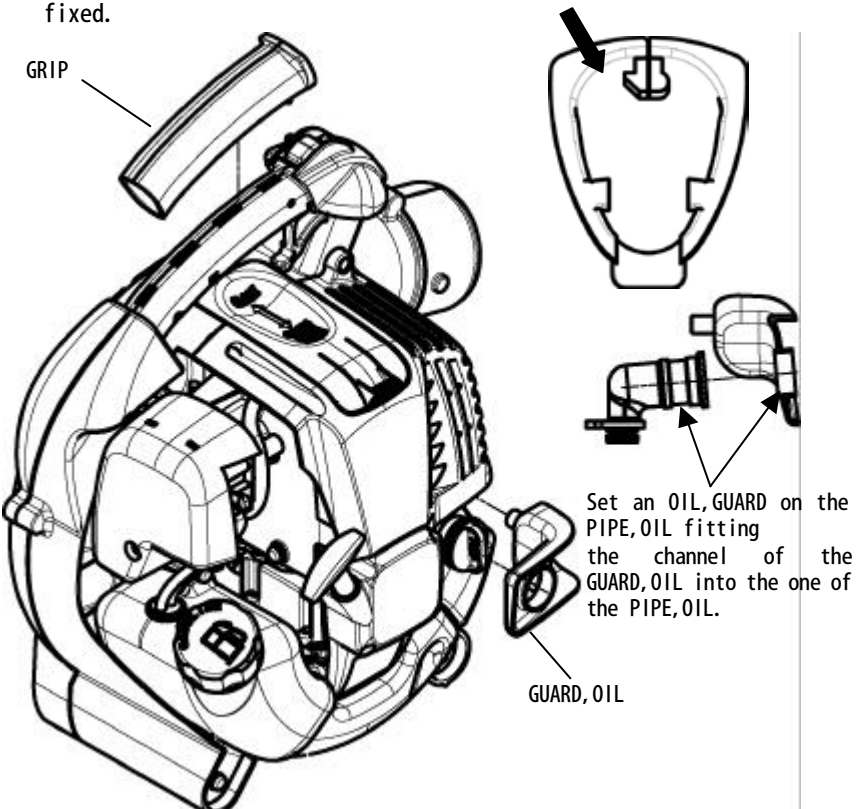
NO.	Part name	Assembling Instructions
6	CASE 2, VOLUTE ~COVER, PLUG ~COVER, ENGINE	<p>(1) Fix the PLUG, COVER in advance to the COVER, ENGINE.</p> <p>(2) Make sure that the lead wires and CONTROL CABLE are tucked in the helical groove when fixing the COVER, ENGINE.</p> 
7	GRIP ~GUARD, OIL	<p>(1) Fix the GRIP to the handle at the CASE 2 VOLUTE side (indicated by the arrow shown below).</p> <p>(2) Apply mild detergent to the GRIP or GUARD, OIL if they are difficulty fixed.</p> 

3. ENGINE DISASSEMBLY

Step	Part to remove	Procedure	Fastener	PCS	Notice	Special tool
1	INSULATOR	1) Remove the PLATE, AIR CLEANER.	M5X8mm	2	Fasten with the CARBURETOR.	
		2) Remove the breather-pipe and the return pipe from the cylinder side.			Use a small flat-head screwdriver for easy removal.	Small flat-head screwdriver
		3) Remove the INSULATOR.	M5X18mm M5X14mm	2 1		
2	AIR CLEANER BREATHER	1) Remove the PLATE, SEPARATOR.			Be sure to pull the PLATE, SEPARATOR by its body. Do not pull the PLATE, SEPARATOR by the square pipe to avoid its breakage.	
		2) Remove the GASKET, SEPARATOR.				
		3) Remove the PLATE, CHECK VALVE. (with the CHECK VALVE).			Use a small flat-head screwdriver at the hook of the PLATE, CHECK VALVE to remove it.	Small flat-head screwdriver
		4) CHECK VALVE (1)			Do not let the CHECK VALVE (1) missing.	
3	MUFFLER, EXHAUST	1) Remove the MUFFLER, EXHAUST.	M5X40mm	2		
4	STARTER REWIND	1) Remove the STARTER REWIND.	M4X16mm	2		
		2) Remove the PULLEY.			Hit with a hammer a metal bar supported by the hand in one of the holes of the PULLEY as shown in the figure (right-handed screw).	Metal bar, hammer
5	FLYWHEEL	1) Remove the COIL.	M4X20mm	2		
		2) Remove the FLYWHEEL.	M6X16mm	1	Using a flywheel puller, rotate the center shaft clockwise.	Flywheel puller
6	PLUG SPARK	1) Remove the PLUG SPARK.				16mm plug wrench
7	CASE, OIL	1) Remove the CASE, OIL.	M5X18mm	4	Tap the recoil side of the OIL CASE using a plastic or wooden hammer.	Plastic or wooden hammer
8	RETAINER PLATE	1) Remove the TUBE, OIL.			Hold TUBE, OIL root and pull out TUBE, OIL with the aid of a small flat-head screwdriver	Small flat-head screwdriver
		2) Remove the RETAINER PLATE.	M4X10mm	1	Do not let the LEAD VALVE missing.	
9	ROCKER COVER	1) Remove the ROCKER COVER.	M5X16mm	3		
10	COVER, CAMGEAR	1) Remove the COVER, CAMGEAR.	M5X14mm	3		
11	CAMGEAR	1) Remove the SHAFT, CAMLIFTER.			Position the cam peak portion down.	
		2) Remove the CAMLIFTER.				
		3) Remove the SHAFT, CAMGEAR.				
		4) Remove the CAMGEAR.				
		5) Remove the PUSH ROD.				
12	ROCKER ARM	1) Remove the ROCKER SHAFT.			Pull it out by holding with a pair of pincers the shaft seen between the intake and exhaust ROCKER ARMS.	
		2) Remove the ROCKER ARM.				
13	CRANK CASE	1) Remove the CRANK CASE.	M5X14mm	8	Tap the recoil side of the CRANKCASE using a plastic or wooden hammer.	Plastic or wooden hammer
14	CRANKSHAFT COMPL.	1) Remove the CRANKSHAFT COMPL.			Do not damage the OIL SEAL.	
15	VALVE	1) Remove the RETAINER, SPRING.			Support the VALVE from the inner side of the CYLINDER, push RETAINER, SPRING and slide it.	
		2) Remove the VALVE.				
		3) Remove the SPRING, VALVE.				
16	PISTON	1) Remove the CLIP.			Prevent dust from getting in the BEARING at the ROD, CONNECTING small end.	
		2) Remove the PIN, PISTON.				
		3) Remove the RING, PISTON.			Widening the open end of the ring might break it.	

4. ENGINE REASSEMBLY

Engine reassembly procedure

1. Notice

- Clean parts completely specifically the PISTON, CYLINDER, CRANKCASE, CRANKSHAFT and BEARINGS.
- Remove completely all the carbon deposit from the COMBUSTION CHAMBER and the PISTON top.
- Test the lip of the OIL SEALS for damage. Replace damaged OIL SEALS with new ones. Apply oil over the lip before reassembly.
- Replace all GASKETS with new ones.
- Replace PINS and SCREWS with new ones if necessary.
- Tighten up the tightening torque specified parts according to the specified tightening torque.
- Apply 4-stroke engine oil over the rotating portions and sliding surfaces.
- Check and adjust the clearances.
- After reassembling each of the rotatable main parts, rotate by hand to test it for bad movements and abnormal noises.

2. Tightening torque

No.	Tightening part	Tightening torque (kg·cm)	Screw	PCS
1	CRANKCASE ~RETAINER PLATE	30 $\begin{smallmatrix} +10 \\ 0 \end{smallmatrix}$	M4 × 10 SW SOCKET	1
2	CYLINDER BLOCK ~CRANKCASE	55 ±10	M5 × 14 SOCKET	8
3	CRANKCASE ~CASE, OIL	45 $\begin{smallmatrix} +10 \\ -5 \end{smallmatrix}$	M5 × 18 W, SW SCREW	4
4	COVER, CAMGEAR	45 $\begin{smallmatrix} +10 \\ -5 \end{smallmatrix}$	M5 × 14 W, SW SCREW	3
5	IGNITION COIL	20 $\begin{smallmatrix} +20 \\ 0 \end{smallmatrix}$	M4 × 20 W, SW SCREW	2
6	FLYWHEEL	105 ±15	M6 × 16 W, SW BOLT	1
7	ROCKER ARM ADJUST SCREW~NUT	50 $\begin{smallmatrix} +15 \\ 0 \end{smallmatrix}$	M5 NUT	2
8	ROCKER COVER	45 $\begin{smallmatrix} +10 \\ -5 \end{smallmatrix}$	M5 × 16 W, SW SCREW	3
9	MUFFLER EXHAUST	75 $\begin{smallmatrix} +15 \\ -5 \end{smallmatrix}$	M5 × 40 W SOCKET	2
10	PLUG, SPARK	110 ±20	M10 × P1.0	1
11	INSULATOR	45 $\begin{smallmatrix} +10 \\ -5 \end{smallmatrix}$	M5 × 18 W, SW SCREW M5 × 14 W, SW SCREW	2 1
12	PLATE, AIR CLEANER ~CARBURETOR ~INSULATOR	20 $\begin{smallmatrix} +20 \\ 0 \end{smallmatrix}$	M5 × 68 SUS SCREW	2
13	PIPE, OIL	45 $\begin{smallmatrix} +10 \\ -5 \end{smallmatrix}$	M5 × 12 W, SW SCREW	1
14	RECOIL STARTER	15 $\begin{smallmatrix} +10 \\ -5 \end{smallmatrix}$	M4 × 16 W, SW SCREW	2

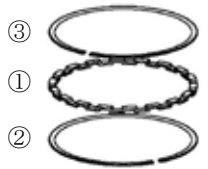
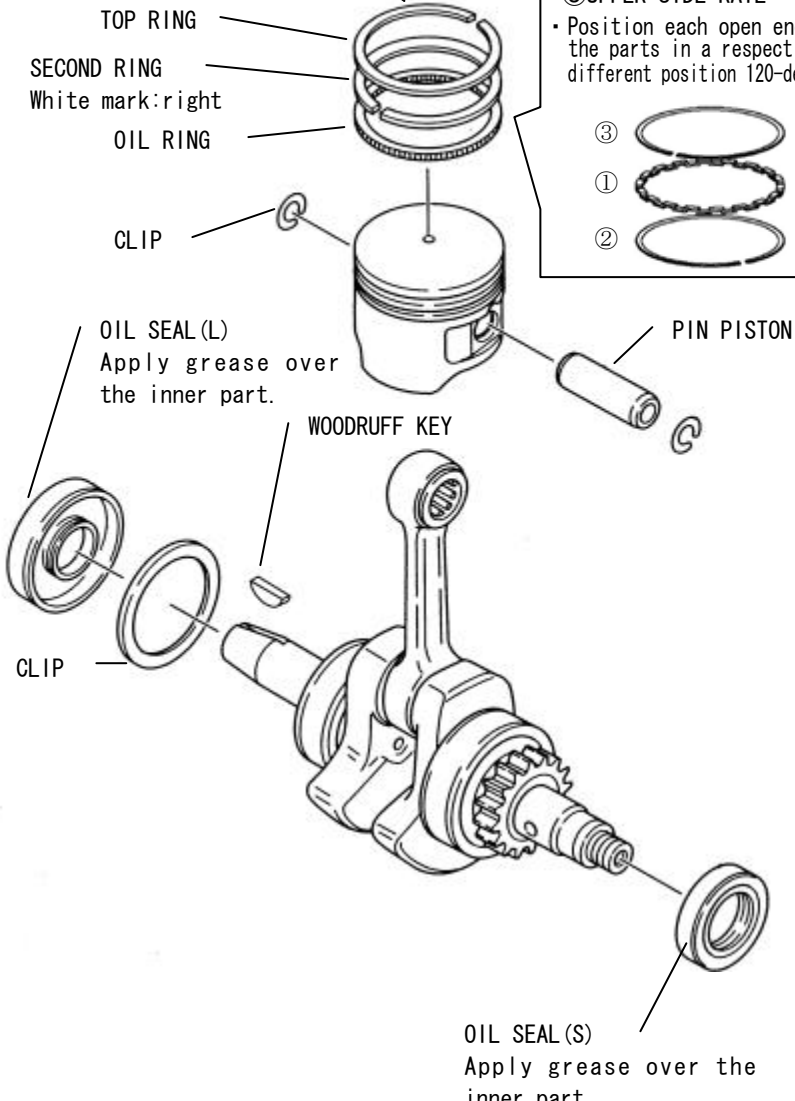
NO.	Part name	Procedure
1	NEEDLE ROLLER BEARING ROD LARGE AND SMALL ENDS	(1) Apply grease over the inside of the BEARINGS and press the PIN into it.
2	PISTON and CRANKSHAFT COMPL	<p>(1) Apply 4-stroke engine oil over the PISTON RINGS and OIL RING after placing them.</p> <div data-bbox="638 459 1125 548" style="border: 1px solid black; padding: 5px; margin: 10px 0;"> <p>• Position the open end of TOP RING and SECOND RING in the opposite direction.</p> </div> <div data-bbox="1189 515 1508 929" style="border: 1px solid black; padding: 5px; margin: 10px 0;"> <p>• OIL RING assembly order ① SPACER ② LOWER SIDE RAIL ③ UPPER SIDE RAIL</p> <p>• Position each open end of the parts in a respectively different position 120-degree.</p>  </div> 

NO.	Part name	Procedure
3	CYLINDER BLOCK VALVE SPRING ~RETAINER, SPRING	<p data-bbox="635 210 1501 271">(1) Apply 4-stroke engine oil over the inner wall of the CYLINDER, the sliding surface of the PISTON and the valve holes before reassembly.</p> <div data-bbox="635 286 1460 1377"> </div> <p data-bbox="635 1406 1517 1541">(2) Apply the oil over the valve guide hole before inserting VALVE. To insert VALVE, reassemble SPRING and RETAINER as shown below, insert VALVE into the RETAINER hole and slide RETAINER while pushing SPRING.</p> <div data-bbox="694 1547 1476 1982"> <p data-bbox="853 1659 981 1704">Slide the SPRING down.</p> <p data-bbox="1300 1648 1476 1693">Slide the RETAINER, SPRING.</p> </div>

NO.	Part name	Procedure
4	CYLINDER BLOCK ~CRANKCASE	<p data-bbox="635 210 1364 271">(1) Join CYLINDER BLOCK and CRANKCASE on each housing blower installation surface.</p> <div data-bbox="651 309 1460 1301" style="text-align: center;"> <p data-bbox="651 488 869 517">CYLINDER BLOCK SET</p> <p data-bbox="1273 1016 1460 1046">CRANKCASE COMPL</p> <p data-bbox="651 1182 869 1301">SOCKET HEAD BOLT M5*14 (8 pcs) Tightening torque 55±10 kg·cm</p> </div> <div data-bbox="539 1346 1086 1877" style="border: 1px solid black; padding: 5px; margin-top: 10px;"> <p data-bbox="555 1352 927 1382"><Tightening order (important)></p> </div> <div data-bbox="1098 1346 1497 1877" style="border: 1px solid black; padding: 5px; margin-top: 10px;"> <p data-bbox="1118 1352 1449 1382"><CRANKCASE upper side></p> <p data-bbox="1118 1675 1497 1794">·Check that liquid packing (TB1216) is applied evenly over CRANKCASE (hatched surface) before reassembly.</p> </div>

NO.	Part name	Procedure
5	CRANKCASE ~CASE, OIL	<p>CASE, OIL</p> <p>SCREW W, SW M5*18 (4 pcs) Tightening torque 45^{+10}_{-5} kg·cm</p> <p>WEIGHT, OIL</p> <p>TUBE, OIL</p> <p>SOCKET HEAD BOLT SW M4*10 (1 pcs) Tightening torque 30~40 kg·cm</p> <p>RETAINER PLATE</p> <p>GASKET, CASE</p> <p>LEAD VALVE</p> <p>OIL FILLER HOLE</p> <p>Attach LEAD VALVE with the cut-out facing to OIL FILLER HOLE.</p> <p>Cut-out</p>

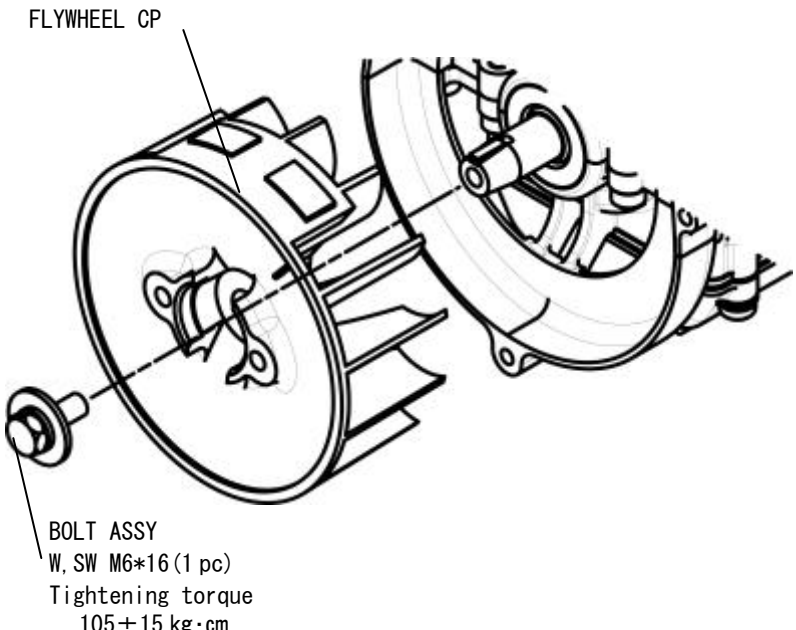
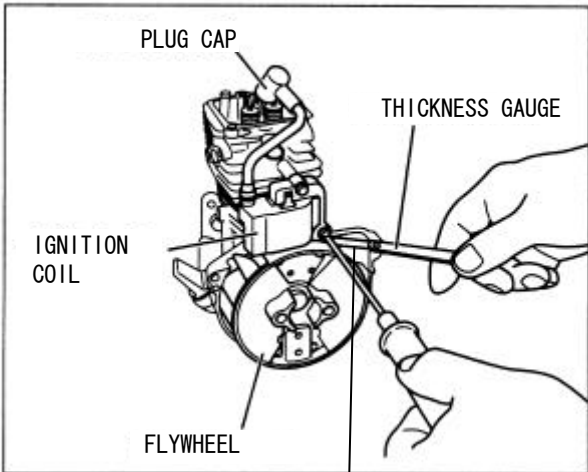
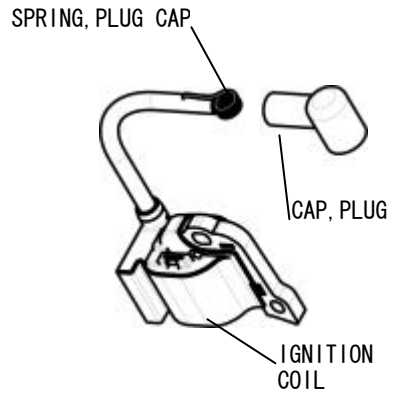
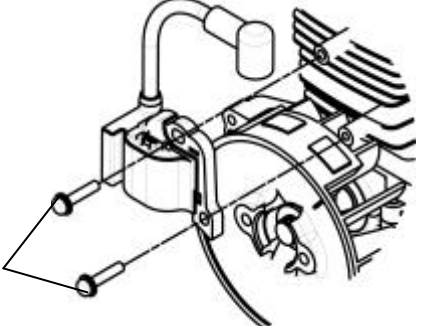
NO.	Part name	Procedure
6	FLYWHEEL	<p>(1) Degrease CRANKSHAFT and FLYWHEEL tapered portion completely before joining them.</p> <p>(2) Align FLYWHEEL key groove with CRANKSHAFT key.</p> <div style="text-align: center;">  </div>
7	IGNITION COIL GROMMET ~CAP, PLUG	<p>(1) Attach SPRING, PLUG CAP to the HIGHT-TENSION CODE.</p> <p>(2) Insert the HIGHT-TENSION CODE with the SPRING, PLUG CAP into PLUG CAP.</p> <p>(3) Position the holes of SPRING, PLUG CAP and PLUG CAP in the same direction.</p> <div style="display: flex; justify-content: space-around;"> <div style="text-align: center;">  <p>·Air gap : 0.3mm</p> </div> <div style="text-align: center;">  </div> </div> <div style="text-align: center; margin-top: 20px;">  </div>

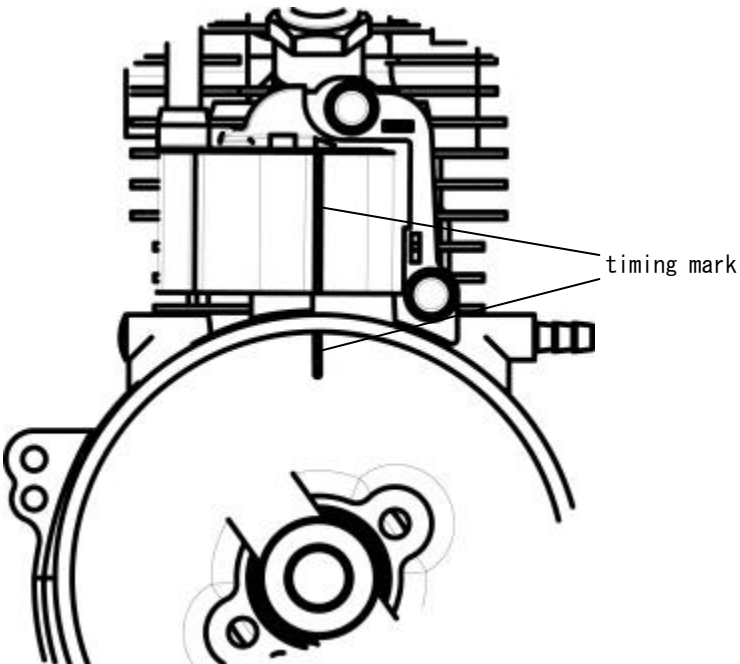
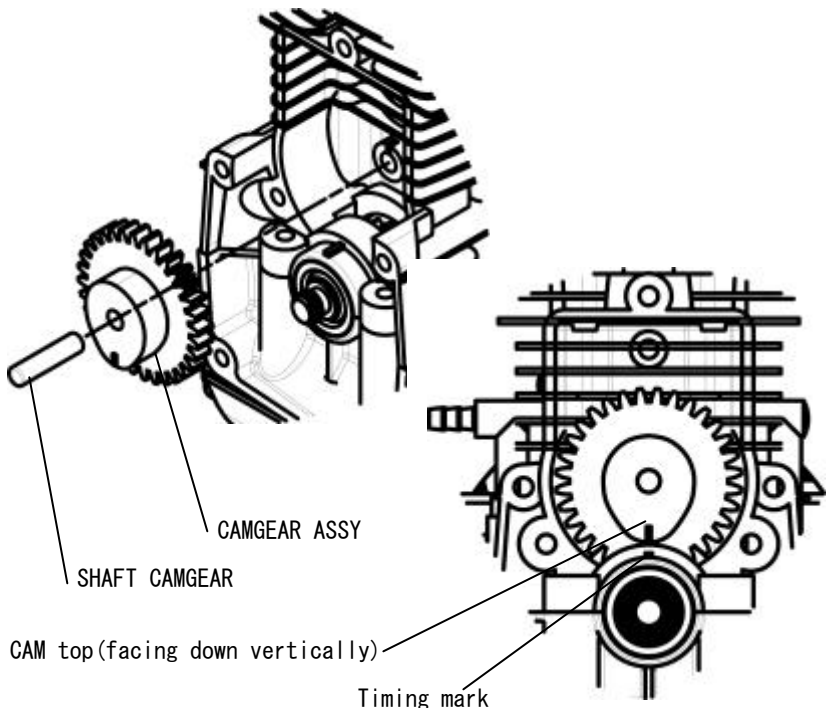
NO.	Part name	Procedure
8	CAMGEAR	<p>(1) Align the mark punched on FLYWHEEL(key position groove) with the timing mark on IGNITION COIL(Do not let FLYWHEEL move).</p>  <p>(2) Join CAMGEAR to CRANKGEAR with CAM top facing down vertically (use the timing mark for reference).</p> 

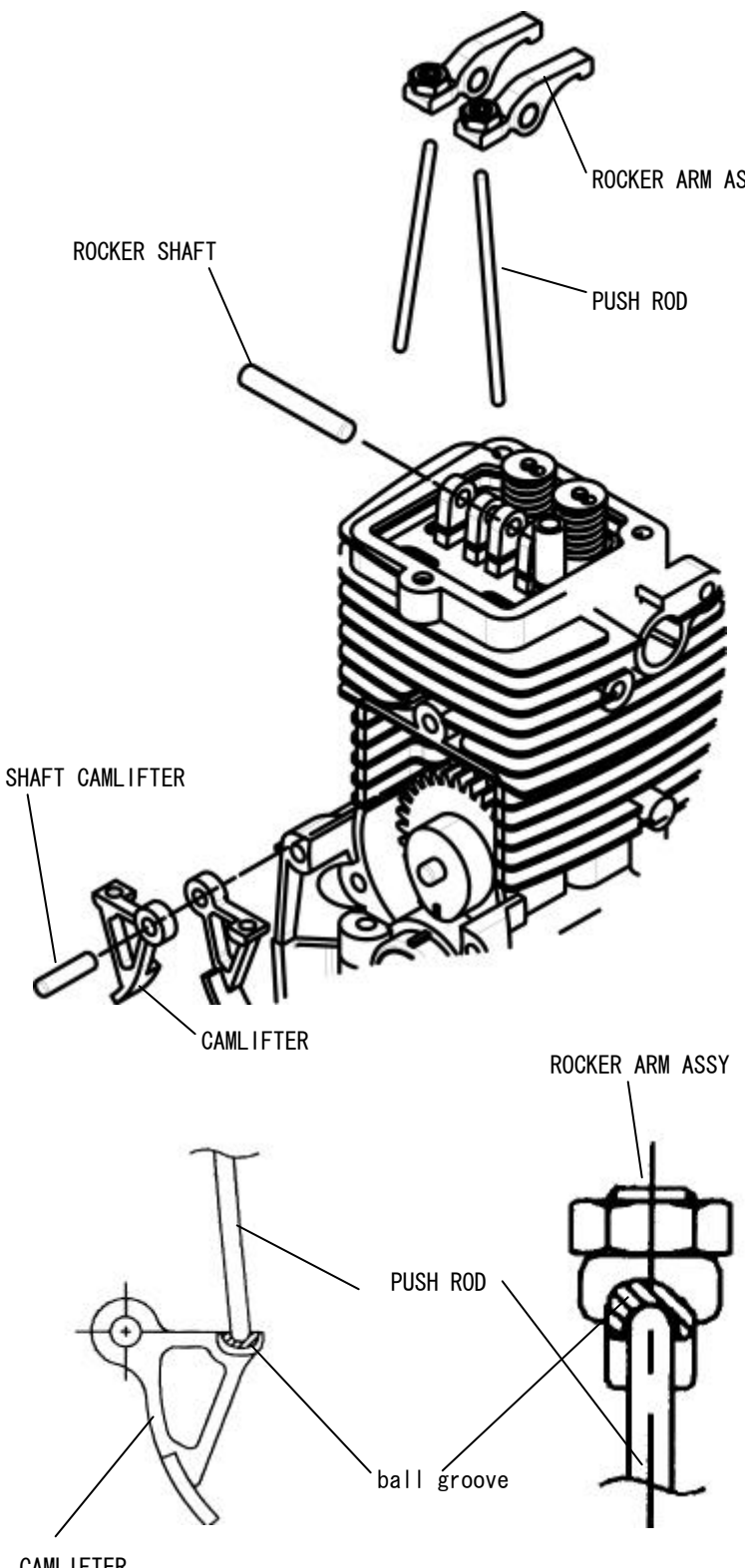
NO.	Part name	Procedure
9	PUSH ROD CAM LIFTER ~ROCKER ARM	<p>(1) Join the CAMLIFTER to CAMGEAR.</p> <p>(2) Insert PUSH ROD into the PUSH ROD passage of CYLINDER. Align the PUSH ROD end with the CAM LIFTER ball groove.</p> <p>(3) Apply the oil over the ROCKER SHAFT hole before inserting ROCKER SHAFT.</p> 

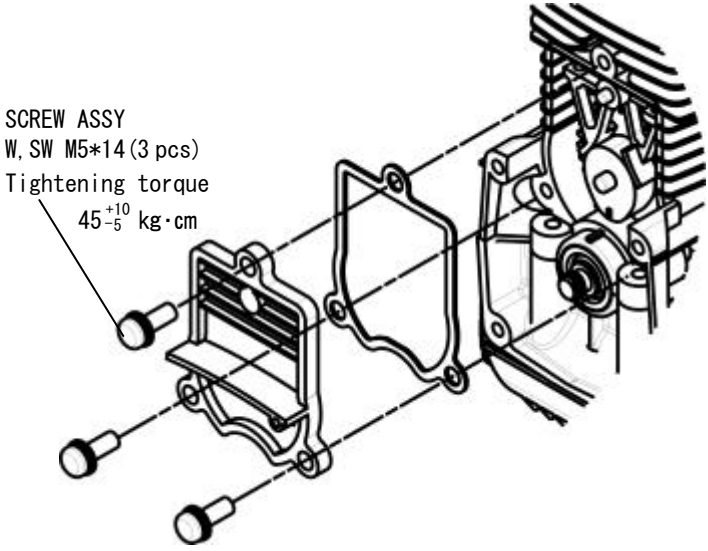
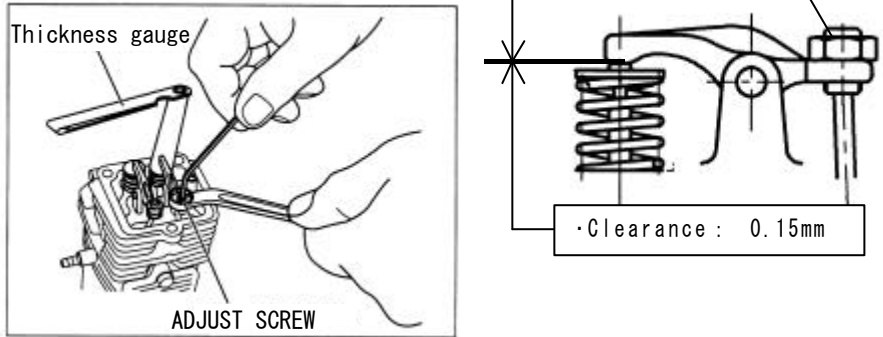
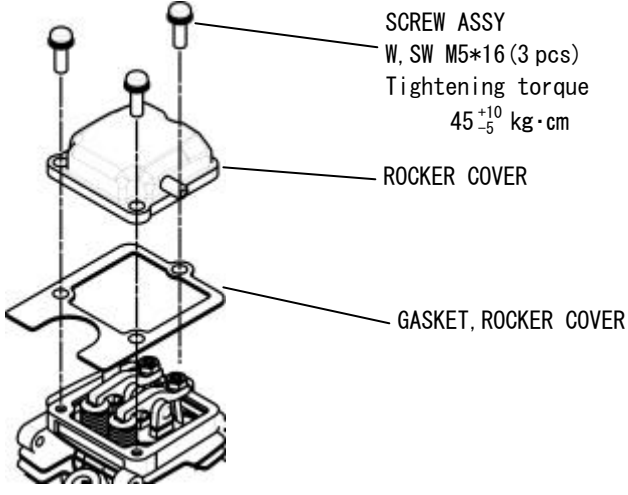
NO.	Part name	Procedure
10	COVER, CAMGEAR	<p>(1) Apply the oil over the sliding surface of CAMGEAR and CAM LIFTER before fitting COVER, CAMGEAR.</p>  <p>SCREW ASSY W, SW M5*14 (3 pcs) Tightening torque 45^{+10}_{-5} kg·cm</p>
11	VALVE CLEARANCE	<p>(1) Loosen NUT and adjust VALVE CLEARANCE by rotating ADJUST SCREW with a hexagon bar wrench. Adjust VALVE CLEARANCE at the compression top dead center (the position of the CAM top and FLYWHEEL should remain in the same one at no.9).</p> <p>(2) Tighten NUT firmly after the adjustment.</p>  <p>Thickness gauge</p> <p>ADJUST SCREW</p> <p>NUT 50^{+15}_{0} kg·cm Tightening torque</p> <p>· Clearance : 0.15mm</p>
12	ROCKER COVER	<p>(1) Apply the oil over the sliding surface in the vicinity of ROCKER ARM before fitting ROCKER COVER.</p>  <p>SCREW ASSY W, SW M5*16 (3 pcs) Tightening torque 45^{+10}_{-5} kg·cm</p> <p>ROCKER COVER</p> <p>GASKET, ROCKER COVER</p>

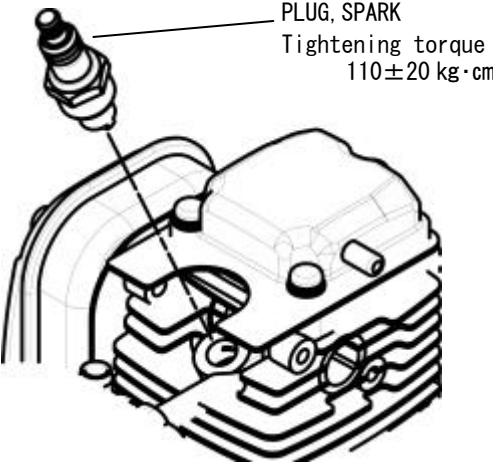
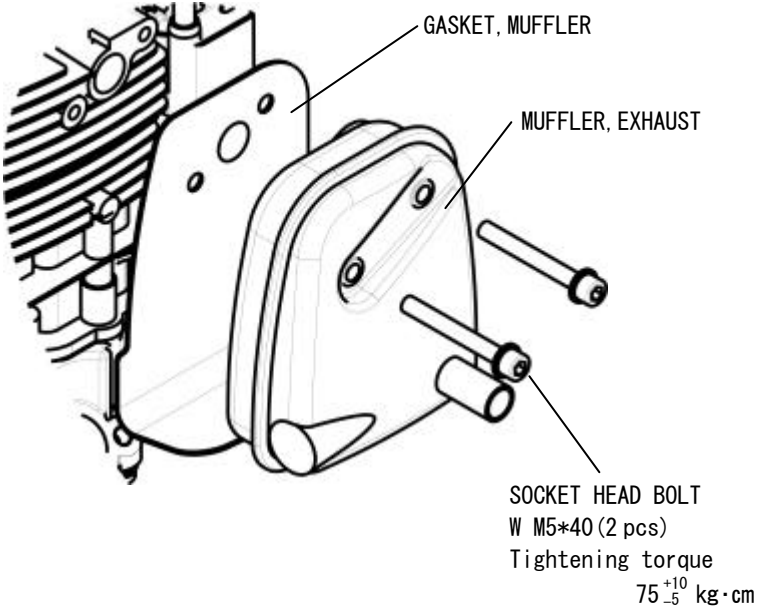
NO.	Part name	Procedure
13	PLUG, SPARK	 <p>PLUG, SPARK Tightening torque 110 ± 20 kg·cm</p>
14	MUFFLER EXHAUST	 <p>GASKET, MUFFLER MUFFLER, EXHAUST SOCKET HEAD BOLT W M5*40 (2 pcs) Tightening torque $75 \begin{smallmatrix} +10 \\ -5 \end{smallmatrix}$ kg·cm</p>

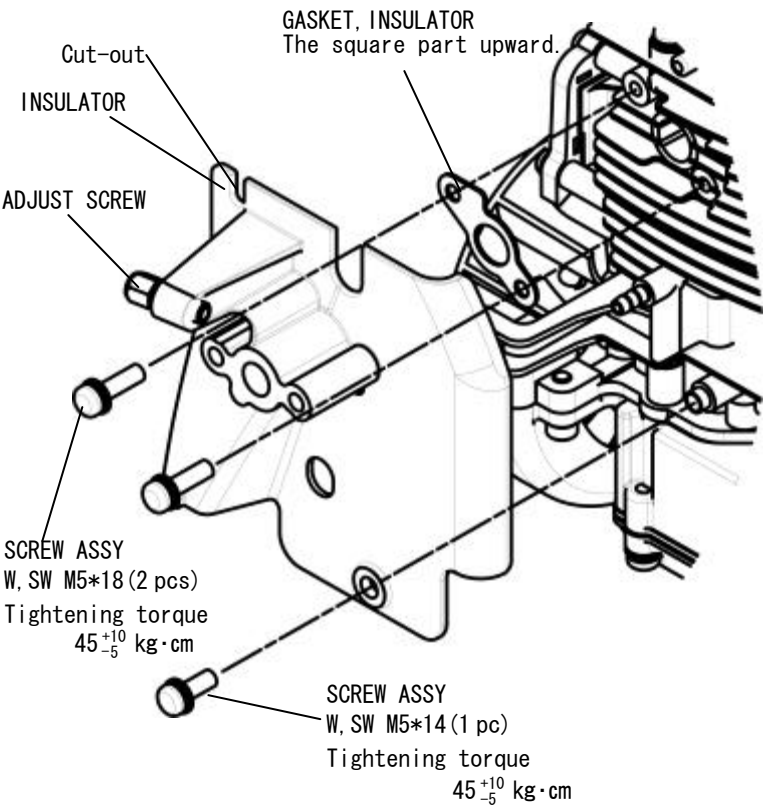
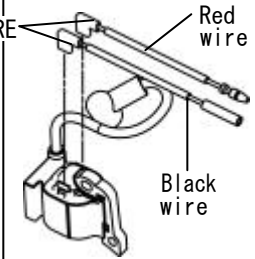
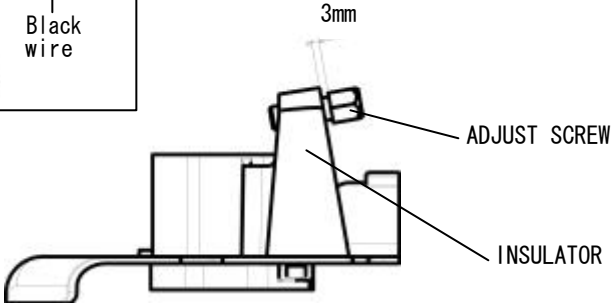
NO.	Part name	Procedure
15	INSULATOR	<p>(1) Run the lead wires, the red one down and black one up, through the upper cut-out of INSULATOR.</p> <p>(2) Join the red lead wire (male terminal) to the engine side (in the back).</p>  <p>SCREW ASSY W, SW M5*18 (2 pcs) Tightening torque 45^{+10}_{-5} kg·cm</p> <p>SCREW ASSY W, SW M5*14 (1 pc) Tightening torque 45^{+10}_{-5} kg·cm</p> <div data-bbox="683 1227 957 1568" style="border: 1px solid black; padding: 5px; margin: 10px 0;"> <p style="text-align: center;">WIRE fixing</p>  </div>  <p style="text-align: right;">3mm</p> <p style="text-align: right;">ADJUST SCREW</p> <p style="text-align: right;">INSULATOR</p>

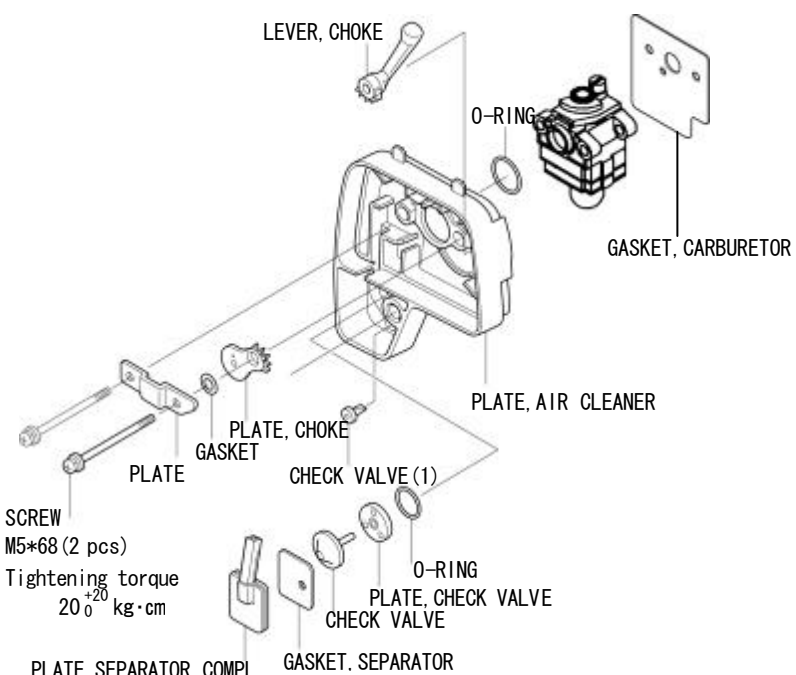
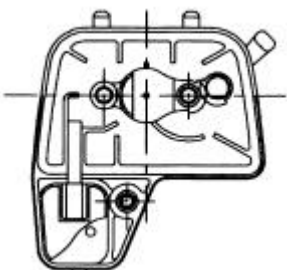
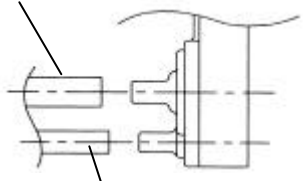
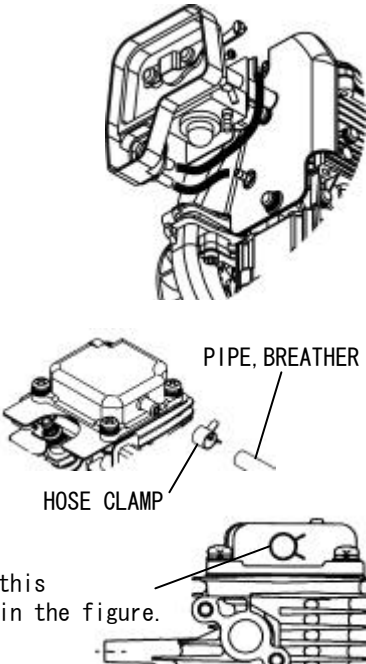
NO.	Part name	Procedure
16	CARBURETOR ~AIR CLEANER	<p>(1) Assemble PLATE, CHOKE PLATE, AIR CLEANER , PLATE , CARBURETOR GASKET, CARBURETOR , SPACER , GASKET , PIPE, BREATHER and RETURN PIPE.</p>  <p>LEVER, CHOKE O-RING GASKET, CARBURETOR PLATE, AIR CLEANER PLATE, CHOKE GASKET CHECK VALVE (1) SCREW M5*68 (2 pcs) Tightening torque 20⁺²⁰₀ kg·cm O-RING PLATE, CHECK VALVE CHECK VALVE PLATE, SEPARATOR COMPL GASKET, SEPARATOR</p> <div data-bbox="662 1003 1452 1339">  <p>LEVER, CHOKE Keep LEVER, CHOKE fully closed when fitting PLATE, CHOKE.</p> </div> <div data-bbox="646 1361 1029 1870">  <p>PIPE, BREATHER PIPE two-layer rubber</p> <p>When joining PIPE, BREATHER: 1. do not apply the oil; and 2. use diluted mild detergent with a ratio of 10(water) to 1(detergent).</p> </div> <div data-bbox="1061 1377 1444 2049">  <p>PIPE, BREATHER HOSE CLAMP</p> <p>Join HOSE CLAMP in this direction as shown in the figure.</p> </div>

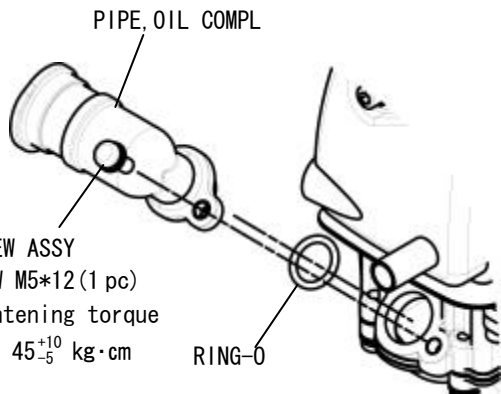
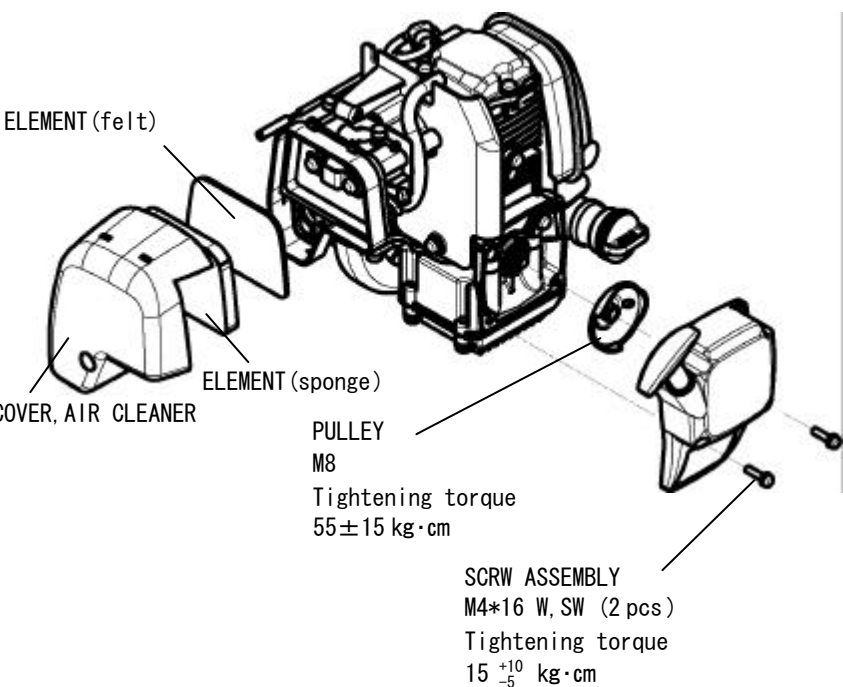
NO.	Part name	Procedure
17	PIPE, OIL	<p>(1) Do not let O-RING remaining between the flange face of PIPE, OIL COMPL and CRANKCASE.</p>  <p>PIPE, OIL COMPL</p> <p>SCREW ASSY W, SW M5*12 (1 pc) Tightening torque 45^{+10}_{-5} kg·cm</p> <p>RING-O</p>
18	RECOIL STARTER ~COVER, AIR CLEANER	 <p>ELEMENT (felt)</p> <p>COVER, AIR CLEANER</p> <p>ELEMENT (sponge)</p> <p>PULLEY M8 Tightening torque 55 ± 15 kg·cm</p> <p>SCRW ASSEMBLY M4*16 W, SW (2 pcs) Tightening torque 15^{+10}_{-5} kg·cm</p>

5. CARBURETOR DISASSEMBLY AND REASSEMBLY

This engine is equipped with a diaphragm type CARBURETOR.

1) Function and structure of the diaphragm system.

Since the fuel level is kept constant, in spite of any tilt angle of the engine, it can be operated at any position. The float chamber is provided with a diaphragm and covered by a cover. Negative pressure in the air intake passage causes the diaphragm to swell upward and thereby pushing up the hinge to open the valve. Upon the disappearance of the negative pressure, the valve is closed by the spring pressure. Then the fuel flow rate can be controlled by marking an appropriate determination of the diaphragm area and spring pressure.

2) Disassembly and reassembly

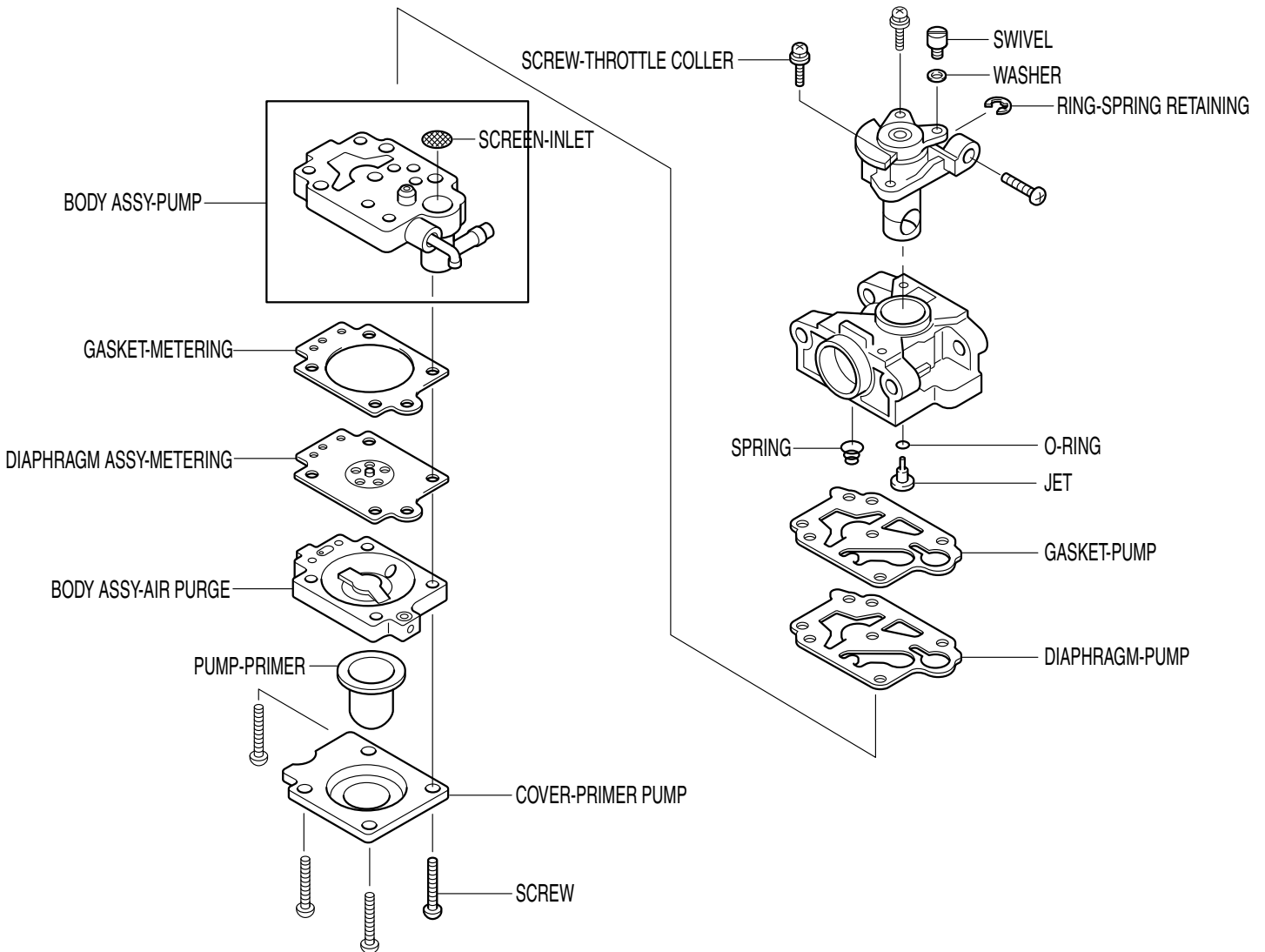

3) Notice

- ① Clean the CARBURETOR using clean gasoline before disassembly.
- ② Disassemble or reassemble referring to the deal drawing.
- ③ Do not disassemble the THROTTLE VALVE ASSY and PUMP BODY ASSY.

4) Disassembly and reassembly procedure

- ① Remove the screw (PUMP COVER) and then the PRIMER PUMP COVER. Remove dust clearly from the PRIMER PUMP if any.
- ② Remove the PUMP BODY ASSY from the body (do not let the SPRING missing). Remove dust clearly from the INLET SCREEN if any.
- ③ Remove the JET from the body.
- ④ Remove the SCREW (THROTTLE COLLAR) and then THROTTLE VALVE ASSY from the body.
- ⑤ Reassemble the JET and SPRING firmly when reassembling the CARBURETOR.

5) Checking procedure

- ① Clean the body using gasoline and blow it clearly with compressed air.
- ② Test the JET for dust and corrosion. The dust needs cleaning and blowing with compressed air and corrosion replacing with new one. (Note: The new JET should have the same number with that of the old one.)
- ③ Test the GASKETS for deformation and breakage. Replace bad gaskets with new ones if any.
- ④ The PUMP (DIAPHRAGM) should not be hardened or damaged.
- ⑤ The INLET VALVE and the OUTLET VALVE should be flat and not bent.
- ⑥ The DIAPHRAGM ASSY should be free of any hardening, damage or bend.
- ⑦ After cleaning the PUMP BODY ASSY, test it for deformation of the METERING LEVER and METERING LEVER SPRING, height of the METERING LEVER, dust stuck to the INLET SCREEN, and VALVE leakage, etc. To check the MAIN CHECK VALVE for its correct operation, place a vinyl or rubber hose at its end on the CHECK VALVE portion from the JET side and breath it at the other end. If you cannot breath it and valve closes when you breath it in, it works correctly. If not, immerse it in gasoline for about 10 minutes and then repeat the procedure described above. If the VALVE cannot be fixed even by doing this, replace it with a new PUMP BODY ASSY. (Note: Do not blow the MAIN CHECK VALVE with compressed air. If you use an air gun, keep it about 30cm away from the valve when the compressed air has a pressure of 6kg/cm²).
- ⑧ Test the PRIMER PUMP for any hole, breakage and abnormal hardening. Make sure that the COMBINATION VALVE works correctly.

6) Marks on CARBURETOR

Marks are stamped on the CARBURETOR as shown in the right figure:

- ① Model No.
- ② Date of manufacture

Example) ① : 116 ⇒ WYL116
② : 914 (March 29 to April 2, 1999)
└─ Week 14 (what week number in the year)
└─ last digit of the year

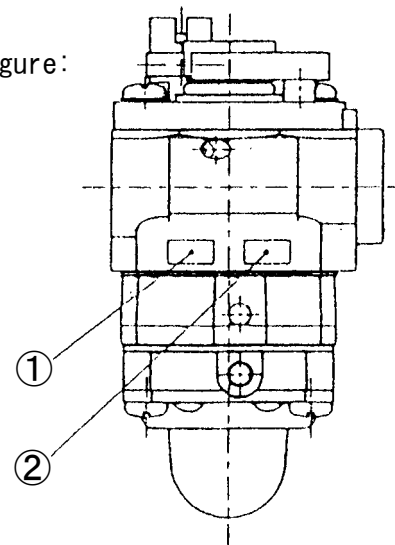

6. RECOIL STARTER

The RECOIL STARTER rarely malfunctions under normal use. When it fails, however, or needs greasing, disassemble and reassemble it according to the following procedure.

Tools : Screwdriver and pincens(pliers)

1) Disassembly

- (1) Remove the RECOIL STARTER from the engine.
- (2) Pull out the STARTER KNOB, press the ROTARY REEL with your thumb as shown in Fig.6-1 when the REEL cut-out comes to the STARTER ROPE OUTLET, and pull the STARTER ROPE to the inside of the RECOIL STARTER with a screwdriver. Using the cut-out, rewind the REEL to the direction of the arrow until it stops by controlling the rotation of the REEL with your thumb.

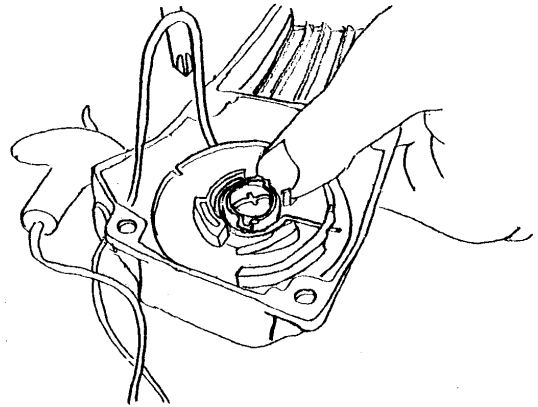

Fig.6-1

- (3) Remove the parts as shown in Fig.6-2.

Remove the REEL slowly by turning it back and forth gently in a way that SPIRAL SPRING will not come away from the REEL.

(See the other notice at page 30 for SPIRAL SPRING'S coming away.)

Untie the STARTER ROPE knot at the REEL end and take it away to complete the disassembly.

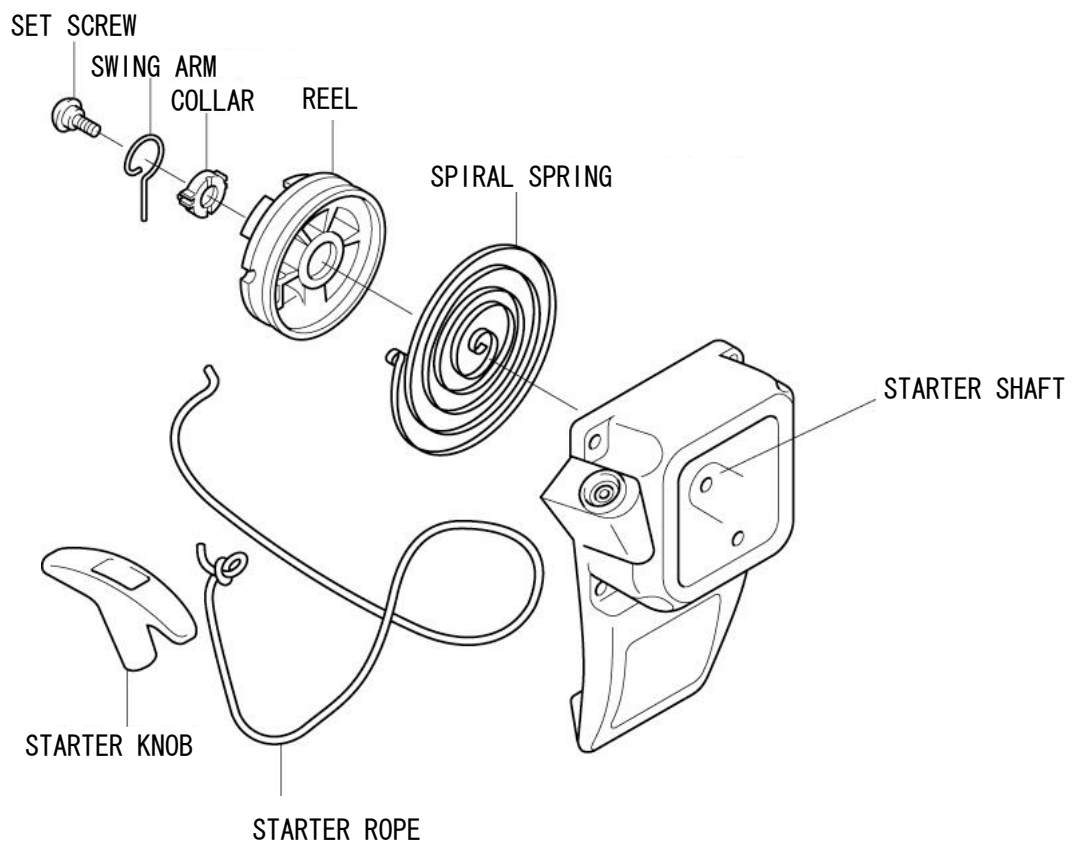

Fig.6-2

2) Reassembly

(1) Run the STARTER ROPE through the STARTER KNOB and make an overhand knot as shown in Fig. 6-3. Run the STARTER KNOB at its opposite side from the STARTER CASE to the REEL, make a knot in the same way, and put the ROPE end completely in the ROPE HOUSING of the REEL. Then, apply a small amount of grease over the STARTER SHAFT and SPIRAL SPRING.

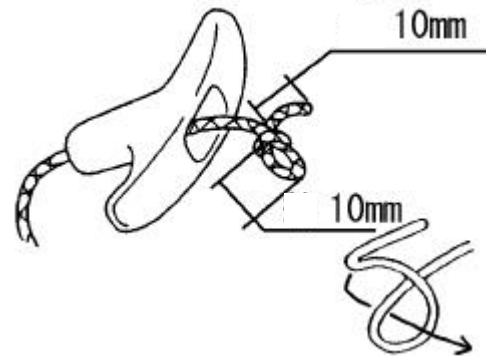

Fig. 6-3

(2) Make sure that the SPIRAL SPRING is fit completely in the spring groove of the REEL. Form the SPRING end to have 1 to 2 mm clearance between the SPIRAL SPRING inner end and REEL BUSH so that the STARTER SHAFT can hook on the HOOK securely as shown in Fig. 6-4. The SPIRAL SPRING inner portion (about 10cm-long from the end) can be charged in shape.

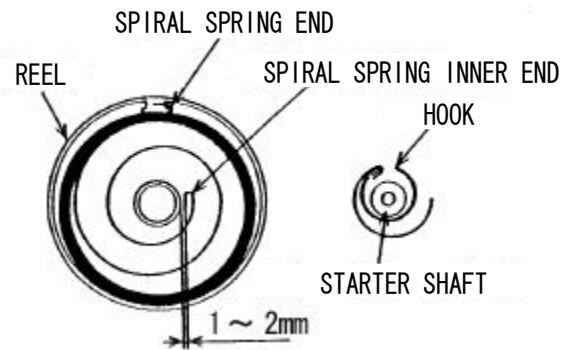

Fig. 6-4

(3) Before inserting the REEL in the STARTER CASE, wind the STARTER ROPE around the REEL three turns in the direction of the arrow shown in Fig. 6-5, draw out the third turn of the STARTER ROPE from the REEL cut-out, and fit the REEL completely inside the STARTER CASE so that the SPIRAL SPRING inner end can hook on the hook. then, hold the STARTER ROPE as shown in Fig. 6-5, and twist the REEL 4 to 5 turns in the direction of the arrow using the REEL cut-out. After the completion of winding, of the STARTER ROPE hold the REEL tightly to prevent the STARTER ROPE from winding back, pull the STARTER KNOB in order for the SPIRAL ROPE to tighten and then release the STARTER KNOB slowly. Reassemble the parts in reverse order of disassembly shown in Fig. 6-2. Tighten the SETSCREW firmly.



Fig. 6-5

※) Be sure to perform the following procedure in order to make sure that the parts have been fit completely.

3) Check after reassembly

(1) Pull the STARTER KNOB a few times:

- ① If the STARTER KNOB is too heavy to pull, check the associated parts whether they have been reassembled as instructed.
- ② If the RATCHET fails to function, check whether the parts such as the spring have been missing.

(2) Pull the STARTER KNOB to pull out the STARTER ROPE to the end:

- ① Unwind the STARTER ROPE 1 to 2 turns in the way as shown in Fig.6-1, since the SPIRAL SPRING may be over-stressed if the STARTER ROPE still remains in the rope groove.
- ② If the STARTER ROPE is found weak to move back, or the STARTER KNOB droops when you let it go, apply grease over the rotating and friction parts. If it does not recover, pull the STARTER KNOB such that the STARTER ROPE is pulled by 1 to 2 turns. (In this instance, make sure in the way described above that the SPIRAL SPRING is not over-stressed.)
- ③ If the SPIRAL SPRING comes away with a sound and the STARTER ROPE will not be moved back, reassemble the RECOIL STARTER from the beginning.

4) Other notice

(1) When the SPIRAL SPRING flies out:

Make a ring having a smaller diameter than that of the SPIRAL SPRING housing by a thin wire. Hook the SPIRAL SPRING at its outer end on the ring to wind it as shown in Fig.6-6, and fit it into the SPIRAL SPRING groove. Press the SPIRAL SPRING with your finger to prevent it from coming away and remove the ring slowly. The ring can easily be removed by prying it with the tip of a screwdriver. See Fig.6-4 for how to fit the SPIRAL SPRING correctly into the groove.

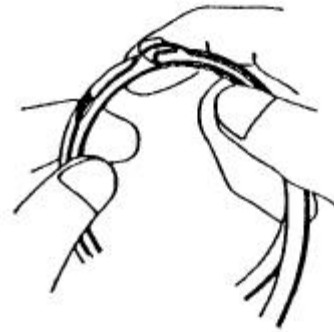

Fig. 6-6

(2) At off-season and disassembly:

Apply grease (heat-resistant type is preferable) over the rotating and friction parts at the end of the season and at disassembly.

(3) When the SWING ARM does not move smoothly:

Apply grease over the SWING ARM end and in the vicinity of place along which the end slides.

IV. MALFUNCTION AND REPAIR

Trouble	Work order	Point to be checked	Action to be done		
			Without problem	With problem	
CRANKSHAFT does not rotate.	1-1	Does the CRANKSHAFT rotate by pulling the RECOIL STARTER ?	Yes 2-1	No 1-2	
	1-2	Any breakage in the RECOIL STARTER ?	No 1-3	Repair the RECOIL STARTER. See P.P. 28~30.	
	1-3	Does the FLYWHEEL touch somewhere?	No 1-4	Is the clearance between the FLYWHEEL and COIL within the criterion (tolerance: 0.3 ± 0.1)? Remove foreign material such as gravel if any. See P. 18.	
	1-4	Does the CRANKSHAFT rotate by rotating the FLYWHEEL by hand?	Yes 1-1	Disassemble the engine to investigate. 1-5	
	1-5	Remove the rocker cover and COVER, CAMGEAR to test the CAMGEAR, etc. for defects.	No defect 1-6	Repair the VALVE, ROCKER ARM, PUSH ROD, CAMLIFTER and CAMGEAR if any defects were found. See P.P. 19~21.	
	1-6	Any defect in the CRANKSHAFT (bearing) and/or does the PISTON seize up?	Disassemble the whole engine. Breakage of the bearings of the CRANKSHAFT and ROD, CONNECTING, and/or problem such that the PISTON seizes up are likely.		
PLUG and COIL	2-1	Is the STOP SWITCH ON ?	Yes 2-2	Switch the STOP SWITCH to ON.	
	2-2	Remove the PLUG, SPARK and ground it. Does it ignite if the RECOIL STARTER is pulled?	Yes 3-1	No 2-3	
	2-3	Is the plug gap within $0.70 \sim 0.80$?	Yes 2-4	Adjust the plug gap within the criterion by moving the outer electrode. Replace it with a new one if necessary.	
	2-4	Is the PLUG dirty with carbon and/or gasoline?	No 2-5	Clean the PLUG with gasoline and dry it. Remove carbon, etc. by a wire brush. After this clean the PLUG with gasoline again and dry it.	
	2-5	Is the gap between the COIL and FLYWHEEL within (0.3 ± 0.1) ?	Yes 2-6	Adjust the gap within 0.3 ± 0.1 . See P. 18.	
	2-6	Does a new grounded PLUG ignite?	Yes Start the engine.	No 2-7	
	2-7	Replace the IGNITION COIL with a new one.	Replace the IGNITION COIL with a new one.		
Fuel	3-1	Any gasoline in the TANK, FUEL ? Have you pushed the primer pump to feed the gasoline to the CARBURETOR?	Yes 3-2	Fill the TANK, FUEL with gasoline. Push the primer pump to feed the gasoline to the CARBURETOR.	
	3-2	Have you pull the RECOIL STARTER with the choke closed at low temperature? (The engine will not start with thick air-fuel mixture at low temperature.)	The engine has started.	The engine does not start. 3-3	
	3-3	Does the engine start by pulling the RECOIL STARTER with the throttle lever half-open?	The engine has started.	The engine does not start yet. 3-4	
	3-4	Are the fuel filter and/or tube clogged? Is the tube bent?	No trouble in the fuel passage. 3-5	Correct the causes of bad fuel flow. Replace faulty parts with new ones if necessary.	
	3-5	Is the gasoline fresh?	Yes 3-6	Gasoline stored in a bad way goes bad quickly. Old gasoline should be replaced with new one.	
	3-6	Disassemble the CARBURETOR to test it for the component parts being clogged up and/or deteriorated.	Clean the inside of the CARBURETOR, and replace wearout parts with new ones if necessary. See P.P. 26~27.		
Insufficient compression	4-1	Pull the RECOIL STARTER to check for proper compression in the combustion chamber.	Properly compressed 5-1	Compressed insufficiently. 4-2	
	4-2	Pull the RECOIL STARTER swiftly 10-20 times with the choke open to start the engine.	The engine has started.	Still compressed insufficiently. 4-3	
	4-3	Remove the PLUG. Pull the RECOIL STARTER swiftly 30-50 times. Screw the PLUG and start the engine.	The engine has started.	Still compressed insufficiently. 4-4	
	4-4	Remove the ROCKER COVER to check whether the valve clearance is within $0.08 \sim 0.40$ (criterion: $0.1 - 0.15$)	The valve clearance is within the criterion. 4-5	Adjust the valve clearance at 0.15 . See P. 21.	
	4-5	Test the CAMGEAR for any ablation of the cam top.	No ablation 4-6	Any ablation of the cam top needs replacing the CAMGEAR with a new one. See P.P. 19~21.	
	4-6	Is the CAMGEAR timing right? (The timing mark of the CAMGEAR faces down vertically when the PISTON is at the top dead center.)	Yes 4-7	Correct the bad CAMGEAR timing. See P.P. 19~21.	
	4-7	Disassemble the whole engine to check whether any carbon remains attached to the valve face and/or the inside of the combustion chamber.	No carbon attached 4-8	Remove any attached carbon, if any.	
	4-8	Test the CYLINDER bore and PISTON RING for marked ablation and/or damage.	No ablation or damage 5-1	Marked ablation and/or damage needs replacing the CYLINDER and/or PISTON RING with a new one.	
Unknown causes	5-1	Ask a serviceman without known cause of the engine trouble.			
Poor acceleration and output shortage of engine.	Work load	6-1	Is the engine overloaded?	Correct workload 6-2	Ask a serviceman for the correct workload.
	Fuel	6-2	No gasoline in the TANK, FUEL? Have you pushed the primer pump to feed the gasoline to the CARBURETOR?	Yes 6-3	Fill the TANK, FUEL with gasoline. Push the primer pump to feed the gasoline to the CARBURETOR.
		6-3	Are the fuel filter and/or tube clogged up? Is the tube bent?	No trouble in the fuel passage. 6-4	Correct the causes of bad fuel flow. Replace faulty parts with new ones if necessary.
		6-4	Is the inside of the AIR CLEANER dirty with dust and/or oil?	No 6-5	Dirty AIR CLEANER inside causes bad engine shaft revolution because air cannot be breathed well. See P.P. 36~37.

Trouble	Work order	Point to be checked	Action to be done		
			Without problem	With problem	
Poor acceleration and output shortage of engine	Fuel	6-5	Does air-fuel mixture leak from the mating faces of the CARBURETOR, INSULATOR etc.?	No 6-6	Investigate the leakage and correct it. Replace the packing, etc. with a new one if necessary.
		6-6	Disassemble the CARBURETOR to test it for the component parts being clogged up and/or deteriorated.	No trouble in the fuel passage 6-7	Clean the inside of the CARBURETOR. Replace wearout parts, such as the diaphragm with new ones. Replace the CARBURETOR with a new one if necessary. See P.P. 26~27.
	Valve train	6-7	Remove the ROCKER COVER to check whether the valve clearance is within 0.08-0.40 (criterion: 0.15).	The valve clearance is within the criterion 6-8	Adjust the valve clearance at 0.15. See P. 21.
		6-8	Test the CAMGEAR for any ablation of the cam top.	No ablation 6-9	Any ablation of the CAM top needs replacing the CAMGEAR with a new one. See P.P. 19~21.
		6-9	Is the CAMGEAR timing right? (The timing mark of the CAMGEAR faces down vertically when the piston is at the top dead center.)	Yes 6-10	Correct the bad CAMGEAR timing. See P.P. 19~21.
	Insufficient compression	6-10	Pull the RECOIL STARTER to check for proper compression in the combustion chamber while the engine stops. Does the compression seem to be insufficient?	No 6-11	Compressed insufficiently. Return to work order 4-2 to get the proper compression in the combustion chamber.
	Plug and Ignition	6-11	Does the PLUG ignite sufficiently?	Yes 6-12	The plug ignites insufficiently. Return to work 2-3 to get the sufficient spark.
	Cooling	6-12	Is the cooling air passage clogged up at its inlet with dirt? Has the engine over-heated consequently?	No 6-13	Remove the dirt to get the good cooling air flow.
	Unknown case	6-13	Ask a serviceman without known cause of the engine trouble (poor acceleration and/or output shortage).		
Abrasion and damage	7-1	Was it confirmed at the pre-operation check that the engine oil tank was filled with engine oil of 30-80cc?	Yes 7-2	If the oil level is over 80cc drain the oil from the engine oil tank or if less 30cc fill the oil tank with engine oil, to the level of 30-80cc. See P. 38.	
	7-2	Is the engine oil consumed over 5cc an hour?	No	7-3	
	7-3	Does the engine oil leak from the OIL CAP, etc.?	No 7-4	Perform work orders 8-1, 8-2 and 8-5 when a fairly large amount of leaked oil is found around the CAP, OIL.	
	7-4	Disassemble the whole engine. Test the CYLINDER bore for marked ablation and/or damage.	No ablation or damaged 7-5	Marked ablation and/or damage needs replacing the CYLINDER with a new one.	
	7-5	Test the PISTON for marked ablation and/or damage.	No ablation or damaged 7-6	Marked ablation and/or damage needs replacing the PISTON with a new one.	
	7-6	Test the PISTON RING for marked ablation.		Marked ablation needs replacing the PISTON RING with a new one. See P. 14.	
Oil leak from engine	Oil and engine care	8-1	Is the CAP, OIL tightened?	Yes 8-2	Tighten the CAP, OIL.
		8-2	Was the engine oil spilled onto the equipment at feeding and/or changing oil.	No 8-3	Be careful not to spill the engine oil around the equipment at feeding and/or changing. If spilled, wipe off the equipment.
		8-3	Is the inside of the AIR CLEANER cleaned before operation?	Yes 8-4	Be sure to clean the inside of the AIR CLEANER before operation. The inside of the AIR CLEANER easily gets dirty with the engine oil. See P.P. 36~37.
	Engine care	8-4	Is the OIL SEPARATOR in the AIR CLEANER loose?	No 8-5	If loose: - Fasten the OIL SEPARATOR to the bottom, or - Replace the OIL SEPARATOR with a new one (5933501600).
		8-5	Is the gasket (rubber packing) of the CAP, OIL stiff?	No 8-6	Replace the gasket with a new one (0213229990). A gasket used for a long time is likely to get stiff, which causes an oil leak.
		8-6	Is any screw in the engine loose?	No 8-7	Tighten loose screws again.
	Working surroundings	8-7	Is the operation being done in an unusual place and/or work method?	No 8-8	Operate the equipment in an appropriate way for the operation in an unusual place and/or work method. Ask a serviceman for the appropriate way.
	Unknown cause	8-8	Ask a serviceman without known cause of the oil leak.		
Clouds of white smoke come out of muffler during operation	Oil care	9-1	Was it confirmed at the pre-operation check that the engine oil tank was filled with engine oil of 30-80cc?	Yes 9-2	If the oil level is over 80cc drain the oil from the engine oil tank or if less 30cc fill the oil tank with the engine oil, to the level of 30-80cc. See P. 38.
	Working surroundings	9-2	Is the operation being done in an unusual place and/or work method?	No 9-3	Operate the equipment in an appropriate way for the operation in an unusual place and/or work method. Ask a serviceman for the appropriate way.
	AIR CLEANER care	9-3	Is the inside of the AIR CLEANER cleaned before operation?	Yes 9-4	Be sure to clean the inside of the AIR CLEANER before operation. The inside of the AIR CLEANER easily gets dirty with the engine oil. See P.P. 36~37.
	Others	9-4	Drive the engine at about 7000rpm for about 3 minutes. Has the white smoke disappeared?	Yes	No 9-5
	Oil consumption	9-5	Is the engine oil consumed over 5cc an hour?	No 9-6	Perform work orders 7-4 or below until the problem of the excess oil consumption is corrected. (Excess oil consumption may cause clouds of white smoke.)
	Unknown cause	9-6	Clouds of white smoke do not come out during operation with the oil consumption at 5cc or less an hour and in normal use. Check again that the equipment has been in operation in an appropriate place and work method. Ask serviceman for further information.		
Change in shape of AIR CLEANER	Engine care	10-1	Is the COVER, AIR CLEANER attached correctly?	Yes 10-2	Attach the COVER, AIR CLEANER correctly. A wrong COVER, AIR CLEANER attachment may cause a change in shape of the AIR CLEANER. See P. 9.
		10-2	Is the O-ring correctly placed between the CARBURETOR and PLATE, AIR CLEANER?	Yes 10-3	A wrong O-ring placement causes a change in shape of the PLATE, AIR CLEANER.
	Others	10-3	Does the PLATE, AIR CLEANER still remain changed in shape?	Replace the PLATE, AIR CLEANER with a new one.	

V. CHECK AND RECONDITIONING

Check and recondition the engine according to the essential criteria for reconditioning after the disassembly and cleaning.

the terms used in the criteria for reconditioning are described below:

1) Reconditioning

To repair, adjust, replace any wrong part of the engine, so that it works like a new one.

2) Required reconditioning

The point at which a part of the engine is thought that it does not function any more without being repaired because of its wear, breakage, and/or decreased function.

3) Usage limit

The point at which a part of the engine can not be used any more because of its poor performance and/or strength.

4) Gauge

The design dimension of new parts exclusive of its permissible dimensional deviation.

5) Adjustment accuracy

The accuracy of finished and/or adjusted dimension of a repaired part of the engine.

VI. CRITERIA FOR RECONDITIONING

Criteria for reconditioning of EH025-type engine

Part to be repaired		Gauge	Adjustment accuracy	Adjustment limit	Usage limit	Remarks	Tool	If not adjustable	
CYLINDER BLOCK	Bore diameter	$\phi 34$	+0.02 0	0.06	0.06		Cylinder gauge	Replacement	
	Inside diameter of valve guide	$\phi 3$	+0.025 +0.005	0.10	0.10	Diameter of central part	Inside micrometer		
PISTON	External diameter of skirt in thrust direction (4.5-8.2mm higher from bottom)	$\phi 33.98$	0 ~0.021	-0.04	-0.04		Micrometer	Replacement	
	Width of ring grooves	Top	1.0	+0.04 +0.02	+0.06	+0.06		Slide calipas	Replacement
		2nd	1.0	+0.03 +0.01					
		Oil	2.0	+0.03 +0.01					
	PIN hole	$\phi 8$	+0.005 -0.004	+0.03	+0.03			Replacement	
	Gap between PISTON and CYLINDER			0.02L ~0.061	0.1	0.1	At skirt bottom in piston thrust direction	Cylinder gauge, micrometer	Replacement
	Gap between ring grooves and rings	Top		0.03 ~0.07	0.12	0.12		Gap gauge	Replacement
2nd			0.02 ~0.06	0.12	0.12				
Oil			0.04 ~0.14	0.20	0.20				
Authorized tally of PISTON and PISTON PIN			0.004T ~0.011L	0.04	0.04		Micrometer		
PISTON RING	Closed gap	Top	0.10 ~0.25	0.8	0.8	Replace when the whole ring working face touches the CYLINDER.	Gap gauge	Replacement	
		2nd	0.10 ~0.25	0.8	0.8				
		Oil	0.10 ~0.60	0.8	0.8				
	Width	Top	1.0	-0.01 -0.03	-0.05	-0.05	Micrometer	Replacement	
		2nd	1.0	-0.01 -0.03	-0.05	-0.05			
Oil		2.0	-0.03 -0.11	-0.14	-0.14				
External diameter of PISTON	$\phi 8$		0 -0.006	-0.012	-0.012				

Part to be repaired	Gauge	Adjustment accuracy	Adjustment limit	Usage limit	Remarks	Tool	If not adjustable	
CAMGEAR	Height of cam top	23.23	±0.05	-0.6	-0.6		Slide calipas	Replacement
	Shaft bore diameter	φ5	+0.050 +0.010				Inside micrometer	Replacement
	Cam shaft diameter	φ5	0 -0.010				Micrometer	Replacement
	Gap between CAMSHAFT and acceptance hole		0.010 ~0.060				Inside micrometer Micrometer	Replacement
Intake/exhaust valve	External diameter of valve shaft Intake	φ3.0	-0.010 -0.025	-0.10			Micrometer	Replacement
	Exhaust	φ3.0	-0.035 -0.050					
	Gap between valve shaft and valve guide Intake		0.015 ~0.050	0.2	0.2	At the center of the valve guide	Inside micrometer Micrometer	Replacement
	Exhaust		0.040 ~0.075					
	Valve lift		3.0~3.2	2.6	2.6		Slide calipas	Cam replacement
	Valve clearance (in the cold)	0.15	±0.02	0.08~0.4			Gap gauge	
ROCKER ARM	External diameter of rocker shaft	φ4	0 ~0.010				Micrometer	Replacement
	Diameter of rocker arm hole	φ4	+0.012 0				Three-point Micrometer	Replacement
	Gap between rocker arm and rocker shaft		0 ~0.022L				Micrometer Three-point Micrometer	Replacement
Electricity	PLUG SPARK	NGK CMR6A						
	Electrode interval	0.75	±0.05		1.0		Gap gauge	
	Gap between coil and flywheel	0.3	±0.1				Gap gauge	
Fuel consumption l/hr	0.45 ~0.58				On full throttle at 7800rpm			
Engine oil amount l	0.08							
Engine oil consumption cc/hr	3		6				Checking	
Recommended engine oil	Automotive Oil SAE10W-30:Class SF or higher							
Oil change		1st change : 20h 2nd or later change: 50h						

VII. NOTICE

1) Cleaning of air cleaner element

- Clean the element to avoid an extremely short life as well as poor start, power, and drive of the engine.
- If the oil is attached to the elements, squeeze the oil out of them. The oil attached to the elements causes the outer parts as well as the air cleaner inside to be dirty by the oil.
- Remove the element(sponge), clean it with lukewarm water or mild detergent diluted by water, and dry it completely.
- Remove the element(felt), clean it with gasoline, and dry it completely.
- Wipe oil off the air cleaner cover and air cleaner plate breather.

2) Oil supply and change

- Remove dust and dirt around the oil filler, and unscrew the oil gauge integrated oil cap.
- Place the oil gauge integrated oil cap on a place where it can not get dirty with sand and/or dust. The dirty screwed back oil gauge integrated oil cap might cause poor oil circulation and/or ablations of the engine parts resulting in an engine failure.
- Be sure to wipe spilled oil off the space between the fuel tank and engine and start the engine. Operation without wiping the spilled oil causes oil spots because the spilled oil is absorbed from the cooling air intakes and scattered.
- Drained oil should be properly dealt with according to the law. Do not discard it in a garbage bag, to the ground, and/or drainage ditches. Ask a store where you have bought the oil for unclear points about the disposal.
- Check and/or change the oil periodically(change it once six months).
The oil deteriorates naturally.

3) Fuel

- Do not use mixed gasoline(gasoline mixed with the engine oil). The mixed gasoline might cause carbon sedimentation resulting in an engine failure.
- Use of old fuel causes a poor engine start.

4) Operation

- Operation with the engine being inverted or protector being upward might cause clouds of white smoke coming out of the muffler.
- Open the throttle one thirds and start the warmed engine if it cannot easily start again.

5) Storage

- Store the equipment with the engine in an upright position in spite of its storage period.
- Tell your users the correct storage way above.

VIII. CARE AND STORAGE

Care described below shows the standard procedure required at the correct engine use under usual conditions. Therefore, it will not give you any guarantee such that care is not necessary up to the indicated times. An air cleaner cleaning, for example, is necessary every several (not ten) hours a day during operation in a dust-laden environment.

1) Daily check and care (every 10 hours)

Check and care	Reason
(1) Parts cleaning	(1) The dusty air cleaner element might cause poor engine drive. Also, the oil attached air cleaner element causes not only the inner but also outer parts to be dirty by the oil.
(2) Test the parts for being not seated. Tighten loose screws again if any.	(2) The parts not seated causes vibration of the engine and/or oil leaks.
(3) Test the fuel pipe for coming away and/or bend.	(3) The coming away and/or bent fuel pipe causes a fuel leak and/or poor engine start.
(4) Checking and cleaning of the PLUG, SPARK.	(4) The bad PLUG, SPARK causes poor power and/or engine start.
(5) Check the oil quantity. If short supply supplementary oil. ※	(5) The engine might seize up in operation with lack of the oil.

※A pre-operation check should be done.

2) Check and care after initial 20-hour use

Check and care	Reason
(1) Oil change	To remove the oil that has initially got dirty.

3) Check and care after every 50-hour use

Check and care	Reason
(1) Oil change	(1) The dirty oil accelerates ablation of the parts.
(2) Fuel filter cleaning	(2) The dirty fuel filter causes the fuel not to be supplied to the CARBURETOR resulting in a poor engine start.

4) Check and care after every 200-hour use

Check and care	Reason
(1) Overhaul and cleaning	(1) If not overhauled the power and drive get poor.
(2) Fuel pipe replacement	(2) A fuel leak is dangerous.

5) Long term nonuse of engine

- (1) Perform procedure 1) and 2).
- (2) Drain the fuel from the TANK, FUEL and CARBURETOR.
- (3) To prevent rust of the inside of the CYLINDER, pour oil of about 2cc from the CARBURETOR attaching screw hole, pull the RECOIL STARTER starting knob slowly 2 to 3 times, and screw the PLUG, SPARK.
- (4) Pull the RECOIL STARTER starting knob slowly and stop pulling at the first heavy movement (just before the pressure top dead center).
- (5) Cover the equipment and store it in an upright position in a dustless place.

IX. CHECK, DRAINAGE AND FEEDING OF ENGINE OIL

Recommended engine oil : Auto motive oil SAE 10W-30; Class SF or higher (Automotive 4-stroke engine oil)

1. CHECK

Place the equipment horizontally as shown in the figure below. Unscrew the oil gauge integrated CAP,OIL and check whether the oil level is within the upper and lower limits in the oil tank.

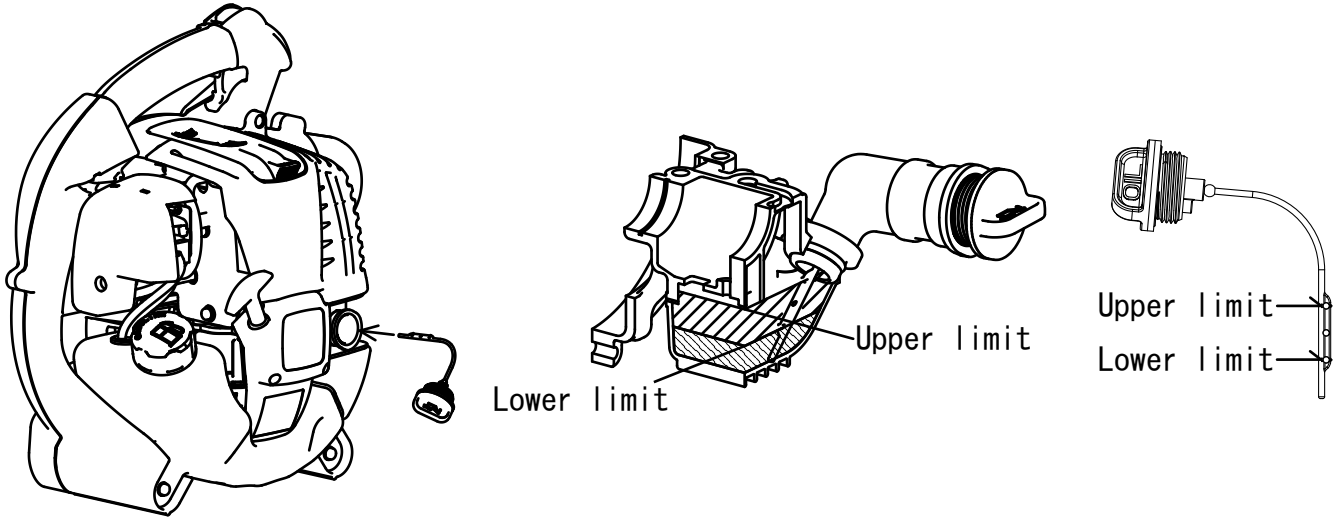

2. DRAINAGE

Make sure that the CAP,TANK FUEL is fastened. Tilt the equipment as shown in the figure below to drain the oil from the oil tank. Receive it in an oil pan.

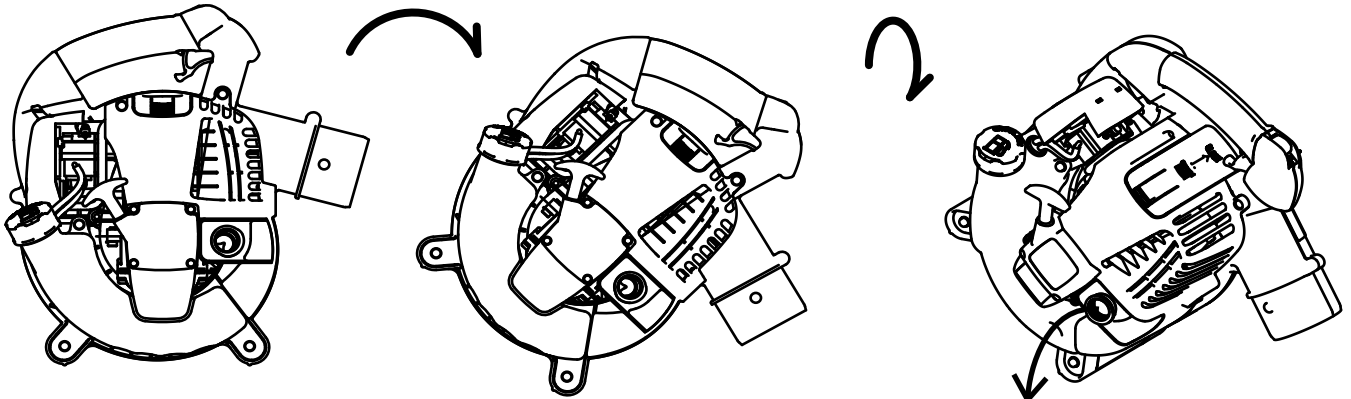

3. FEEDING

Place the equipment vertically (with the PROTECTOR downward) as shown in the figure below to feed the engine oil to the oil tank to the circular shelf level (upper limit). Too much fed oil causes oil spots and/or clouds of white smoke.

