

Owner's Manual & Assembly Instructions

V01et

Model No. NP10867

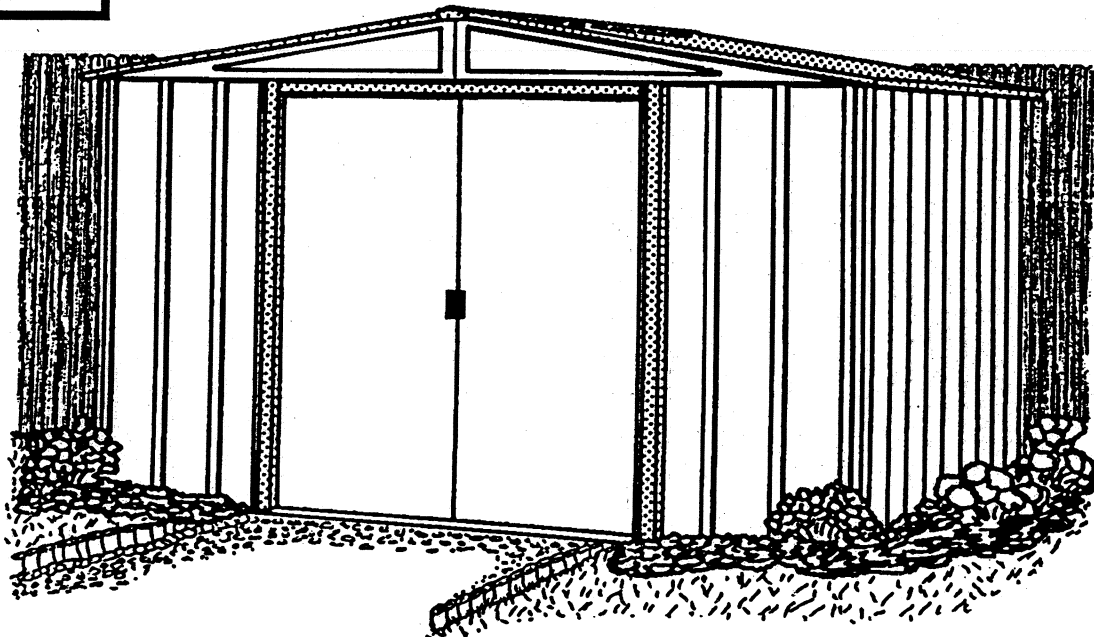

Missing Parts, Questions on Assembly?

**Call: 1-800-851-1085 or
assist@arrowsheds.com**

**Do not return to dealer, they are not
equipped to handle your requests.**

718000113

Storage Area: 74 Sq. Ft. 444 Cu. Ft.
6,9 m² 12,6 m³



CAUTION: SOME PARTS HAVE SHARP EDGES. CARE MUST BE TAKEN WHEN HANDLING THE VARIOUS PIECES TO AVOID A MISHAP. FOR SAFETY SAKE, PLEASE READ SAFETY INFORMATION PROVIDED IN THIS MANUAL BEFORE BEGINNING CONSTRUCTION. WEAR GLOVES WHEN HANDLING METAL PARTS.

BUILDING DIMENSIONS * Size rounded off to the nearest foot

*Approx. Size	Base Size	Exterior Dimensions (Roof Edge to Roof Edge)			Interior Dimensions (Wall to Wall)			Door Opening	
		Width	Depth	Height	Width	Depth	Height	Width	Height
10' x 8'	121" x 92 3/4"	123 1/4"	95 1/4"	77 7/8"	118 1/4"	90"	76 5/8"	55 1/2"	65"
3,0 m x 2,3 m	307,3 cm x 235,6 cm	313,1 cm	241,9 cm	197,8 cm	300,4 cm	228,6 cm	194,6 cm	141,0 cm	165,1 cm

BEFORE YOU BEGIN....

A03

Owner's Manual

Before beginning construction, check local building codes regarding footings, location and other requirements. Study and understand this owner's manual. Important information and helpful tips will make your construction easier and more enjoyable.

Assembly Instructions: Instructions are supplied in this manual and contain all appropriate information for your building model. Review all instructions before you begin, and during assembly, follow the step sequence carefully for successful results.

Flooring and Anchoring: Your storage building must be anchored to prevent wind damage. A base is necessary to construct a square and level building. Anchoring and base materials are not included with your building. We recommend the combined use of an **Arrow Floor Frame Kit** and an **Arrow Anchoring Kit** as an effective method of securing your building to the ground (Available at your local dealer, Arrow's website arrowsheds.com or call Arrow's Customer Service department 1-800-851-1085) or you may construct a base and anchoring system of your choice. Your assembly instructions provide information on a few methods commonly used to secure and level a storage building.

Parts and Parts List: Check to be sure that you have all the necessary parts for your building.

- All part numbers can be found on the parts. All of these numbers (before the -) must agree with the numbers on the Parts List page.

- If you find that a part is missing, include the model number of your building and contact:

Arrow Shed, LLC Customer Service Department
1101 North 4th Street Breese, Illinois 62230

1-800-851-1085 or assist@arrowsheds.com

- Separate contents of the carton by the part number while reviewing parts list. The first few steps show how to join related parts to make larger sub assemblies which will be used later.

- Familiarize yourself with the hardware and fasteners for easier use during construction. These are packaged within the carton. Note that extra fasteners have been supplied for your convenience.

PLAN AHEAD...

A04

Watch the Weather: Be sure the day you select to install your building is dry and calm. Do not attempt to assemble your building on a windy day. Be careful on wet or muddy ground.

Teamwork: Whenever possible, two or more people should work together to assemble your building. One person can position parts or panels while the other is able to handle the fasteners and the tools.

Tools and Materials: These are some basic tools and materials you will need for the construction of your building. Decide which method of anchoring and the type of base you wish to use in order to form a complete list of the materials you will need.

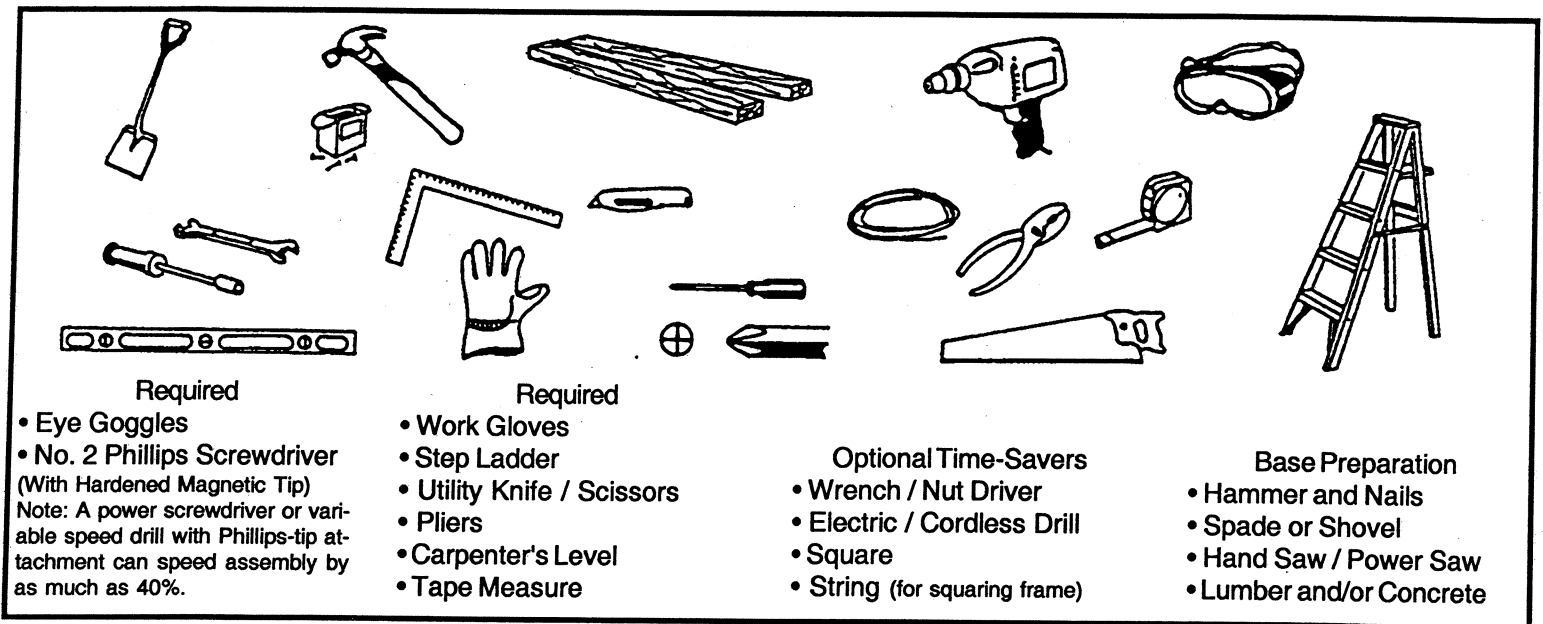

Selecting and Preparing Your Site: Before assembly, you will want to decide on a location for your building. The best location is a level area with good drainage.

- Allow enough working space for ease of moving parts into position during assembly. Be sure there will be enough space at entrance for doors to open fully and enough space around the building to be able to fasten the panel screws from the outside.

- Before you begin the first steps in assembling your parts, a base should be constructed and an anchoring system should be ready to use.

SAFETY FIRST...

A05

Safety precautions are important to follow throughout the construction of your building.

•Care must be taken when handling various pieces of your building since some contain sharp edges. Please wear work gloves, eye protection and long sleeves when assembling or performing any maintenance on your building.

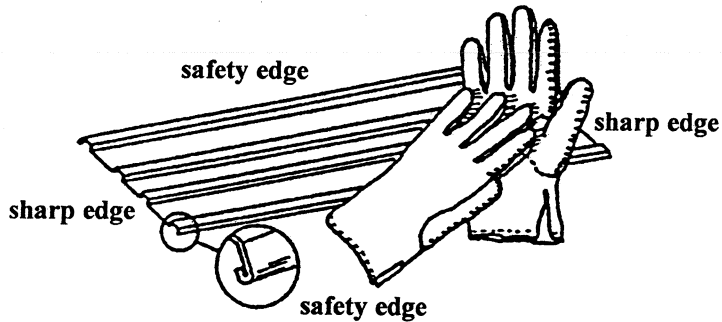

•Keep children and pets away from worksite to avoid distractions and any accidents which may occur.



•Never concentrate your total weight on the roof of the building. When using a step ladder make sure that it is fully open and on even ground before climbing on it.

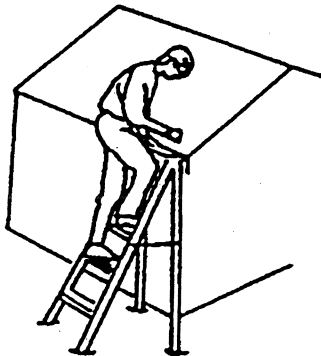

•Practice caution with the tools being used in the assembly of this building. Be familiar with the operation of all power tools.

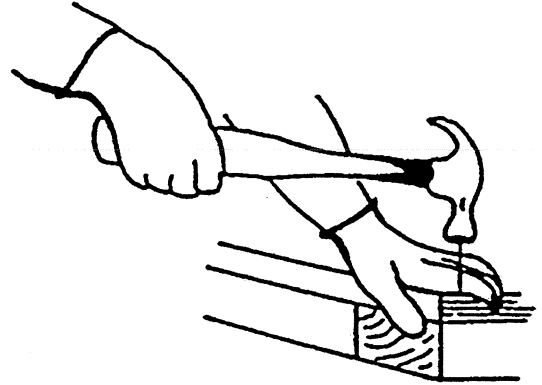

•Do not attempt to assemble the building if parts are missing because any building left partially assembled may be seriously damaged by light winds. Call 1-800-851-1085 or assist@arrowsheds.com

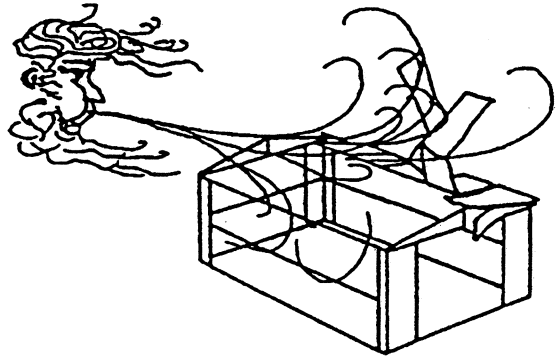

•Do not attempt to assemble the building on a windy day, because the large panels acting as a "sail", can be whipped about by the wind making construction difficult and unsafe.

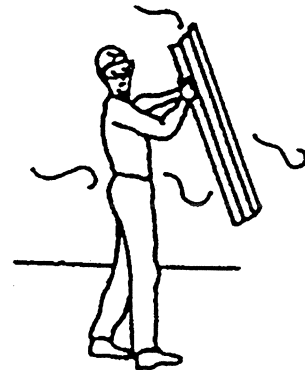

CARE & MAINTENANCE....

A06

Finish: For long lasting finish, periodically clean and wax the exterior surface. Touch-up scratches as soon as you notice them on your unit. Immediately clean the area with a wire brush; wash it and apply touch-up paint per manufacturer's recommendation.

Roof: Keep roof clear of leaves and snow with long handled, soft-bristled broom. Heavy amounts of snow on roof can damage building making it unsafe to enter. In snow country, Roof Strengthening Kits are available for most Arrow Buildings for added protection against heavy snow accumulation. Contact **Arrow** as outlined on the Ordering Accessories page to place an order.

Doors: Always keep the door tracks clear of dirt and other debris that prevent them from sliding easily. Lubricate door track annually with furniture polish or silicone spray. Keep doors closed and locked to prevent wind damage.

Fasteners: Use all washers supplied to protect against weather infiltration and to protect the metal from being scratched by screws. Regularly check your building for loose screws, bolts, nuts, etc. and retighten them as necessary.

Moisture: A plastic sheet (vapor barrier) placed under the entire floor area with good ventilation will reduce condensation.

Other Tips....

- Wash off inked part numbers on coated panels with soap and water.
- Silicone caulking may be used for watertight seals throughout the building.

Do not store swimming pool chemicals in your building. Combustibles and corrosives must be stored in air tight approved containers.

Keep this Owner's Manual and Assembly Instructions for future reference.

ACCESSORIES...

A07

ROOF STRENGTHENING (heavy snow load) KITS

Extra roof beams and gable braces designed for added protection against heavy snow accumulation. Increases the strength of your roof by 50%.

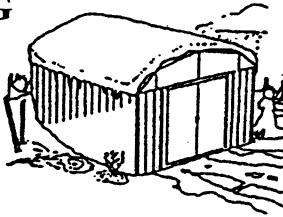

FLOOR FRAME KITS

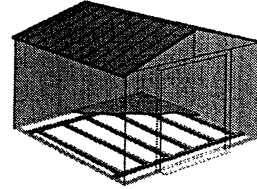

MODELS FB47410, FB5465, FB106-A
FB109-A and FB1014-A

A simple new floor frame system made of heavy-duty, hot-dipped galvanized steel. Use as base for plywood, sand or stone.

ANCHOR KITS

Model No. AK4

Anchor Kit contains heavy-duty steel augers, 60' (18 m) of steel cable and 4 cable clamps. No digging or concrete pouring, just insert cable under roof, over roof beams, into augers and twist augers into the ground. For buildings larger than 10'x9' (3,0 m x 2,6 m), use 2 kits.

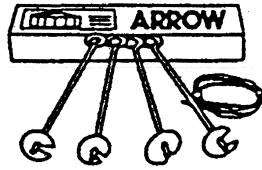

Model No. AK100

New concrete anchor system permits anchoring any size Arrow building directly to a concrete slab. Each kit contains heavy-duty, hot-dipped galvanized steel corner gussets and perimeter clips which fit over the floor frame and lag bolt into a concrete slab. Full assembly instructions and a 1/4" masonry drill bit are included.

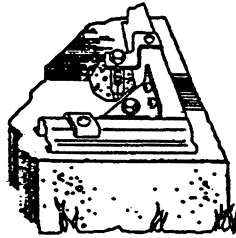

ATTIC KIT / WORKBENCH KIT

Model No. AT101

Heavy-duty galvanized steel bars that fit all 10' (3,0 m) wide Arrow buildings. They install quickly and easily to help organize space and create more useable space as an attic or workbench. Will hold up to 250 lbs. (113 kg) evenly distributed.

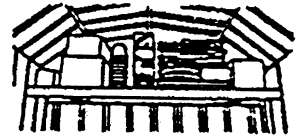

Some drilling required to fit buildings without mid-wall bracing.

Model No. AK600

Earth Anchor Kit anchors any size Arrow building to the ground. Each kit contains heavy duty, hot-dipped galvanized steel corner gussets and 4 earth anchors.

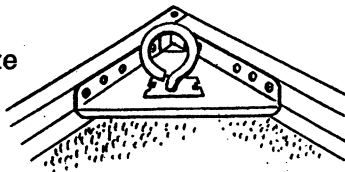

TOOL HANGING RACK

Model No. TH100

The perfect tool organizer. Twin 25 1/2" (64,8 cm) steel channels plus five heavy-duty snap-in hangers and a small tool holder for screwdrivers, pliers, etc. Holders slide along channel for fully adjustable spacing. Great for garage, basement, or the back of any door. Fits all Arrow storage buildings.

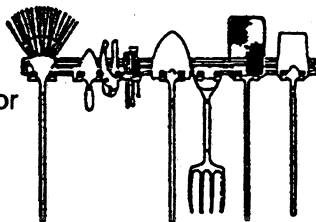

SHELF UNITS

Heavy-duty, galvanized steel shelf units help organize storage space. They easily mount on the wall or sit on the floor. Fits all Arrow buildings.*

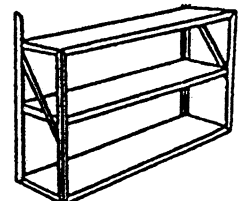
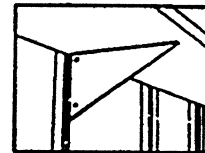
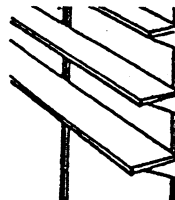

Model No. SS404

- Makes 8" to 12" (20,3-30,5 cm) wide shelves in any length.
- Brackets, braces, hardware included. Lumber is not included.

Model No. SS900-A

- Grey color
- 3 shelves
- Holds up to 85 lbs. (38 kg) (even weight distribution)

* Some drilling required to fit buildings without mid-wall bracing.

ORDERING ACCESSORIES....

A08

05/11

We recommend that you purchase accessory items from your local storage building dealer whenever possible; however, because the full line of accessories is not always available from all dealers, **Arrow** is offering them to you on a direct basis.

There are two ways to order Arrow Storage Building Accessories:

Option 1

Accessories can be purchased
through

arrowsheds.com

Option 2

Order accessories by telephone
using your MasterCard or Visa credit card.

Call toll free **1-800-851-1085**
(Customer Service).

Allow 2 weeks for delivery.

SPECIAL NOTE:

If your accessory is shipped via truck line a day time phone number is required to arrange delivery. If no one is available to sign for the delivery, you may be subject to a re-delivery charge assessed by the carrier.

Base

A09

The Base For Your Building

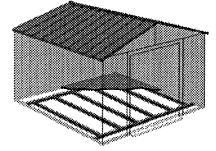

OPTION 1: ARROW FLOOR FRAME KIT: (Order No. FB109-A or 68385-A)

Arrow has the best base for your building in this simple kit. It keeps stored items above the ground.

This kit should be used with one of the following:

A. To support a plywood deck **B.** To be filled with sand. We recommend the combined use of

1. an **ARROW FLOOR FRAME KIT** and **2.** an **ARROW ANCHORING KIT** as an effective method of securing the building to the ground.

Allow 1 - 2 hours for construction.

OPTION 2: Wood Platform

If you decide to build your own base, be sure to select the appropriate materials.

These are the recommended materials for your base:

● 2 x 4's (38 mm x 89 mm) Pressure Treated Lumber

● 5/8" (15,5 mm) 4 x 8 (1220 mm x 2440 mm) Plywood-exterior grade **NOTE:** Pressure Treated Lumber must not be used where it will make contact with your storage building. The properties of Pressure Treated Lumber will cause accelerated corrosion.

If Pressure Treated Lumber comes in contact with your storage building your warranty will be voided.

● 10 & 4 penny Galvanized Nails ● Concrete Blocks (optional)

The platform should be level and flat (free of bumps, ridges etc.) to provide good support for the building. The necessary materials may be obtained from your local lumber yard.

To construct the base follow instructions and diagram.

Construct frame (using 10 penny galvanized nails)

Measure 16"/24" (40,6 cm/61,0 cm) sections to construct inside frame (see diagram)

Secure plywood to frame (using 4 penny galvanized nails)

Allow 6 - 7 hours for construction.

OPTION 3: Concrete Slab

The slab should be at least 4" (10,2 cm) thick. It must be level and flat to provide good support for the frame.

The following are the recommended materials for your base.

● 1 x 4's (19 mm x 89 mm) (will be removed once the concrete cures)

● Concrete ● Sheet of 6 mil plastic

● We recommend for a proper strength concrete to use a mix of:

1 part cement ● 3 parts pea sized gravel ● 2 1/2 parts clean sand

Prepare the Site/Construct a Base

1. Dig a square, 6" (15,2 cm) deep into the ground (remove grass).
2. Fill up to 4" (10,2 cm) in the square with gravel and tamp firm.
3. Cover gravel with a sheet of 6 mil plastic.
4. Construct a wood frame using four planks of 1x4 (19 mm x 89 mm) lumber.
5. Pour in concrete to fill in the hole and the frame giving a total of 4" (10,2 cm) thick concrete. Be sure surface is level.

Allow 3 - 5 hours for construction and a week for concrete curing time.

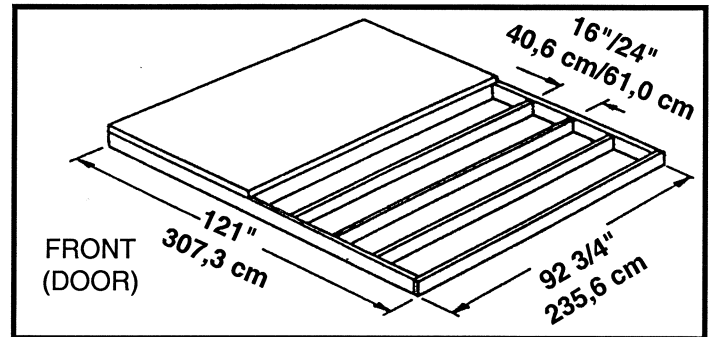

Note: Platform/Slab will extend 9/16" (1,4 cm) beyond floor frame on all four sides. Seal this 9/16" (1,4 cm) of wood with a roofing cement (not included), or bevel this 9/16" (1,4 cm) of concrete when pouring, for good water drainage.

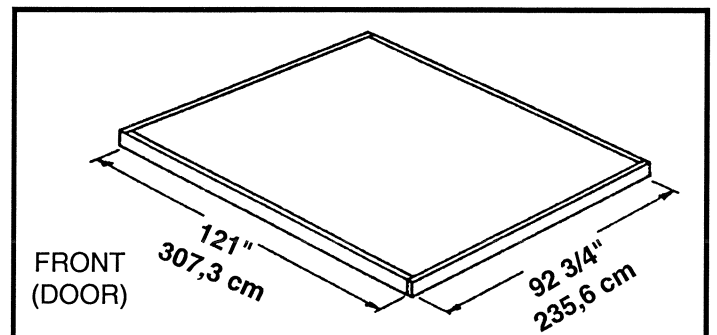

Note: Finished Slab dimensions, with lumber removed.

Anchoring

A10

Anchoring Down The Building

It is important that the entire floor frame be anchored after the building is erected.

Below are recommended ways of anchoring.

Arrow Anchoring Kit: (Model No. AK4 or 60298)

Recommended for use with **any** suggested base.

Contains: 4 Anchors with Cable, Clamps and installation instruction.

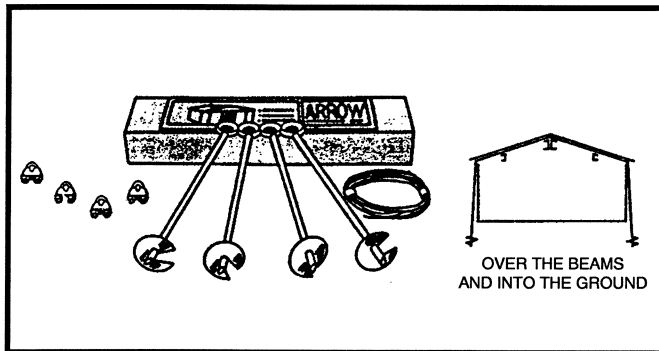

Anchoring into Wood/Post:

Use 1/4" (6 mm) Wood Screws. There are 1/4" (6 mm) dia. holes provided in the frames for proper anchoring.

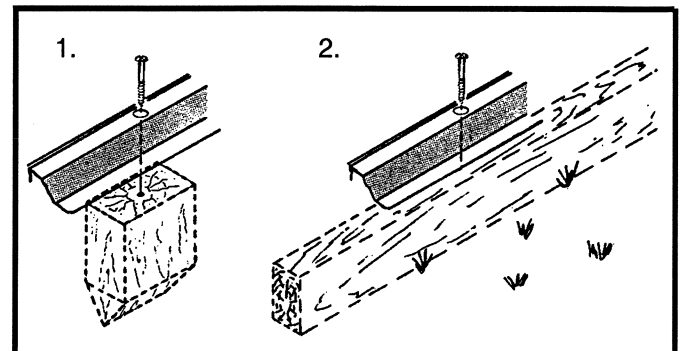

Arrow Anchoring Kit: (Model No. AK100 or 68383)

Recommended for use with the **concrete** base.

Contains: Corner gussets, perimeter clips, hardware, 1/4" masonry drill bit and installation instruction.

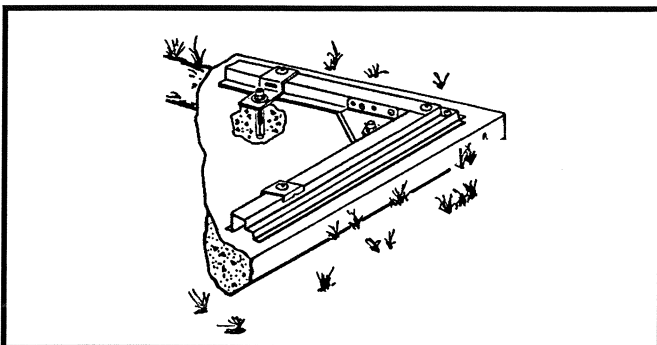

Anchoring into Concrete:

1. For poured concrete slab or footing or patio blocks: Use 1/4" x 2" (6 mm x 51 mm) Lag Screws.
2. For Anchor Post of Concrete poured after building is erected: Use 1/4" x 6" (6 mm x 152 mm) Lag Screws.

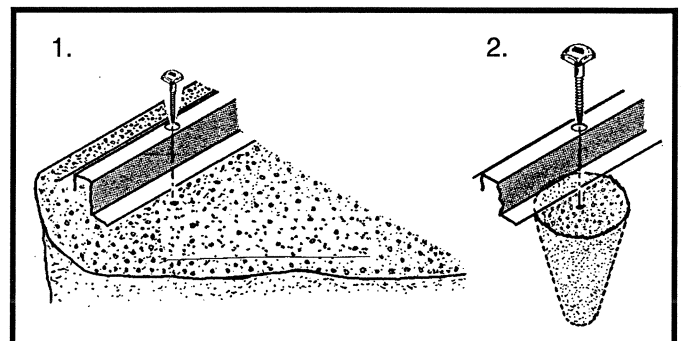

Hardware

A11

Remove from bag of screws
and save for the last step



65103
#8-32 Hex Nut (161)



65900A
#10Bx1/2" (13 mm)
Black Screw (8)
(Packed with Screws)



65923
#8-32x3/8" (10 mm)
Bolt (161)



65004
#8Ax5/16" (8 mm)
Screw (326)

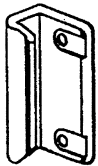

66045
Handle (2)

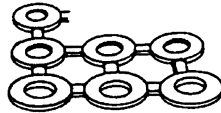

66646
Washer (369)
(10 sheets of 40)



65109
#8-32 Acorn Nut (4)
(Packed with Screws)

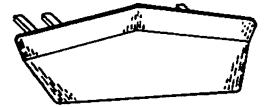

67468
Peak Cap (2)
(Arrow Logo)

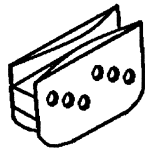

66769
Door Slide (4)

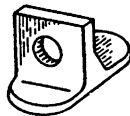

66382
Lower Door Guide (4)

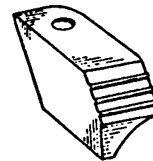

66183
Roof Trim Cap
(2 right & 2 left)

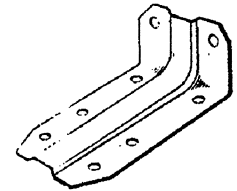

6228
Track Support (2)

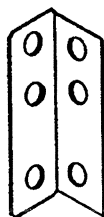

5971
Roof Beam Bracket (4)

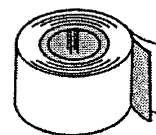

67293
Weather Stripping (1)

Parts List

V12et

Assembly Key No.	Part Number	Part Description	Quantity in Carton	Check List
1	3719	Door Handle Brace	2	
2	8200	Wall Panel (Side)	4	
3	9374	Front Wall Panel	2	
4	9365	Front Wall Channel	2	
5	5986	Rear Wall Angle	2	
6	6000	Right Gable	2	
7	6001	Left Gable	2	
8	10497	Horizontal Door Brace	4	
9	6300	Vertical Door Brace	2	
10	6403	Door Track Splice	1	
11	9366	Door Track	2	
12	6627	Wall Panel	6	
13	6529	Roof Panel	2	
14	6635	Gable Brace	2	
15	10477	Right and Left Doors	2	
16	7483	Roof Panel	4	
17	9370	Door Jamb	2	
18	9917	Rear Wall Channel	2	
19	8468	Right Roof Panel	2	
20	8469	Left Roof Panel	2	
21	8485	Left Side Roof Trim	2	
22	8840	Ridge Cap	1	
23	10470	Roof Beam	8	
24	8836	Right Side Roof Trim	2	
25	9922	Side Wall Channel	4	
26	8839	Side Wall Angle	4	
27	8486	Ridge Cap	1	
28	8934	Ramp	1	
29	9367	Front Floor Frame	2	
30	8936	Rear Floor Frame	2	
31	8937	Side Floor Frame	4	
32	8471	Corner Panel	4	
33	69835	Edge Trim (Green)	4	

Assembly by Key No.

A13et ctr

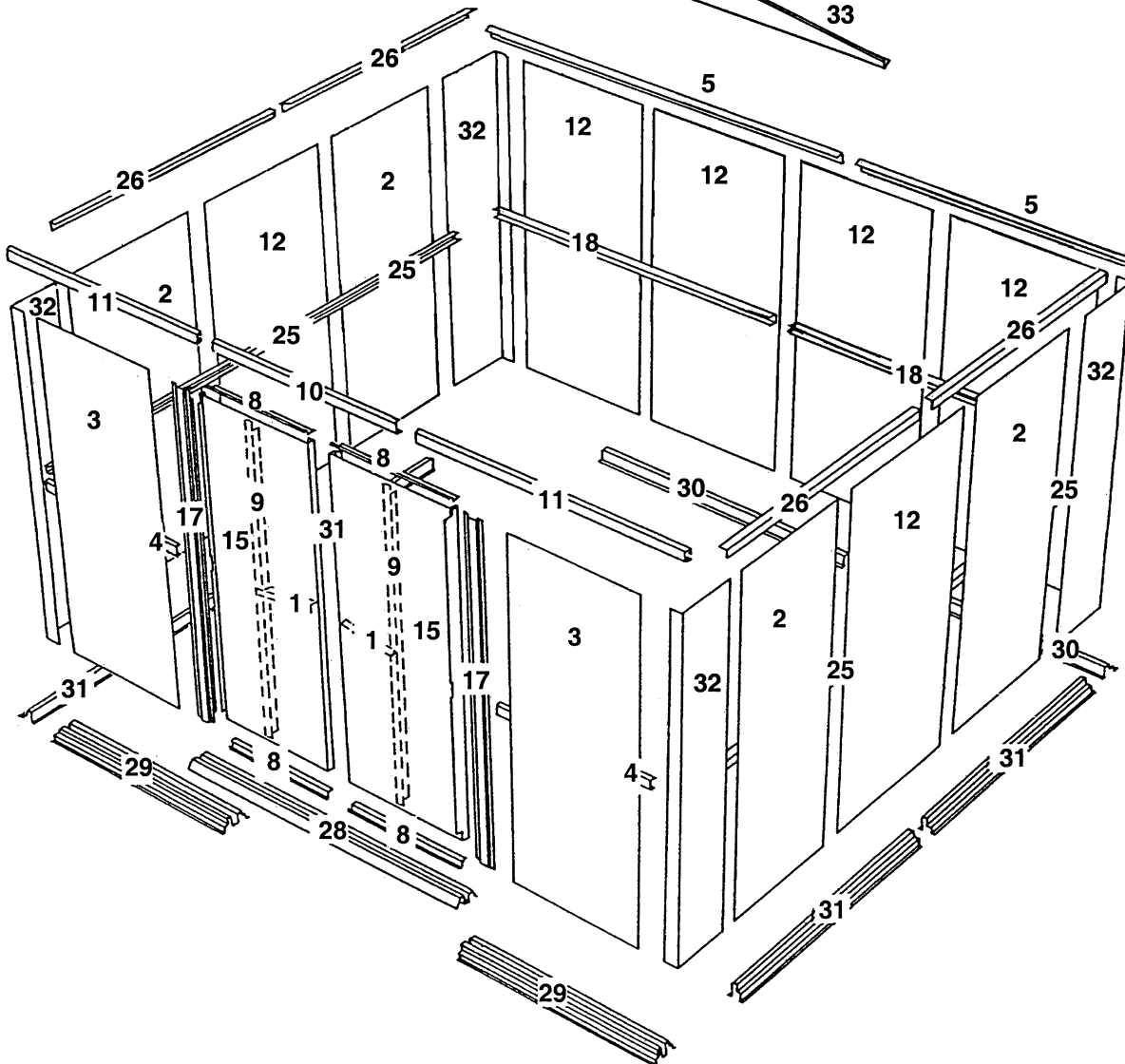
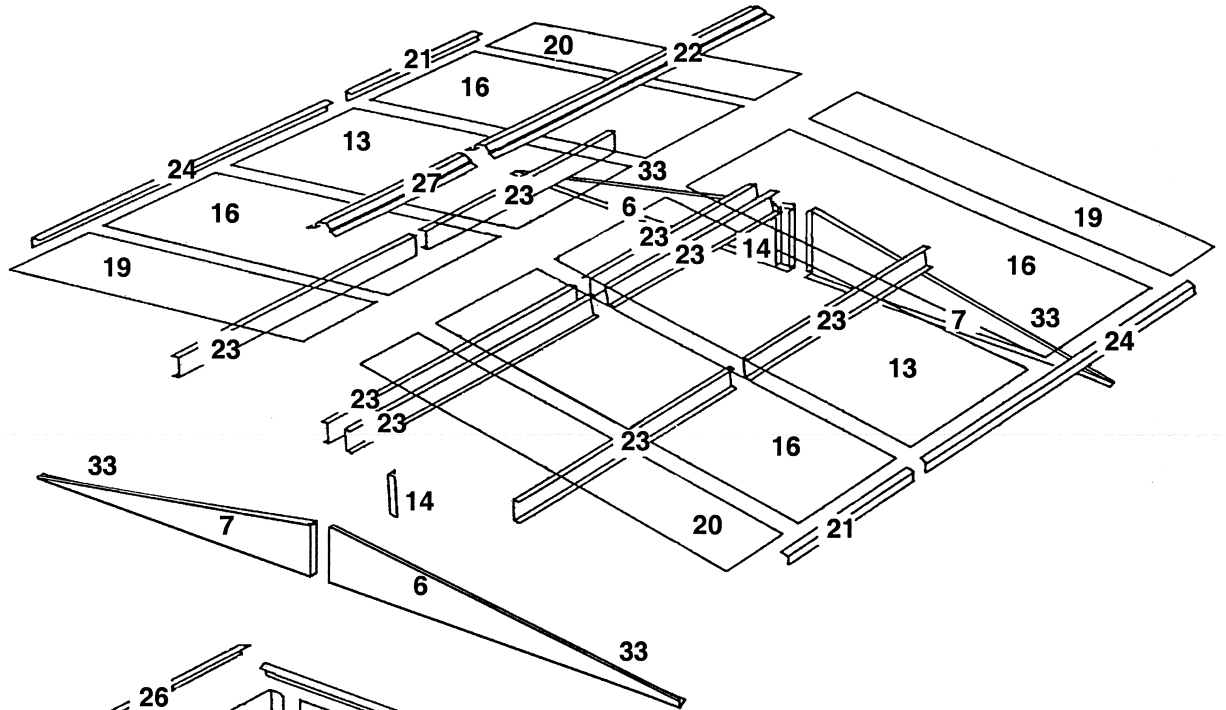

Step 1

A14ctr

● Parts Needed For ● Floor Frame Assemblies

- 8934 Ramp (1)
- 9367 Front Floor Frame (2)
- 8936 Rear Floor Frame (2)
- 8937 Side Floor Frame (4)



(8)



(13)

The front floor frame is made up of three pieces. The side floor frames and the rear floor frame are made up of two pieces. The holes in these pieces will align when the pieces are positioned with correct amount of overlap. The illustrations below show the proper overall length for the sides, rear and front. Proceed as follows:

1 Place the **front floor frames** as shown. Center the **ramp**, with drain holes facing outside, on top of the two front floor frames. Join the frames by inserting eight screws.

2 Overlap the **side floor frames** and the **rear floor frames** as shown. The holes in these pieces will align when the pieces are positioned with correct amount of overlap. See the illustrations below for the proper overall length of the side and rear floor frames. Join the frames by inserting four/five bolts into each frame set as shown.

3 Double check the length of each and set these pieces aside for later use.

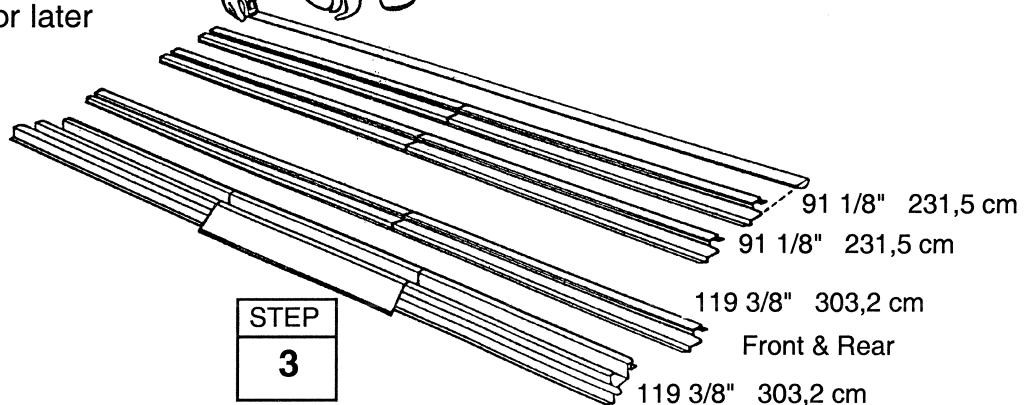
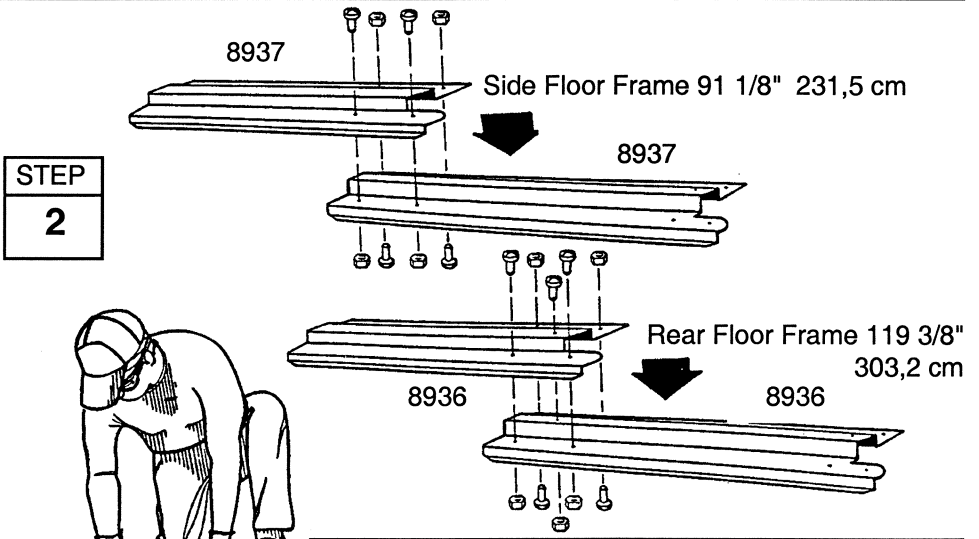
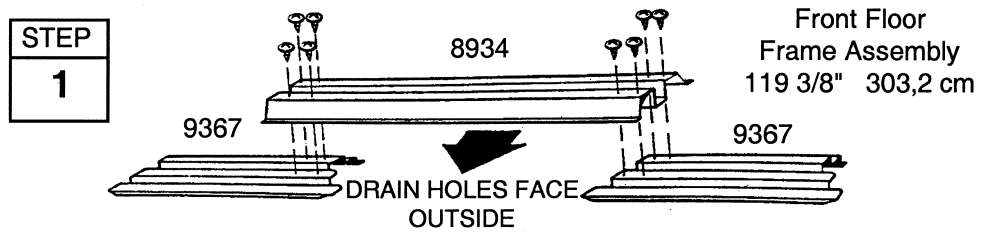
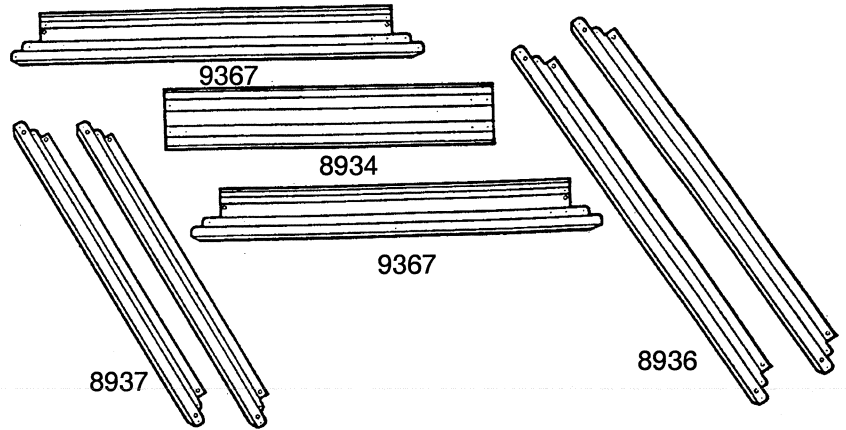

Step 2

A15 ctr

● Parts Needed For ● Frame Assemblies

- 5986 Rear Wall Angle (2)
- 9917 Rear Wall Channel (2)
- 9922 Side Wall Channel (4)
- 8839 Side Wall Angle (4)

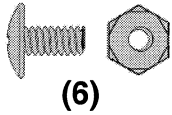

The main frame pieces reinforce the walls. These pieces will later be installed in the center and at the top edge of the side walls and the rear wall. Proceed as follows:

1 Overlap the **rear wall channel** pieces as shown in the figure and fasten the two pieces together with *one bolt in the center hole* (three holes will align).

2 Make two **side wall channels** by overlapping the side wall channel pieces as shown. Fasten each set together with *one bolt in the center hole* of each set.

3 Overlap the **rear wall angle** pieces as shown in the figure and fasten them together with *one bolt in the center hole*.

4 Make two **side wall angles** by overlapping the side wall angle pieces as shown. Fasten each set together with *one bolt in the center hole*.

5 Double check the length of each and set these pieces aside for later use.

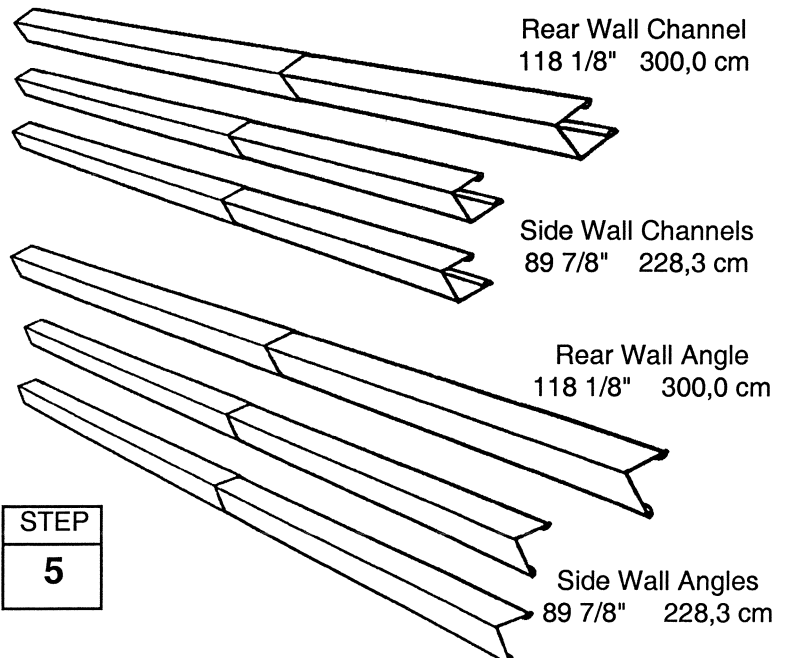
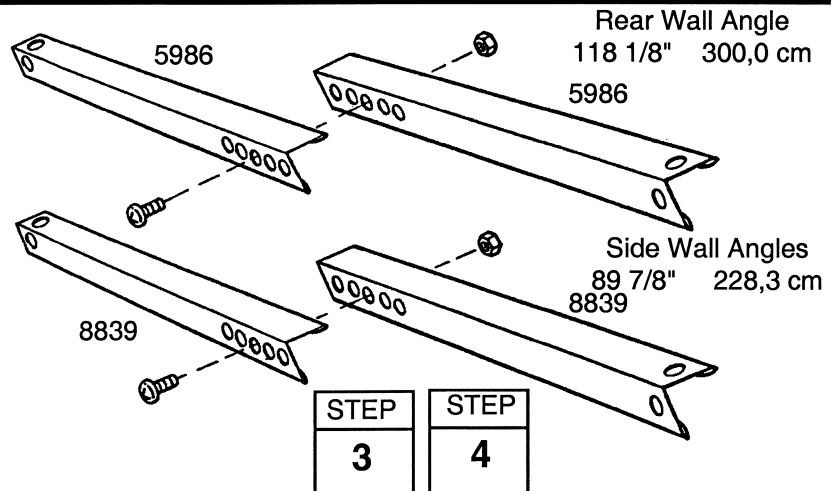
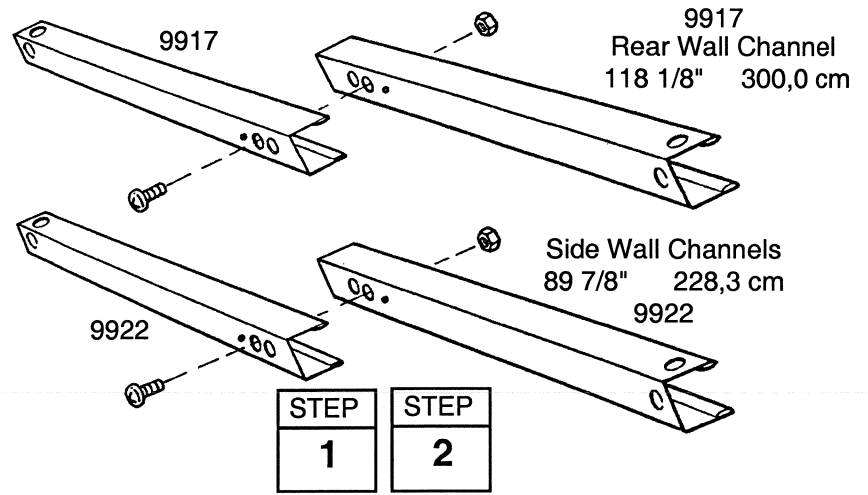

Step 3

D16 ctr

● Parts Needed For ● Roof Beam Assemblies

● 10470 Roof Beam (8)

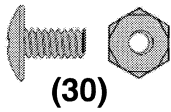

The roof beams join the two gables and support the roof panels. The main roof beam is made up of four pieces overlapped back to back at the center. The left and right roof beam assemblies are made up of two pieces.

Hint: These pieces are force-fitted, so you may have to press hard to join them together.

STEP
1

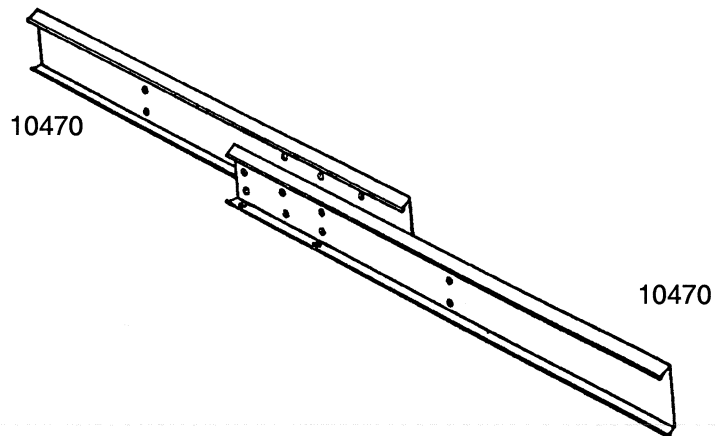

Roof Beam 91 7/8" 233,4 cm

1 Place the end of one roof beam inside a second roof beam so that the six holes in each piece align. Make four sets of roof beams by repeating this procedure. ***Do not insert bolts yet.***

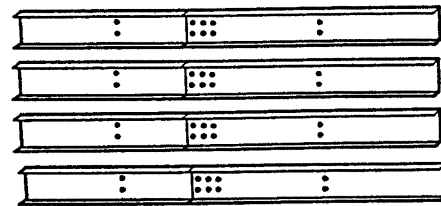

2 Take two of the pressed-together roof beams and join them as shown to form the main roof beam assembly. Hold the assembly together and fasten with 14 bolts. Build ***only one*** Doubled Beam Assembly.

STEP
2

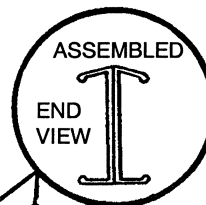

Build ***one*** Doubled Main Roof Beam Assembly for Peak in Roof

3 Fasten the other two pressed-together roof beams with eight bolts to make the left and right roof beam assemblies.

STEP
3

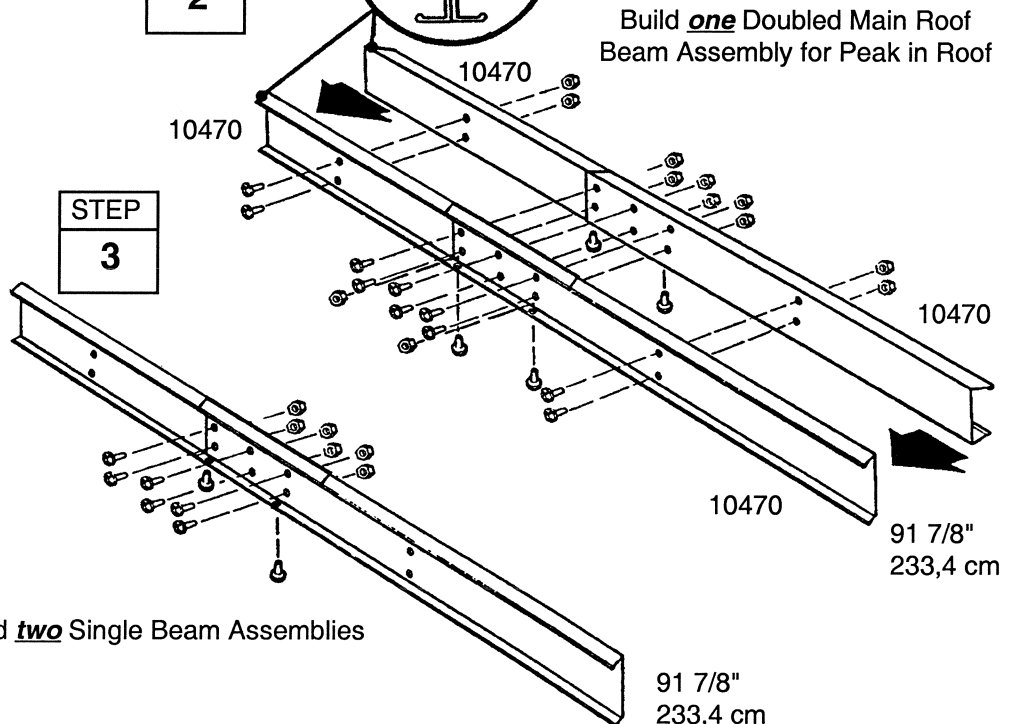

Build ***two*** Single Beam Assemblies

91 7/8"
233,4 cm

Step 4

A17 ctr

● Parts Needed For ● Door Track Assembly

- 6403 Door Track Splice (1)
- 9366 Door Track (2)

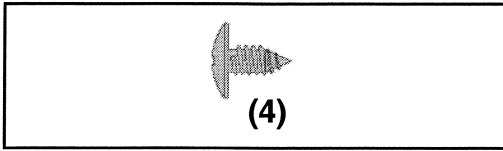

The door track assembly supports the sliding doors and reinforces the front wall. It is made up of three pieces.

1 Using the **door track splice**, (painted), join the **door track** (galvanized) pieces end-to-end as shown.

2 Insert four screws *from the underside only*.

Hint: The holes in the top side of the door track assembly are for fastening the gable to the top of the front wall in a later step.

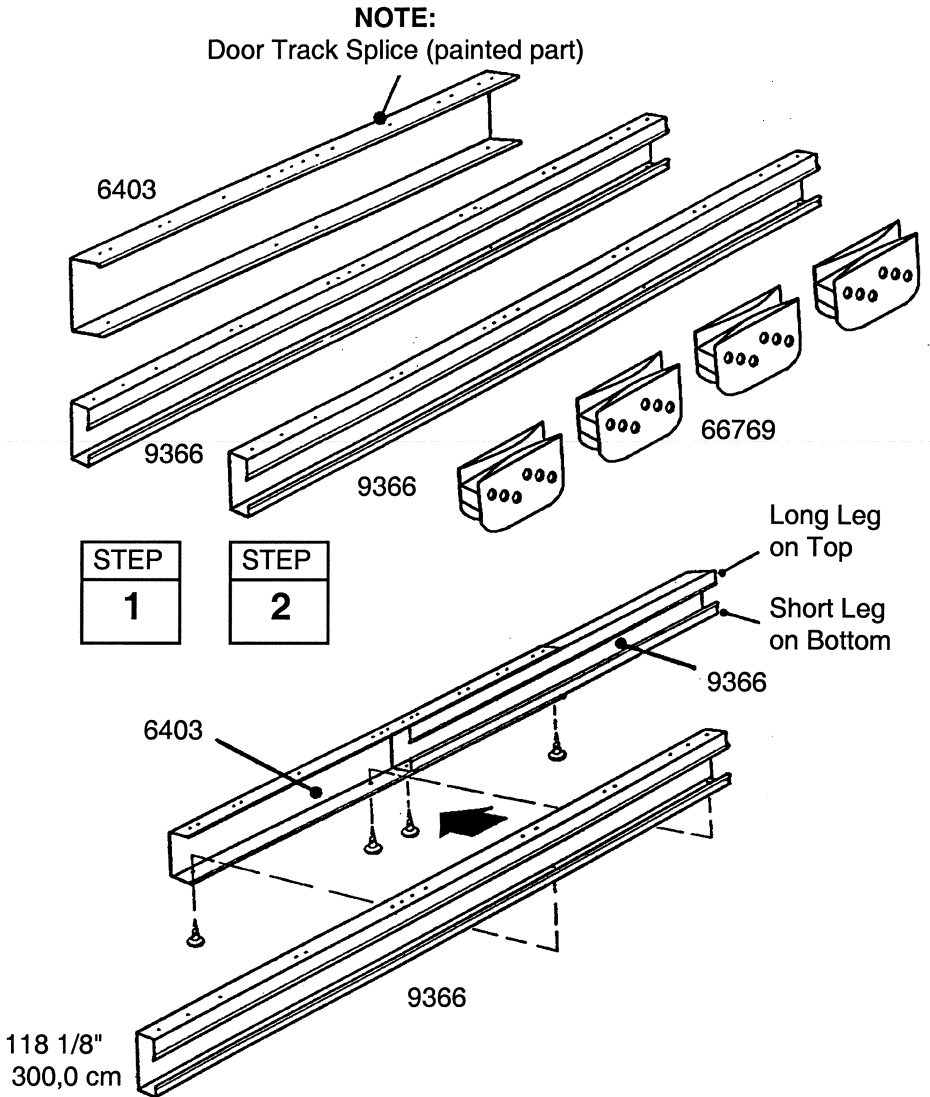

3 Position **door slides** onto the legs, from the end of door track assembly, as shown in the end view.

4 Set this piece aside for later use.

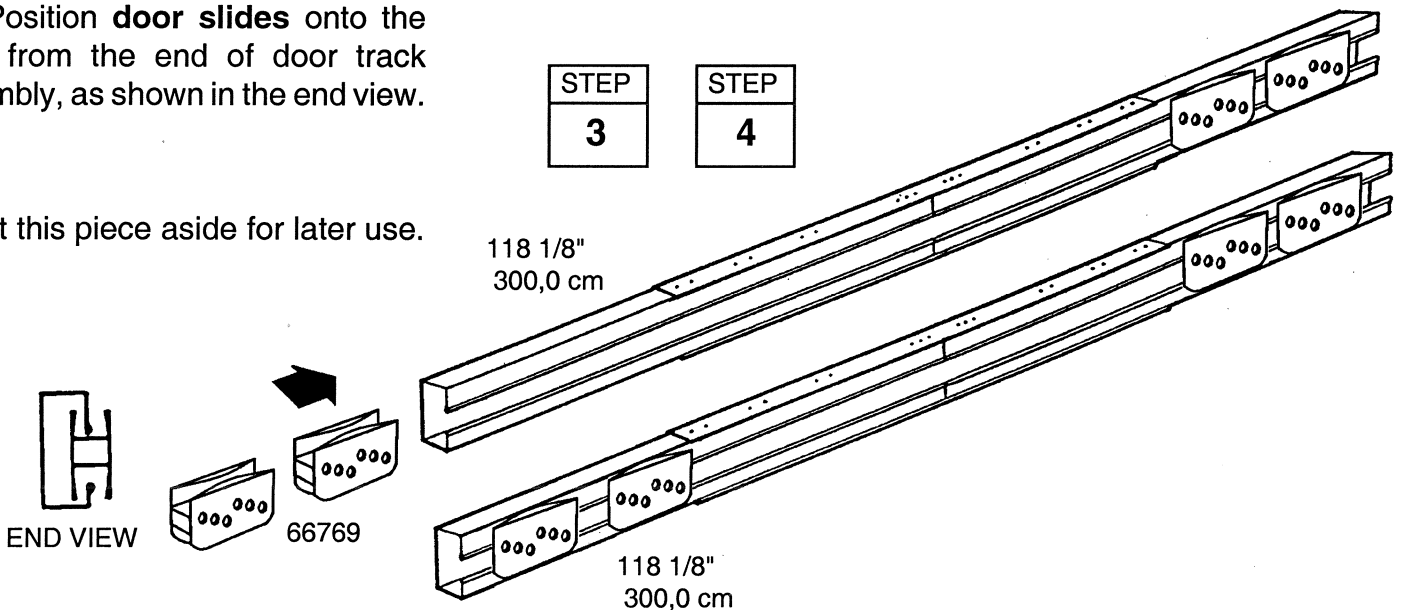

Step 5

A18ctr

● Parts Needed For ● Floor Frame

- Front Floor Assembly (1)
- Side Floor Assembly (2)
- Rear Floor Assembly (1)



(8)

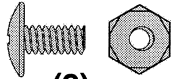

(2)

1 Assemble the four corners of the floor frame using two screws at each corner as shown. At the front corners fasten bolts through from the bottom with nuts on top.

STEP
1

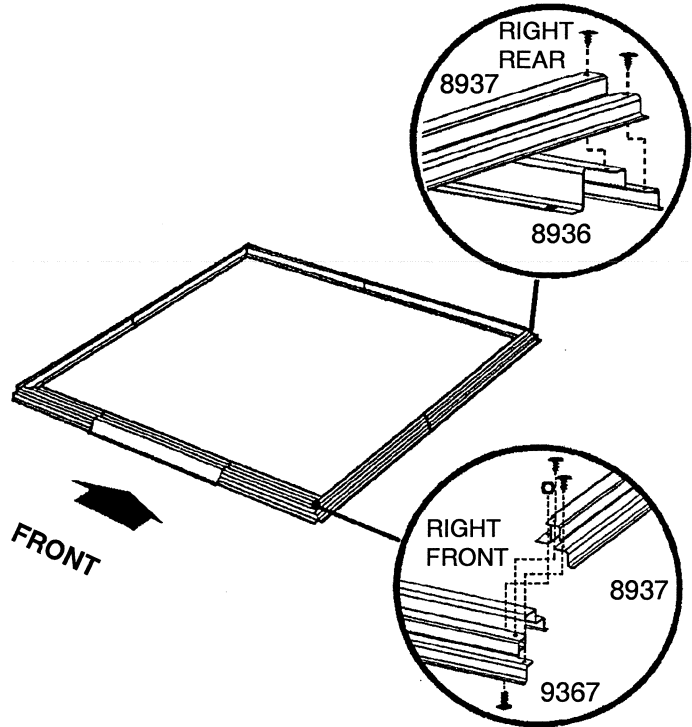

2 Measure the floor frame diagonally. When the diagonal measurements are equal, the floor frame is square.

NOTE

If using a wood platform or concrete slab do not fasten the floor frames to your base at this time. You will anchor the building after it is erected.

When Diagonal Measurements are Equal the Floor Frame is Square.

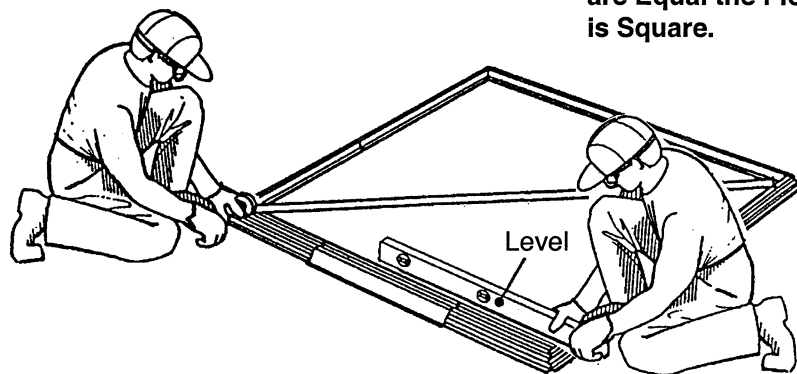

STEP
2

The floor frame *must be square and level* or holes will not align.

Step 6

U19 ctr

● Parts Needed For ● Corners

- 6627 Wall Panel (2)
- 9374 Front Wall Panel (2)
- 8471 Corner Panel (4)

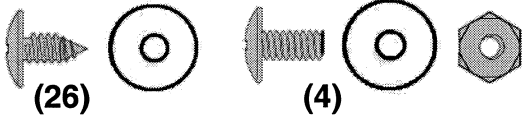

NOTE
The remainder of the building assembly requires many hours and more than one person. Do not continue beyond this point if you do not have enough time to complete the assembly today. A partially assembled building can be severely damaged by light winds.

Each screw and bolt in the wall requires a washer.



CORRECT



INCORRECT

1 Position a **corner panel** at the corner of the floor frame as shown. The widest part of each corner panel must be placed along the side of the building for all four corners. Fasten the corner panel to the floor frame with one screw.

Support the corner panel with a step ladder until a wall panel is attached.

2 Attach the **front wall panels** to the front corner panels, as shown. A small gap will exist between front wall panel and ramp.

3 Attach the **wall panels** to the rear corner panels, as shown.

NOTE
Be careful to install the correct panel in each position as shown

4 Double-check the part numbers of the wall panels, before proceeding.

The floor frame *must be square and level* or holes will not align.

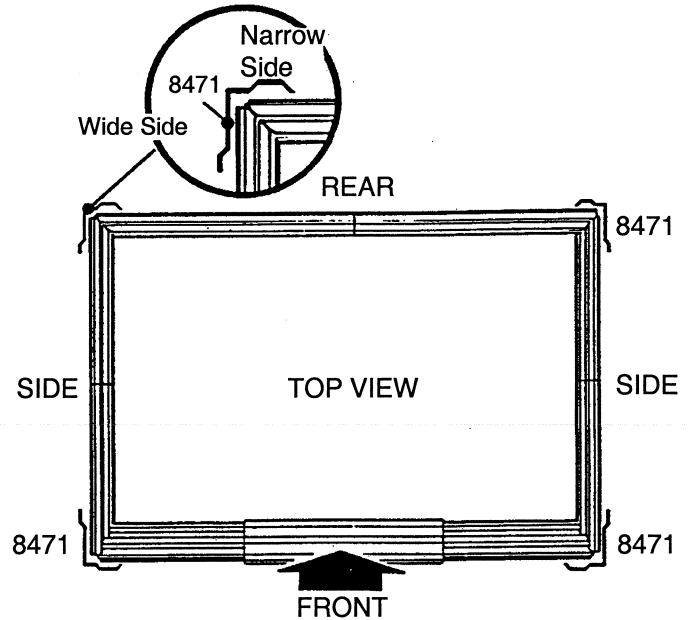

STEP
1

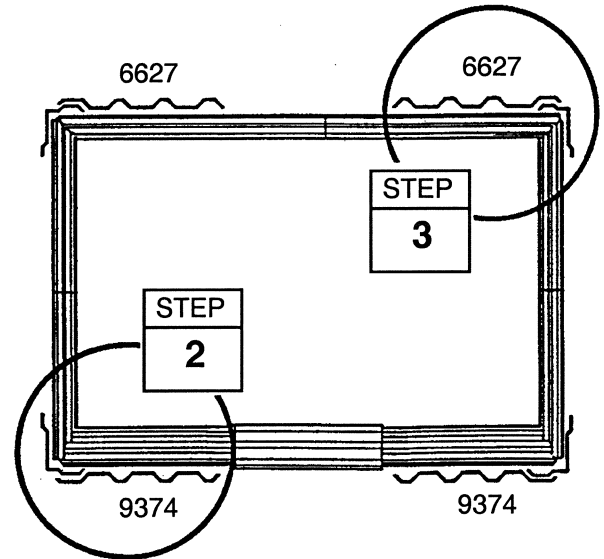

STEP
4

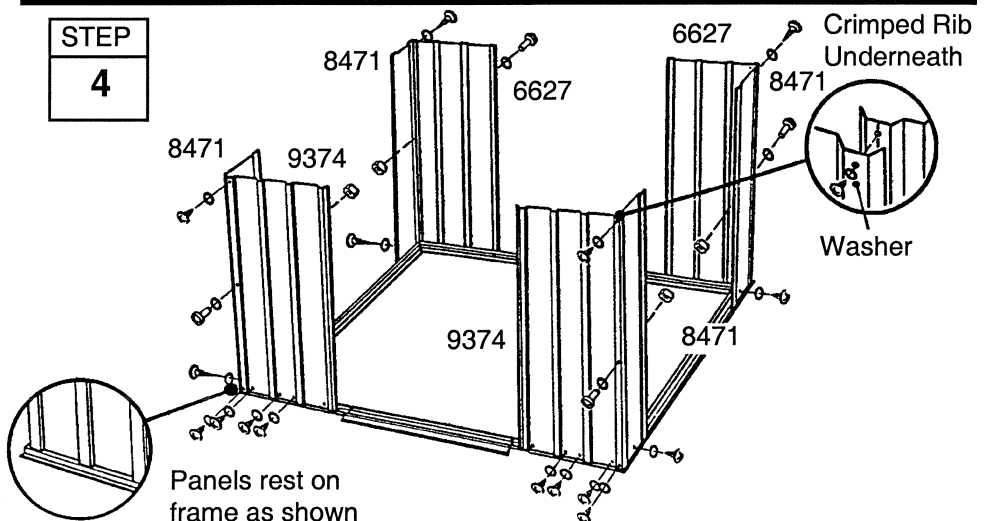

Panels rest on frame as shown

Step 7

A20 ctr

● Parts Needed For ● Frames

- Door Track Assembly (1)
- Rear Wall Angle Assembly (1)
- Side Wall Angle Assemblies (2)
- Rear Wall Channel Assembly (1)
- Side Wall Channel Assemblies (2)

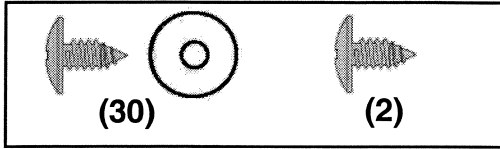

The main frame pieces give rigidity to the side walls and provide a surface for attaching the gables which support the roof.

1 Fasten the rear wall angle assembly across the inside top of the rear wall using screws.

2 Fasten the rear wall channel assembly across the middle of the rear wall using screws.

3 Fasten the side wall angles across the inside top of the side panels using screws. Side wall angles must overlap rear wall angle in corners.

4 Fasten the side wall channel assemblies across the middle of the side panels using screws. Fasten overlaps in rear corners with screws.

5 Fasten the door track assembly (holes on top) across the top of the front wall panels using screws. See the figure.

NOTE

The wall channels behind the front wall panels will be installed in a later step.

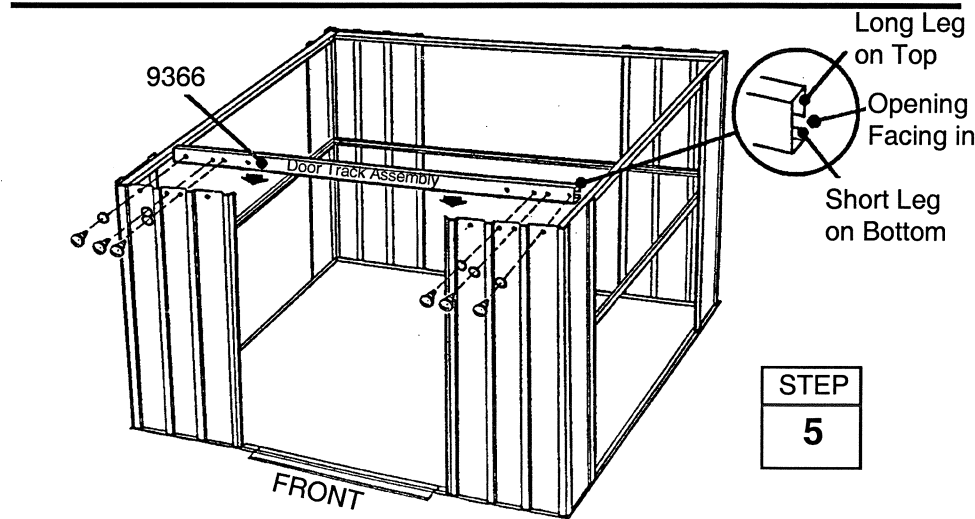
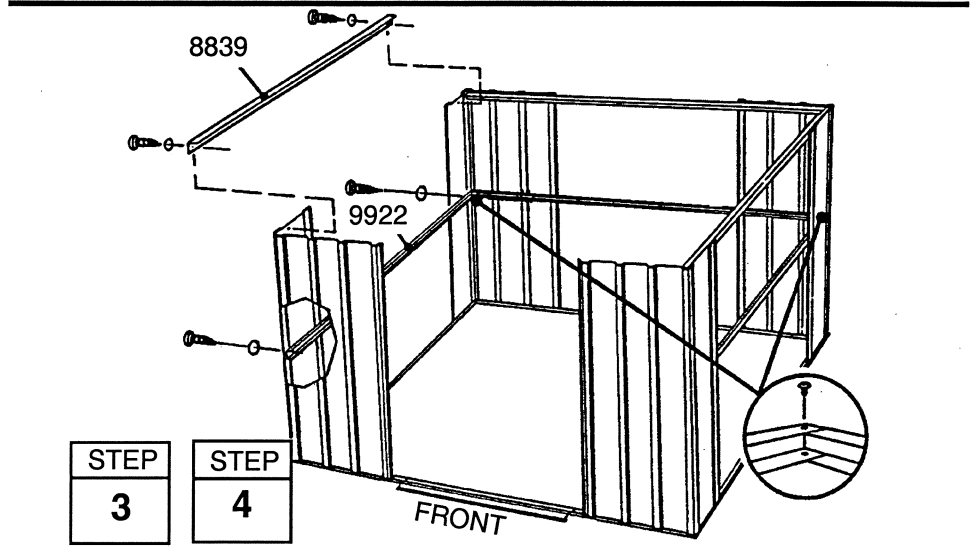
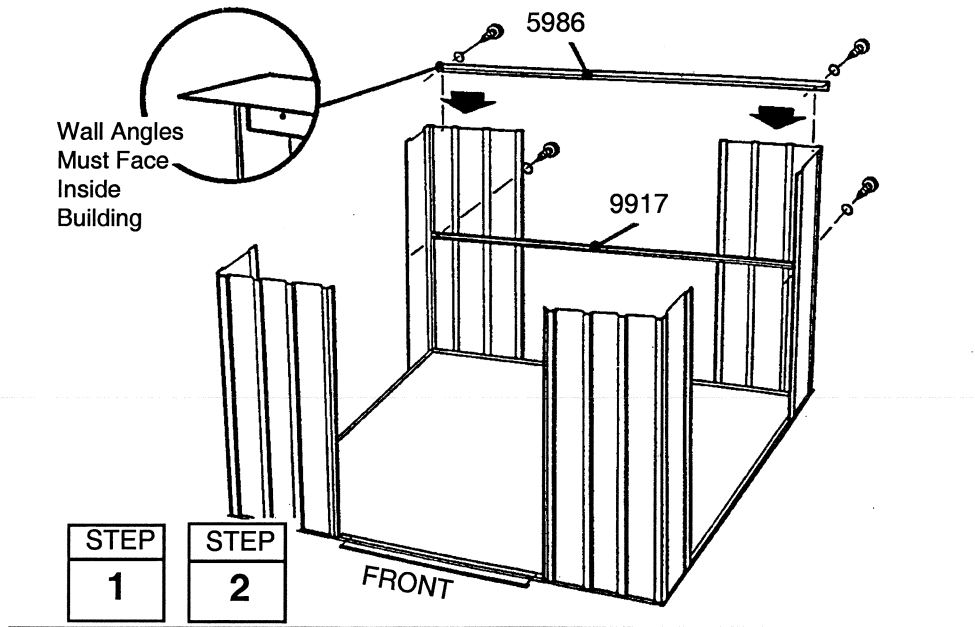

Step 8

V21 ctr

● Parts Needed For ● Wall Panels

- 8200 Wall Panel (4)
- 6627 Wall Panel (4)

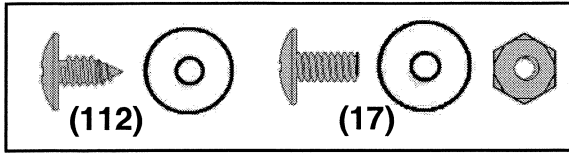

The wall panels come in two widths. Each wall panel has a crimped rib on one side. The crimped rib should go under the rib of the panel that follows it.

1 Locate all of the **wall panels** and set each one alongside the building.

2 Be sure that you have the correct panels in each position. Do this by overlapping the panels and determining if the holes line up with the holes in the frame.

3 Fasten the wall panels at the top and bottom with screws.

4 Fasten the center of each panel to the wall channel with screws. Fasten overlapping ribs as before.

5 When you have attached all wall panels in the correct positions, the building will look like this.

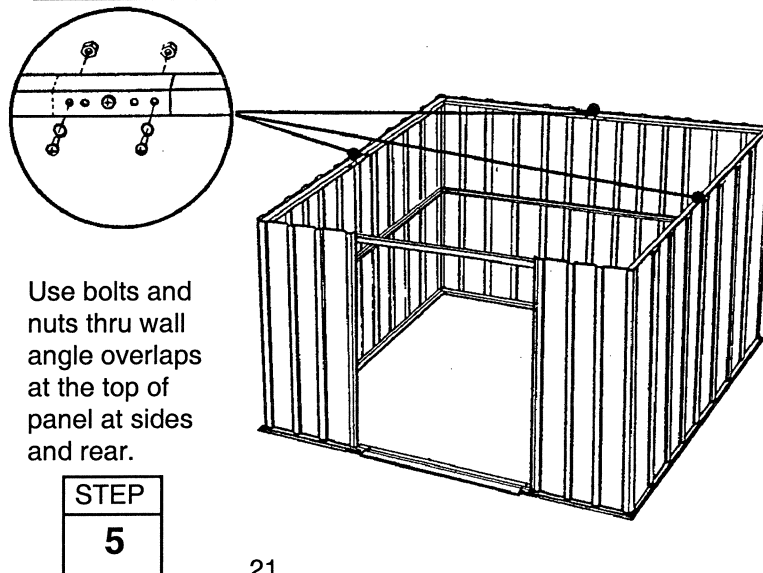
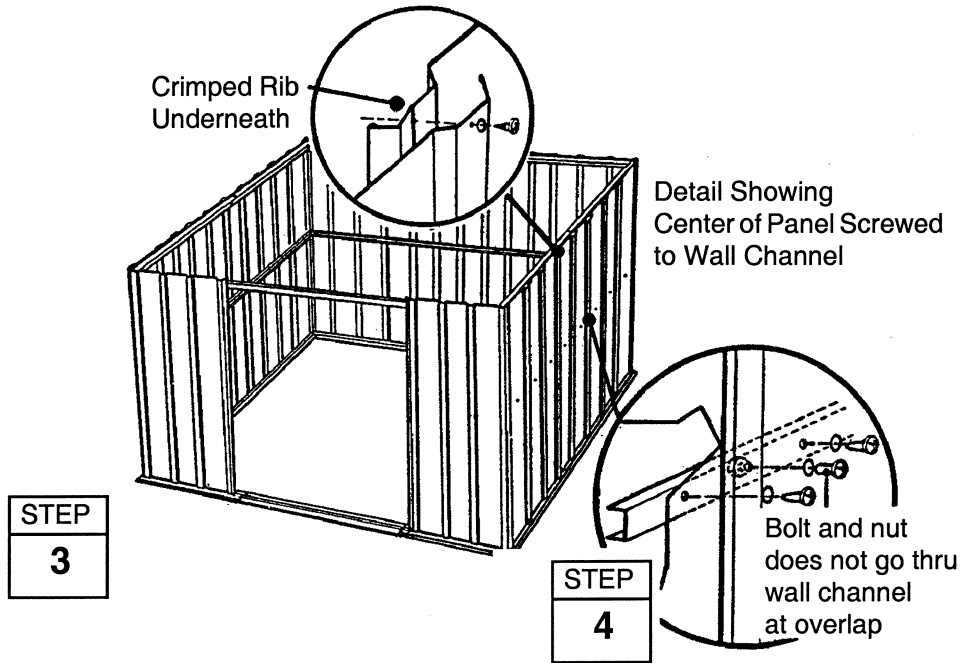
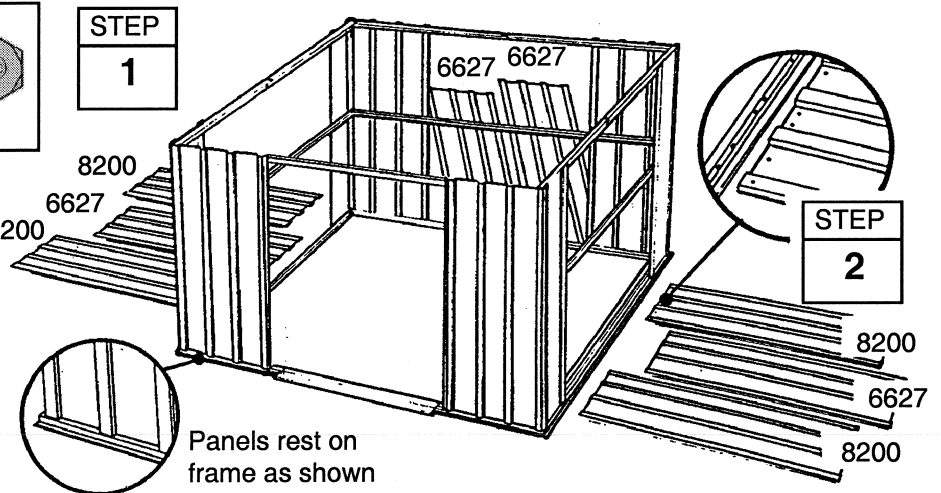

Step 9

U22 ctr

● Parts Needed For ● Front Channel/Door Jamb

- 9370 Door Jamb (2)
- 9365 Front Wall Channel (2)

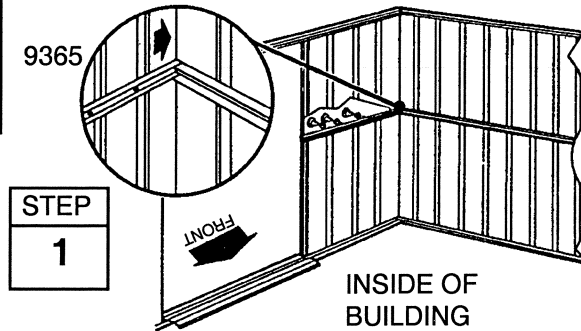
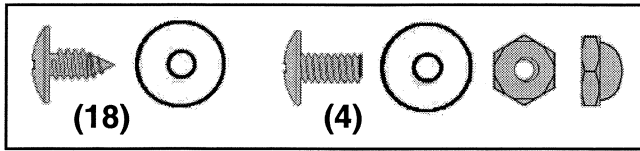

The door jambs reinforce the door opening and provide an attractive trim. Follow these steps for both door jambs.

1 Fasten the **front wall channels** in their positions between the end of the side wall channel and the corner panel using screws. Do not put a screw in the hole at the end behind the door opening at this time.

2 Fasten a **door jamb** to the front panel with two bolts, nuts and acorn nuts, as shown.

3 Fasten the center of the door jamb to the front wall panel and the front wall channel with two screws.

4 Fasten the top of the door jamb to the door track with two screws. Do the same for the bottom into frame.

Repeat steps 2 through 4 for the *opposite* door jamb.

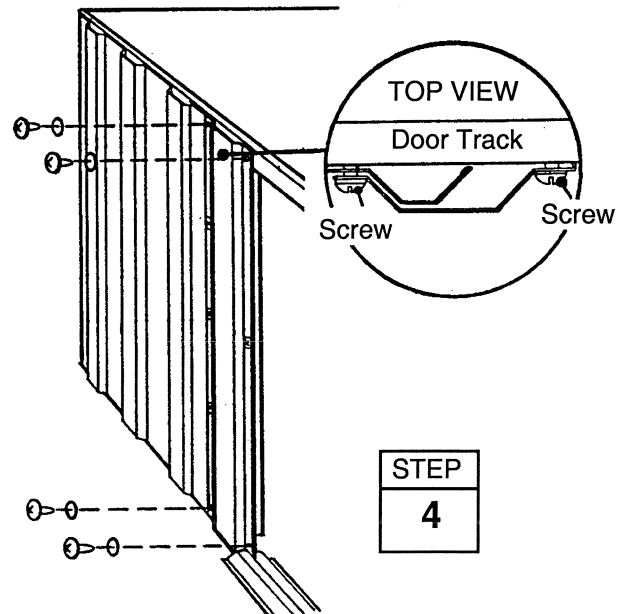
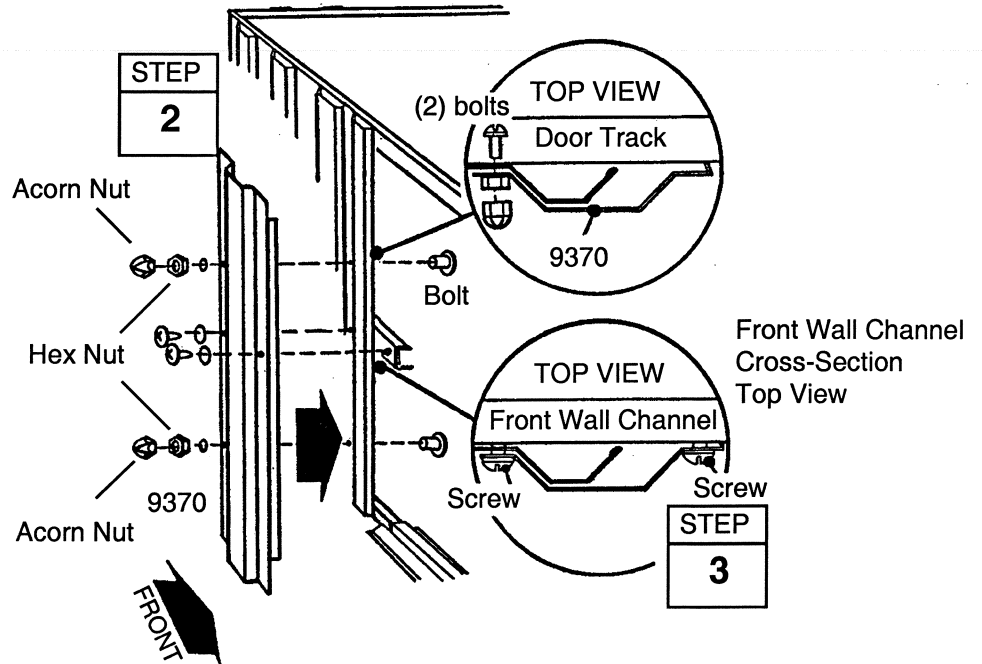

Step 10

A23et.ctr

● Parts Needed For ● Gable Assemblies

- 6000 Right Gable (2)
- 6001 Left Gable (2)
- 5971 Roof Beam Bracket (4)



The gables go on top of the front and rear walls to support the roof beams.

NOTE

The gables are packed nested together and might be mistaken as one piece. Carefully separate them before continuing.

1 Apply **edge trim** to the top edge of the **right gables** and **left gables**.

2 Attach the four **roof beam brackets** to the gables using two bolts, washers and nuts.

NOTE

Mounting leg of bracket must face toward center of gable and holes closest together must be on top



CAUTION:

To avoid mishap on the sharp edge the edge trim must remain in place on the top edge of the gable until right and left roof panels are in place.

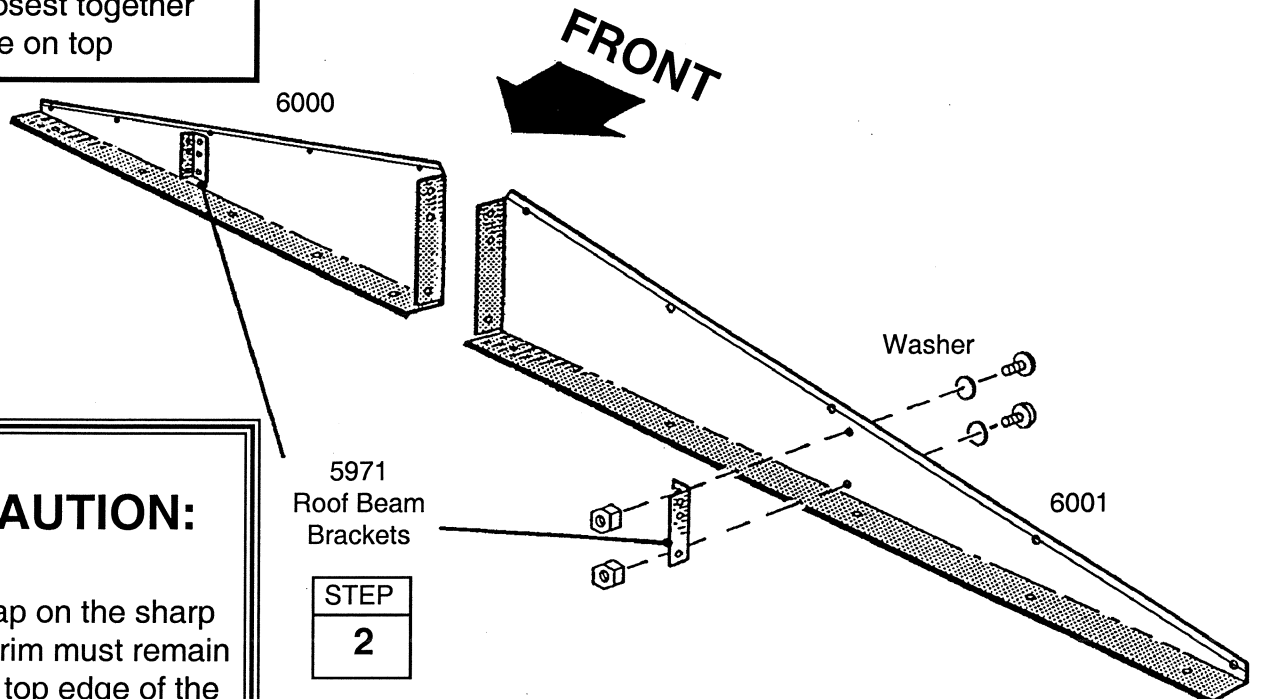
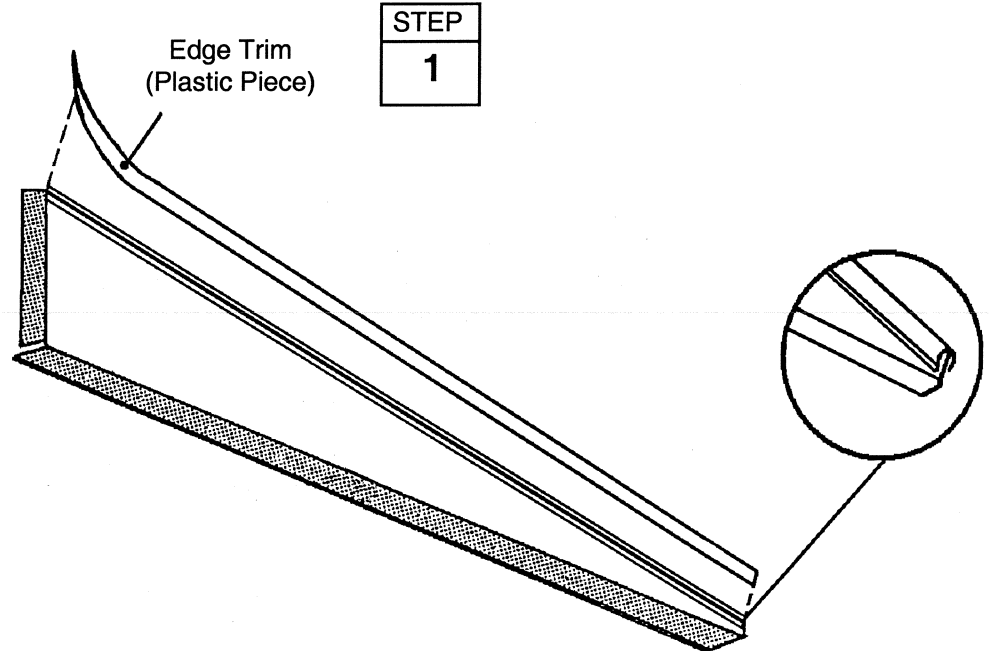

Step 11

A24 ctr

● Parts Needed For ● Gables/Braces

- Left Gable Assemblies (2)
- Right Gable Assemblies (2)
- 6635 Gable Brace (2)



(20)

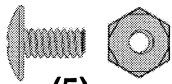

(5)

1 Lift and fasten a right and left gable, under angle at corner, to the door track and rear wall angle with screws.

Hint: On the rear gable, use a bolt and nut at the overlapping rear wall angle. On the front gable, leave out 2 screws closest to center gable leg.

2 Join the left and right gables together with a gable brace using a bolt and nut in the bottom hole *only*.

3 Repeat Steps 1 & 2 for the door track on the front of building, except for the **track supports**, fasten as shown.

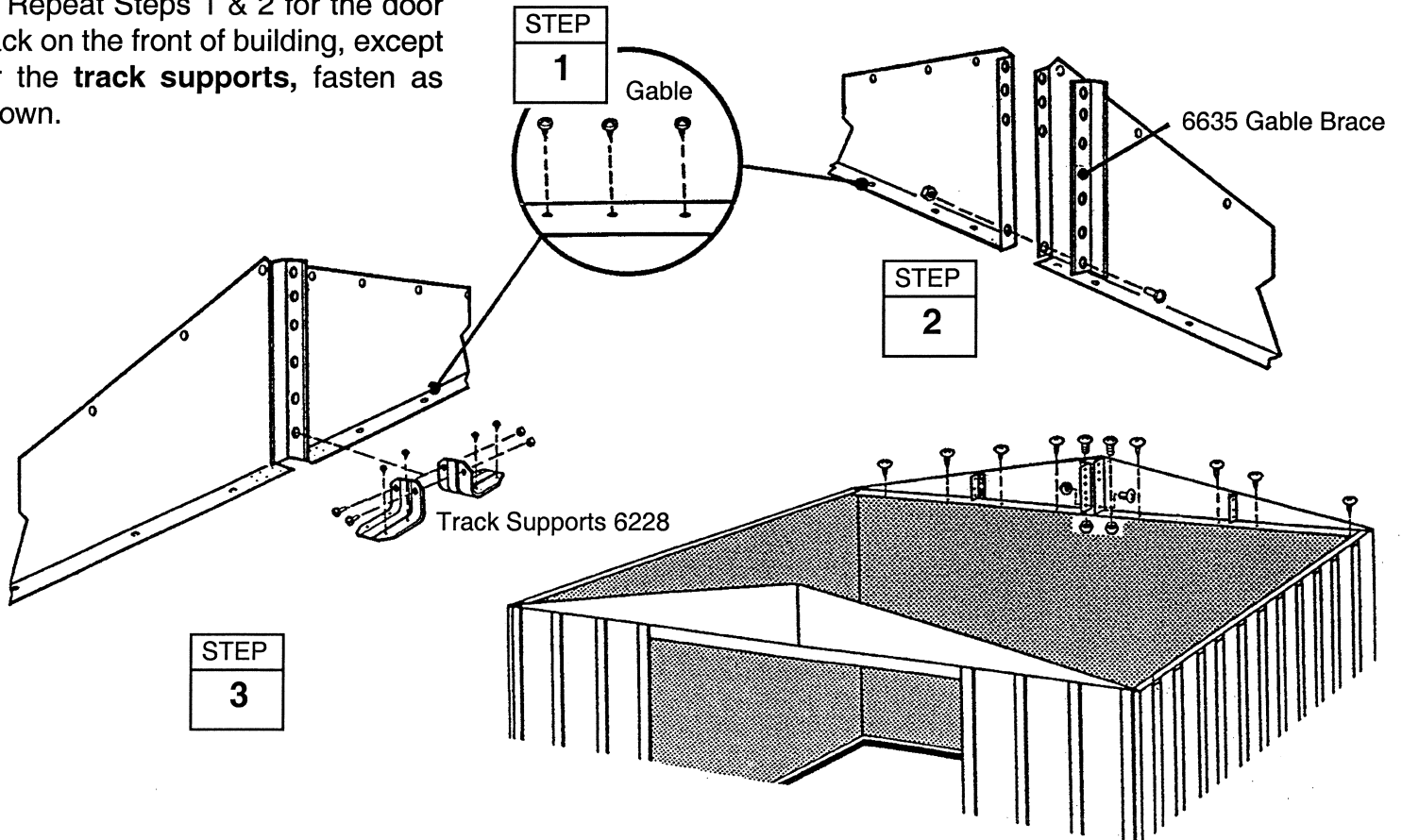
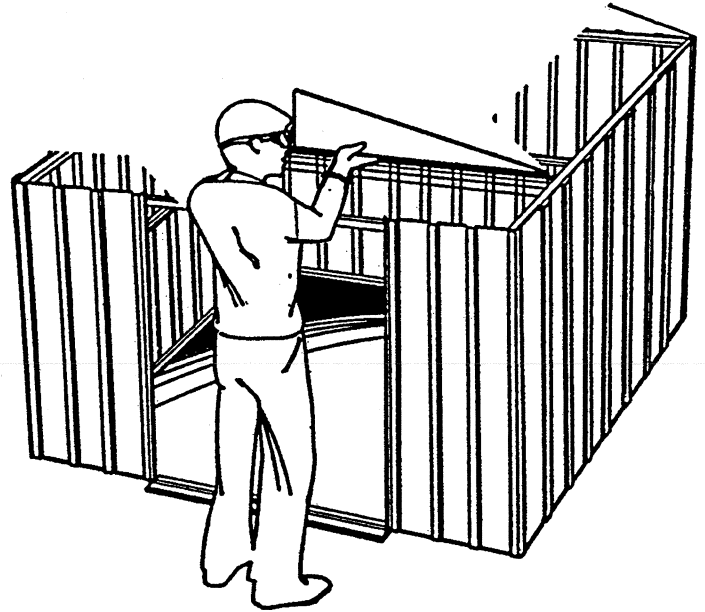

Step 12

A25 ctr

● Parts Needed For ● Roof Beams

- Main Roof Beam (1)
- Single Roof Beam (2)

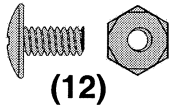

1 Spread the two halves of the **main roof beam** and fasten the roof beam to the gable brace of the front gable.

2 Fasten the other end of the main roof beam to the gable brace of the rear gable.

3 Fasten the **single roof beams**, *small holes on top*, as shown using bolts and nuts.

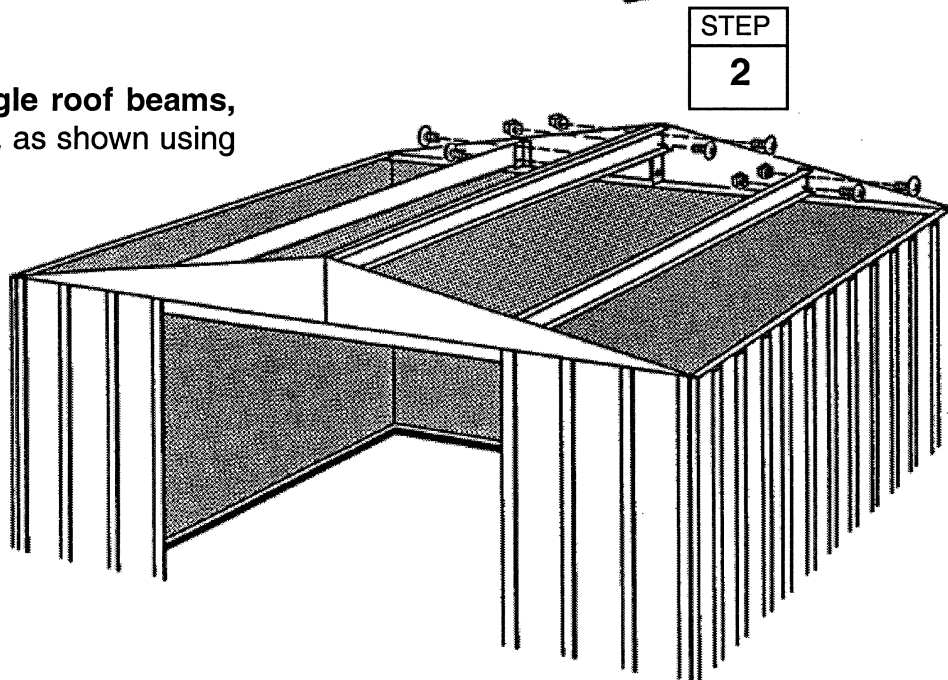
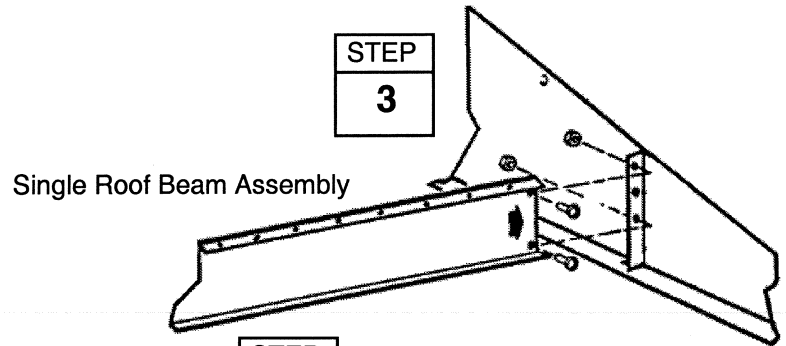

Spread Two Halves
Of Roof Beams

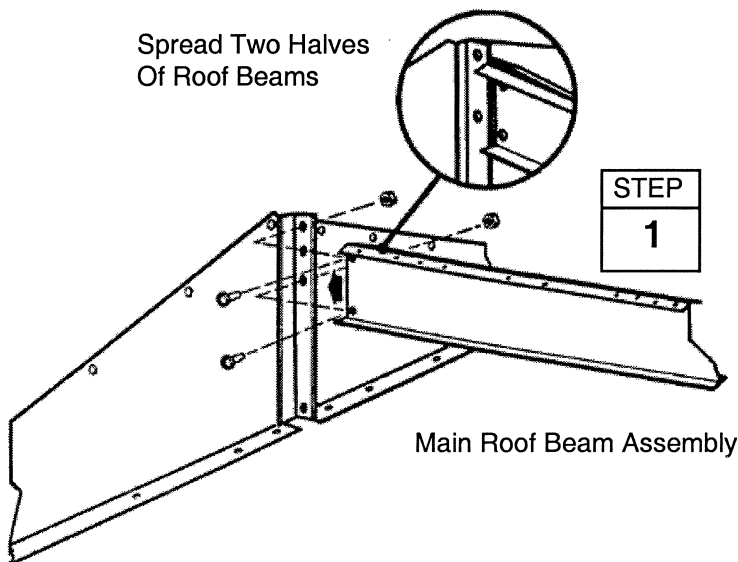

Step 13

A26et ctr

● Parts Needed For ● Right Roof Panel

● 8468 Right Roof Panel (1)

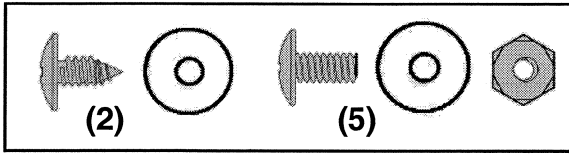

Installing the roof panels is best done with a step ladder. Begin installing roof panels at the back right corner of the building. Each screw and bolt in the roof requires a washer.

NOTE

Measure the building diagonally again and make adjustments to make sure the building is square. This will make the roof panels fit better, and holes will align.

NOTE

If a **Roof Beef-Up Kit** was purchased, assemble prior to attaching the roof panels.

1 Locate the roof panels by their numbers. *Note the sequence and position they are to be installed.*

2 Position a **right roof panel** at the back right corner and fasten to the top roof beam using a screw.

3 Remove edge trim from the left gable under the roof panel.

4 Continue fastening the right roof panel to the gable and lower roof beam using screws, bolts and nuts as shown. Do not fasten the lower end of the panels to the side wall angles at this time.

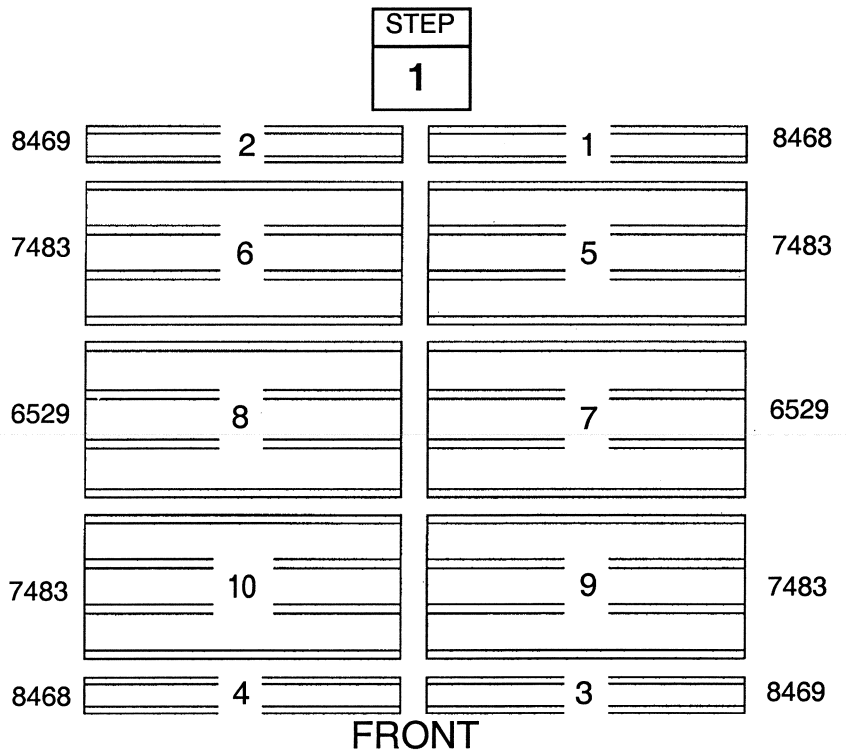

STEP	STEP	STEP
2	3	4

Hint: Follow the fastener sequence shown for proper alignment.

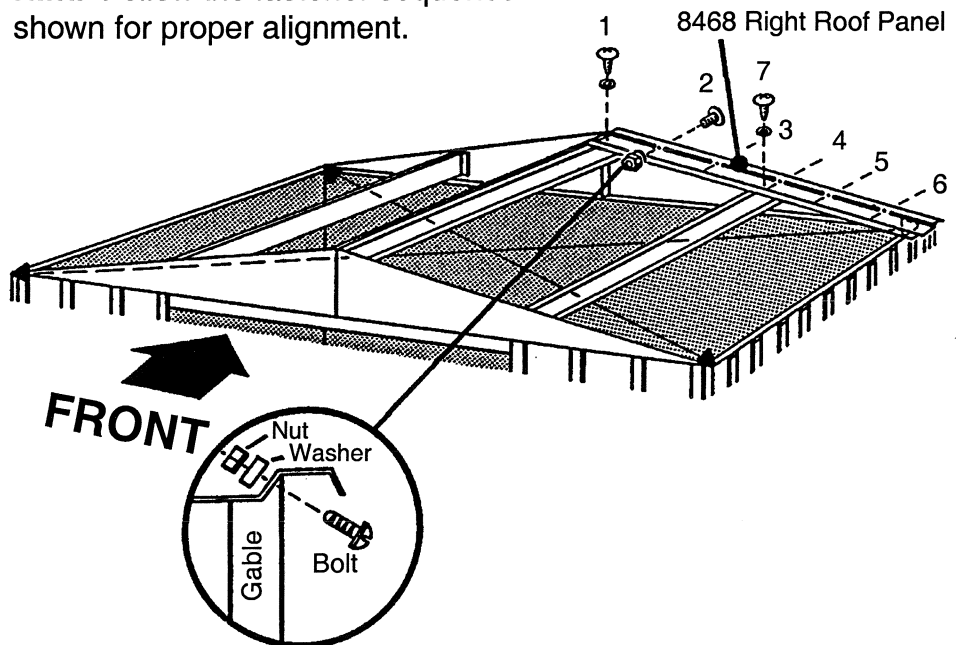

Step 14

A27 ctr

● Parts Needed For ● Roof Assembly

- 8468 Right Roof Panel (1)
- 8469 Left Roof Panel (2)
- 7483 Roof Panel (2)
- 6529 Roof Panel (2)

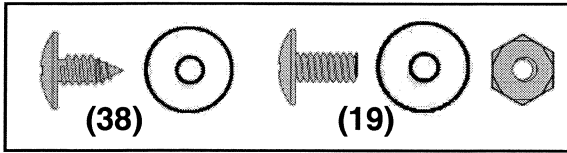

1 Install a **left roof panel** at the left rear and right front corner of the roof. Install a **right roof panel** at the left front corner of the roof.

2 Cut 4 short 2" (5,1 cm) strips off the roll of **weather stripping tape**, and put them aside. Cover the joint at the peak with weather stripping tape. Unroll the tape and press it down over the opening at the ridge as you install each roof panel. Do not cut the tape at this time.

3 Install 2 **narrow** and 2 **wide roof panels** in the sequence and positions shown on previous page. *Do not fasten the lower end of the panels to the side wall angles at this time.* Continue weather stripping the ridge opening.

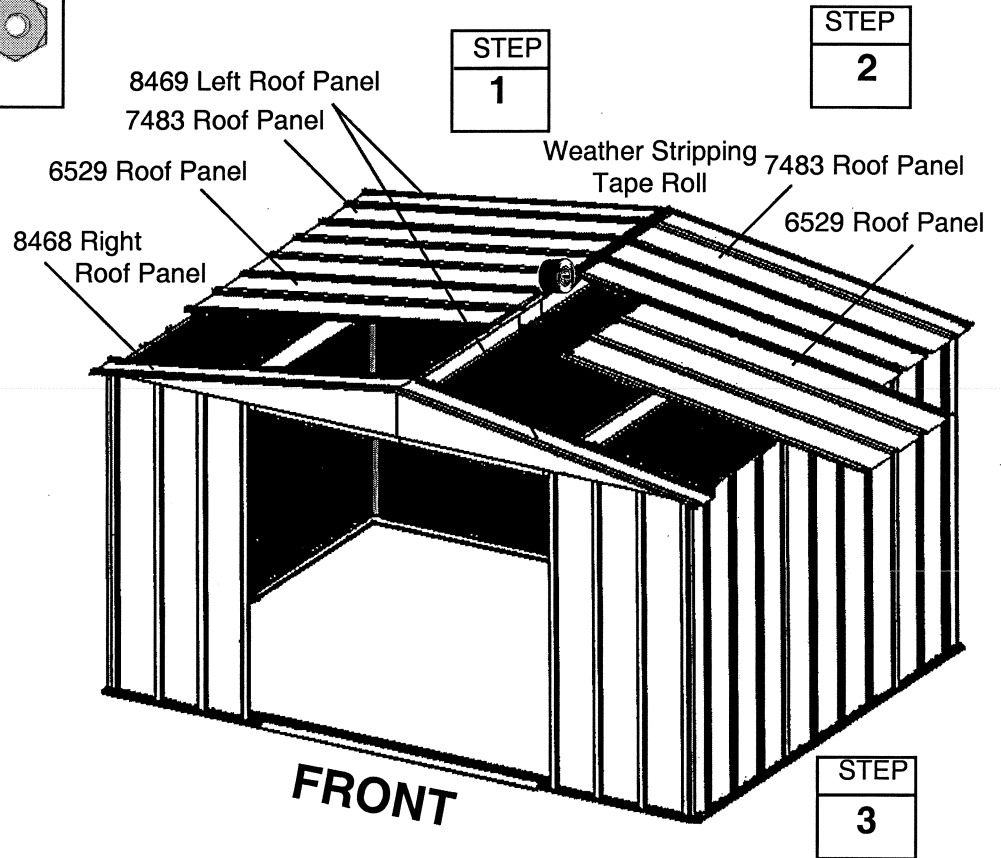

NOTE

Narrow roof panel crimped rib is overlapped by wide rib of adjacent panel where possible.

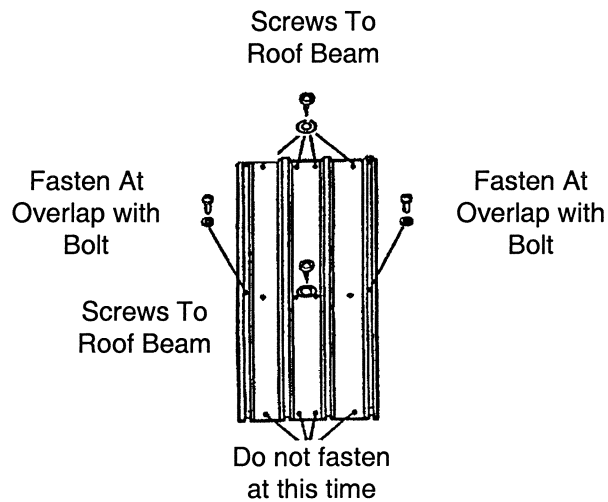

NOTE

If roof beam holes do not line up with the roof panel holes, shift the building from left to right. If this does not help, your building may not be level. Shim the corners until holes line up.

Step 15

A28 ctr

● Parts Needed For ● Ridge Caps & Panels

- 8840 Ridge Cap (1)
- 7483 Roof Panel (2)
- 8486 Ridge Cap (1)

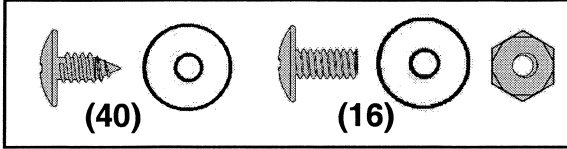

1 Install the first **ridge cap** on the completed roof section using bolts and nuts. Fasten roof panel overlaps not used for ridge cap. Cover the head of bolt with the 2" (5,1 cm) piece of weather stripping tape. Do not fasten the ends of the ridge cap at this time.

2 Install the second **ridge cap** overlapping the first ridge cap while installing the remaining narrow **roof panels**. Continue weather stripping the ridge.

3 Fasten the lower end of the panels to the side wall angles using screws and washers. Use bolts and nuts through wall angle overlaps at the bottom of the panel.

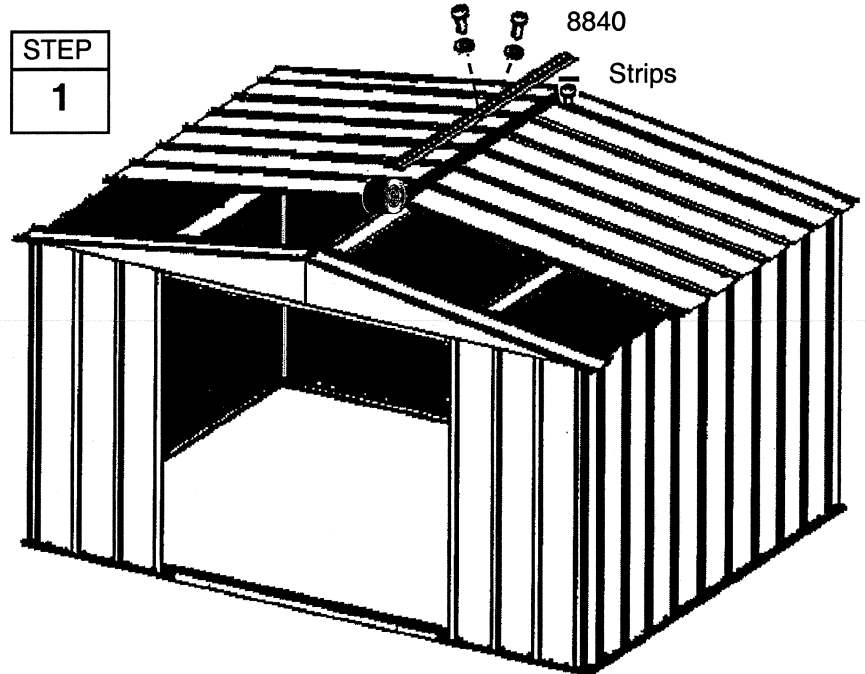

Cut Weather Stripping and Fold Under

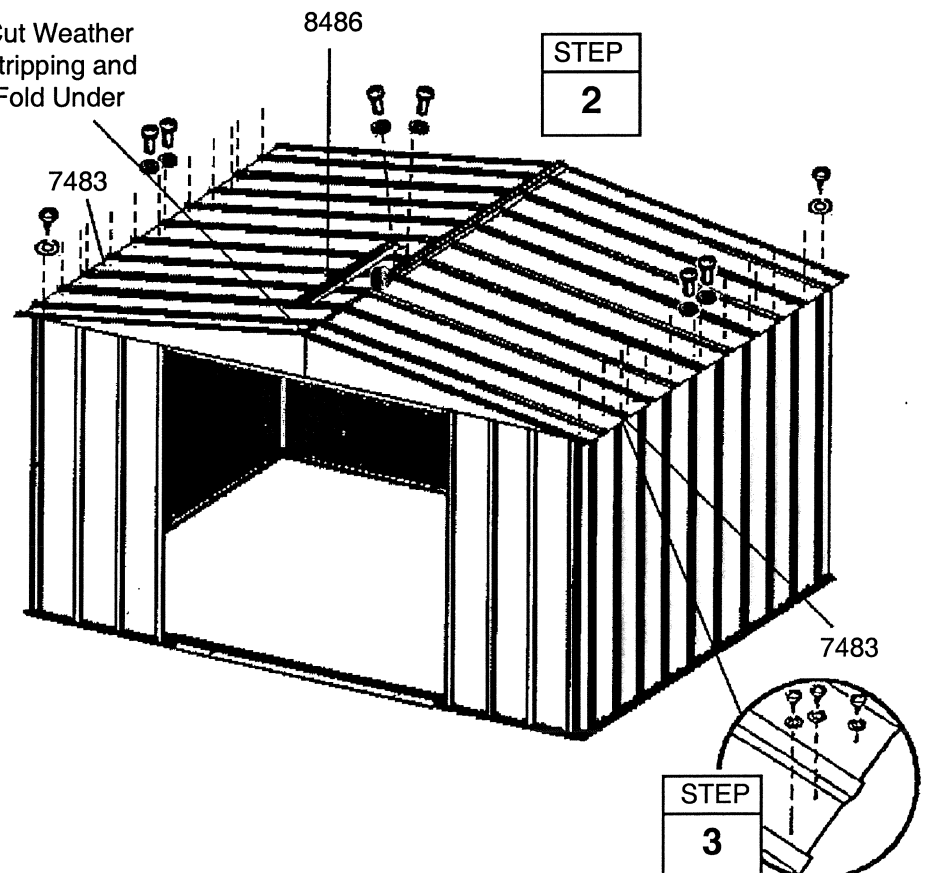

Step 16

A29ctr

● Parts Needed For ● Roof Trim

- 8485 Left Side Roof Trim (2)
- 8836 Right Side Roof Trim (2)

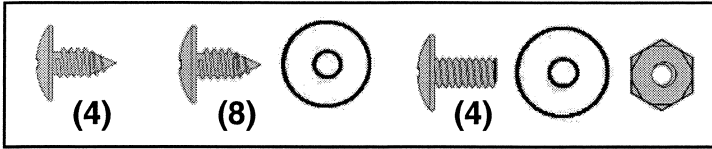

1 Attach the **right and left side roof trim** to the lower end of the roof panels on each side of the building using screws at each panel overlap.

NOTE

A single screw fastens both trim pieces at the overlap.

2 Using your thumb and index finger, overbend the bottom flange of the side roof trim at the corner inward enough so the right and left roof trim caps fit onto right and left corners.

3 Fasten the roof trim caps to the side trim using a screw.

4 Fasten the roof panel ribs, **peak caps** and ridge caps together using bolts and nuts.

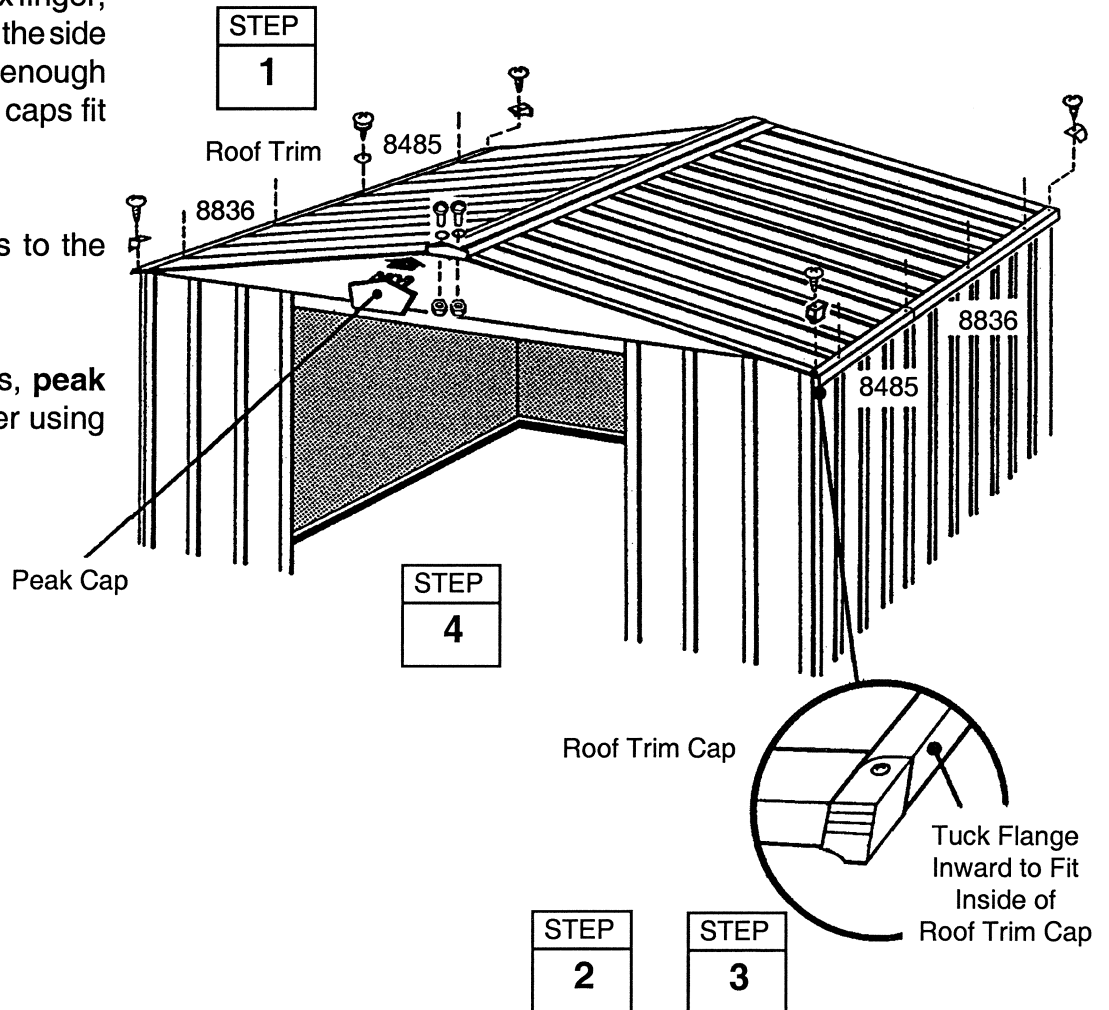

Step 17

U30 ctr

● Parts Needed For ● Door Assembly

- 3719 Door Handle Brace (2)
- 10477 Right and Left Doors (2)
- 10497 Horizontal Door Brace (4)
- 6300 Vertical Door Brace (2)

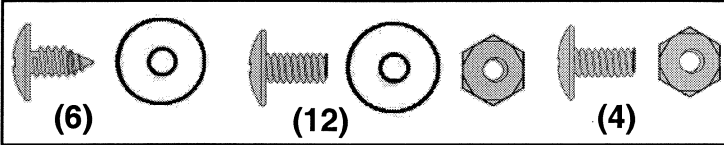

The steps on this page tell how to assemble the right door. You will perform exactly the same procedures for the left door. Each bolt and screw in the door requires a washer. Proceed as follows:

1 Attach the **door handle brace** and **handle** to the **door** with 1 bolt as shown. *Don't tighten the bolt yet.*

2 Swing the door handle brace up to the hole on the center of the door and insert a screw.

3 Hold the **vertical door brace** against the center of the inside surface of the door and turn the screw to hold the vertical door brace and door handle brace in place. Fasten to door above and below center connection using 2 screws.

4 Insert a second bolt in the door handle and tighten both bolts.

5 Put a **horizontal door brace** onto the top edge and bottom edge and fasten *with 1 bolt in the center.*

6 Attach the **lower door guides and bolts** as shown.

7 Repeat steps 1 through 6 for the **left door.**

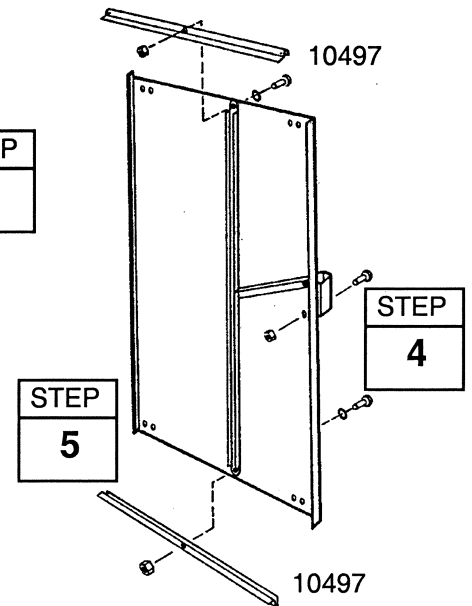
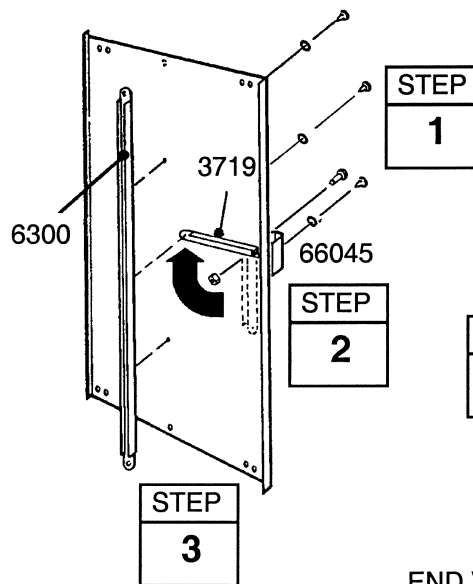
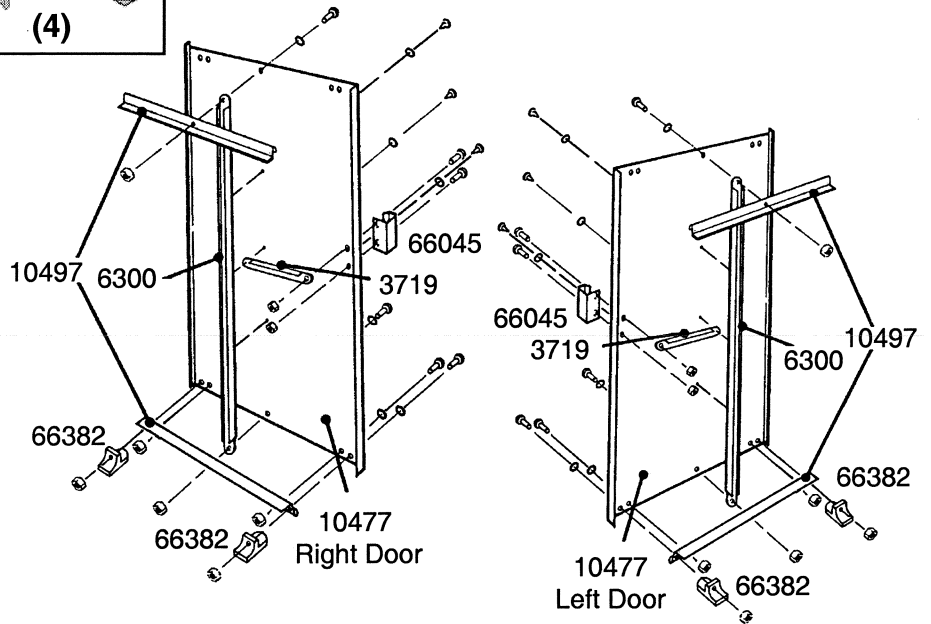

END VIEW
SHOWING:

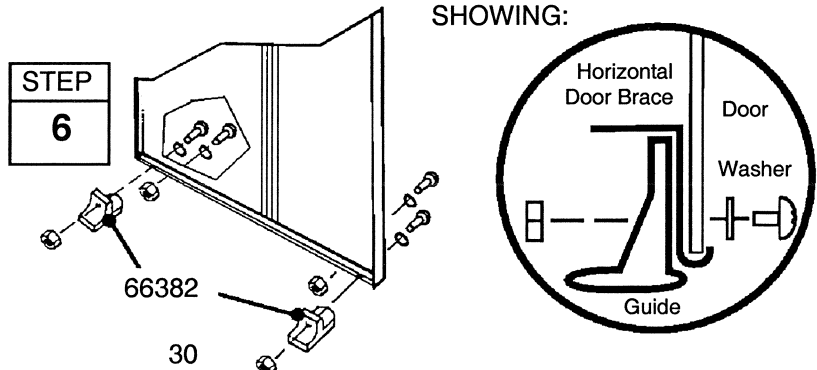

Step 18

A31ctr

● Parts Needed For ● Door Installation & Adjustment

- Right Door Assembly (1)
- Left Door Assembly (1)

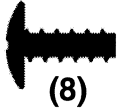

1 From inside the building, put the bottom of the right door assembly (on your left when you are inside the building) behind door jamb into the front frame track.

2 Position the top of the door so that the holes in the door line up with the holes in the door slides.

3 Fasten the door to the door slides using two #10Bx1/2" (13 mm) screws per door slide.

NOTE

The holes in the door slides allow you to adjust the doors. Place the door in the middle holes.

4 Repeat steps 1 through 3 for the left door.

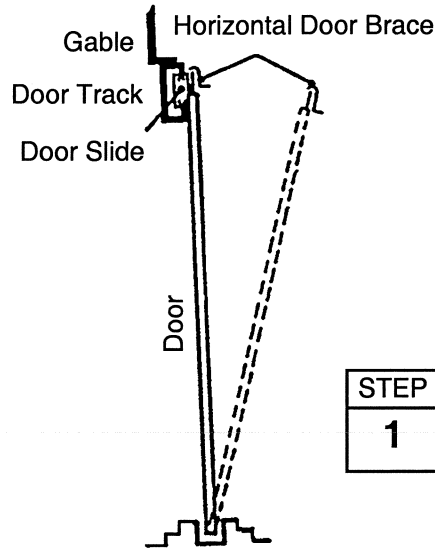

Front Floor Frame Assembly

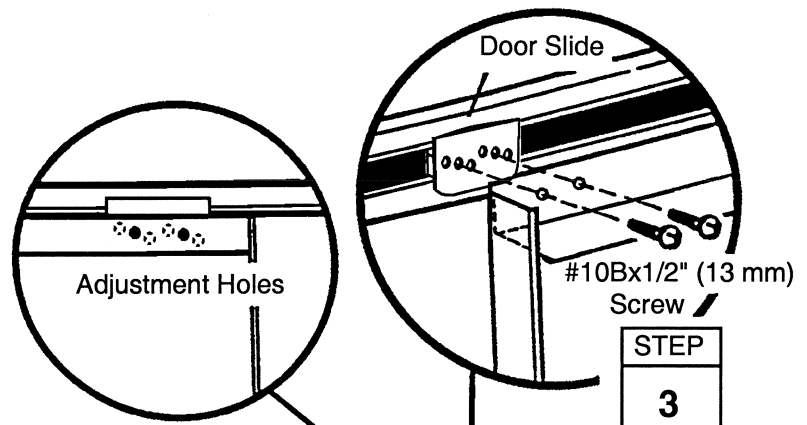

Adjustment Holes Allow Doors to Meet Evenly Along Their Length

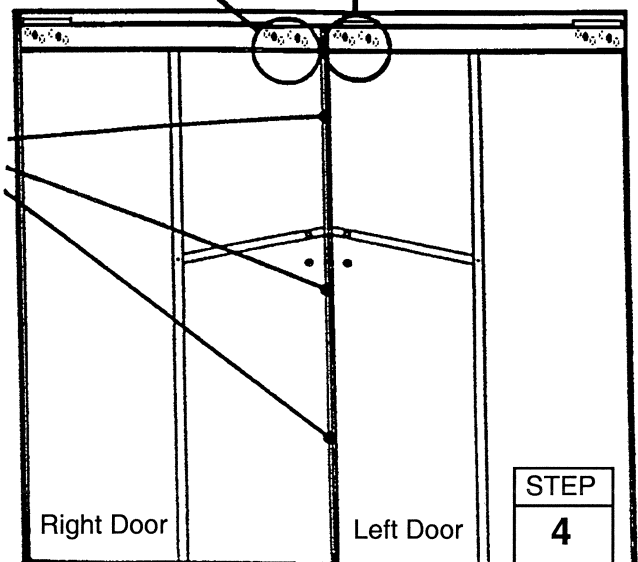

Keep this Owner's Manual and Assembly Instructions for future reference.

NP10867

V32et

Anchoring and Floor Frame

Anchoring

Anchor your building at this time.

Floor Frame

If you have purchased a Floor Frame Kit you need to install it at this time.

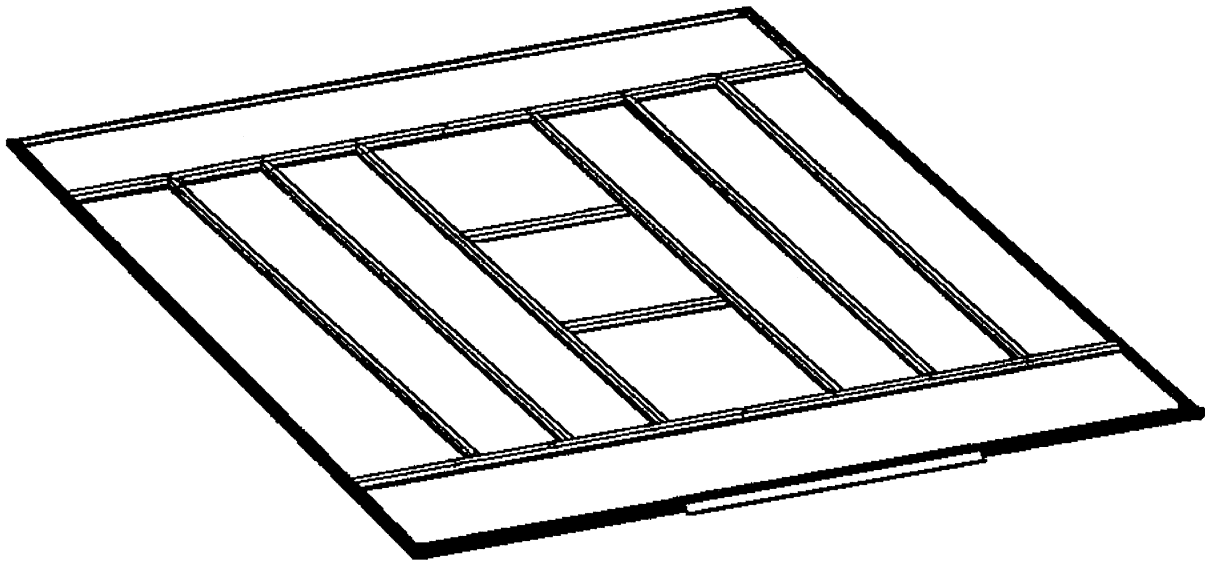

SOME FACTS ABOUT RUST

Rusting is a natural oxidizing process that occurs when bare metal is exposed to moisture. Problem areas include screw holes, unfinished edges, or where scrapes and nicks occur in the protective coating through normal assembly, handling and use. Identifying these natural rusting problem areas and taking some simple rust protection precautions can help to stop rust from developing, or stop it quickly as soon as it appears.

1. Avoid nicking or scraping the coating surface, inside and out.
2. Use all the washers supplied. In addition to protecting against weather infiltration, the washers protect the metal from being scraped by the screws.
3. Keep roof, base perimeter and door tracks free of debris and leaves which may accumulate and retain moisture. These can do double damage since they give off acid as they decay.
4. Touch up scrapes or nicks and any area of visible rust as soon as possible. Make sure the surface is free of moisture, oils, dirt or grime and then apply an even film of high quality touch-up paint.