

**TANK TO BOWL GASKET KIT**

**PART NUMBER:**  
7381426-100.0070A

- Includes 2 friction washers, 2 nuts & 2 gaskets
- Includes a nut tightening tool

**TO REPLACE TANK TO BOWL SEAL:**

- Turn off water supply; flush toilet (remove all water from the tank)
- Remove tank nuts (Do not remove 2nd set of tank nuts) **FIGURE 1 & 2**
- Remove tank from bowl, lay on flat surface on backside of tank to prevent scratching
- Grab and remove tank to bowl gaskets from the underside of the tank
- Take the included tool and remove the tank to bowl nut **counterclockwise**
- Remove friction washer

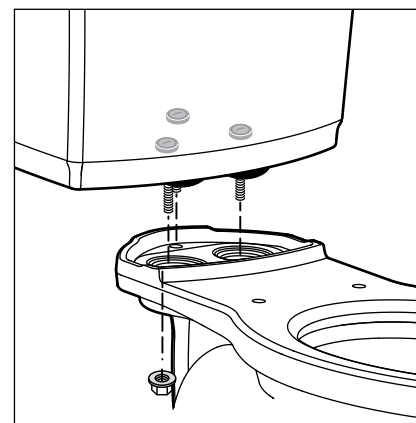

FIGURE 1

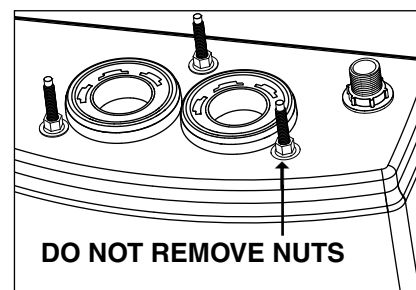

FIGURE 2

**TANK TO BOWL GASKET KIT**

**PART NUMBER:**  
7381426-100.0070A

**TO RE-INSTALL:**

- Hold the valve in the tank with one hand
- Place friction washer over threads on the bottom of the tank **FIGURE 3**
- Attach nut **FIGURE 4**
- Use supplied tool to tighten nuts to tank, **clockwise** (one hand tight)
- Apply and work the gaskets around the 6 retaining tabs on the nut so the inner rib on the gasket is captured between the tabs and the tank. Note the inner rib on the gasket is offset to one side. Be sure to orient the gasket with the inner rib towards the tank. When done correctly, the gasket should not be compressed and should be held in place while installing the tank
- Re-mount tank to bowl
- Replace refill tube to overflow
- Reattach refill tube clip onto the overflow tube of the new valve (hose should direct water into overflow tube)
- Insert the trip lever arm in to the yoke **FIGURE 5**
- Push the clevis pin through the arm **FIGURE 5**
- Insert the hair pin **FIGURE 5**

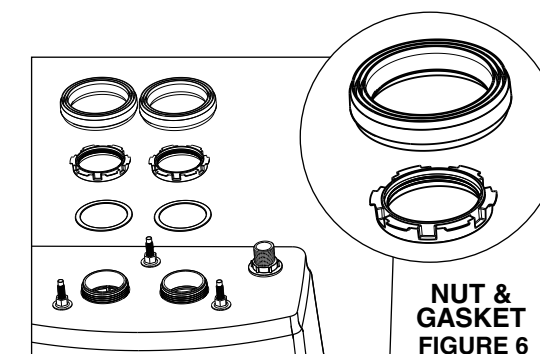

FIGURE 5

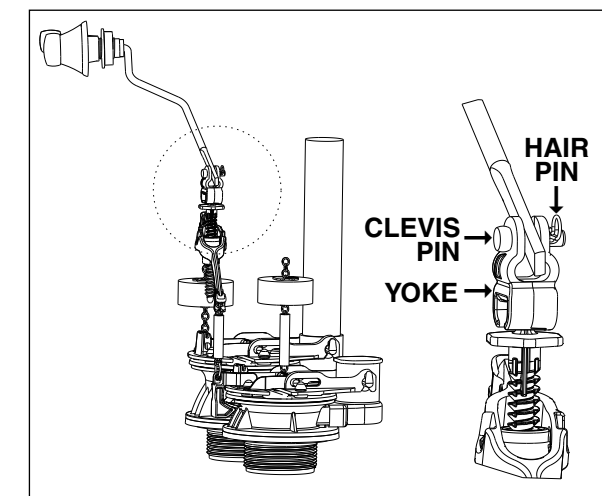

FIGURE 5



**TANK TO BOWL GASKET KIT**

**PART NUMBER:**  
7381426-100.0070A

**COMPLETE BY ADJUSTING THE SETTINGS:**

- Depress trip lever handle all the way **(A)**
- Adjust screw on the teeter bar **(B)** so rear frame **(C)** touches the frame stop **(D)**
- Return trip lever handle **(A)** to rest position.
- Make sure hook **(E)** is fully engaged under tab on valve body **(F)**, if not, slightly adjust screw to make sure hook is engaged.
- Turn water supply on; adjust water level to specified dimension on back of tank and flush 5 times to prime

