

2" 13-BALL NYLON GARAGE DOOR ROLLERS

Installation Instructions

1. Close door completely. Keep door closed by fastening "C" clamps on both the left and right door track against the top side of two rollers.
2. Disconnect power and lifting arm of garage door opener.
3. (FOR TOP ROLLERS GO TO STEP 4) Unbolt hinge from door. Feed roller into new hinge tube furthest from door. Place roller wheel into track and bolt hinge to door. Replace and tighten one hinge at a time before proceeding to the next step.
4. For Top Rollers only-install an additional "C" clamp in door track engaged in door so top section of door is restrained from rotating down when the bracket is removed. Replace brackets or rollers ONE AT A TIME, moving "C" clamp or locking pliers to prevent door section from pivoting. Install roller into bracket and feed roller into track. Fasten bracket to door and use adjusting bolt on bracket to snug door against jamb.

Tools Needed:

Vice grips



Wrench



C-Clamps

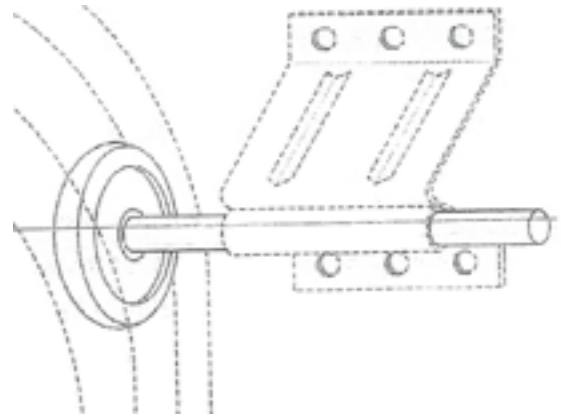

WARNING!

IMPROPER INSTALLATION OR DOOR POSITION CAN RESULT IN SERIOUS INJURY OR DEATH.

- Read and understand all instruction before you begin work.
- Wear safety goggles and gloves.
- Unplug power door opener and remove opener travel arm from door FIRST.
- Do not remove more than one part at a time.
- Do not attempt to raise or lower door without all components installed and securely tightened.
- Extension and torsion springs, along with attached hardware are under extreme tension at all times.
- All tension must be released from springs before any work is started.
- This hardware is intended for residential garage doors only.
- If you do not completely understand the installation instructions or are unsure whether the replacement part matches the part to be replaced, contact a professional installer.