

LA-2814E/S/F

# **USE AND CARE GUIDE**

**5 Light LED Bath Vanity**

**(METALLIC BRONZE)**

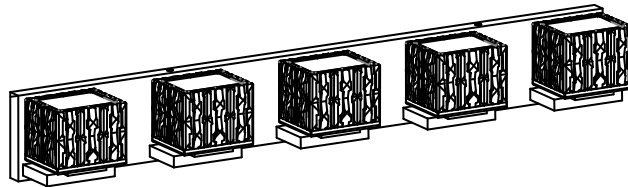

Questions, problems, missing parts? Before returning to the store,  
call Good Lumens Customer Service  
8 a.m. – 7 p.m., EST, Monday – Friday, 9 a.m. – 6 p.m., EST, Saturday

**800-527-0998**

---

**THANK YOU**

*We appreciate the trust and confidence you have placed in Good Lumens through the purchase of this fixture. We strive to continually create quality products designed to enhance your home. Visit us online to see our full line of products available for your home improvement needs. Thank you for choosing Good Lumens!*

# Table of Contents

Table of Contents .....	2	Assembly .....	6
Safety Information.....	2	Installation .....	7
Limited Warranty .....	2	Maintenance .....	9
Pre-installation .....	3	Care and Cleaning .....	9
Tools required for assembly & installation (not included) .....	3	Troubleshooting.....	9
Hardware Included .....	4	Service Parts .....	10
Package Contents .....	5		

# Safety Information

Before you begin, make sure you carefully read and understand the instructions in this manual. Please follow the instructions in the order presented in this manual and observe all warnings and cautions.

 **WARNING:** To reduce the risk of fire, consult a qualified electrician before installation.

 **WARNING:** Before beginning installation, turn off electricity at the circuit breaker box or the main fuse box.

 **WARNING:** Be careful not to damage or cut the wire insulation (covering) during fixture installation. Do not permit wires to contact any surface having a sharp edge. To do so may damage or cut the wire insulation, which could cause serious injury or death from electric shock.

 **CAUTION:** Consult a qualified electrician before installation.

 **WARNING:** If a dimmer control switch is used with this fixture, obtain professional advice to determine the correct type to use as well as the electrical rating required.

 **CAUTION:** All electrical connections must be in agreement with local codes, ordinances, or the National Electric Code (NEC). Contact your municipal building department to learn about your local codes, permits and/or inspections.

# Limited Warranty

## WHAT IS COVERED

The manufacturer warrants this lighting fixture to be free from defects in materials and workmanship for a period of five (5) years from date of purchase. This warranty applies only to the original consumer purchaser and only to products used in normal use and service. If this product is found to be defective, the manufacturer's only obligation, and your exclusive remedy, is the repair or replacement of the product at the manufacturer's discretion, provided that the product has not been damaged through misuse, abuse, accident, modifications, alterations, neglect or mishandling. This warranty shall not apply to any product that is found to have been improperly installed, set-up, or used in any way not in accordance with the instructions supplied with the product. This warranty shall not apply to a failure of the product as a result of an accident, misuse, abuse, negligence, alteration, or faulty installation, or any other failure not relating to faulty material or workmanship. This warranty shall not apply to the finish on any portion of the product, such as surface and/or weathering, as this is considered normal wear and tear.

## WHAT IS NOT COVERED

The manufacturer does not warrant and specially disclaims any warranty, whether express or implied, of fitness for a particular purpose, other than the warranty contained herein. The manufacturer specifically disclaims any liability and shall not be liable for any consequential or incidental loss or damage, including but not limited to any labor / expense costs involved in the replacement or repair of said product.

Contact the Customer Service Team at (800)527-0998.

# Pre-installation

## TOOLS REQUIRED FOR ASSEMBLY & INSTALLATION (NOT INCLUDED)

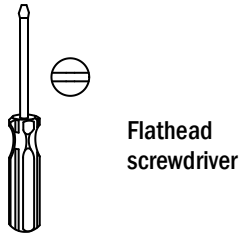
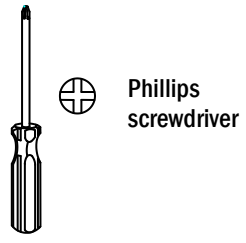

# Pre-installation (continued)

## HARDWARE INCLUDED



NOTE: Hardware not shown to actual size.

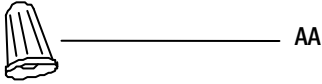

AA

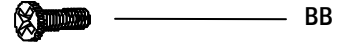

BB

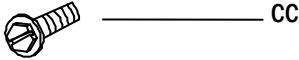

CC

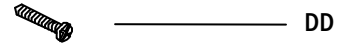

DD

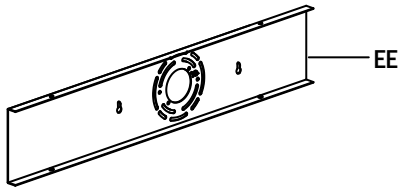

EE

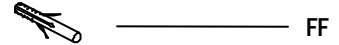

FF

Part	Description	Quantity
AA	Wire connectors	3
BB	Outlet box screws	2
CC	Ground screw	1
DD	Wood screws	2
EE	Mounting plate	1
FF	Plastic anchors	2

# Pre-installation (continued)

## PACKAGE CONTENTS

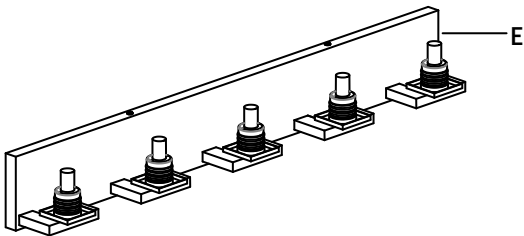
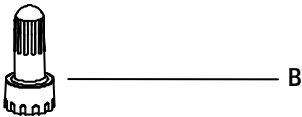
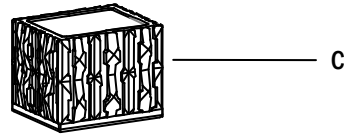
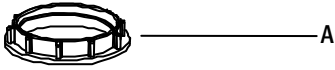

Part	Description	Quantity
A	Screw shells	5
B	Spanner	1
C	Glass shades	5
D	Screws	4
E	Fixture body	1

# Assembly

## 1 Attaching the glass shade

- Carefully unpack your new fixture and lay out all the parts on a clear area. Take care not to lose any small parts necessary for installation.
- Remove the screw shell (A) from the fixture.
- Place the glass shades (C) over the socket of the fixture body (E), fasten with screw shells (A) using the included spanner (B).

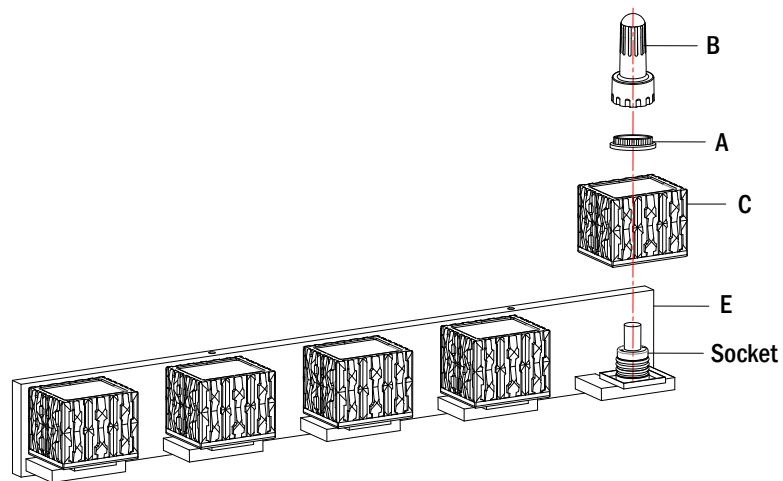

# Installation

## 1 Removing the mounting plate

- Prior to installation, remove the mounting plate (EE) by removing the screws (D) from the fixture body (E).

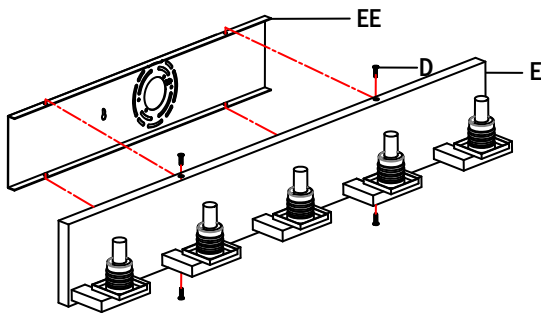

## 2 Position the mounting plate

- Position mounting plate (EE) on the wall, and mark location of two mounting holes.
- Drill the holes on the wall, insert the plastic anchors (FF) into the wall.

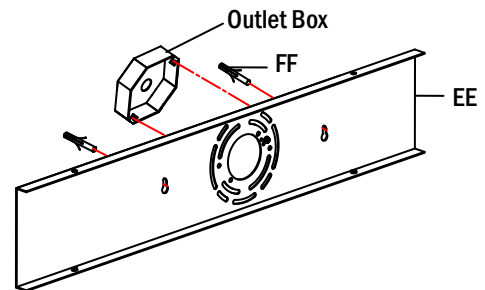

## 3 Install the mounting plate

- Attach the mounting plate (EE) to the outlet box using the outlet box screws (BB) and the wood screws (DD). The side of the mounting plate marked "GND" must face out.

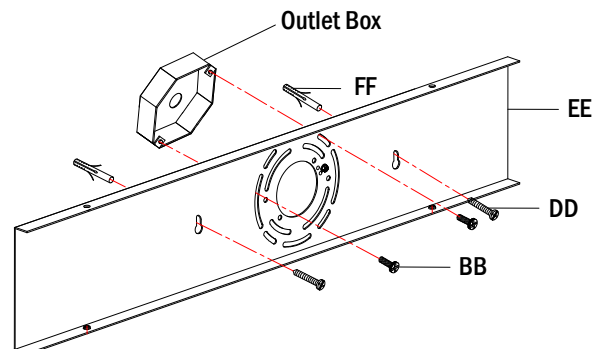

# Installation(continued)

## 4 Connecting the wires

- Connect the white wire from the fixture to the white wire from the outlet box, and the black wire from the fixture to the black wire from the outlet box. Cover the two wire connections using the two provided wire connectors (AA). Wrap the two wire connections with electrical tape for a more secure connection. If your outlet box has a ground wire (green or bare copper), connect fixture's ground wire to it using the wire connectors (AA). Otherwise connect the copper ground from the fixture to ground screw (CC) on the mounting plate (EE). Note: If you have electrical questions, consult your local electrical code for approved grounding method.

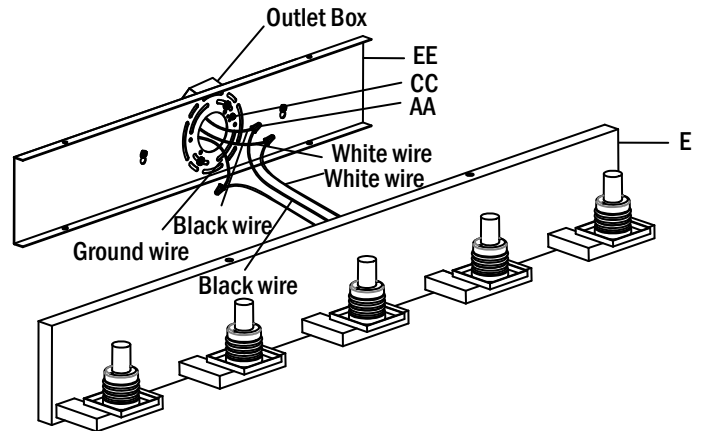

## 5 Place fixture body to mounting plate

- Place fixture body (E) over mounting plate (EE) and secure with screws (D).
- Installation is complete. Turn on the power at the circuit breaker or fuse box. Turn the light switch on to activate the fixture.

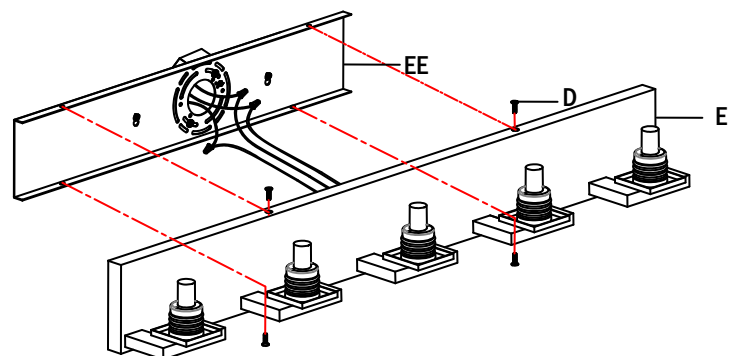



## Maintenance

- Shut off the main power supply before performing any maintenance on the light.
- Wipe with damp cloth or use window cleaner. Do not use abrasives.

## Care and Cleaning

- To clean the outside of the fixture, use a dry or slightly dampened clean cloth (use clean water, never a solvent) to wipe the glass and surface of the fixture.
- To clean the inside of the fixture, first disconnect power to the fixture by turning off the circuit breaker or by removing the fuse at the fuse box. Next, use a dry or slightly dampened clean cloth (use clean water, never a solvent) to wipe the inside glass and interior surface of the fixture.
- Do not use any cleaners with chemicals, solvents or harsh abrasives. Use only a dry soft cloth to dust or wipe carefully

## Troubleshooting

Problem	Possible Cause	Corrective Action
The bulb will not light.	The power is off.	Make sure power supply is on.
	There is a faulty wire connection.	Check the wiring.
	There is a faulty switch.	Test or replace the switch.
The fuse blows or circuit breaker trips when the light is turned on.	There are crossed wires or the power wire is grounding out.	Check the wire connections.

# Service Parts

## MODEL TYPE



AA



BB



CC



DD

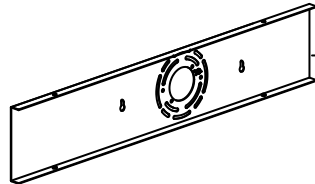

EE



FF



A



B

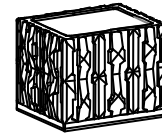

C



D

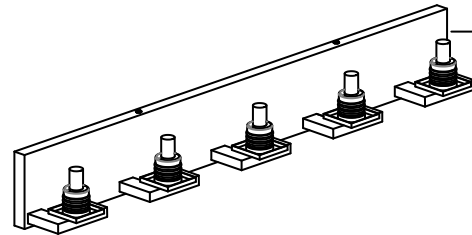

E

Part	Description	Quantity
AA	Wire connectors	3
BB	Outlet box screws	2
CC	Ground screw	1
DD	Wood screws	2
EE	Mounting plate	1
FF	Plastic anchors	2

Part	Description	Quantity
A	Screw shells	5
B	Spanner	1
C	Glass shades	5
D	Screws	4
E	Fixture body	1



Questions, problems, missing parts? Before returning to the store,  
call Good Lumens Customer Service  
8 a.m. - 7 p.m., EST, Monday - Friday, 9 a.m. - 6 p.m., EST, Saturday

**800-527-0998**

Retain this manual for future use.

LA-2814E/S/F

# GUÍA DE USO Y CUIDADOS

## 5 VANIDAD DE BAÑO DE LUZ LED (BRONCE METÁLICO)

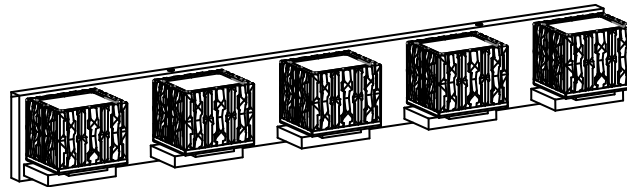

reguntas, problemas, partes faltantes ? Antes de regresar a la tienda,  
Llamar al servicio de atención al cliente de Good Lumens servicio al cliente  
8 a.m. - 7 p.m., EST, de lunes a viernes, 9 a.m. - 6 p.m., EST, el sábado

**800-527-0998**

---

### **RACIAS**

*Apreciamos la confianza que usted ha puesto en la bahía de Hampton con la compra de este accesorio ligero. Nos esforzamos para crear continuamente productos de calidad diseñados para mejorar su hogar. Visítenos en línea para ver nuestra línea completa de productos disponibles para sus necesidades de mejoras para el hogar. ¡Gracias por elegir Good Lumens!*

# Tabla De Contenido

Tabla De Contenido .....	2
Información De Seguridad .....	2
Garantía limitada .....	2
Pre-instalación.....	3
HERRAMIENTAS NECESARIAS PARA EL MONTAJE Y LA	
INSTALACIÓN (NO INCLUIDOS) .....	3
PIEZAS INCLUIDAS PARA LA INSTALACIÓN .....	4

CONTENIDO DEL PAQUETE.....	5
Asamblea .....	6
Instalación .....	7
Mantenimiento.....	9
Cuidado y limpieza .....	9
Solución de problemas .....	9
Partes de servicio .....	10

## Información De Seguridad

Antes de comenzar, asegúrese de leer detenidamente y comprender las instrucciones de este manual. Siga las instrucciones en el orden que se presenta en este manual y observe todas las advertencias y precauciones.



**ADVERTENCIA:** Para reducir el riesgo de incendio, consulte a un electricista calificado antes de la instalación.



**ADVERTENCIA:** Antes de comenzar la instalación, desconecte el interruptor de circuito o la caja de fusibles principal



**ADVERTENCIA:** Tenga cuidado de no dañar o cortar el aislamiento del conductor (cubierta) durante la instalación de la lámpara. No permita que los cables entren en contacto con superficies que tengan un borde con filo, ya que esto podría dañar o cortar el aislamiento del conductor y ocasionar lesiones graves o la muerte debido a una descarga eléctrica.



**PRECAUCIÓN:** Consulte a un electricista calificado antes de instalar.



**ADVERTENCIA:** Si se utiliza un regulador de control de intensidad con esta lámpara, solicite asesoría profesional para determinar el tipo y la clasificación eléctrica correcta que se requiere.



**PRECAUCIÓN:** Todas las conexiones eléctricas deben cumplir con los códigos locales, las ordenanzas o el Código Nacional de Electricidad (NEC, por sus siglas en inglés). Póngase en contacto con su Departamento de construcción municipal para consultar sobre sus códigos, permisos y/o inspecciones locales.

## Garantía limitada

### QUE ESTA CUBIERTO

El fabricante garantiza que este accesorio de iluminación a estar libre de defectos en materiales y mano de obra durante un período de cinco (5) años a partir de la fecha de compra. Esta garantía se aplica sólo al comprador original y sólo a los productos utilizados en condiciones normales de uso y servicio. Si se encuentra que este producto está defectuoso, la única obligación del fabricante, y su solución exclusiva, es la reparación o sustitución del producto, a discreción del fabricante, siempre que el producto no ha sido dañado por el mal uso, abuso, accidentes, modificaciones, alteraciones, negligencia o mal manejo. Esta garantía no se aplicará a cualquier producto que se demuestre que ha sido instalado incorrectamente, puesta a punto, o utilizado en cualquier manera no conforme con las instrucciones suministradas con el producto. Esta garantía no se aplicará a una falla del producto como consecuencia de un accidente, mal uso, abuso, negligencia, alteración o instalación defectuosa, o cualquier otro fallo que no se refieran a los materiales o ejecución defectuosa. Esta garantía no se aplicará a la meta en cualquier parte del producto, tales como la superficie y / o la intemperie, ya que se considera uso y desgaste normal.

### LO QUE NO ESTÁ CUBIERTO

El fabricante no garantiza y especialmente niega cualquier garantía, expresa o implícita, de aptitud para un propósito particular, excepto la garantía contenida en este documento. El fabricante rechaza específicamente cualquier responsabilidad y no será responsable por cualquier pérdida consecuente o incidental o daños, incluyendo pero no limitado a cualquier mano de obra Gastos de gastos que implica la sustitución o reparación de dicho producto.

Comuníquese con el Equipo de Servicio al Cliente al (800)527-0998.

# Pre-instalación

## HERRAMIENTAS NECESARIAS PARA EL MONTAJE Y LA INSTALACIÓN (NO INCLUIDOS)



Gafas De Seguridad



Destornillador De CabezaPhillips



AlicatesDe Cadena



Escalera

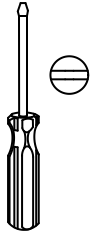

DestornilladorDe CabezaPlana

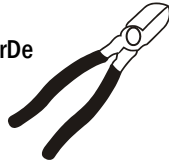

Cortaalam bres



Cita Aislante

# Pre-instalación (continuado)

## PIEZAS INCLUIDAS PARA LA INSTALACIÓN



**NOTA:** Piezas no están mostradas al tamaño real.

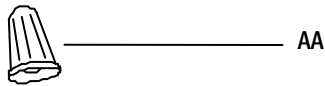

AA



BB

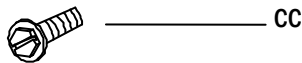

CC

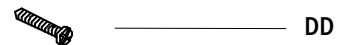

DD

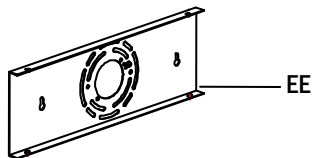

EE

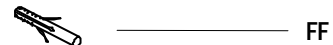

FF

Parte	Descripción	Cantidad
AA	Conectores de cable de	3
BB	A cabo tornillos cuadro	2
CC	Tornillos de rosca de tierra	1
DD	Tornillo para madera	2
EE	Placa de montaje	1
FF	Ancla de plástico	2

# Pre-instalación (continuado)

## CONTENIDO DEL PAQUETE

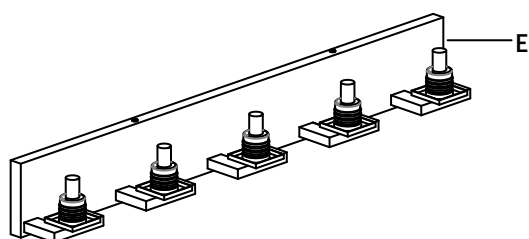
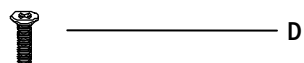
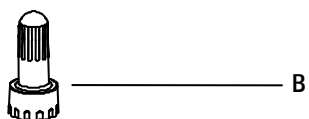
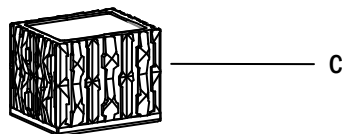
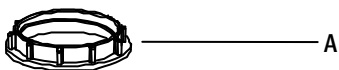

Parte	Descripción	Cantidad
A	Tornillo de shell	5
B	Llave inglesa	1
C	Vidrio	5
D	Tornillo	4
E	Cuerpo del aparato	1



## 1 Colocación de la cortina de vidrio

- Desempaque cuidadosamente su nueva lámpara y coloque todas las partes en una superficie despejada. Tenga cuidado de no perder las partes pequeñas que son necesarias para la instalación.
- Retire la cubierta del tornillo (A) del accesorio.
- Coloque los cristales (C) sobre el zócalo del cuerpo del aparato (E), asegure con las cáscaras del tornillo (A) usando la llave incluida (B).

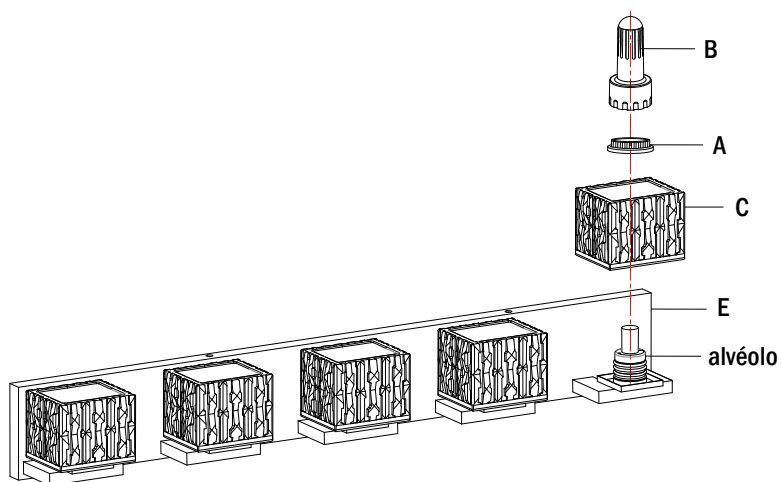

# Instalación

## 1 Extracción de la placa de montaje

- Antes de la instalación, retire la placa de montaje (EE) retirando los tornillos (D) del cuerpo de fijación (E).

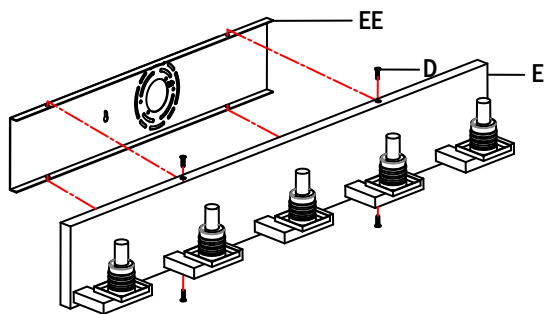

## 2 Coloque la placa de montaje

- Posición de montaje mural (EE) en la pared, y marca la ubicación de los dos orificios de montaje.
- Haga los agujeros en la pared, inserte el ancla de plástico (FF) en la pared.

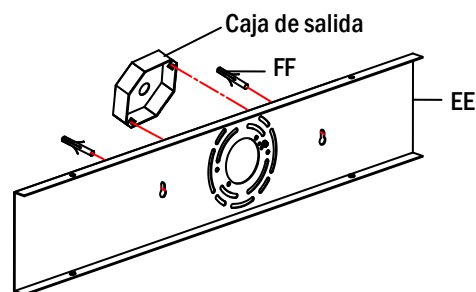

## 3 Instale la placa de montaje

- Fije la placa de soporte (EE) a la caja de salida con los dos tornillos (BB), y el tornillo de madera (DD), con el lado de la placa, que menciona "GND" debe enfrentar hacia fuera

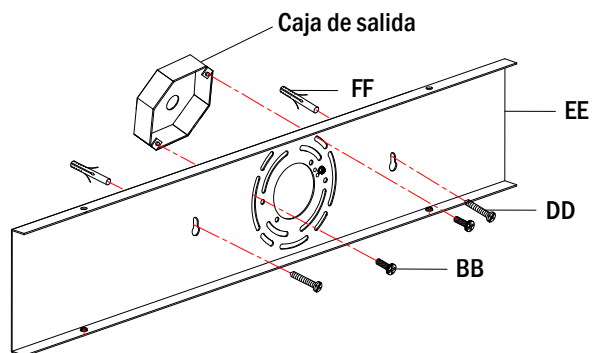

# Instalación (continuado)

## 4 Connecting the wires

- Conecte el cable blanco de la lámpara al cable blanco de la caja de salida, y el cable negro de la lámpara al cable negro de la caja de salida. Cubra las dos conexiones de cable con los dos Conectores de alambre previstos (AA). Envuelva las dos conexiones de los cables con cinta aislante para una conexión más segura. Si su caja de salida tiene un cable de tierra (verde o desnudo de cobre), conecte el cable de tierra accesorio a la misma utilizando el conector de cable (AA). De otra manera conecte el alambre de cobre al tornillo de tierra (CC) en la Placa de montaje (EE). Nota: Si usted tiene preguntas eléctricas, consulte a su código de electricidad local por los métodos aprobados de puesta a tierra.

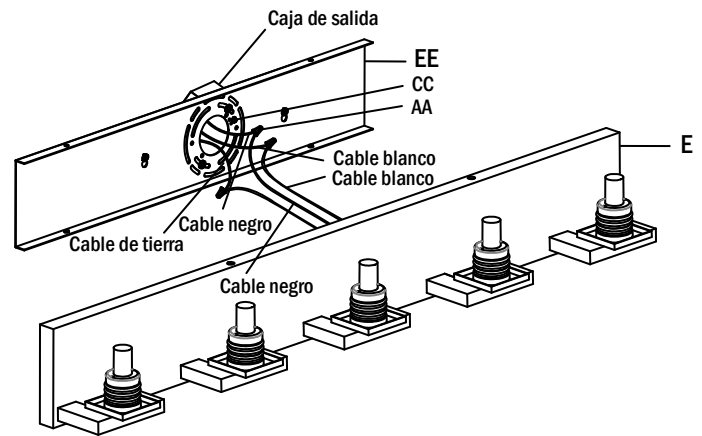

## 5 Coloque el cuerpo del accesorio en la placa de montaje

- Coloque el ensamble de la lámpara (E) sobre la placa de montaje (EE) y asegure con los tornillos (D).
- La instalación está completa. Encienda la energía en la caja de fusibles. Encienda el interruptor de la luz para activar el aparato.

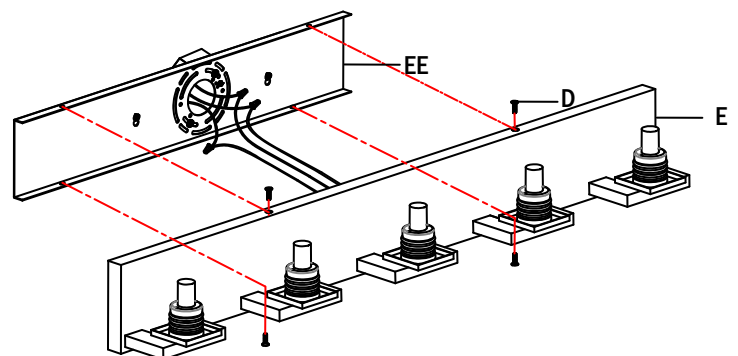

## Mantenimiento

- Apague la fuente de alimentación principal antes de realizar cualquier mantenimiento en la luz.
- Limpie con un paño húmedo o utilice limpiacristales. No utilice abrasivos.

## Cuidado y limpieza

- Para limpiar el exterior del aparato, utilice un seca o ligeramente húmeda tela (use agua limpia, nunca un disolvente) para limpiar el vidrio y la superficie de la lámpara.
- Para limpiar el interior del aparato, primero desconecte la alimentación de la lámpara de apagar el interruptor de circuito o quitando el fusible de la caja de fusibles. A continuación, utilice una tela seca o ligeramente húmeda (use agua limpia, nunca un disolvente) para limpiar el cristal en el interior y la superficie interior de la lámpara.
- No utilice limpiadores con productos químicos, solventes o abrasivos severos. Utilice sólo un paño suave y seco para el polvo o limpiar con cuidado.

## Solución de problemas

Problema	Causa posible	Acción correctiva
La oferta está encendido.	Está apagada.	Asegúrese de que el poder.
	Conexión del cable defectuoso.	Verifique el cableado.
	Interruptor defectuoso.	Pruebe o cambiar el interruptor.
Funde un fusible o circuito viajes interruptor cuando la luz.	Está encendida. Cables cruzados o cables de alimentación.	es tierra hacia fuera. Compruebe las conexiones de cables.

# Partes de servicio

## TIPO DE MODELO



AA



BB



CC



DD

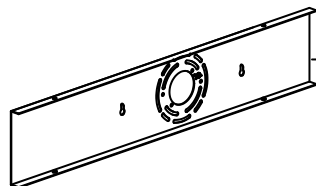

EE



FF



A

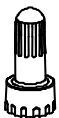

B

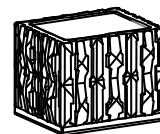

C



D

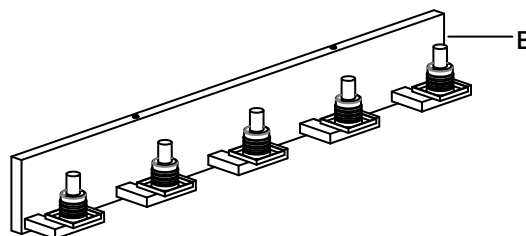

E

Parte	Descripción	Cantidad
AA	Conectores de cable de	3
BB	A cabo tornillos cuadro	2
CC	Tornillos de rosca de tierra	1
DD	Tornillo para madera	2
EE	Placa de montaje	1
FF	Ancla de plástico	2

Parte	Descripción	Cantidad
A	Tornillo de shell	5
B	Llave inglesa	1
C	Vidrio	5
D	Tornillo	4
E	Cuerpo del aparato	1



Preguntas, problemas, partes faltantes ? Antes de regresar a la tienda,  
Llamar al servicio de atención al cliente de Good Lumens Servicio al cliente  
8 a.m. - 7 p.m., EST, de lunes a viernes, de 9 a.m. a 6 p.m., EST, el sábado

**800-527-0998**

Conserve este manual para uso futuro.

LA-2814E/S/F

# GUIDE D'UTILISATION ET DE SOINS

## 5 LA VANITÉ DE BAIN LED (BRONZ METALLIQUE)

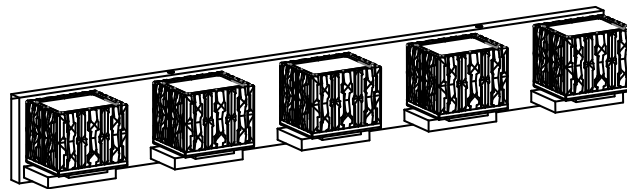

Des questions, des problèmes, des pièces manquantes? Avant de retourner au magasin,  
call Good Lumens Service à la clientèle  
8 h à 7 h, HNE, du lundi au vendredi de 9 h à 6 h, HNE, samedi

**800-527-0998**

---

### **JE VOUS REMERCIE**

*Nous apprécions la confiance que vous avez placée à Hampton Bay grâce à l'achat de ce luminaire. Nous nous efforçons de créer continuellement des produits de qualité conçus pour améliorer votre maison. Visitez-nous en ligne pour voir notre gamme complète de produits disponibles pour vos besoins d'amélioration de la maison. Merci d'avoir choisi Good Lumens!*

---

# Table des matières

Table des matières .....	2
Information de sécurité .....	2
Garantie .....	2
Pré-installation .....	3
OUTILS REQUIS POUR L'ASSEMBLAGE ET L'INSTALLATION(NON INCLUS) .....	3
MATÉRIEL INCLUS .....	4

CONTENU DU COLIS .....	5
Assemblée .....	6
Installation .....	7
Entretien .....	9
Entretien et nettoyage .....	9
Dépannage.....	9
Pièces de rechange .....	10

## Information de sécurité

Avant de commencer, assurez-vous de bien lire et comprendre les instructions de ce manuel. Veuillez suivre les instructions dans l'ordre présenté dans ce manuel et respecter tous les avertissements et mises en garde.



**ATTENTION:** Pour réduire le risque d'incendie, consultez un électricien qualifié avant l'installation.



**ATTENTION:** Si vous voulez utiliser un gradateur avec ce luminaire, consultez un professionnel pour déterminer le type de gradateur à utiliser et les caractéristiques électriques nécessaires.



**ATTENTION:** Avant de commencer l'installation, coupez l'alimentation électrique en plaçant le disjoncteur en position hors tension ou en retirant le fusible.



**ATTENTION:** Toutes les connexions électriques doivent être conformes aux codes locaux, aux ordonnances ou au Code national de l'électricité (NEC). Communiquez avec le service du bâtiment municipal pour connaître les codes, permis et / ou inspections locaux.



**ATTENTION:** Prenez soin de ne pas endommager ni couper la gaine protectrice (revêtement) des fils pendant l'installation du luminaire. Ne laissez pas les fils entrer en contact avec une surface ayant un rebord tranchant. Vous risqueriez d'endommager ou de couper la gaine protectrice des fils, ce qui entraînerait des risques de blessure grave ou de mort par choc électrique.



**ATTENTION:** Consultez un électricien qualifié avant l'installation.

## Garantie

### QU'EST-CE QUE COUVERTURE

Les garanties constructeur, ce montage doit être exempt de vices de matériaux et de fabrication pour une période de cinq (5) ans à compter de la date d'achat. Cette garantie s'applique uniquement à l'acheteur initial et uniquement aux produits utilisés dans les conditions normales d'utilisation et de service. Si vous trouvez que ce produit est défectueux, la seule obligation du fabricant et votre recours exclusif, est la réparation ou le remplacement, à la discrétion du fabricant, à condition que le produit a été endommagé par un mauvais usage, d'abus, les accidents, modifications, altérations, d'une négligence ou une mauvaise manipulation. Cette garantie ne s'applique pas à un produit se trouve avoir été mal installés, set-up, ou utilisé d'une manière non conforme aux instructions livrées avec le produit. Cette garantie ne s'applique pas à une défaillance du produit résultant d'un accident, une mauvaise utilisation, abus, négligence, altération ou une mauvaise installation, ou tout autre manquement qui se rapportent à des matériaux ou d'exécution défectueuse. Cette garantie ne s'applique pas à l'objectif dans une partie quelconque du produit, tels que la surface et / ou des intempéries, telles que cela est considéré comme une usure normale.

### CE QUI N'EST PAS COUVERT

Le fabricant ne garantit pas et décline notamment toute garantie, expresse ou implicite, d'adéquation à un usage particulier, sauf la garantie qui figure dans ce document. Le fabricant décline expressément toute responsabilité et ne saurait être tenue responsable pour tout dommage indirect ou accessoire ou des dommages, incluant mais non limité aux frais de main-d'oeuvre tous les coûts associés au remplacement ou la réparation du produit.

Communiquez avec l'équipe du service à la clientèle au (800)527-0998.



# Pré-installation

## OUTILS REQUIS POUR L'ASSEMBLAGE ET L'INSTALLATION(NON INCLUS)



Lunettes  
De Sécurité

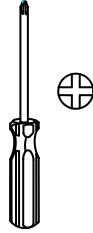

Tournevis  
cruiforme



Décapant  
s filaires



Escabeau

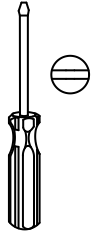

Tournevis à  
tête plate



Pinces  
coupantes



Ruban  
électrique

# Pré-installation (a continué)

## MATÉRIEL INCLUS



**REMARQUE:** Le matériel n'est pas représenté à la taille réelle.

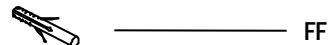
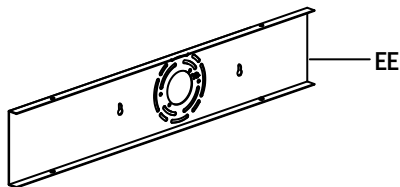
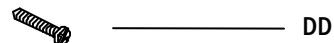
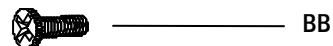
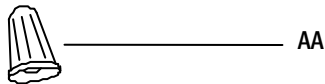

Partie	La description	Quantité
AA	Connecteurs de câble	3
BB	Les vis de la case	2
CC	Rez-vis	1
DD	Vis à bois	2
EE	Plaque de montage	1
FF	Plastic ancre	2

# Pré-installation (a continué)

## CONTENU DU COLIS

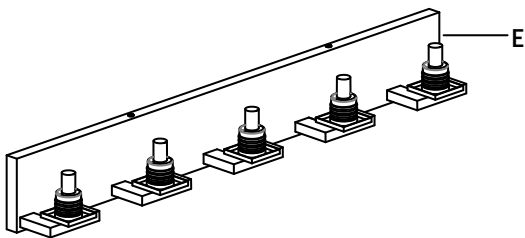
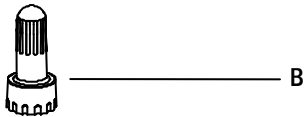
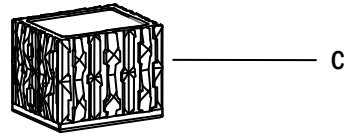
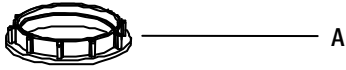

Partie	La description	Quantité
A	Vis Shell	5
B	Clé à écrous	1
C	Verre	5
D	Visser	4
E	Lampe corps	1

## 1 Fixation de l'ombre de verre

- Déballez attentivement votre nouveau support et disposez toutes les pièces dans un endroit dégagé. Faites attention de ne pas perdre toutes les petites pièces nécessaires pour l'installation.
- Retirez la et la vis (A) de l'appareil.
- Placez le globe de verre (C) sur le alvéole du corps de l'appareil (E). Fixez à l'aide de vis de Shell (A) en utilisant la clé inclus (B).

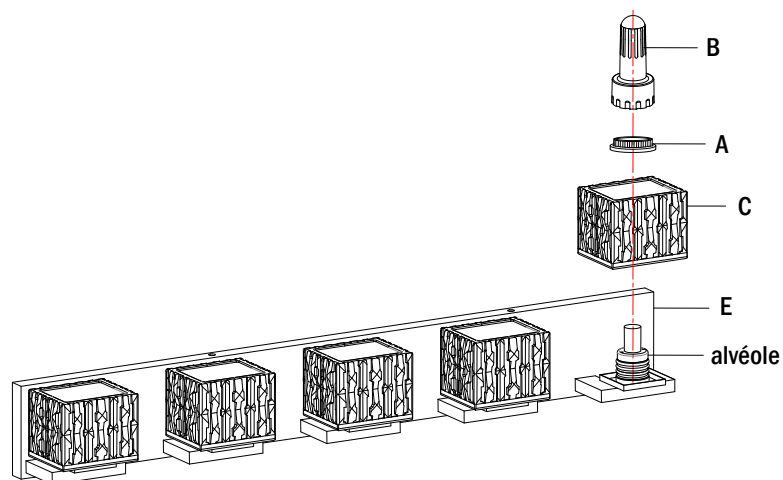

# Installation

## 1 Retrait de la plaque de montage

- Avant l'installation, retirer la plaque de montage (EE) en retirant les vis (D) du corps de l'appareil (E).

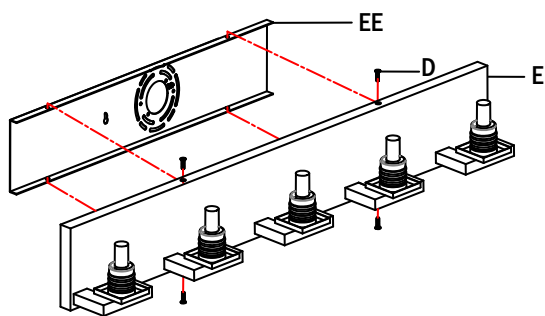

## 2 Positionner la plaque de montage

- Positionner la plaque de montage (EE) sur le mur et marquer l'emplacement des deux trous de fixation.
- Percez les trous dans le mur, insérez le ancrage de plastique (FF) dans le mur.

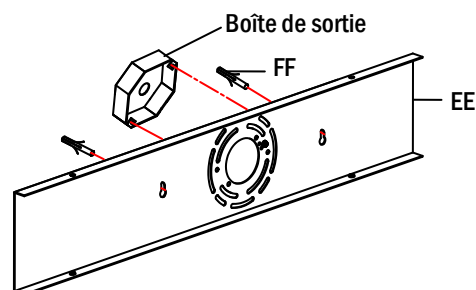

## 3 Installer la plaque de montage

- Fixez la courroie de la Plaque de montage (EE) à la boîte de sortie à l'aide de vis (BB) de la boîte de sortie Vis à bois (DD).

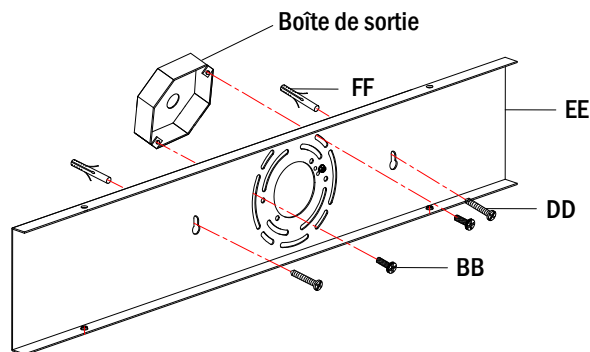

# Installation(a continué)

## 4 Raccordement des fils

- Connectez le fil blanc de la lampe au fil blanc de la boîte de sortie et le fil de montage noir au fil noir de la boîte de sortie. Couvrir les deux connexions par câble aux deux connecteurs de câble (AA). Envelopper les deux connexions à fils avec du ruban électrique pour une connexion plus sûre. Si votre boîte de sortie a un fil de terre (vert ou cuivre nu), connectez le fil de terre Mobilier à l'aide du connecteur (AA). Sinon, connectez le terrain de cuivre de l'appareil à vis de terre (CC) sur la sangle circulaire (EE). Note: Si vous avez des questions électriques, consultez votre code d'électricité local de méthodes approuvées de l'échouement

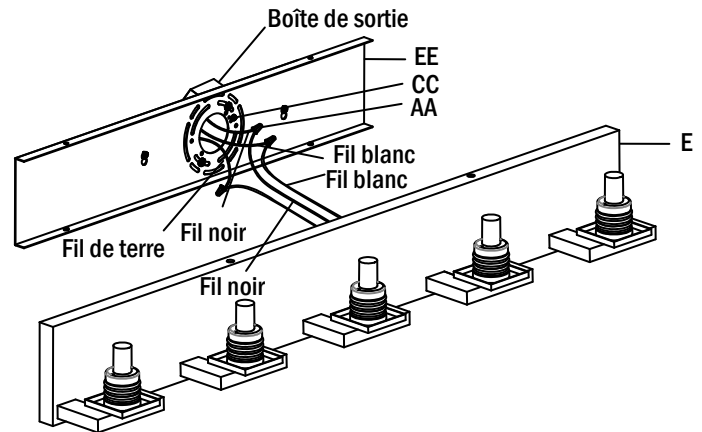

## 5 Placer le corps de fixation sur la plaque de montage

- Placer le corps du luminaire (E) par-dessus la plaque de montage (EE) et fixer à l'aide des vis (D).
- L'installation est terminée. Coupez l'alimentation sur la boîte à fusibles. Allumez Interrupteur pour activer l'appareil.

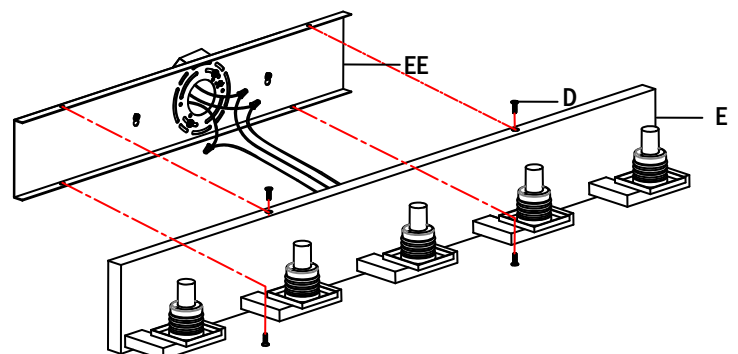

## Entretien

- Coupez l'alimentation électrique avant d'effectuer toute maintenance sur la lumière.
- Essuyez avec un chiffon humide ou utilisez un nettoyant pour vitres. Ne pas utiliser de produits abrasifs.

## Entretien et nettoyage

- Pour nettoyer l'extérieur de l'appareil, utilisez un chiffon sec ou légèrement humide (utilisation propre, jamais un solvant) pour nettoyer le verre et la surface de la lampe.
- Pour nettoyer l'intérieur de l'appareil, d'abord couper l'alimentation de la lampe à éteindre le disjoncteur ou en enlevant les fusibles de la boîte à fusibles. Ensuite, utilisez un chiffon sec ou légèrement humide (utilisation de l'eau propre, jamais un solvant) pour nettoyer le verre à l'intérieur et la surface intérieure de la lampe.
- N'utilisez pas de produits chimiques, solvants ou des abrasifs rudes. Utilisez un doux chiffon sec et à la poussière ou nettoyer avec soin.

## Dépannage

Problème	Ampoule s'allume pas	Action corrective
Cause possible Mesure corrective	Est éteint.	Assurez-vous que la puissance.
	Câble de raccordement défectueux.	Vérifiez le câblage.
	Défaut du commutateur.	Test ou remplacer interrupteur.
Fuse coups ou circuit voyages disjoncteur lorsque la lumière.	est allumé. Crossover des câbles ou des cordons d'alimentation.	est coincées. Vérifiez les connexions du câble.

# Pièces de rechange

## TYPE DE MODÈLE



AA



BB



CC



DD

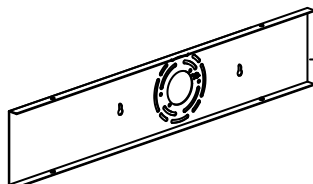

EE



FF



A



B

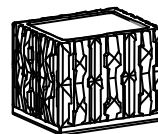

C



D

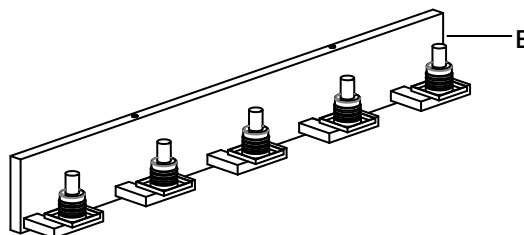

E

Partie	La description	Quantité
AA	Connecteurs de câble	3
BB	Les vis de la case	2
CC	Rez-vis	1
DD	Vis à bois	2
EE	Plaque de montage	1
FF	Plastic ancre	2

Partie	La description	Quantité
A	Vis Shell	5
B	Clé à écrous	1
C	Verre	5
D	Visser	4
E	Lampe corps	1





**Des questions, des problèmes, des pièces manquantes? Avant de retourner au magasin,  
Appelez Good Lumens Service à la clientèle  
8 h à 7 h, HNE, du lundi au vendredi de 9 h à 6 h, HNE, samedi**

**800-527-0998**

**Conserver ce manuel pour utilisation future.**