

# POWERSMART<sup>®</sup>

## INSTRUCTION MANUAL

**EN 24 inch Two Stage Gas Snow Thrower**

**FR 24 inch Souffleuse à Neige à Deux Phase**

**ES Quintanieves De Gas De 24 Pulgadas Con Dos Etapas**

Model # PSSHD24

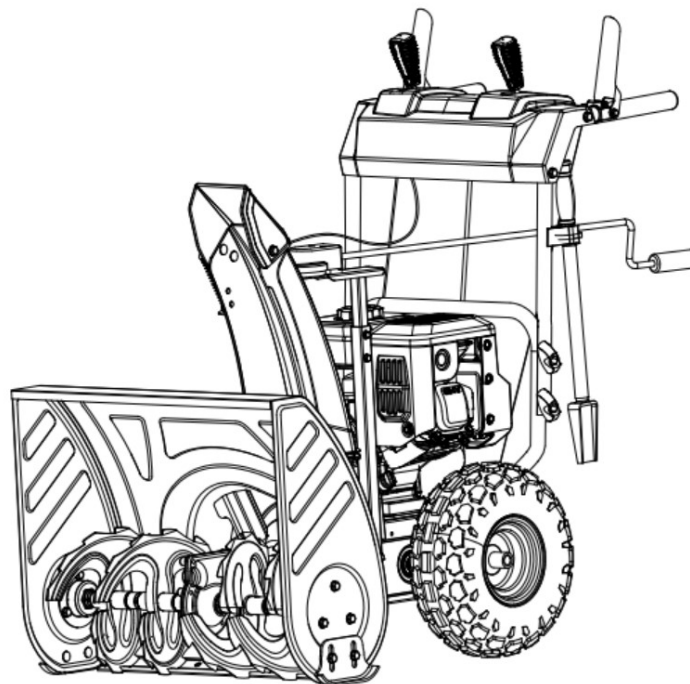

Have product questions or need technical support? Please feel free to contact us!

Website: [www.Amerisuninc.com](http://www.Amerisuninc.com)  
[www.PowerSmartUSA.com](http://www.PowerSmartUSA.com)

Toll free: 1-800-791-9458 Mon-Fri 9-5 EST

Email: [support@amerisuninc.com](mailto:support@amerisuninc.com)



# TABLE OF CONTENTS

EN

Technical data.....	3
Introduction.....	4
Safety information.....	4
Knowing your snow thrower.....	10
Assembly and adjustments.....	12
Snow thrower preparation.....	18
Operating your snow thrower.....	21
Maintenance.....	23
Storage & Cleaning.....	27
Troubleshooting.....	28
Exploded view and parts list.....	31
Two (2) years limited warranty.....	40

## TECHNICAL DATA

### 24 inch Two Stage Electric Start Snow Thrower

Model #:	PSSHD24
Engine:	212cc Snow Engine
Engine oil Capacity:	16 fl.oz
Fuel Tank Capacity:	0.66 Gallon
Start System:	120V Electric / Recoil
Clearing Width:	24 inch
Clearing Height:	20 inch
Chute Rotation Angle:	180°
Speed:	6 Forward, 2 Reverse
Tire Size:	13 inch
Overall Dimensions (L x W x H):	32.3x24.8x22in
Weight:	146.3 lbs

Thank you for purchasing PowerSmart products.

It is crucial and highly recommended that you read this instruction manual in its' entirety, as this is an invaluable tool and reference point in understanding the operation of your unit.

Please register your unit online at [www.Amerisuninc.com](http://www.Amerisuninc.com). This process will allow us to track your warranty information and update our records regarding your unit accordingly.

Important: Our company does not provide email or personal information to any third party for any reason. For any questions check our website or call customer service at (800)791 9458.

## INTRODUCTION

Thank you for purchasing a PowerSmart® Product. This manual provides detailed information regarding the safe operation and maintenance of this product. Every effort has been made to ensure the accuracy of the information in this document. PowerSmart® reserves the right to change this product and specifications at any time without prior notice.

Please keep this manual available to all users during the entire life of the product.



This manual contains special messages to bring attention to potential safety concerns, product damage as well as helpful operating and servicing information. Please read all the information carefully to avoid injury and machine damage.

## **QUESTIONS? PROBLEMS?**

To answer questions and resolve issues in the most efficient and timely manner, please contact Customer Service at (800) 791-9458, Mon-Fri 9am-5pm EST or email: [support@amerisuninc.com](mailto:support@amerisuninc.com).

## **NOTICE REGARDING EMISSIONS**

Engines that are certified to comply with U.S. EPA emission regulations for SORE (Small Off Road Equipment), are certified to operate on regular unleaded gasoline, and may include the following emission control systems: (EM) Engine Modifications and (TWC) Three-Way Catalyst (if so equipped).

## SAFETY INFORMATION



This symbol points out important safety instructions which, if not followed, could endanger the personal safety and or property of yourself and others. Read and follow all instructions in this manual before attempting to operate this machine. Failure to comply with these instructions may result in personal injury.



**WARNING!** This machine was built to be operated according to the safe operation practices in this manual. As with any type of power equipment, carelessness or error on the part of the operator can result in serious injury. This machine is capable of amputating fingers, hands, toes and feet and throwing foreign objects. Failure to observe the following safety instructions could result in serious injury or even a fatal occurrence.

It is your responsibility to restrict the use of this power machine to persons who read, understand and follow the warnings and instructions in this manual and on the machine.



**ROTATING PARTS!** Only use clean-out tool to clear blockages. **NEVER** use your hands.



**NEVER** direct discharge towards persons or property that may be injured or damaged by thrown objects.



Keep people away from unit while operating. Keep children out of work area and under watchful care of a responsible adult.

## **TRAINING**

Read, understand, and follow all instructions on the machine and in the manual(s) before attempting to assemble and operate. Keep this manual in a safe place for future and regular reference.

- Be familiar with all controls and their proper operation. Know how to stop the machine and disengage them quickly.
- Never allow children under 14 years of age to operate this machine. Children 14 and over should read and understand the instructions and safe operation practices in this manual and on the machine and be trained and supervised by an adult.
- Never allow “non-trained” adult personnel to operate this machine without proper instruction.
- Thrown objects can cause serious personal injury. Plan and map out your snow-throwing pattern to avoid discharge of material toward roads, bystanders and the like.
- Keep bystanders, pets and children at least 75 feet from the machine while it is in operation. Stop machine if anyone enters the area.
- Exercise caution to avoid slipping or falling, especially when operating in reverse.

## **PREPARATION**

Thoroughly inspect the area where the equipment is to be used. Remove all doormats, newspapers, sleds, boards, wires, branches and other foreign objects, which could be hazardous and damage the auger system.

- Always wear safety glasses or eye shields during operation and while performing an adjustment or repair to protect your eyes, as thrown objects can ricochet and cause serious injury to the eyes.
- Do not operate without wearing adequate, winter outer garments. Do not wear jewelry, long scarves or other loose clothing, which could become entangled in moving parts, and wear footwear that will improve footing on slippery surfaces.
- Use a grounded “three-wire” extension cord and receptacle for all machines with electric start engines.
- Adjust skid shoe and/or housing height to clear gravel or crushed rock surfaces.
- Disengage all control levers before starting the engine.
- Never attempt to make any adjustments while engine is running, except where specifically recommended in the instruction manual.
- Let engine and machine adjust to outdoor temperature before starting to clear snow.

## PERSONAL SAFETY

- Engine exhaust, and certain vehicle components contain or emit chemicals known to cause cancer, birth defects or other reproductive harm.
- Read, understand and follow all instructions on your snow thrower unit and in this instruction manual before attempting to assemble and operate your machine.
- Keep this instruction manual in a safe place for future and regular reference. If replacement parts are needed, refer to the Panel, Chute, Frame and Housing Diagrams and Parts' Listings on pages 25-30.
- Stay alert, watch what you are doing and use common sense when operating your snow thrower unit.
- Do not use your snow thrower unit while you are tired or under the influence of drugs, alcohol, medication. A moment of inattention while operating the snow thrower may result in severe bodily injury.
- **NEVER LEAVE YOUR RUNNING SNOW THROWER UNATTENDED. Stop the engine!**
- Do not leave your snow thrower unit until it has come to a complete stop.
- When stepping backwards, be cautious about any obstacles beneath your feet or behind you avoid falling.

## SERVICE

- Stop the engine before making any adjustments. Check for misalignment, breakage or binding of moving parts, and any other conditions that may affect operation.
- If damaged, have the snow thrower unit serviced by an authorized service center using only specified, manufactured replacement parts. This will ensure that the safety of the snow thrower unit is maintained.

## SAFE HANDLING OF GASOLINE

To avoid personal injury or property damage use extreme care in handling gasoline. Gasoline is extremely flammable and the vapors are explosive. Serious personal injury can occur when gasoline is spilled on yourself or your clothes which can ignite, therefore wash your skin and change clothes immediately.

- Use only an approved gasoline container.
- Extinguish all cigarettes, cigars, pipes and other sources of ignition.
- Never fuel snow thrower unit's engine indoors.
- Never remove gas cap or add fuel while the engine is hot or running.
- Allow engine to cool at least two minutes before refueling.

- Never over fill fuel tank.
- Replace gasoline cap and tighten securely.
- If gasoline is spilled, wipe it off the engine and equipment. Move machine to another area. Wait 5 minutes before starting the engine.
- Never store the machine or fuel container inside where there is an open flame, spark or pilot light (e.g. furnace, water heats, space heater, clothes dryer etc.).
- Allow machine to cool at least 5 minutes before storing.
- Never fill containers inside a vehicle or on a truck or trailer bed with a plastic liner. Always place containers on the ground away from your vehicle before filling.
- If possible, remove gas-powered equipment from the truck or trailer and refuel it on the ground.
- If this is not possible, then refuel such equipment on a trailer with a portable container, rather than from a gasoline dispenser nozzle.
- Keep the nozzle in contact with the rim of the fuel tank or container opening at all times until fueling is complete. Do not use a nozzle lock open device.

## **OPERATION**

- Do not put hands or feet near rotating parts, in the auger impeller housing or chute assembly. Contact with the rotating parts can amputate hands and feet.
- The auger (impeller) control lever is a safety device. Never bypass its operation. Doing so makes the machine unsafe and may cause personal injury.
- The control levers must operate easily in both directions and automatically return to the disengaged (vertical) position when released.
- Never operate with a missing or damaged chute assembly. Keep all safety devices in place and working.
- Never run an engine indoors or in a poorly ventilated area. Engine exhaust contains carbon monoxide, an odorless and deadly gas.
- Do not operate machine while under the influence of alcohol or drugs.
- Muffler and engine become hot and can cause burning. Do not touch. Keep children away.
- Exercise extreme caution when operating on or crossing gravel surfaces. Stay alert for hidden hazards or traffic.
- Exercise caution when changing direction and while operating on slopes.

- Plan your snow-throwing pattern to avoid snow discharge towards windows, walls, cars etc., thus avoiding possible property damage or personal injury caused by a ricocheting debris.
- Never direct discharge at children, bystanders and pets or allow anyone in front of the machine.
- Do not overload machine capacity by attempting to clear snow at too fast of a rate.... **Remember! Slow and steady operation is best to avoid clogs of snow being impelled too rapidly.**
- Never operate this machine without good visibility or light. Always be sure of your footing and keep a firm hold on the handles. Walk, never run.
- Disengage power to the auger system (auger/impeller) by releasing the auger control (lever) when transporting or not in use.
- Never operate machine at high transport speeds on slippery surfaces. Look down and behind and use care when backing up.
- If the machine should start to vibrate abnormally, stop the engine, disconnect the spark plug wire and ground it against the engine. Inspect thoroughly for damage. Repair any damage before starting and operating.
- Disengage all (drive and auger) control levers and stop engine before you leave the operation position (behind the handles).
- Wait until the auger /impeller comes to a complete stop before unclogging the chute assembly, making any adjustments or inspections.
- Never put your hand in the discharge or collector openings. Always use the clean-out tool provided to unclog the discharge opening. Do not unclog chute assembly while engine is running. Shut off engine and remain behind handles until all moving parts have stopped before unclogging.
- Use only attachments and accessories approved by the manufacturer (e.g. wheel weights, tire chains, cabs etc.).
- When starting engine, pull cord slowly until resistance is felt, then pull rapidly, Rapid retraction of starter cord (kickback) will pull hand and arm toward engine faster than you can let go. Broken bones, fractures, bruises or sprains could result.
- If situations occur which are not covered in this manual, use care and good judgment contact customer support for assistance.

## **MAINTENANCE & STORAGE**

- Never tamper with safety devices. Check their proper operation regularly. Refer to the maintenance and adjustment sections of manual.
- Before cleaning, repairing, or inspecting machine disengage all control levers and stop the engine.
- Wait until the auger impeller comes to a complete stop. Disconnect the spark plug wire to prevent unintended starting.
- Check bolts and screws for proper tightness (EVERYTIME before & after use) as engine vibration could cause hardware to loosen...consider using a Loc-Tite product to keep hardware secure.



This process will keep the machine in safe working condition. Also, visually inspect machine for any damage.

- Verify that the auger gearbox, located between your right and left auger blades, has substantial lubricant in the casing.

The gearbox fill and drain plugs (bolts) are the only “vertical” plugs (bolts) on the gearbox assembly when viewed in the standing position. The top plug (bolt) is used for filling...the bottom plug (bolt) is for draining. Simply remove the top plug (bolt) for verification of lubricant, as it should be inside. To drain, simply remove bottom plug (bolt).

- Do not change the engine governor setting or overspeed the engine. The governor controls the maximum safe operating speed of the engine.
- **Snow thrower auger belts, shave plates, shear pins and skid shoes are subject to wear and damage, therefore it is expected that the owner assume personal responsibility for the maintenance (removal & installation) of these items.**
- For your safety protection, frequently check all components and replace with original equipment manufacturers (OEM) parts only. Use of parts which do not meet the original equipment specifications may lead to improper performance and compromise safety.
- Check (drive & auger) control lever (handles) and cables periodically to verify they engage and disengage properly and adjust, if necessary. Refer to the adjustment section in this operator's manual for instructions.
- Maintain or replace safety and instruction labels, as necessary.
- Observe proper disposal laws and regulations for gas, oil, etc. to protect the environment.
- Prior to storing, run machine a few minutes to clear snow from machine and prevent freeze up of auger impeller and completely wipe down unit, while inspecting for frozen components.
- Never store the machine or fuel container inside where there is an open flame, spark or pilot light such as water heater, furnace, clothes dryer etc.
- Always refer to the operator's manual for proper instructions on off-season storage. A YouTube video is available, which illustrates this process:  
<https://www.youtube.com/watch?v=X4KYcFEfeY4>
- Check fuel line, tank, cap and fittings frequently for cracks or leaks. Replace if necessary.
- Do not crank engine with spark plug removed.
- Have the machine inspected annually by an authorized service dealer to ensure that all mechanical and safety systems are working properly and have not worn excessively\*. Failure to do so can result in accidents, injuries or death.

**\*Please note that an annual inspection is not covered within the warranty program...only REPAIR service.**

## **DO NOT MODIFY THE ENGINE**

To avoid serious injury or death, do not modify engine in any way. Tampering with the governor setting can lead to a runaway engine and cause it to operate at unsafe speeds. Never tamper with factory setting of engine governor.

# KNOWING YOUR SNOW THROWER

Use the illustrations below to become familiar with the locations and functions of the various components and controls of this snow thrower.

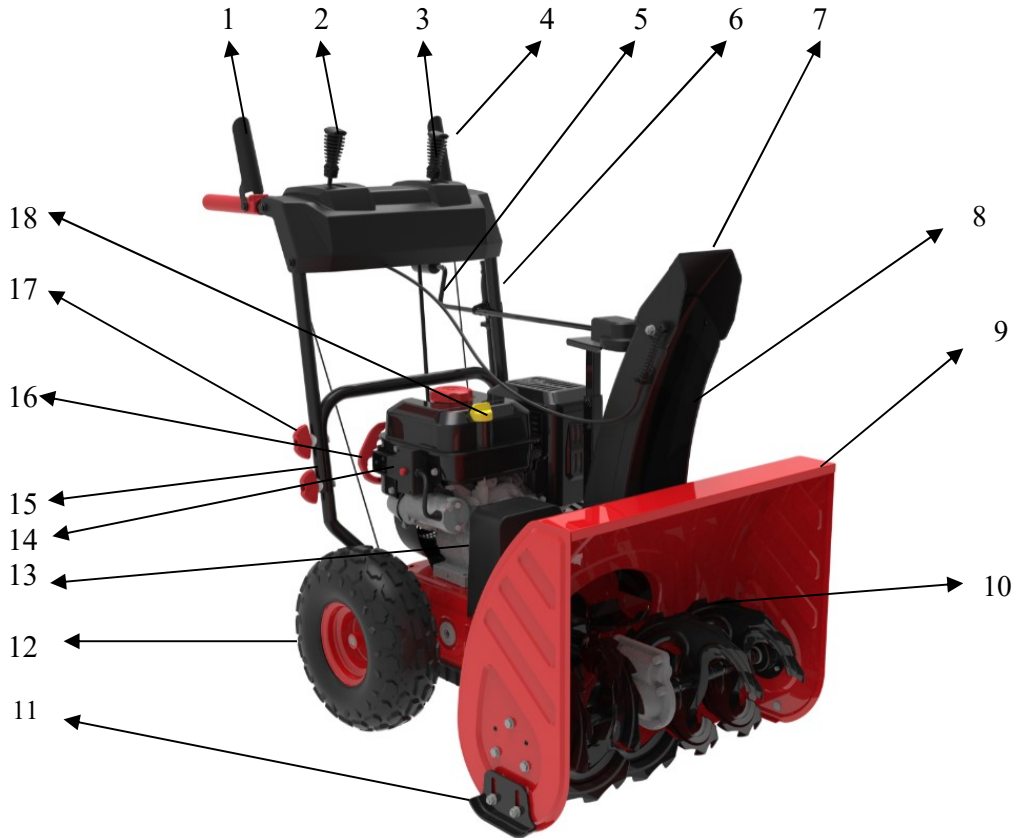

- |   |                           |    |                       |
|---|---------------------------|----|-----------------------|
| 1 | Drive Control Lever       | 10 | Auger Blade           |
| 2 | Drive Speed/Gear Control  | 11 | Skid Shoe             |
| 3 | Chute Deflector Control   | 12 | Wheel Tire            |
| 4 | Auger Control Lever       | 13 | Belt Cover            |
| 5 | Chute Rotation Handle     | 14 | Electric Start Button |
| 6 | Clean Out Tool            | 15 | Lower Handle          |
| 7 | Discharge Chute Deflector | 16 | Recoil Start Handle   |
| 8 | Discharge Chute           | 17 | Handle Knob           |
| 9 | Auger Housing             | 18 | Oil Dipstick          |

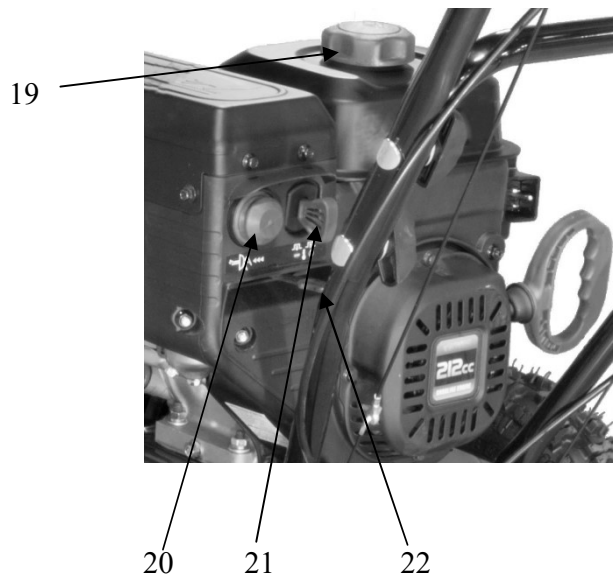

19	Fuel Tank Cap	21	Switch Key
20	Primer Bulb	22	Choke Lever

### **Drive Control Lever**

Located on the right side of the upper handle, the Drive Control Handle is used to engage and disengage the drive wheels. Squeeze the Drive Control Handle against the upper handle to engage the wheels; release to disengage.

### **Drive Speed/Gear Control**

The Speed/Gear Control is located on the center of the panel and is used to set the drive speed and direction of travel. It can be moved into any of **eight** positions (four forward and two reverse gear settings)

### **Auger Control Lever**

Located on the left side of the upper handle, the Auger Control Handle is used to engage and disengage the augers. Squeeze the Auger Control Handle to engage the augers; release to disengage the augers.

### **Chute Rotation Handle**

To adjust snow discharge direction, rotate the handle clockwise or counter-clockwise....should rotate 180 degrees.

### **Skid Shoe**

Position the shoes based on the surface conditions. Adjust upward for hard-packed snow. Adjust downward when operating on gravel or crushed rock surfaces.

### **Auger Blade and Impeller**

When engaged, the auger blades rotate to cut snow and direct it into the auger/impeller housing to be discharged out the chute.

### **Clean-out Tool**

The chute Clean-out Tool is conveniently fastened to the rear of the auger housing with a mounting clip. It is used to clean the chute assembly and chute opening when snow and ice become lodged.

**WARNING!** Never use your hands to clear a clogged chute assembly. Shut off engine and remain behind handles until all moving parts have stopped before unclogging.

## ASSEMBLY AND ADJUSTMENTS

The following section describes steps necessary to prepare the snow thrower for use. If after reading this section, you are unsure about how to perform any of the steps please call (800) 791-9458 Mon-Fri 9-5 EST for customer service assistance. Failure to perform these steps properly can damage the snow thrower.

### **Unpacking**

Unpack the snow thrower and all its parts, and compare against the list below.

1. Snow Thrower
2. Discharge Chute Assembly
3. Chute Rotation Handle
4. (Qty. 2) one set of Skid Shoes with attaching hardware
5. (Qty. 4) extra M6 Shear Pins and M6 Locknuts
6. Two tires with dowel pins.
7. Speed control connection Rod.
8. 20oz 5W-30 oil

### **ASSEMBLY**

Your Snow Thrower will require some assembly. Please complete the following steps before using your Snow Thrower.



**WARNING:** This snow thrower is heavy. Assembly procedures may require lifting equipment utilizing two people.

### **Step 1: Installing the Tire**

1. Installing left and right tire as indicated on Figure 1. Please move left tire to right if axle move to left when you install right tire.
2. Insert bolt and dowel pin as indicated on Figure 2.

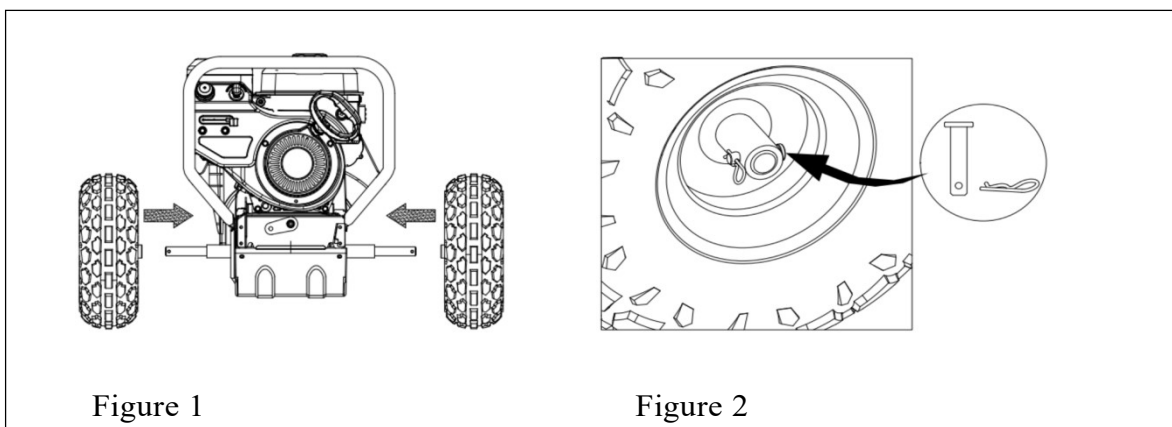

## Step 2: Installing the Upper Handle

1. When installing the Upper Handle, please note that the Drive & Auger Cables will already be pre-attached to Upper Handle.
2. Attach Upper Handle using the Frame Handle Assembly Hardware (4 sets /Knob, Saddle Washer, M8 Nut, T-Screw) for your Upper & Lower Handle connection.
3. When attaching Assembly Hardware, make sure ALL cables are underneath the Frame (Upper & Lower) Handles after installation as indicated in Figure 3. VERY IMPORTANT!!!\*\*

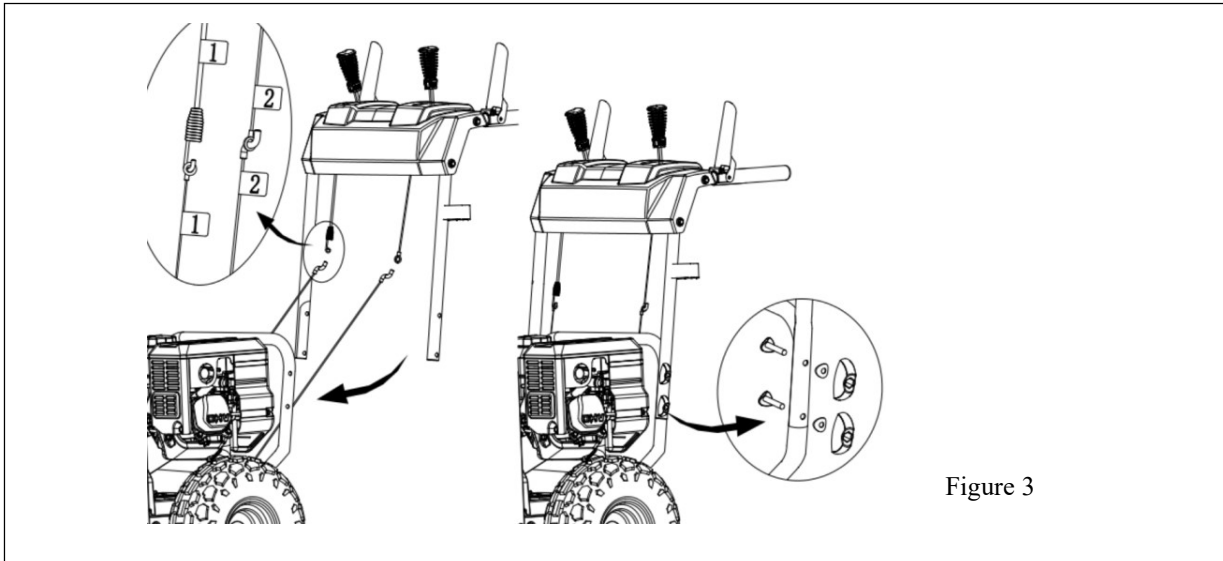

Figure 3

### \*\*\*Assembling Drive & Auger Cables over the top of the Frame

Handle will cause unnecessary tension in the cables, resulting in the Snow blower propelling forward when starting the engine and may cause damage to the drive& auger control (levers) when trying to engage them.

4. Cut and remove all tie wraps that are on Cables, Frame Handles, Drive Control (Lever) & Auger Control (Lever).
5. Verify that the connection for the Upper & Lower Drive/Auger Cables is accurate. (See Figure 3)

### Step 3: Installing Speed Control Connection Rod

1. Install the connection rod to the hole in the Frame as indicated on Figure 4 -1.
2. Install another side of connection rod to the hole in the trigger as indicated on Figure 4-2.

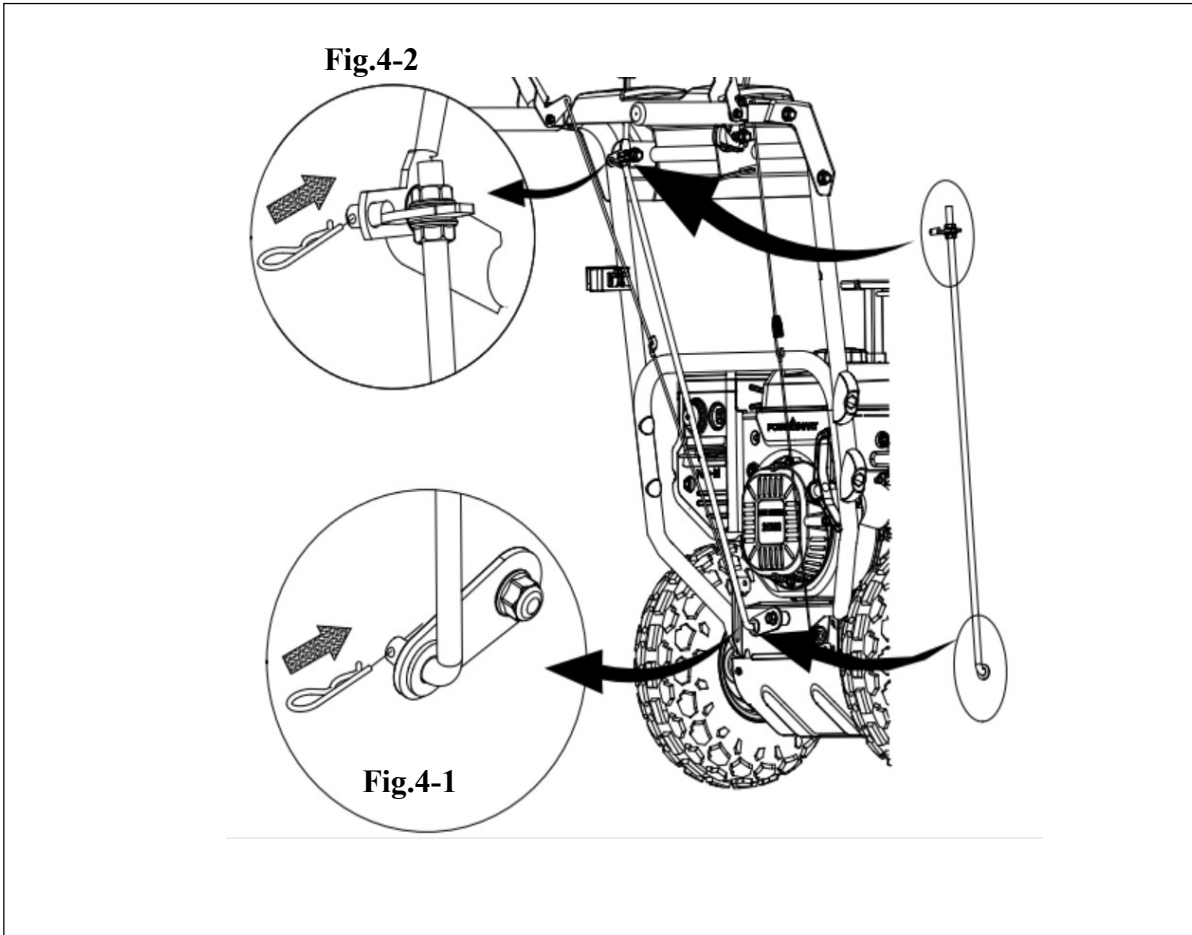

#### Step 4: Installing The Chute Assembly

1. Insert Lower Discharge Chute/Support Tube Assembly into the designated Chute opening for the Lower Discharge Chute, while inserting the Support Tube into the designated base of the Frame. (See Figure 5).
2. Secure Support Tube to base with (2) Screws and nuts provided.

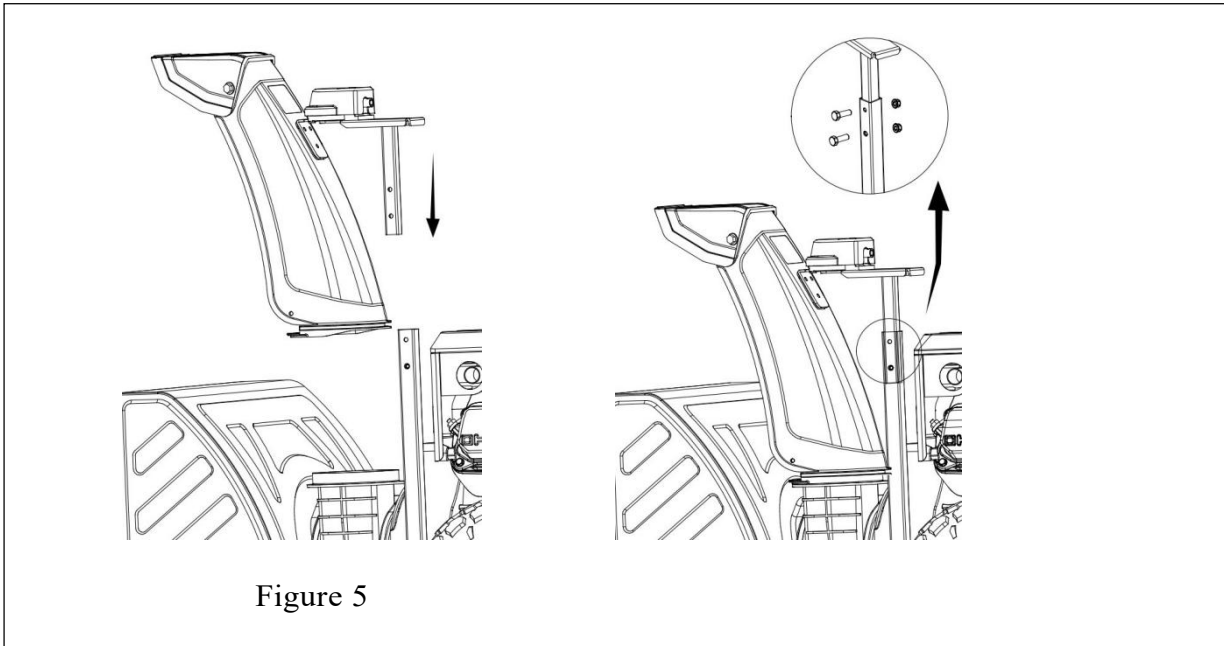

Figure 5

#### Step 5: Installing the Chute Handle

1. Slide Chute Handle through Chute Handle Guide near the Upper Panel, as indicated on Figure 6.
2. Attach Chute Handle to base of Chute Gear Connection and secure with Cotter Pin, as indicated on Figure 6.

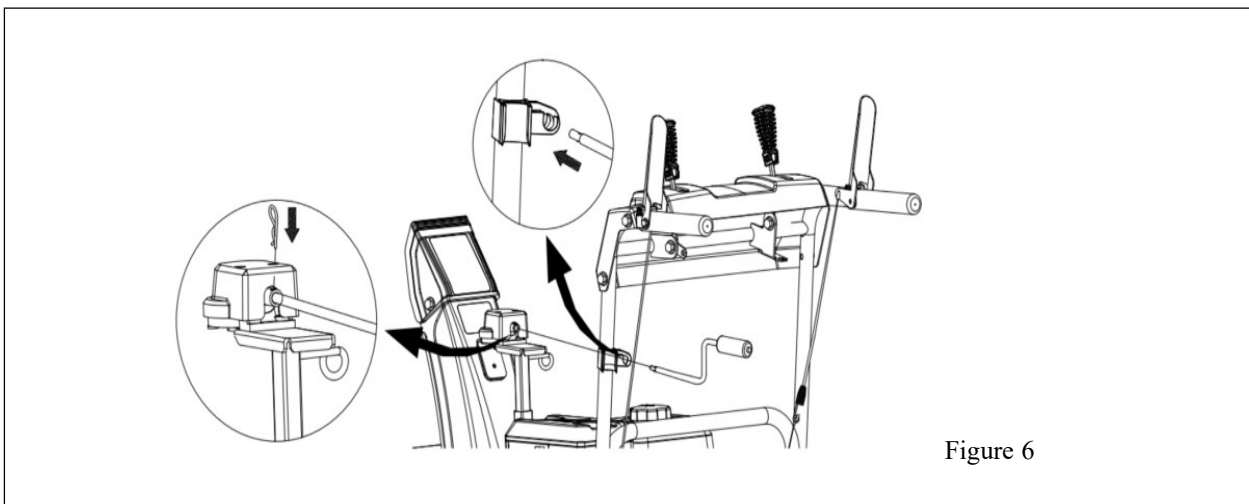

Figure 6

3. Verify that ALL cables are clear and not obstructing the Chute Handle operation of your snow thrower unit. Clip the cable into the hook. (See Figure 7)

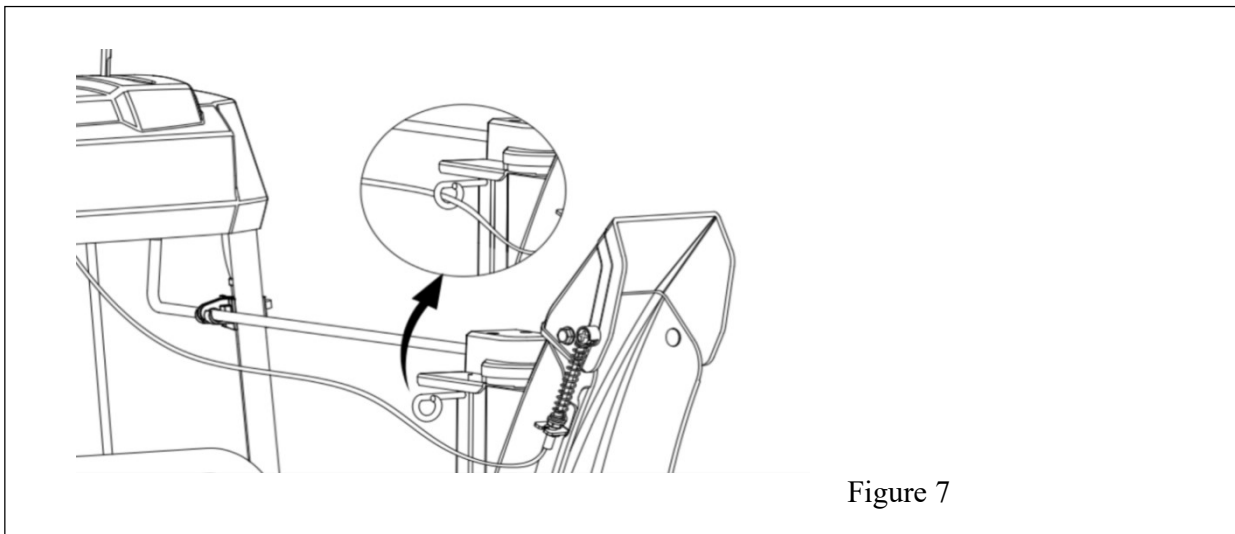

Figure 7

### Step 6-Installing Clean Out Tool

1. Insert the clean out tool into the lower handle bracket

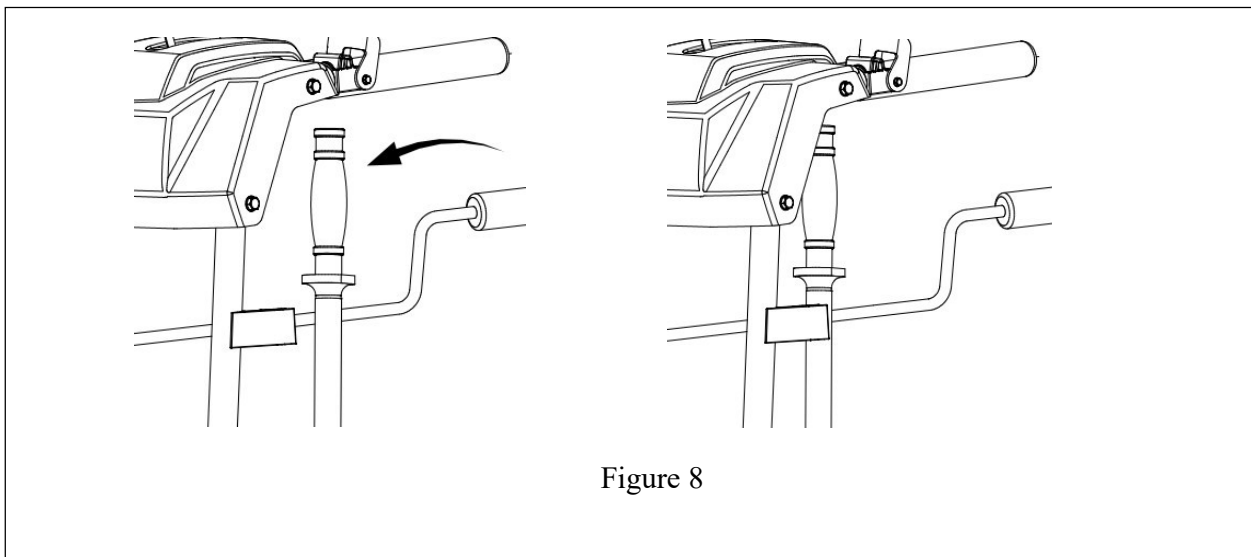
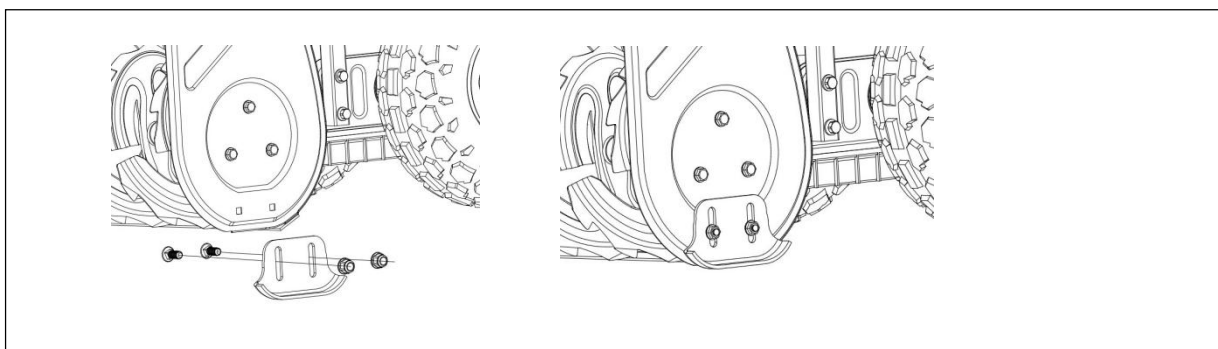

Figure 8



## Step 7 – Skid shoes installation and adjustments

1. Locate the set of skid shoes from parts bag and remove the bolts.
2. Loosely install the skid shoes using the bolts and hex nuts as shown on each side of the auger housing. Make sure the skid shoe tip faces out.  
Adjustment of the skid shoes sets the height above the ground at which the auger shave plate operates. For clearing snow from concrete, asphalt, and other smooth surfaces, set the auger shave plate so that the bottom of the plate is just above the ground. For clearing snow from gravel, dirt, and other rough surfaces set the auger shave plate slightly above the ground to avoid dirt and gravel from entering the auger. The optimal height of the plate will vary depending on the type of surface being cleared. Surfaces with larger gravel or stones require a higher shave plate setting.
3. Move the snow thrower to a solid, smooth, and level surface.
4. Place a spacer board on the ground underneath the auger shave plate between the skid shoes. The thickness of the board should be the same as the height above the ground you wish to raise the auger shave plate. The skid shoes should not touch the board.
5. With the two nuts loose allow the skid shoe to slide to the ground then tighten the nuts to secure the skid shoe.



# SNOW THROWER PREPARATION

## **ADD OIL**

The snow thrower is shipped without oil. User must add the proper amount of oil before operating the snow blower for the first time. The oil capacity of the engine crankcase is 16 fl. oz. For general use, we recommend 5W-30, 4-stroke engine oil.

## **ENGINE OIL RECOMMENDATIONS**

Select good quality detergent oil bearing the American Petroleum Institute (API) service classifications SJ, SL, or SM (synthetic oils may be used). Use the ASE viscosity grade of oil from the following chart that matches the starting temperature anticipated before the next oil changes.

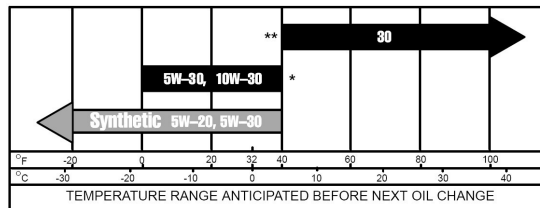

## **To add oil, follow these steps:**

1. Make sure the snow thrower is on a level surface. Tilting the snow thrower to assist in filling will cause oil to flow into engine areas and will cause damage. Keep snow thrower level!
2. Remove the dipstick from the engine.
3. Add oil slowly as to not overflow the unit.
4. To check the oil level, wipe the dipstick with a clean rag. Insert the dipstick into the oil fill opening without screwing it in. Remove the dipstick to check the oil mark.
5. Slowly add more oil and repeat step 4 until the oil mark reaches to the top of the dipstick. Do not overfill the crankcase.
6. Check for oil leaks. Tighten dipstick firmly.



## **ADD GASOLINE**

Use fresh (within 30 days from purchase), lead-free gasoline with a minimum of 87 octane rating. Do not mix oil with gasoline.

To add gasoline, follow these steps:

1. Make sure the snow thrower is on a level surface.
2. Unscrew fuel tank cap and set aside. NOTE: The fuel cap may be tight and hard to unscrew.
3. Slowly add unleaded gasoline to the fuel tank. Be careful not to overfill. The capacity of the fuel tank is 0.66 gallons. NOTE: Do not fill the fuel tank to the very top. Gasoline will expand and spill over during use even with the fuel cap in place.
4. Reinstall fuel cap and wipe clean any spilled gasoline with a dry cloth.

## **IMPORTANT:**

- Never use an oil/gasoline mixture.
- Never use old gasoline.
- Avoid getting dirt or water into the fuel tank.
- Gasoline can age in the tank and make starting difficult. Never store snow thrower for extended periods of time with fuel in the tank or the carburetor.

- **NOTE:** After completing the above preparation, the engine is ready to be started.

**WARNING!** Keep the area of operation free from foreign objects that can be thrown by the auger and/or impeller blades. Perform a thorough inspection of the area since some objects may be hidden from view by surrounding snow. If the snow thrower hits an obstruction or picks up a foreign object during use, stop the snow thrower immediately, remove the obstruction, and inspect it for damage. Repair or replace any damaged parts before restarting and operating you snow thrower.

- Keep children, pets, and bystanders away from the area of operation. Be aware that the normal noise of the snow thrower when turned on may make it difficult for you to hear approaching people.
- Start your clearing path by throwing snow in a back and forth motion. To clear in the opposite direction, stop your snow thrower and pivot it on its' wheels to face the opposite direction. Make sure to overlap clearing paths.
- Determine the direction of the wind. If possible, move in the same direction as the wind so that the snow is not thrown against the wind, back into your face and on the just cleared path.

**WARNING! DO NOT USE YOUR HANDS TO UNCLOG CHUTE.** Stop the motor before removing debris. Use the supplied Clean-out tool to unclog the chute. Do not walk in front of your running snow thrower. Do not direct discharged snow towards bystanders.

- Do not apply additional man-made load to the engine since this may damage the engine.
- Some parts of your snow thrower may freeze under extreme temperature conditions. Do not attempt to operate your snow thrower with frozen parts. If the parts freeze while your snow thrower is in use, stop the unit and inspect it for frozen parts. Thaw all parts before restarting and operating your snow thrower. Never force parts or controls that are frozen. Never use an open flame of any sort to thaw frozen parts.

#### Pre-Operation Inspection - **IMPORTANT!!!**

Before using your snow thrower for the first time, check the following:

- Have you read and followed all setup and operation procedures for the engine as outlined?
- Has the engine been filled with oil and gasoline to the proper level?
- Are all snow thrower components properly attached and assembled?
- Are there any broken or damaged parts?
- Are all fasteners tight?
- Are the tires inflated to the proper pressure?

**NOTICE:** If you are unsure about the assembly or condition of any of your snow thrower parts, please call our customer service department at (800)791 9458.

#### **AUGER AND DRIVE CONTROLS**

1. To engage the auger (blades), press down on the auger control lever (left side handle).
2. To engage the drive, press down on the drive control lever (right side handle). The machine should start moving in the direction and speed for the respective setting on the speed/gear control.

3. When finished clearing a snow path, release the auger control lever (handle) and the drive control lever (handle).



Attention: Release (disengage) the auger and drive control lever (handles) before adjusting the drive speed control lever. **NEVER** change the drive/gear speed while your snow thrower is in motion, as it will damage the drive mechanism and void the warranty.

### DRIVE SPEED/GEAR CONTROL

Move the drive speed control lever to the desired speed. There are eight (8) settings: six (6) forward speeds and two (2) reverse speeds. 1 is the slowest forward speed and 6 is the fastest forward speed. R1 is the slowest reverse speed and R2 is the fastest reverse speed.

Note: There is no neutral drive setting since the drive control handle must be engaged for movement. Neutral is achieved when the drive control handle is disengaged.



### CHUTE DISCHARGE DIRECTION ADJUSTMENT



**WARNING** - Never direct the snow discharge chute at the operator, bystanders, vehicles or nearby windows. Discharged snow and foreign objects accidentally picked up by the Snow Thrower can cause serious damage and severe bodily injury. Always point the discharge chute in the opposite direction from potential hazards. The discharge chute can be adjusted 180° by rotating the chute rotation handle. Rotate the chute rotation handle clockwise to move the discharge chute to the left; counterclockwise to move the chute to the right.

# OPERATING YOUR SNOW THROWER

## **MANUAL START THE ENGINE**

To manual start the engine, perform the following steps:

1. Check the oil and fuel levels.
2. Move the choke lever to the “CLOSE” position.
3. Make sure insert the switch key.
4. Press the primer bulb 3 times.
5. Pull on the recoil starter handle slowly until a slight resistance is felt, then pull quickly to start the engine. Return cord gently into the recoil starter. Never allow the cord to snap back.
6. If engine fails to start, repeat step 4. NOTE: After repeated failed attempts to start the engine, please consult the troubleshooting guide before attempting again. If problems persist, please call customer service.
7. Once the engine has started, slowly return the choke lever all the way to the “OPEN” position.
8. Allow the engine to run for several minutes before cleaning snow. This allows the engine to stabilize its speed and temperature.

## **ELECTRIC START THE ENGINE**

To start the engine using the electric start function, perform the following steps:

1. Check the oil and gas levels.
2. Move the choke lever to the “CLOSE” position.
3. Make sure insert the switch key.
4. Press the primer bulb 3 times.
5. Plug the power cord to starting motor.
6. Press the start button for 2-3 seconds or until the engine starts. NOTE: If the engine does not start after 2-3 seconds, release the start button.
7. If engine fails to start, wait 10 seconds, then repeat step 6. NOTE: After repeated attempts to start the engine, please consult the troubleshooting guide before attempting again. If problems persist please call customer service.
8. Once the engine has started. Slowly move the choke lever all the way to the “OPEN” position. Allow the engine to run for several minutes before attempting to clean snow.

## **CLEARING SNOW**

Start the engine once your snow thrower has been running outside for several minutes, it is now ready for use. Make sure the path in front of your Snow Thrower is free from people, animals, objects, and all other obstructions except for snow.

Adjust the chute outlet to the desired direction.

Turn the chute rotation handle clockwise or counter-clockwise until the desired position is reached.

**WARNING!** Never direct the chute outlet toward people or animals. While snow may seem harmless, it can contain rocks or other debris that can cause serious injury when projected through the chute.

1. Engage/depress the auger control lever (handle) to start the augers and impeller turning.
2. Set the desired direction and speed using the speed/gear control lever.

3. Engage/depress the drive control lever (handle) and direct the snow thrower into the snow to be cleared.

**NOTICE:** NEVER change speed/gear positions while the drive control lever (handle) is engaged.

Disengage the drive control handle BEFORE changing speeds or directions. If the snow is deeper than the height of the auger, remove it in several steps taking narrower swaths. Make several passes with the auger overlapping the cleared areas and reduce forward speed.

For the best clearing efficiency, clear snow before it melts, refreezes and hardens. Hard packed and wet snow can be very difficult to clear.

Clearing wet heavy snow can be a challenge, depending on ambient temperature, humidity levels, and overall climate conditions including actual snow conditions, there may be no 100% solution as snow may be too wet or compacted to move or throw. Wet snow will tend to clog and stick more to the augers and chute. Keep the auger engaged as much as possible when clearing wet snow to help prevent clogging.

**WARNING!** If snow is filled with foreign material, damage to the snow thrower may result. Avoid snow with foreign materials.

## **STOPPING**

When finished using your snow thrower, perform the following steps to shut it down.

1. Engage the auger and impeller for 30 seconds to clear any remaining snow inside your snow thrower.
2. Stop the auger blade rotation by releasing the (left) auger control lever (handle).
3. Remove Engine Safety Switch Key to stop engine operation.
4. Remove snow from all snow thrower surfaces including the auger housing and chute areas.

## **CLEARING RESTRICTIONS**

If the snow discharge chute or auger housing becomes clogged STOP the engine, Remove the Engine Safety key and make sure that all rotating parts have come to a complete stop. Use the supplied snow clean out tool to clear the obstruction. After unclogging, wipe the tool clean, and place it in the holder on top of the auger housing.

## **MAINTENANCE**

**WARNING!** Never perform maintenance while your snow thrower is running. Turn OFF the engine by removing the switch key before performing any maintenance tasks on your Snow Thrower.

Proper maintenance of your snow thrower will help prolong its life. Please perform the following maintenance procedures as required.

Do not attempt to repair your snow thrower unless you have the proper tools and instructions for disassembly and repair.

Check the bolts at frequent intervals for proper tightness to ensure that the equipment is in safe working condition.

After each snow removal session, run the snow thrower for a few minutes to prevent the auger/impeller system from freezing. Stop the engine, wait for all revolving parts to stop completely, and wipe residual ice and snow off the unit. Rotate the chute rotation handle several times to remove any excess snow.

## MAINTENANCE PROCEDURES

### TIRE INFLATION

Before each use of your Snow Thrower, check the tire pressure. The pressure in each tire should be in the range of 20-24 psi for the best performance. The pressure can be checked using an ordinary tire pressure gauge. Fill the tires using a small or pressure regulated air compressor.

**WARNING! DO NOT OVER-INFLATE THE TIRES.** Over-inflating could cause a tire to burst and cause severe bodily injury.

### SHAVE PLATE REPLACEMENT

Remove both skid shoes and hardware including carriage bolts and nuts which attach shave plate to snow thrower housing. Reassemble new shave plate, making sure heads of the carriage bolts are to the inside of the auger housing.

### AUGER OR IMPELLER JAMS

**WARNING!** The auger and impeller rotate at fast speeds which can cause harm or even amputation to a person's body parts. Even if you do not see the auger or impeller rotating, it may start at any time if the engine is running. Remove the Safety Key before cleaning the jams. The chute clean-out tool is fastened to the upper tube with mounting clips.

1. Always turn OFF the engine before attempting to clear any clogs or jams.
2. Keep hands and feet away from rotating parts while the engine is running.
3. Do not wear loose fitting clothing that can become entangled in rotating parts.
4. Wait until the auger and impeller have come to a full stop.
5. Clear any visible jams using the clean out tool attached to your machine.

**WARNING! DO NOT** try to clear jams with your hands or feet.



### AUGER SHEAR PINS REPLACEMENT

Shear pins are used to attach the auger shaft to the auger blades. Stop the engine by removing the safety key. A clog or jam in the augers may cause one or multiple shear pins to break. The shear pins are a safety mechanism and designed to break under high load or impact and protect the auger drive system from damage.

Replacement shear pins and nylon locknuts are provided with your snow thrower.

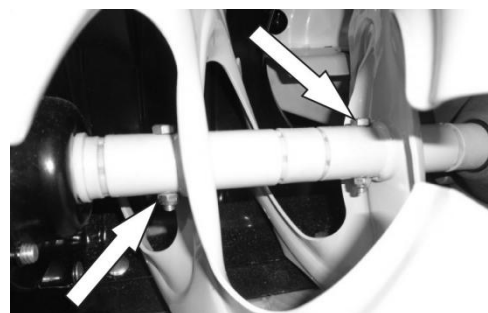

For additional replacement shear pins, please call the customer service department at (800)791 9458.

1. Turn off the engine and wait for all moving parts to come to a complete stop. Remove any remnants of the broken shear pin. It may be necessary to unscrew the nut from the broken shear pin and drive out the broken pin.
2. Insert a new shear pin through the hole in the auger shaft and tighten using the shear pin nylon locknut. Do not over-tighten the nylon locknut.

**NOTICE:** Never replace the shear pins with standard pins or fasteners. Damage may occur to the snow blower and drive systems.

### **DRIVE SPEED CONTROL ADJUSTMENT**

The speed/gear control lever is connected to connection rod that work in tandem to control machine speed and direction.

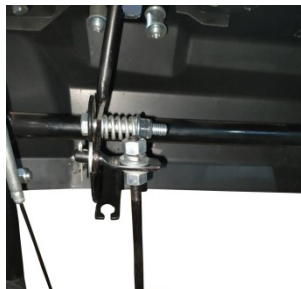
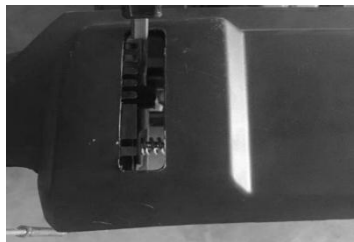

Lower Nuts

Depending on if the connection rod setting towards forward or reverse, adjustment of the connection rod will vary.

To adjust the connection rod, two nuts should be moved up and down until there is a positive direction change when the lever is shifted between F1 and R1. The middle position between these two settings is neutral (there is no actual neutral "notched" position on the control panel).

1. With the engine running engage the drive control handle and move the speed control lever between 1 and R1 to determine which way the connection rod need to be adjusted. Release the drive control handle when shifting between gears.
2. Loosen the jam nuts on connection rod (only one or two threads) and move upper and down nuts as required until a positive direction change is achieved when the lever is shifted between F1 and R1. This may take multiple attempts to find the exact setting.
3. Tighten the cable jam nuts once the proper setting has been achieved.

### **AUGER BELT REMOVAL**

**WARNING!** Entanglement Hazard – Before performing any service procedures, make sure the engine is off and remove the spark plug wire from the spark plug to ensure the engine cannot accidentally start.

Note: Record component position before disassembly, to assist in reassembly.

1. Disconnect the upper cable from the auger control handle.
2. Remove (Qty. 2) hex screws and remove belt cover.



- Loosen the belt guide pin hex screw (installed on engine crankcase) and rotate the pin away from the pulley.



Step 1

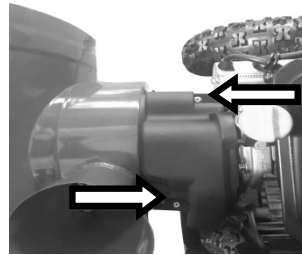

Step 2



Step 3

- Left Side - Loosen the hex nuts attaching the auger housing to the main frame.
- Right Side - Remove the hex nuts, lock washers and flat washers attaching the auger housing to the main frame.
- Remove the belt from the drive pulley while pulling the right side of the auger housing away from the main frame just enough to access the belt and auger pulley.
- Push the auger tension pulley arm to move the auger brake, away from the belt to allow removal of the belt.
- Remove the auger belt.



Step 4

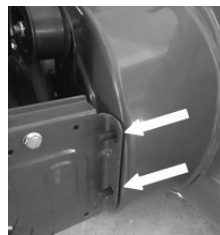

Step 5



Step 6



Step 7

## AUGER BELT INSTALLATION

**WARNING!** Entanglement Hazard – Before performing any service procedures, make sure the engine is off and remove the spark plug wire from the spark plug to ensure the engine cannot accidentally start.

- Push the auger tension pulley arm to move the auger brake to allow access for installation of the belt into the auger pulley.
- Route the belt to the inside of the tension pulley, auger brake and install the auger belt onto the drive pulley while pulling the auger housing into position with the main frame.
- Install and/or tighten the hex nuts attaching the auger housing to the main frame. Tighten all fasteners securely, do not over tighten.
- With the belt installed on both pulleys and tension pulley in position, move the belt guide pin to within 3/16 to 3/8 in. from the belt seated in the pulley and tighten the pin in position.



Step 1



Step 2



Step 4

Note: The belt guide pin helps keep the belt in the pulley when the belt is disengaged. The pin should not be tight to the belt. The pin should be loose enough to allow the belt to spin freely but not allow the belt to jump off the pulley.

5. Connect the upper cable to the auger control handle.
6. Install belt cover using (Qty. 2) hex screws.

**WARNING!** Ensure the belt cover is installed and all safety guards are in place before the engine is started and at all times when the engine or machine are operating.

## **AUGER BELT AND RELATED COMPONENT INSPECTION**

When replacing your snow blower auger belt, it is important to determine the cause of the failure (if applicable) and take corrective action to avoid repeated failure.

Inspect the belt:

- Correct size and type
- Missing pieces
- Burning
- General damage
- Fraying or peeling apart
- Cracks and tears
- Uneven wear patterns
- Foreign material on belt, oil, grease, dirt etc.

Inspect the auger pulleys:

- Broken sheave or hub
- Loose or missing mounting bolts
- Bent or "out-of-round" condition (pulley doesn't spin true)
- Misaligned pulleys
- Foreign material on pulleys, oil, grease, dirt, etc.
- Misaligned tension pulley
- Tension pulley loose or damaged
- Tension pulley and arm assembly operation
- Does the tension arm move freely both engaged and disengaged directions without binding?
- Misaligned tension pulley, the pulley should move parallel to the belt centered to the belt
- Check return spring operation and tension

Inspect the auger control lever (handle) and cable:

- Cable and connection damage
- Free movement (from engage to disengaged positions)
- Binding or improperly routed cable
- Cable pulley(s) damage, misalignment and binding
- Cable adjustment plate damaged or improper installation
- Handle damaged or binding at pivot

## **STORAGE & CLEANING**

### **PROPER STORAGE PROCEDURES**

**WARNING!** Never store your snow shrower for extended periods of time with fuel in the tank or carburetor. Fuel stabilizer can be added to the fuel in can to extend its shelf life for storage.

Store the unit in a locked, dry place out of the reach of children to prevent unauthorized use or damage. Cover loosely with a tarp for added protection.

### **CLEANING**

1. To clean your Snow Thrower, use a damp cloth and mild detergent on the surfaces only. Never get soap or water inside the working mechanisms of your Snow Thrower.

Note: Do not clean with water. Water will freeze due to low temperature and damage the machine.

2. Clean the Snow Thrower of snow and ice buildup before storing or transporting. Be sure to secure the unit while transporting.
3. Inspect the Snow Thrower carefully for worn, loose, or damaged parts. Check connections and screws and tighten if necessary.

# TROUBLESHOOTING

Problem	Causes	Remedy
<p>WARNING - Before attempting to make any inspections, repairs or adjustments, stop the engine, wait for all moving parts to stop moving and carefully disconnect the engine spark plug wire. If tipping or turning the snow blower is required for any inspection or repair, first wait until the engine is cool to the touch and then drain the engine of all fuel and oil into suitable containers and store or dispose of in a proper manner.</p>		
<p>Engine Systems - Note: For all engine problems, see the below troubleshooting information.</p>		
Engine Fails to Start (Engine cranks over)	Spark plug wire disconnected	Connect wire to spark plug
	Faulty spark plug	Clean, adjust gap, or replace spark plug.
	Engine flooded with fuel	Discontinue choke or primer use, clean or replace spark plug.
	Safety key not inserted in engine ignition	Insert key fully into the switch
	Choke not in START position	Move choke to START position, after engine starts slowly move to RUN position as engine speed and operation stabilizes at the set rpm. If engine still does not start move to half choke and crank engine.
	Fuel incorrect, old or stale, will not ignite	Empty and clean fuel tank & carburetor, refill with fresh, clean gasoline. (Note: Fuel may become stale after 30 days in some cases)
	Blocked or clogged fuel system or line	Clean fuel system or line
Engine electric starter will not crank engine	Extension cord is not properly attached to electric starter terminal	Re-insert extension cord into electric starter terminal.
	No power from power supply, tripped breaker	Check power supply extension cord is attached to.
	Extension cord wire gauge is too small or cord is too long	Use proper rated and length extension cord
Engine runs erratic, stalls or seems low on power	CHOKE in ON or partial ON position	Move CHOKE lever to RUN
	Fuel incorrect, old or stale	Empty and clean fuel tank & carburetor, refill with fresh, clean gasoline. (Note: Fuel may become stale after 30 days in some cases)
	Blocked or clogged fuel system or line	Clean fuel system or line
	Carburetor is in need of cleaning	Clean fuel system and carburetor
	Spark plug wire loose	Connect and tighten spark plug wire
	Faulty spark plug	Clean, adjust gap, or replace spark plug, see Engine Operator's manual
	Engine oil over filled	Drain oil to proper level. Oil should not be above the top 2 threads of LOWER fill plug.
Engine oil level low or empty	Add oil	

Problem	Causes	Remedy
<b>Drive system</b>		
No forward or reverse drive movement when drive handle engaged	Drive belt loose or damaged	Check drive belt tension pulley for damage or incorrect tension, repair as necessary. Replace drive belt.
	Friction drive wheel is worn or damaged	Replace friction drive wheel
	Friction drive wheel wet or slipping	Allow snow blower to dry and or warm up or adjust drive cable tension as necessary
	Wheel to axle pins broken or missing	Replace pins attaching wheels to axle
Drive speed control stuck in gear or won't change gears	Speed control lever loose or damaged, not moving speed control cables	Check speed control lever and cables for damage or loose or missing parts. Repair or replace parts as needed, ensure pivot stud spring tension is correct, adjust pivot nut spring tension as needed.
	Speed control cables loose, damaged or binding	Repair, adjust or replace as necessary
Drive speed control allows only 1 direction	Speed control cables misadjusted, loose, damaged or binding	Check speed control lever and cables for damage or loose or missing parts. Repair or replace parts as needed. Adjust drive speed control cables, see Drive Speed Control Cables Adjustment
Drive engaged when drive control handle released	Drive control cable binding, won't release	Repair, replace cable as necessary
	Friction drive wheel return spring broke or missing	Replace spring, adjust cable as necessary
<b>Auger System</b>		
Auger not rotating when auger control handle engaged or Not blowing snow or Poor snow blowing performance	Chute assembly clogged	Clean chute and inside of auger housing with clean-out tool
	Auger shear pins broken	Replace shear pins. Check each auger blade shear pin.
	Foreign object in auger or impeller causing auger to stop without shearing pins	Remove object from auger or impeller areas
	Auger belt loose, slipping, worn or damaged	Replace auger belt
	Auger belt tension cable loose, damaged or binding	Repair, adjust or replace as necessary
	Auger blade(s) damaged or bent	Replace auger blade(s)
	Auger gearbox mechanical damage, auger drive system not rotating freely (binding)	Check bearings, bushings and all system parts for damage or mechanical binding. Repair or replace as necessary using proper lubrication
	Impeller damaged	Replace impeller
	Impeller not connected to impeller shaft, impeller or shear pins broken	Replace shear pins or impeller as necessary
	Forward speed too fast while blowing snow, overload	Allow engine to maintain its speed.

Problem	Causes	Remedy
Auger System		
Auger belt broken, or repeated failure	Auger tension pulley arm return spring broken or missing	Replace tension arm return spring
	Auger tension pulley arm stuck or binding	Repair or replace tension arm as necessary
	Auger tension pulley arm or pulley misaligned or damaged	Repair, replace or align tension arm and or pulley as necessary
	Foreign material on pulleys and belt, oil, grease, dirt etc.	Clean belt and pulleys as necessary, replace belt if necessary
	Auger pulleys misaligned, loose, damaged or bent	Replace or align pulleys as necessary
	Incorrect or damaged auger belt	Replace with correct size and type belt
	Auger belt guide pin not adjusted	Adjust belt guide pin to within 1/8 to 3/16 in. from pulley. (Guide pin keeps belt in pulley when disengaged)
Auger rotating when auger control handle released	Auger tension pulley arm return spring broken or missing	Replace tension arm return spring

# EXPLODED VIEW AND PARTS LIST

## Panel Assembly

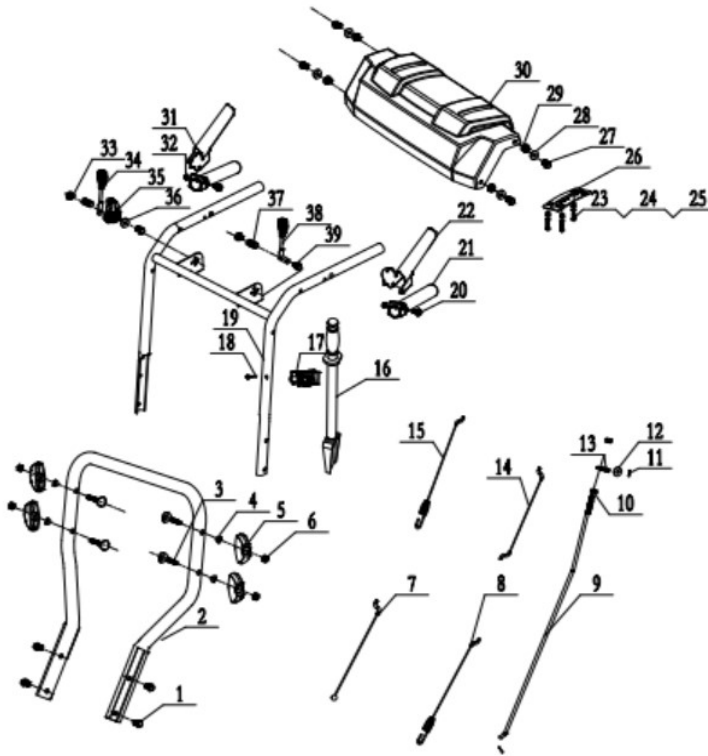

Item	Stock#	Description	Qty
1	303020498	Hex Flange Screw M8X18	4
2	303080555	Lower Handle	1
3	303020461	Washer $\Phi 8$	4
4	303043010	T-screw M8 $\times$ 55	4
5	203020336A	Knob	4
6	303030066	Nut M8	4
7	303200050	Lower Drive Cable	1
8	303200012	Lower Auger Cable	1
9	303071442	Speed Control Connection Rod	1
10	303030076	Flange Normal Nut M8	2
11	303160846	Dowel Pin $\phi 2$	2
12	303042023	Flat Washer $\phi 8 \times \phi 18 \times 2$	1
13	303123034	Connection Rod Pin $\Phi 7$	1
14	303200106	Upper Auger Cable	1
15	303200130	Upper Drive Cable	1
16	203050057	Clean Out Tool	1
17	203050512	Rocker Seat	1
18	303010164	Screw M6 $\times$ 20	1
19	303181160A	Upper Handle Welding	1
20	303020486	Hex Flange Bolt M6X50	2

Item	Stock#	Description	Qty
21	203070105	Handle Cover	2
22	303181183	Left Operation Trigger	1
23	303010193	Screw 6 $\times$ 16	3
24	303042042	Flat Washer $\phi 6 \times \phi 16 \times 2$	3
25	303160746	Cushion Cover	3
26	303071343	DB7109 Gear Plate	1
27	303020275	Hex Washer Bolt M8X40	4
28	303042013	Flat Washer $\phi 8 \times \phi 22 \times 2$	4
29	303030077	Flange Lock Nut M8	4
30	203050373	Panel	1
31	303071336	Right Operation Trigger	1
32	303030130	Flang Nut	2
33	303030077	Flang Lock Nut	2
34	203070085	Control Handle	1
35	203021099	Drive Cable Control Plate	1
36	203020380	Tooth Gasket	1
37	303130074	Spring	2
38	203070102	Control Handle	1
39	303020274	Hex Bolt M8X45	2

## Chute Assembly

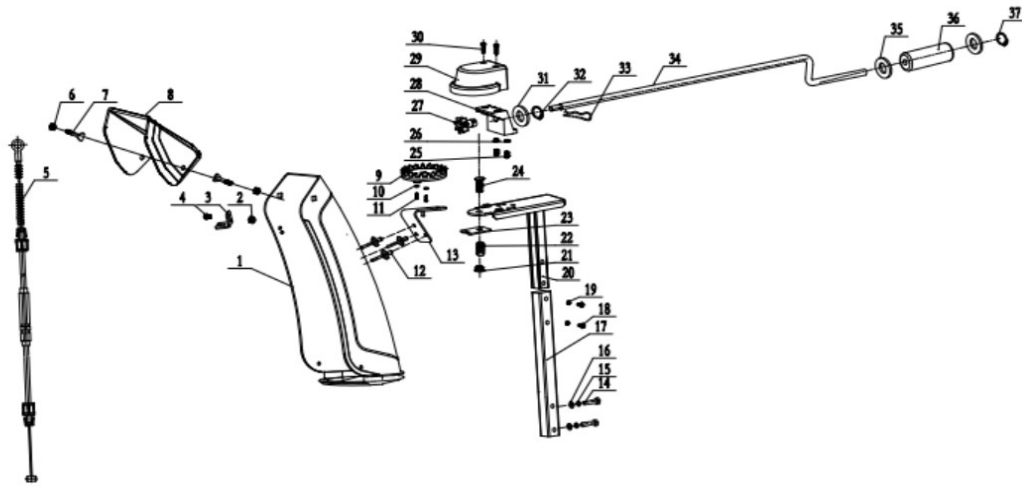

Item	Stock #	Description	Qty
1	203050514	Chute	1
2	303030087	Hex Flang Lock Nut M6	1
3	303071344	Cable Seat	1
4	303020244	Hex Flang Bolt M6×14	1
5	303200117	Chute Cable	1
6	303030077	Hex Flang Lock Nut M8	2
7	303020622	Bolt M8×20	2
8	203050515	Upper Chute	1
9	203021301	Chute Steering gear	1
10	303042019	Flat washer φ4×φ12×1	2
11	303010026	Screw 4X12	2
12	306110029	Rivet φ6×10	3
13	303071053	Steering Dead Plate	1
14	303020275	Hex Bolt M8×40mm	2
15	303041022	Spring Washer Φ8	2
16	303042023	Flat Washer φ8×φ18×2	2
17	303181010	Chute Support Tube Welding	1
18	303020503	Hex Flange Bolt M6×35	2
19	303030087	Hex Flange Lock Nut M6	2

Item	Stock #	Description	Qty
20	303181164	Small Support Tube Welded	1
21	303030077	Locknut M8	1
22	303130325	Pressure Spring φ3	1
23	303071056	Locating Plate	1
24	303020165	Square Bolt M8X55	1
25	303020246	Bolt M6X16	2
26	303030032	Locknut M6	2
27	303060131A	Steering Pinion	1
28	203010818	Steering Gear Seat	1
29	203010817	Steering Gear Cover	1
30	303010026	Screw 4X12	2
31	303043058	Flat Washer φ13.5×φ24×2	1
32	303050044	Shaft Ring φ13	1
33	303160845	Dowel Pin φ2.5	1
34	303160755A	Z-long Rocker	1
35	303042004	Flat Washer φ10×φ22×2	2
36	203020371	Rocker Lever	1
37	303050029	Shaft Ring φ10	1



# Frame Assembly

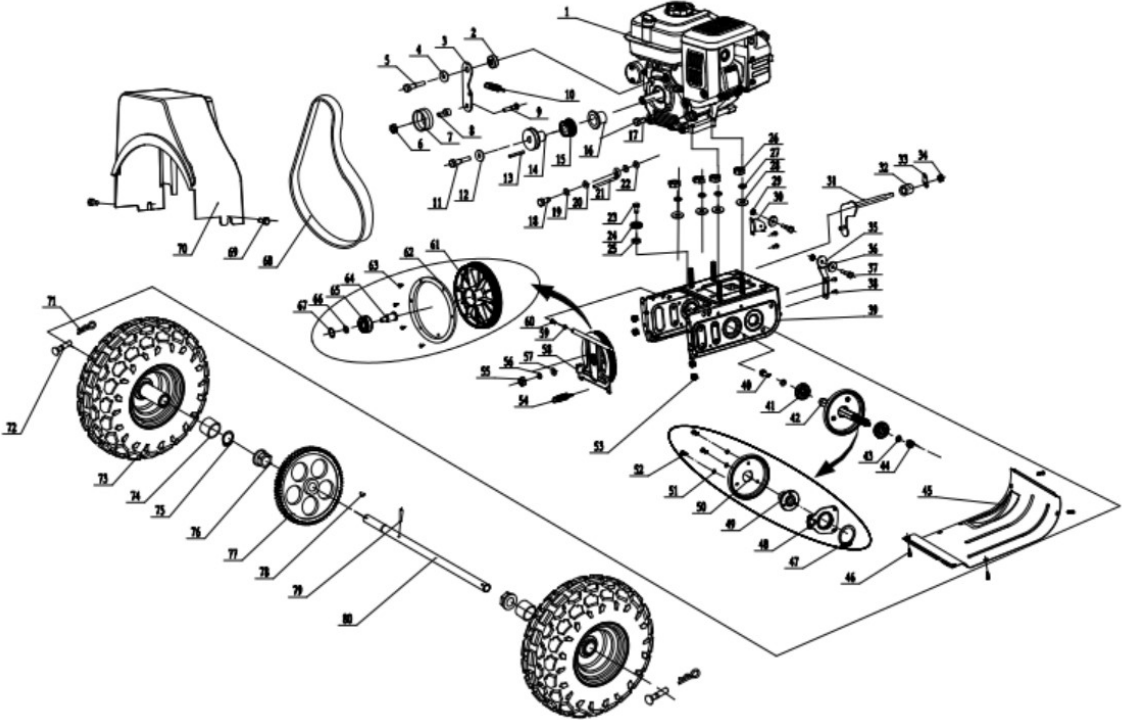

Item	Stock #	Description	Qty
1	9999960501	Engine 212CC	1
2	303160192	Small Tensioning Plate Spacer	1
3	303070202	Small Tensioning Plate	1
4	303042005	Flat Washer $\phi 8 \times \phi 28 \times 3$	1
5	303020279	Outer Hex Flange Bolt M8x25	1
6	303030077	Flange Locknut M8	1
7	203100004	Tension Wheel Assembly	1
8	303160195A	Bushing	1
9	303020154	Step Bolt M8x40	1
10	303130094	Friction Wheel Bracket Spring	1
11	303020124	Flange Hex Bolt M8x35	1
12	303042005	Flat Washer $\phi 8 \times \phi 28 \times 3$	1
13	Loncin BYO	Flat key 4.7x70	1
14	303160152A	V-belt Wheel	1
15	303060041	Synchronous Pulley Wheel	1
16	303060040	Adjustable Pad	1
17	303160432	Screw	1
18	303020279	Hex Bolt M8X20	1
19	303041022	Spring Washer $\Phi 8$	1
20	303042023	Flat Washer $\phi 8 \times \phi 18 \times 2$	2
21	303080145	Belt Stop Lever $\phi 6$	1
22	303043016	External Teeth Lock Washer $\Phi 8$	1
23	303160177	Guide Pulley Screw M6	1
24	203020364	Guide Pulley	1
25	303030032	Locknut M6	1
26	303030066	Nut M8	4
27	303041022	Spring Washer $\Phi 8$	4
28	303042023	Flat Washer $\phi 8 \times \phi 18 \times 2$	4
29	303030032	Locknut M6	2
30	303070418A	Guide Wheel Plate	1
31	303181227	Gear Shift Fork Welded	1
32	303160308	Friction Wheel Support Shaft Sleeve Tube	1
33	303160830	Shift Pick	1
34	303030077	Flange Lock Nut M8	1
35	303071243	Guide wheel plate	1
36	203020364	Guide Pulley	2
37	303160177	Guide Pulley Screw M6X35	2
38	303020444	Flange Hex Bolt M6X12	4
39	303181006	Frame Welded	1
40	303020239	Hex Flang Bolt M10X20	1

Item	Stock #	Description	Qty
41	303100051	Grooved Deep Groove Ball Bearing	2
42	303160799	Six Square Axis	1
43	303042004	Flat Wsher $\Phi 10 \times \Phi 22 \times 2$	2
44	303343043	Locknut M10	1
45	303525287	Big Bottom Plate	1
46	303586035	Triangular Head Bolt	4
47	303050027	Shaft Ring $\Phi 30$	1
48	303210036	Fork Riveting	1
49	303160803	Six Square Sleeve	1
50	202170009	Friction Wheel Assembly	1
51	303041009	Spring Washer $\Phi 6$	3
52	303020244	Hex Flang Bolt M6x14	3
53	303030077	Hex Flang Nut	4
54	303130094	Friction Wheel Bracket Spring	1
55	304315011	Serrated Nut	1
56	304375759	Elastic Washer	1
57	303042004	Flat Washer	1
58	303181163	Friction Wheel Support Welding	1
59	304132767	Flat Washer	1
60	303020244	Outer Hex Flange Bolt M6x14	1
61	303160801	Large Synchronous Belt Pulley	1
62	304618751	Rim	1
63	304679499	Screw M6x10	6
64	303160802	Large Synchronous Belt Shaft	1
65	304800995	Deep Groove Ball Bearing 6203Z	1
66	303042169	Flat Washer $\phi 17 \times \phi 24 \times 3$	1
67	303050519	Ring $\Phi 40$	1
68	302040078	Synchronous belt	1
69	304922491	Flange bolt M6X12	2
70	203050335	Belt cover	1
71	303160845	Dowel Pin 1 $\phi 2.5$	2
72	303160815	Dowel Pin 2 $\Phi 6$	2
73	302090217	13" Wheel Assembly	2
74	305165483	Spacer Bush	2
75	305226231	Shaft Ring $\Phi 19$	1
76	305286979	Bushing	2
77	305347727	Big Gear	1
78	305408475	Woodruff Key 5x7.5x19	1
79	305469223	Elastic cylindrical pin 5x30	1
80	305529971	Axle	1

Auger Housing Assembly

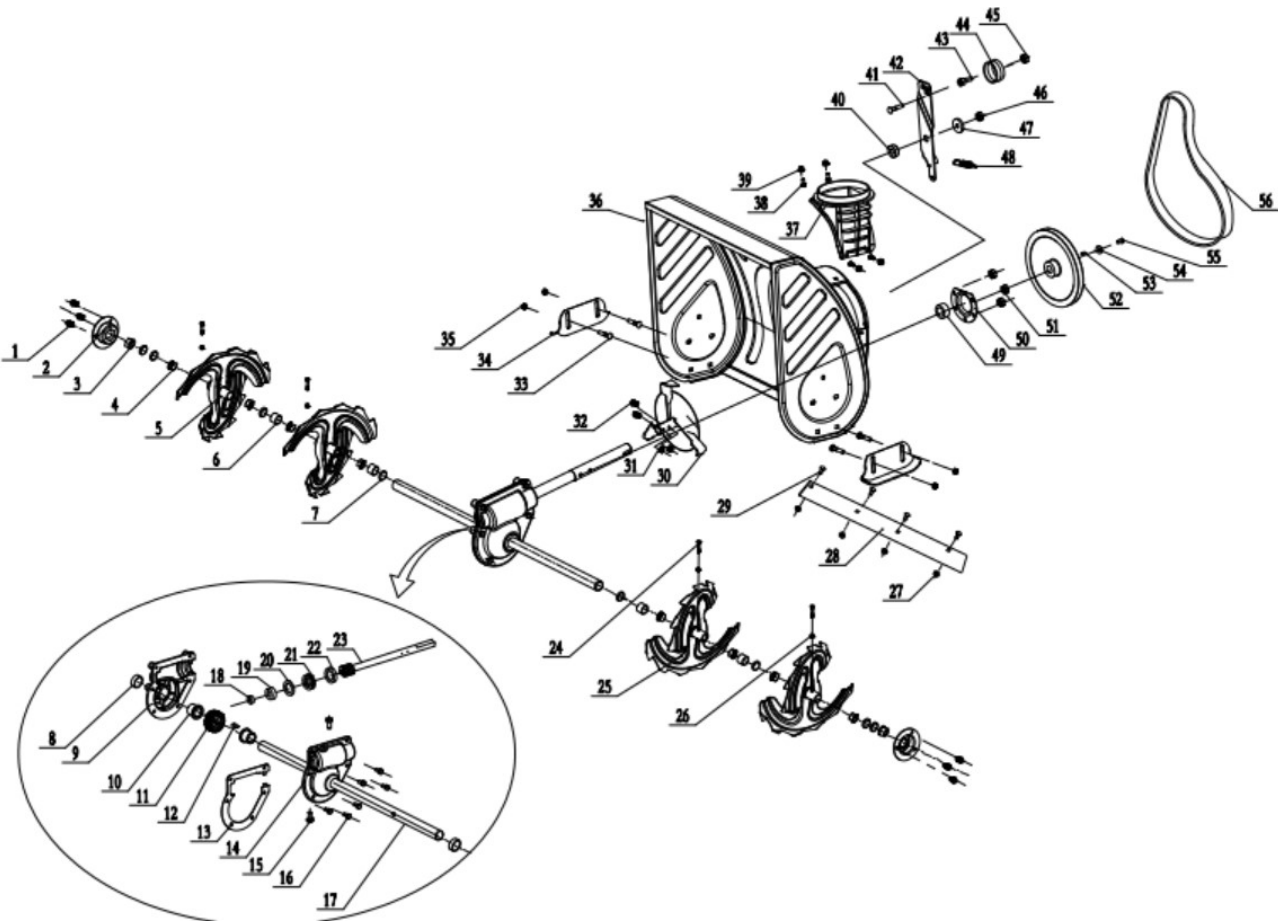

Item	Stock#	Description	Qty
1	303020245	Hex Flange Bolt M8X14	6
2	303070234	Bearing Block	2
3	203060013	Plastic Bearing	2
4	203060012	Auger Sleeve	8
5	303180409	Right Auger Welding	2
6	203050108	Spacer Bush 1	4
7	203050109	Spacer Bush 2	8
8	302130005	Skeleton seal $\phi 19 \times \phi 32 \times 7$	2
9	303090032	Worm gear Box Left	1
10	303060055	Worm Gear Shaft Sleeve	2
11	303090033	Worm Gear	1
12	303110022	Woodruff Key	1
13	303070260	Worm Gear Shaft Sleeve	1
14	303090031	Worm gear Box Right	1
15	303020142	Bolt M8x10	2
16	303020489	M6x18	6
17	303160370	Auger Axle	1
18	303100030	Deep groove ball bearing 6001Z	1
19	303100035	Deep groove ball bearing 6904Z	1
20	303070179	Worm Box Washer	1
21	303100039	Bearing 51104	1
22	302130002	Skeleton seal $\phi 20 \times \phi 35 \times 7$	1
23	303160314	Worm	1
24	303160355	Shear Pin	4
25	303180410	Auger Welding Left	2
26	303030032	Lock Nut M6	4
27	303030076	Flang Normal Nut M8	4
28	303071330	24" Shave	1

Item	Stock#	Description	Qty
29	303020332	Bolt M8x14	4
30	303181158	Impeller	1
31	303030032	Lock Nut M6	2
32	303020442	Hex Washer Bolt $\phi 6 \times 35$	2
33	303020166	Bolt M8x18	4
34	303070197	Skid Shoes	2
35	303030077	Flang Lock Nut M8	4
36	303181159	Auger Housing Welding	1
37	203050511	Lower chute seat	1
38	303020341	Bolt M6x16	4
39	303030087	Flange Lock Nut M6	4
40	303160192	Small Tensioning Plate Spacer	1
41	303020154	Bolt M8x40	1
42	303071345	Big Tension Plate	1
43	303160195A	Tensioning Wheel Casing	1
44	203100003	Tensioning Wheel Assembly	1
45	303030077	Flange Lock Nut M8	1
46	303030059	Lock Nut M10	1
47	303042078	Flat Washer $\phi 10 \times \phi 30 \times 2$	3
48	303160175	Large Tensioning Plate Tension Spring	1
49	303100040	Bearing	1
50	303070233	Bearing Plate	1
51	303030077	Flang M8	3
52	303160794A	7109 Big Pulley	1
53	303110014	Flat Key C6X18	1
54	303042005	Flat Washer $\phi 8 \times \phi 28 \times 3$	1
55	303020279	Hex Washer M8x20	1
56	302040079	V-Belt 720mm,4LXA	1

# Engine Explode View and Bom List

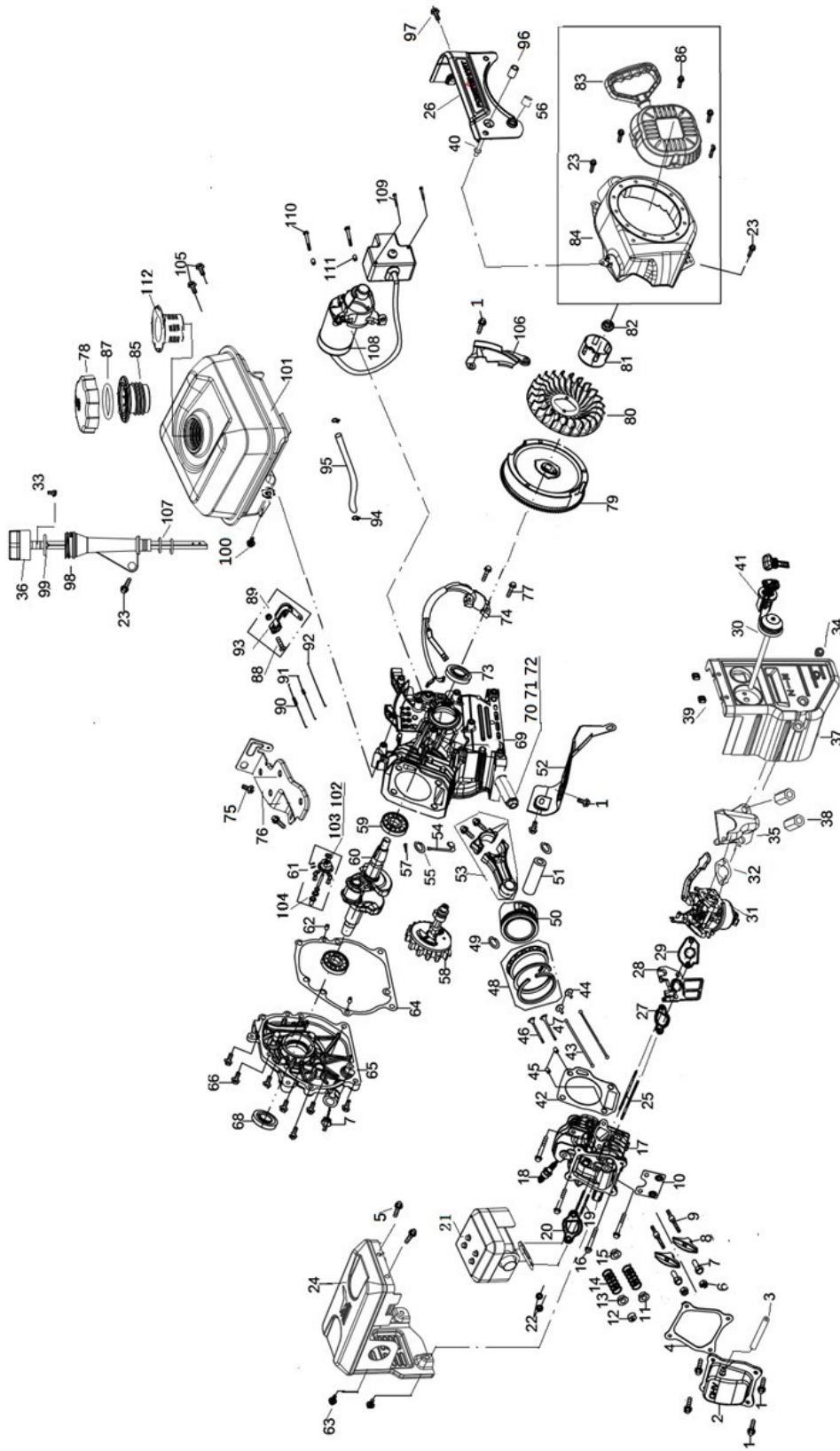

Item	Stock#	Description	Qty
1	303020444	Hexagon Head Flange Bolt M6X12	7
2	9020960102	Breathing cover	1
3	9051960302	muffler pipe	1
4	9245960103	Cylinder Head Cover Gasket	1
5	303020382	Screw M6X12	2
6	9143960101	Air lock nut	2
7	9143960102	Valve clearance adjusting nut	2
8	9230960101	Valve rocker	2
9	9142960101	Rocker seat locating bolt	2
10	9220960101	Push rod guide plate	1
11	9170960102	Intake valve spring seat	1
12	9402960101	Exhaust valve adjusting cap	1
13	9170960103	Exhaust valve spring seat	1
14	9531960101	Valve spring	2
15	9245960101	Oil shield assembly	1
16	303020620	Bolt M8X60	4
17	9020960101	Cylinder head assembly	1
18	9566960301	Spark Plug	1
19	303010324	Muffler stud	2
20	9245960105	Muffler gasket	1
21	9569960301	Muffler assembly	1
22	303030111	Nut M8	2
23	303020382	Bolt M6X12	4
24	9569960302	Muffler housing	1
25	303010323	Carburetor stud	2
26	9225960302	Fuel tank panel	1
27	9245960107	Seal gasket	1
28	9535960101	Thermal baffle	1
29	9245960108	Seal gasket	1
30	9532960301	Primer pump assembly	1
31	9568960501	carburetor assy	1
32	9245960102	Empty filter washer	1
33	303010095	Self tapping screw ST4X14	1
34	303020382	Bolt M6X12	2
35	9170960101	Empty filter holder	1
36	9198960102	High oil ruler cover	1
37	9225960301	Switch panel	1
38	303020514	Hexagon nut	2
39	303030136	Square nut	2
40	303030135	Stud	2
41	9440960102	Key switch assembly	1
42	9245960204	Cylinder head gasket	1
43	9013960101	Push Rod	2
44	9536960101	Valve lifter	2

Item	Stock#	Description	Qty
57	9534960101	Split cotter	1
58	9158960301	Camshaft assembly	1
59	9158960501	Bearing	2
60	9122960501	Crankshaft assembly	1
61	9438960101	Speed regulating driven gear combination	1
62	9140960103	Location pin	1
63	303020382	Bolt M6X12	2
64	9245960106	Case gasket	1
65	9563960102	Left crankcase cover	1
66	303020509	Bolt M8X32	6
67	9198960101	Oil lever gauge	1
68	9246960101	Oil seal	2
69	9563960101	Crankshaft box body	1
70	303020518	Drain bolt	1
71	303043042	Aluminum washer	1
72	303020508	Purge cock	1
73	9246960101	Oil Seal	1
74	9565960301	Igniter assembly	1
75	303020444	Hexagon head flange bolt	2
76	9228960301	Governor seat fixing plate	1
77	303020490	Bolt M6X25	2
78	9529960302	Fuel tank cap	1
79	9152960501	Flywheel components	1
80	9414960101	Fan	1
81	9194960101	Passive plate	1
82	303020511	Nut M14X1.5	1
83	9528960101	Starter assembly	1
84	9226960301	Wind scooper	1
85	9529960103	Oil tank screw cap	1
86	303020515	Bolt M6X8	4
87	9247960103	O ring	1
88	303020513	T-Bolt	1
89	303030112	Hexagon flange nut with teeth	1
90	9332960101	Speed regulating tension spring	1
91	9332960102	Throttle tension spring	1
92	9013960102	Choke putter	1
93	9230960101	Plunger arm	1
94	9533960201	Tubing clamp	2
95	9051960301	Oil Tube	1
96	9140960306	Bush	1
97	303020382	Bolt M6X12	1
98	9198960103	Oil ruler	1
99	9247960102	O-ring	1
100	303020382	Bolt M6X12	1

45	9140960102	Location pin	2
46	9113960102	Exhaust valve	1
47	9113960101	Intake valve	1
48	9564960501	Piston ring assembly	1
49	9146960501	Gudgeon pin circlip	2
50	9129960501	Piston	1
51	9140960501	Piston pin	1
52	9221960102	Fairwater	1
53	9015960501	Connecting rod	1
54	9005960101	Throttle governor handle	1
55	303043040	Washer	1
56	9140960106	Bush	6

101	9529960301	Fuel tank assembly	1
102	9121960101	Governing gear shaft	1
103	303043040	Washer	2
104	9092960101	Slide bushing	1
105	303020382	Bolt M6X12	2
106	9221960101	Flywheel side housing	1
107	9247960101	O-ring	1
108	9421960101	Starting motor assembly	1
109	303020517	Bolt M4X55	2
110	303020512	Bolt M6X30	2
111	9140960104	Locating pin	2
112	9115960101	Fuel filter	1

## TWO (2) YEARS LIMITED WARRANTY

PowerSmart is committed to building tools that are dependable for years. Our warranties are consistent with our commitment and dedication to quality.

### TWO (2) YEARS LIMITED WARRANTY OF POWER SMART PRODUCTS FOR HOME USE.

PowerSmart ("Seller") warrants to the original purchaser only, that all PowerSmart consumer power tools will be free from defects in material or workmanship for a period of two (2) years from date of purchase. Ninety (90) days for all PowerSmart Products, if the tool is used for professional or commercial use.

SELLER'S SOLE OBLIGATION AND YOUR EXCLUSIVE REMEDY under this Two (2) Years Limited Warranty and, to the extent permitted by law, any warranty or condition implied by law, shall be the repair or replacement of parts, without charge, which are defective in material or workmanship and which have not been misused, carelessly handled, or misrepaired by persons other than Seller or Authorized Service Center. To make a claim under this Limited Warranty, you must return the entire power tool product; transportation prepaid, to PowerSmart Include a legible copy of the original receipt, which lists the date of purchase (month and year) and the name of the company purchased from.

THIS LIMITED WARRANTY DOES NOT APPLY TO ANY ACCESSORY ITEMS INCLUDED WITH THE TOOL SUCH AS CIRCULAR SAW BLADES OTHER RELATED ITEMS OR TO ANY REPLACEMENT PARTS LISTED UNDER MAINTENANCE.

ANY IMPLIED WARRANTIES SHALL BE LIMITED IN DURATION TO TWO (2) YEARS FROM DATE OF PURCHASE. SOME STATES IN THE U.S. AND SOME CANADIAN PROVINCES DO NOT ALLOW LIMITATIONS ON HOW LONG AN IMPLIED WARRANTY LASTS, SO THE ABOVE LIMITATION MAY NOT APPLY TO YOU.

IN NO EVENT SHALL SELLER BE LIABLE FOR ANY INCIDENTAL OR CONSEQUENTIAL DAMAGES (INCLUDING BUT NOT LIMITED TO LIABILITY FOR LOSS OF PROFITS) ARISING FROM THE SALE OR USE OF THIS PRODUCT. SOME STATES IN THE U.S. AND SOME CANADIAN PROVINCES DO NOT ALLOW THE EXCLUSION OR LIMITATION OF INCIDENTAL OR CONSEQUENTIAL DAMAGES, SO THE ABOVE LIMITATION OR EXCLUSION MAY NOT APPLY TO YOU.

THIS LIMITED WARRANTY GIVES YOU SPECIFIC LEGAL RIGHTS, AND YOU MAY ALSO HAVE OTHER RIGHTS WHICH VARY FROM STATE TO STATE IN THE U.S., PROVINCE TO PROVINCE IN CANADA AND FROM COUNTRY TO COUNTRY.

For questions / comments, technical assistance or repair parts –  
Please call toll free at: 1-800-791-9458 (M-F 9am – 5pm EST)  
Email: [support@amerisuninc.com](mailto:support@amerisuninc.com)

SAVE YOUR RECEIPTS. THIS WARRANTY IS VOID WITHOUT THEM.



