

1. Scope

This product specification is applicable to lithium-manganese dioxide button batteries provided by Dongguan Shenneng Battery Technology Co., Ltd.

2. Applicable battery types:	Lithium-manganese dioxide button battery
3. Battery Type and Performance	
3.1 Model:	CR2032
3.2 Rated voltage:	3.0 V
3.3 Nominal capacity:	210mAh (load: 15.0 k, termination voltage 2.0 V)
3.4 Outline Dimensions:	As shown in the drawing
3.5 Standard Quality:	2.9 g
3.6 Shelf life:	1 year (temperature less than or equal to 25 °C and relative humidity less than 75%).
3.7 Appearance:	Visual inspection shows that the surface of the battery is smooth, free from damage and deformation, and the signs are clear.
3.8 Trademark Name:	"Lithium Battery, In the meantime, it is necessary to".
3.9 Manufacturing date and identification:	If necessary, the year and month of manufacture of the battery can be printed on the surface of the battery.

Example:

- 21 (manufactured in January 2012)
- 22 (manufactured in February 2012)
- 20 (manufactured in October 2012)
- 2Y (manufactured in November 2012)
- 2Z (manufactured in December 2012)

The following figure shows the code spraying pattern on the battery surface:

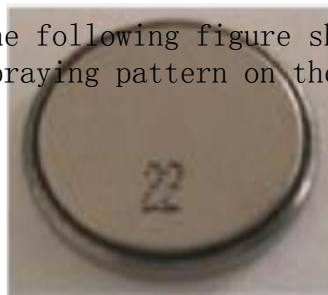

4;The lithium content: 59 mg

4. Main Technical Parameters (Table 1)

Project		Unit	Technical Indicators	Conditions
Nominal Voltage		V	3.0	CR series batteries only
Nominal capacity		MAh	210	Continuous discharge at 15.0 kload
Instantaneous short circuit current		MA	≥ 300	Time ≤ 0.5 ' ,
Open Circuit Voltage		V	3.25~3.45	All CR Series Batteries
Storage temperature		°C	0~40	All CR Series Batteries
Applicable temperature		°C	-20~60	All CR Series Batteries
Standard Weight		G	Approximately 2.9g	Only for this series of batteries
Self-discharge rate		%/year	≤ 2	Only for this series of batteries
Quick Test	Initial Period	H	≥ 66.7	At a load of 1.0 k and a temperature of 20 ± 2 °C, relative humidity $\leq 75\%$ RH Under the circumstances.
	12 months later	H	≥ 65.3	

Note 1: The electrochemical system and size of this product shall comply with IEC 60086-1: 2007 (i.e. GB/T8897.1-2008, original electricity

Pool, Part 1: General).

5. Product Specifications and Testing Methods

Unless otherwise specified, all tests of the product shall be carried out under the following conditions:

- (1) Ambient temperature: 20 ± 5 °C.
- (2) Relative humidity: $60\% \text{ RH} \pm 15\%$.

Table 2

Test Items	Test Method	Quality standard
1. Outline dimensions	Test and test with vernier caliper with accuracy not less than 0.02 mm Insulation materials should be pasted on the contact surface of calipers to prevent Short circuit.	Diameter (mm): 20.0 (-0.20) Height (mm): 3.20 (-0.20)
2. Open Circuit Voltage	Use numbers with accuracy not less than 0.25% and internal resistance greater than 1M Multimeter.	3.25~3.45 V
3. Instantaneous short circuit current	Test with pointer multimeter, each time for no more than 0.5', but it is necessary to avoid repeating the test and testing the time again. The interval should be more than 0.5 hours.	≥ 300 mA
4. Appearance	Purpose Measure	Clean and tidy, clearly marked, without deformation, Rust, leakage. Installed in-use device In the device, the two poles of the battery should always The ability to form and maintain good contact Yes.
5. Rapid discharge capacity	At standard temperature 20 ± 2 °C, relative humidity $\leq 75\%$ RH, negative When the load is 1.0 k and the termination voltage is 2.0 V.	≥ 66.7 hours
6. Vibration test	On a vibrating machine with a vibration frequency of 100-150 times per minute Continuous vibration for 1 hour.	Stable performance
7. Liquid leakage resistance at high temperature	Stored at 45 ± 2 °C for 30 days.	Leakage rate $\leq 1/10000$
8. Overdischarge leakage resistance Can	When the termination voltage reaches 2.0 V, the discharge is continuously discharged for 5 hours.	No leakage

Note 2: The overall dimensions and performance of this product comply with IEC 60086-2: 2007 (i.e. GB/T8897.2-2008, Primary Battery, Part 2: Requirements for overall dimensions and electrical properties).

Note 3:

1. The above tests have been confirmed by a large number of tests.
2. The company's standard is completely stricter than GB/T8897 "Primary Battery" standard promulgated by the state.
3. If the customer has special requirements, the company can adopt special testing methods according to the customer's requirements.

6. Discharge life

Load resistance	1 5 0 0 00hm
Discharge method (standard)	24-hour continuous discharge
Termination Voltage	2.0 V
Standard Time (Initial Period)	1000 hours
Standard time (after 12 months of storage)	980 hours

Initial test: The test carried out within one month after delivery.

Storage test: Under specific conditions, storage has been carried out after 12 months of testing.

7. Discharge characteristics on load

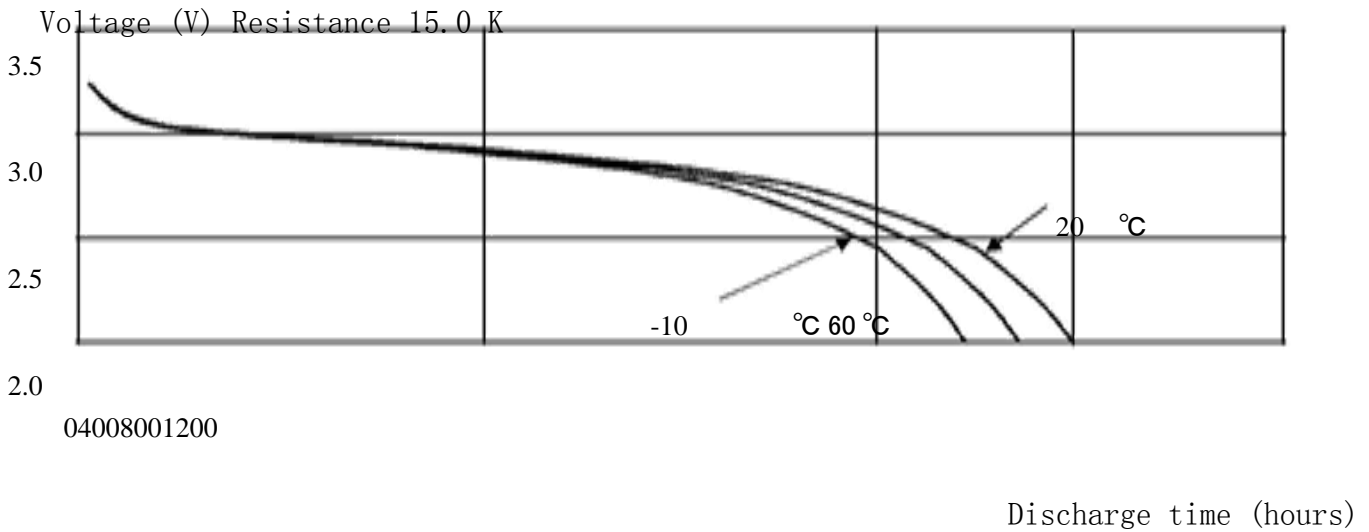

8. Battery Test

8.1 Temperature and humidity

8.1. 1 Test conditions

Unless otherwise specified, the test is generally carried out in an environment with a temperature of 20 ± 2 °C and a relative humidity of 65% RH \pm 20%. 8.1. 2 Storage conditions

Unless otherwise specified, the sample battery shall be stored in an environment with a temperature below 25 degrees and a relative humidity below 75% RH, and tested within one month of storage.

8.2 Testing Instruments, Instruments and Equipment

8.2. 1 Voltage shall be measured with a voltmeter in the area of 0V to 4V, with an accuracy of \pm 1 mV, or with a more accurate sum input

Multimeter test with input impedance exceeding 10M.

8.2. 2 The discharge load resistance will include the load of all external circuits with a tolerance not exceeding 0.5%.

8.2. 3 Outline dimensions will be measured using electronic digital display calipers with a distance of 0 to 150 mm and an accuracy of 5/100 mm or more accurate measuring tools.

8.3 Test Methods (or Procedures)

8.3. 1 Outline Dimensions

The measurement uses an electronic digital display caliper (refer to 8.2. 3).

8.3. 2 Appearance

Use visual inspection.

8.3. 3 Open Circuit Voltage

Use a voltmeter to measure the voltage (refer to 8.2. 1).

8.3. 4 Service life

After storing at normal temperature (20 ± 5 °C) for 12 hours, discharge continuously as shown in Table 1 until the termination voltage is 2.0 V

(Not suitable for this voltage), its service life will meet the requirements of Table 1.

8.3. 5 Leakage resistance inspection

Check the leak resistance. Under the condition of no cover, place it at a 40-watt fluorescent lamp 1 meter above and 30 cm away from the eyes to observe the smooth and clean surface of the battery without dirt.

9. Quality Assurance

(1) If it is confirmed that the product has defects in technology and materials, please replace the product with Dongguan Shenneng Battery Technology Co., Ltd. Free of charge. Please

Note that our company is only obliged to replace the battery. Other loss, damage, destruction, including indirect costs or expenses, directly caused or

Indirectly caused losses of any nature, such as products that have been used or cannot be used, are excluded.

(2) The battery must comply with the requirements of this specification when working. Otherwise, Dongguan Shenneng Battery Technology Co., Ltd. Cannot assume any responsibility, including (but not limited to) safety and customer claims, as well as losses, damages, actions or legal proceedings, costs (legal or other aspects) caused thereby.

(3) It is the customer's responsibility for the matching and reliability of batteries in actual settings or component applications.

(4) Dongguan Shenneng Battery Technology Co., Ltd. Will not be responsible for the following circumstances:

(I) Improper handling when using, installing or inspecting batteries.

(II) Failure to comply with the following instructions, precautions or warnings mentioned in this product specification.

(III) Failing to comply with the instructions and suggestions of Dongguan Shenneng Battery Technology Co., Ltd.

10. Other

Subject to RoHS instructions, this battery does not contain the following chemicals: lead, mercury, cadmium, hexavalent chromium, bromide, flame retardant, polybrominated biphenyl (PBB), polybrominated diphenyl ether (PBDE).

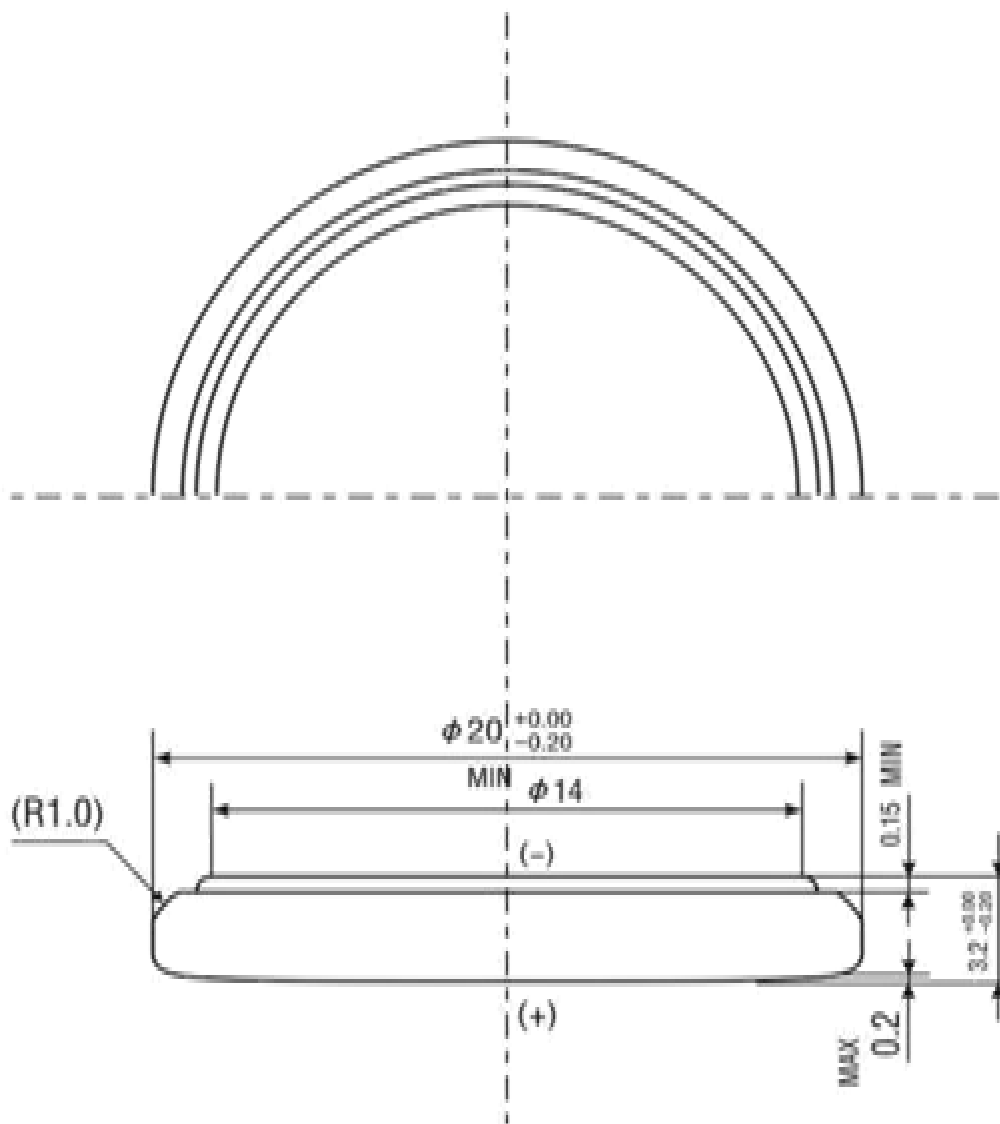

单位: mm

			设计	比例	型号
			 	5/1	CR2032
制图	史圆圆	2012.2.28	深能电池科技有限公司		深能工程图编号 SN18.2017.05-A
审核	朱敏飞	2012.2.29			
批准	解玉新	2012.2.29			



			设计	比例	型号	
					5/1	CR2032
制图	史圆圆	2012.2.28	深能电池科技有限公司		深能工程图编号 SN18.2017.05-A	
审核	朱敏飞	2012.2.29				
批准	解玉新	2012.2.29				

Usage and safety instructions

The battery consists of lithium, organic solvent and other flammable materials. Proper handling of batteries is crucial. Otherwise, the battery may cause deformation, liquid leakage (accidental leakage of liquid), overheating, explosion, fire, personal injury to others or damage to equipment. Please strictly follow the following instructions to avoid accidents.

Warning matter

- Do not swallow

In order to prevent children from easily taking in batteries and putting them in their mouths, batteries should be stored away from them. However, if all this

When it happens, you should take them to the hospital immediately.

- Non-rechargeable

The battery is not a rechargeable battery. You should not charge it because it may cause internal short circuit and gas generation.

Causing deformation, leakage, overheating, explosion, or fire.

- No heating

If the battery is heated above 100 degrees Celsius, it will increase the internal pressure, causing deformation, leakage, overheating, explosion, or fire. • No burning

If the battery is burned or exposed to flame, lithium metal will melt, causing explosion or fire.

- Do not disassemble the battery

Non-professionals are not allowed to disassemble batteries. Because it will cause sealing ring damage, deformation, leakage, overheating, explosion, or fire. • Avoid improper setup

Improper setting may lead to forced discharge of the battery. It may cause battery deformation, leakage, overheating, explosion, fire and other adverse consequences.

When set, the positive and negative terminals of the battery should not be connected backwards.

- No short-circuit battery

Direct connection between the positive and negative terminals of the battery should be avoided. If the metal items you carry or keep come into contact with the battery, the battery may

Deformation, leakage, overheating, explosion or fire occur.

- Do not solder batteries directly

Welding will cause the battery to increase heat, damage the sealing ring and melt lithium, damaging the battery. May lead to leakage, overheating, explosion or lead

A fire broke out. The battery should not be soldered directly to the equipment, it must be connected by connecting pieces or wires. The temperature of the soldering iron shall not exceed 50 centigrade.

The degree and welding time shall not exceed 5 seconds; It is important to keep the temperature low and the time short. When not soldering, do not put the battery in the soldering

In the pool, the soldering iron should not be placed on the battery. When welding, multiple welding should be avoided, because it is equivalent to the pair of
The battery is charged or shorted.

- Do not use different types of batteries

Different types of batteries must be avoided, because batteries produced by different manufacturers, of different types or with new and old combinations can

Can cause battery leakage, overheating, explosion, or fire. If it is necessary to use two or more batteries in series or in parallel. Recommendation

Obtained from Dongguan Shenneng Battery Technology Co., Ltd.

- Do not touch the leaking battery

If liquid leaks into your mouth, please rinse your mouth immediately. If liquid enters your eyes, you should rinse your eyes with water immediately.

In any case, you should go to the hospital to be treated by medical professionals.

- Keep the battery away from flammable liquids

If the battery leaks or smells strange smell, immediately keep the battery away from flammable liquid.

- Do not touch the battery directly

Try to avoid skin touching the battery directly, because this will cause skin injury.

Do not overlap and cross-stack batteries (as shown on the right)



If so, the battery may deform, leak, overheat, explode or fire.

- Warning processing

There are different regulations in different countries or regions, please abide by these regulations. In general, the battery (+) and (-) ends should be covered with insulating tape prior to disposal. This is because the waste battery still has capacity. When it comes into contact with other metals or metal materials, it can cause the battery to deform, leak, overheat or explode.

