

# ASSEMBLY

## Overview

- Remove packaging materials from snow blower.
- Rotate Handle into the upright position. Refer to Handle Assembly.
- Install the chute. Refer to Chute Assembly Options.
- Complete snow blower assembly according to model and equipment. Refer to Set-up.
- If necessary make adjustments to ensure proper snow blower operation. Refer to Adjustments.
- Add fuel and oil. Refer to the Engine Operator's Manual shipped with snow blower.

## Tools Required

- Adjustable Wrench or Socket Set
- Needle Nose Pliers

## Handle Assembly

1. Cut cable ties securing chute control rod or upper handle to the lower handle (if applicable), set aside the chute control rod (if applicable) and remove the wrap around the handles (if applicable).

**NOTE:** Do not cut the cable tie securing the control cables to the engine, if equipped.

**NOTE:** On models with Overhead Chute Control (with Flex Shaft), Four-Way Chute Control, and Electric Chute Control cut cable ties securing flex shaft to the lower handle and set the flex shaft aside. Remove rubber bands securing cables to carriage bolts and cut cable tie securing shift rod to lower handle. Refer to Figure 7 to help identify the control styles.

2. Loosen the top two nuts (a) securing the upper and lower handle and remove the two carriage bolts (b) from the upper handle and set aside as shown in Figure 1 or Figure 2 for models with side supports.

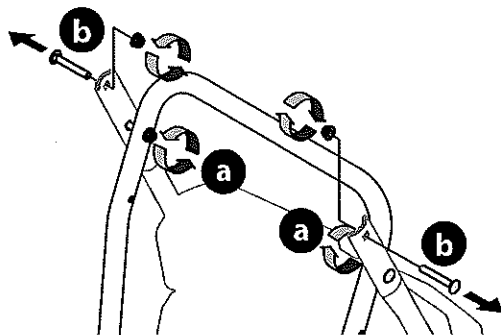

Figure 1

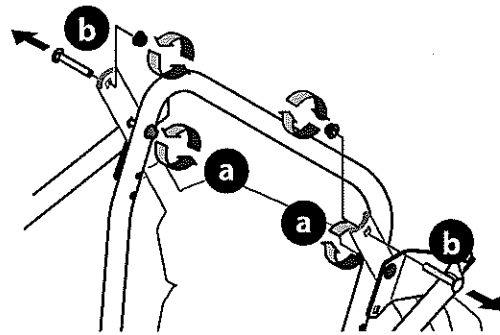

Figure 2

3. Place shift lever in Forward-6 position or fastest forward speed (if equipped).
4. Observe lower rear area of equipment to be sure both cables (if equipped) are aligned and seated properly in roller guides (Figure 3).

**NOTE:** On select models, chute-pitch control cables will be routed under the engine on the left side and will not use roller guides.

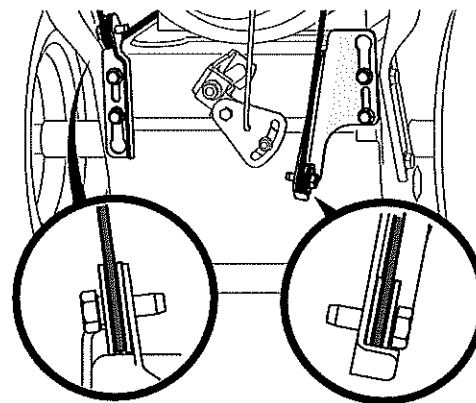

Figure 3

5. Pivot handle upward and align the lower handle (Figure 4). Remove and discard any rubber bands, if present. They are for packaging purposes only.

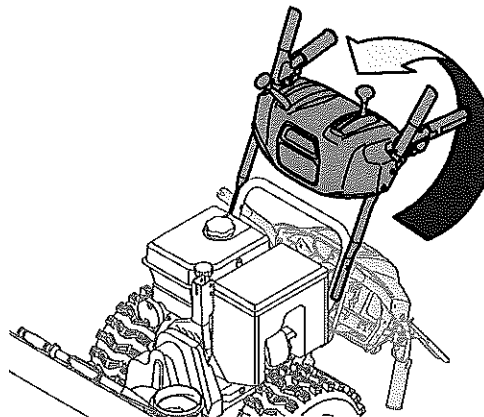

Figure 4

**NOTE:** On select models with steel rod speed selectors, you may need to lower shift rod to the side slightly to maneuver handle panel over it when pivoting handle upward.

# ASSEMBLY

6. Attach the two carriage bolts (b) and nuts (a) removed in Step 2. Finish securing the handle by tightening the top two nuts (c) loosened in Step 2. See Figure 5 or Figure 6 for models with side supports.

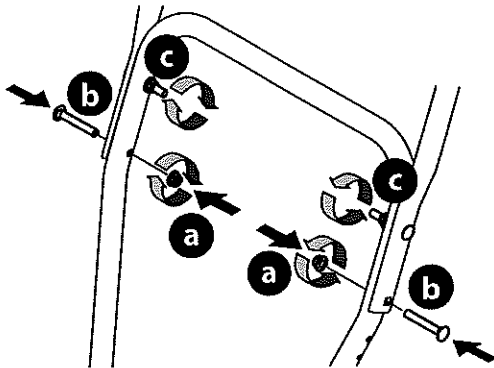

Figure 5

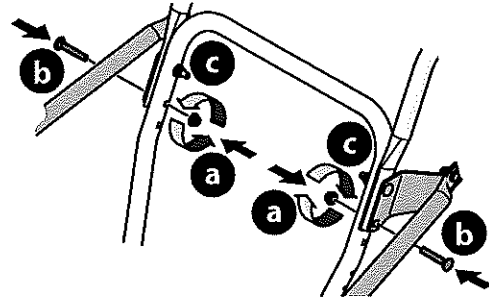
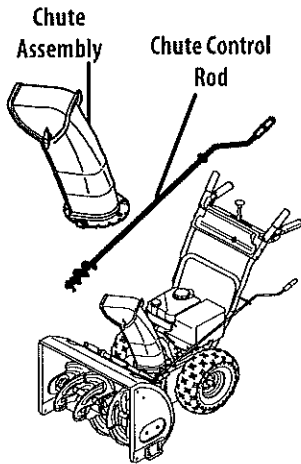

Figure 6

## STOP

Refer to Figure 7 below to identify your "Chute Control Style" and continue to the "Assembly" instructions for your specific style on pages 8-13.

### Chute Control Styles



Side Mounted Chute Rotation Control w/ Manual Pitch on page 8

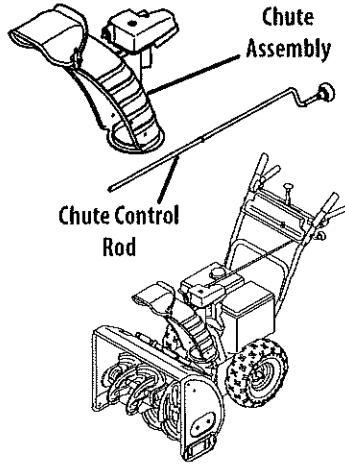

Overhead Chute Rotation Control w/ Manual Pitch on page 8

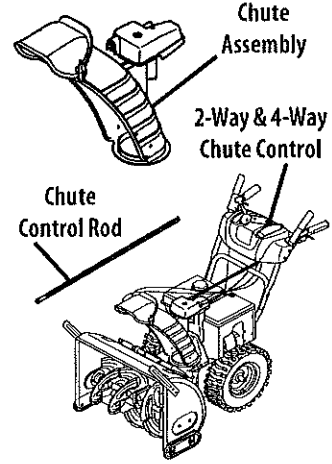

Overhead Chute Rotation Control w/ 2-Way Pitch or 4-Way Pitch & Rotation Control on page 9

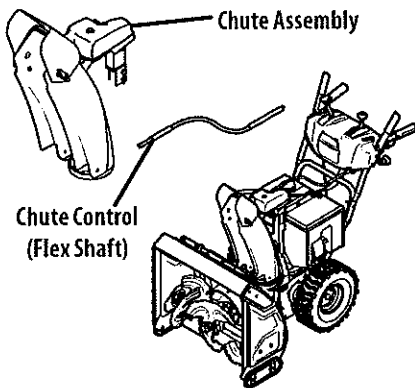

Overhead Chute Control (Flex Shaft) w/ Steel Chute & 2-Way Pitch Control on page 11

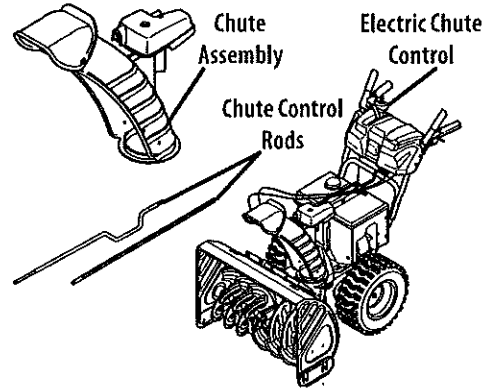

Overhead Chute Rotation Control w/ 4-Way Electric Pitch & Rotation Control on page 12

Figure 7

# ASSEMBLY

## Side Mounted Chute Rotation Control w/ Manual Pitch

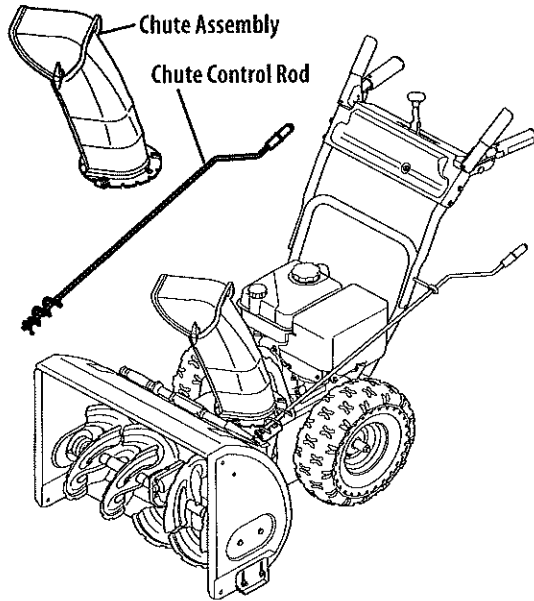

Figure 8

1. Position chute assembly over base (Figure 9).

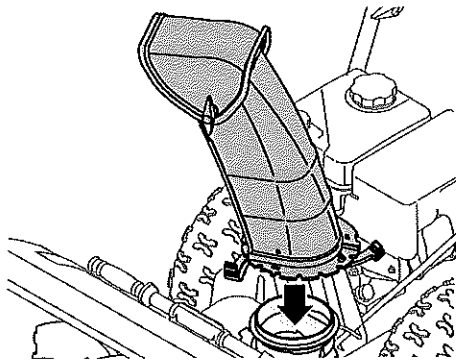

Figure 9

2. Close flange keepers to secure chute assembly to chute base. Flange keepers will click into place when properly secured (Figure 10).

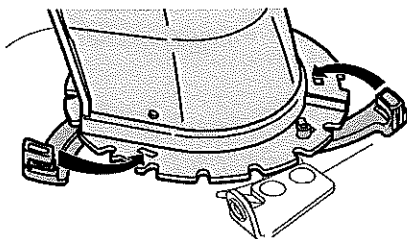

Figure 10

**NOTE:** Ensure the lower chute is secured to the flange on the chute base. The lower edge of the chute keeper should be positioned below the flange on the chute base after being clicked into place. If flange keepers will not easily click into place, use palm of your hand to apply swift, firm pressure to the back of the keepers.

3. Remove plastic cap (if present), flat washer (a) and hairpin clip (b) from end of chute control rod (Figure 11).

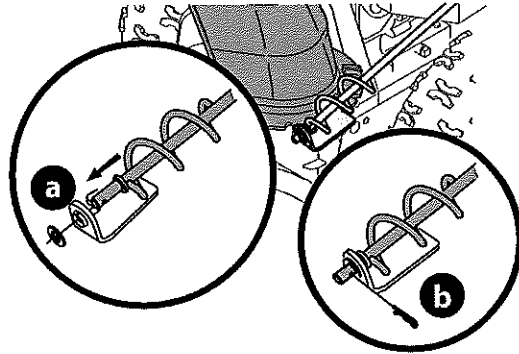

Figure 11

4. Insert end of chute control rod into lower bracket and secure with flat washer (a), hairpin clip (b) and plastic cap (if present) removed in Step 1. If necessary, lower bracket can be adjusted. Refer to Side Chute Control on page 16.

● STOP

Continue to Set-Up (page 14).

## Overhead Chute Rotation Control w/ Manual Pitch

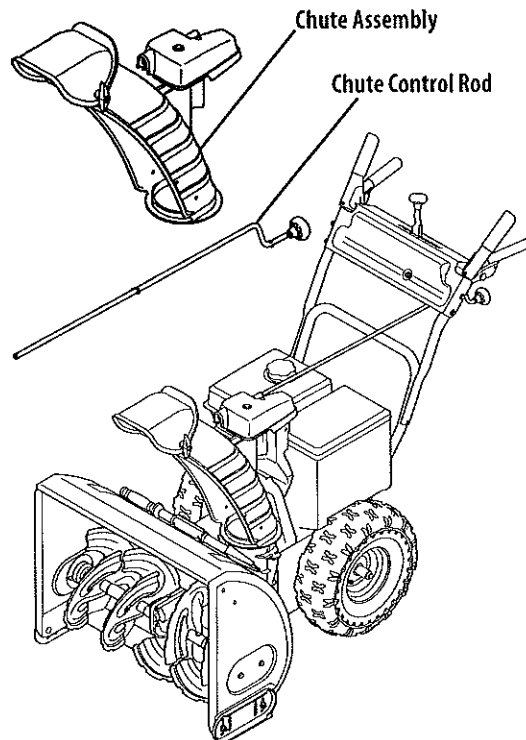

Figure 12

1. Remove wing nut (a) and hex screw (b) from chute control head and clevis pin (c) and cotter pin (d) from chute support bracket. Position chute assembly (forward-facing) over chute base and chute support bracket (Figure 13).

# ASSEMBLY

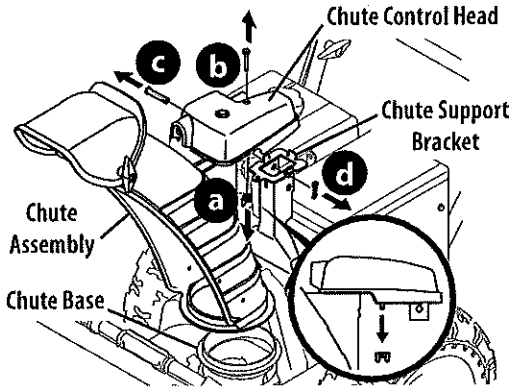

Figure 13

- Secure chute control head to chute support bracket with clevis pin (c) and cotter pin (d) removed in Step 1 (Figure 14).

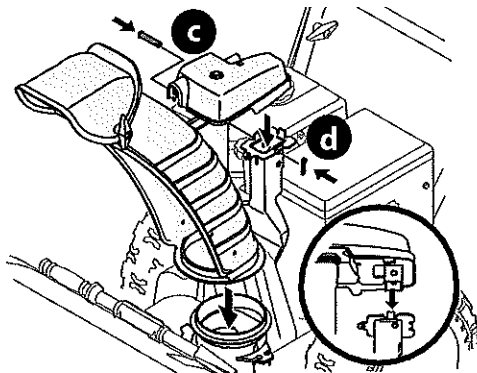

Figure 14

- Finish securing chute control head to chute support bracket with wing nut (a) and hex screw (b) removed in Step 1 (Figure 15).

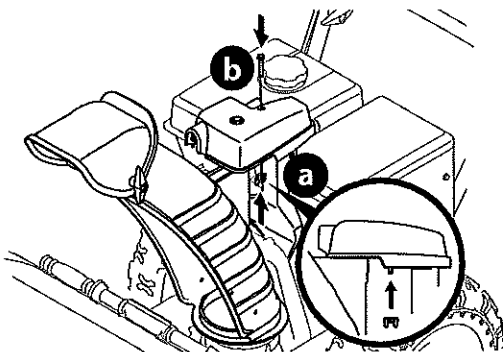

Figure 15

- Insert chute control rod into the support bracket on rear of the dash panel (Figure 16).

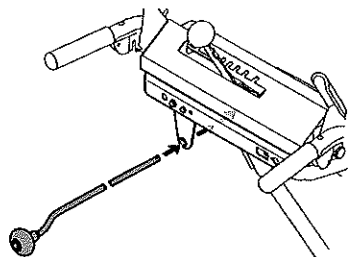

Figure 16

- Remove hairpin clip (a) from rear of chute control head (Figure 17).

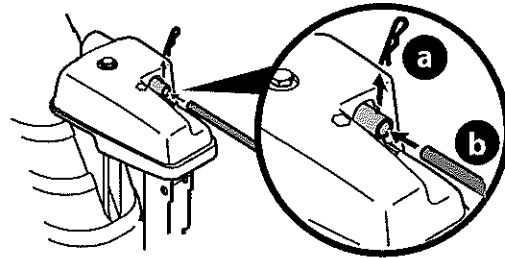

Figure 17

- Insert chute control rod (b) into rear of chute control head (Figure 17) and secure with hairpin clip (a) removed in Step 5.

**STOP**

Continue to Set-Up (page 14).

## Overhead Chute Rotation Control w/ 2-Way Pitch or 4-Way Pitch & Rotation Control

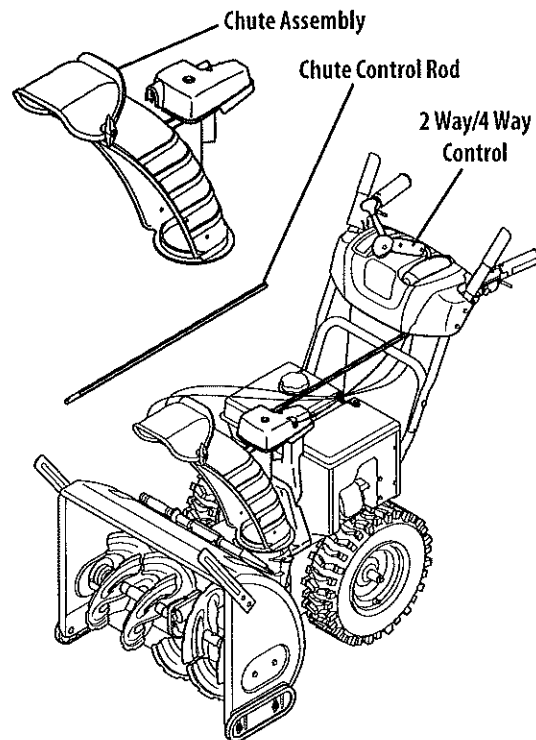

Figure 18

- Remove hairpin clip (a), wing nut (b) and hex screw (c) from chute control head and clevis pin (d) and bow-tie cotter pin (e) from chute support bracket (Figure 19).

# ASSEMBLY

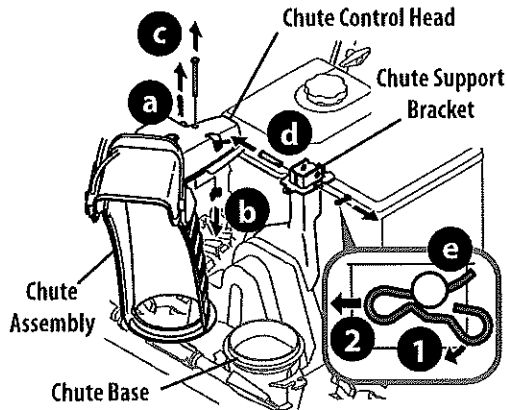

Figure 19

**NOTE:** For smoothest operation, cables should all be to the left of the chute control rod.

2. Insert chute control rod into chute control head. Push rod as far into chute control head as possible, keeping holes in rod pointing upward (Figure 20).

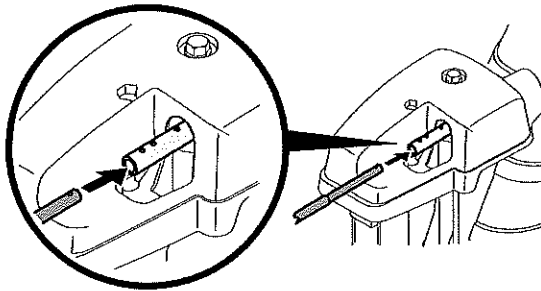

Figure 20

3. Place chute assembly onto chute base and ensure chute control rod is positioned above lower handle. Install hex screw (c) removed in Step 1, but do not secure with wing nut at this time (Figure 21).

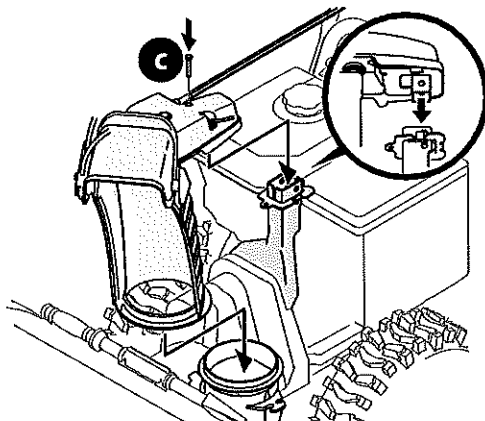

Figure 21

4. Squeeze trigger on 2-way/4-way chute control and rotate chute by hand to face forward. The holes in chute control collar will be facing up (Figure 22).

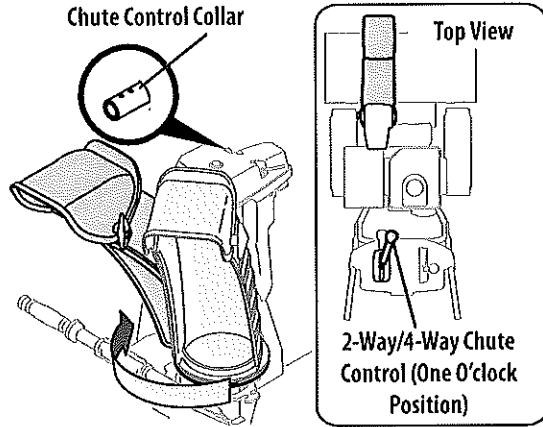

Figure 22

**IMPORTANT:** Chute will not rotate without squeezing trigger on 2-way/4-way chute control.

5. Rotate 2-way/4-way chute control to one o'clock position (Figure 22) so that indicator arrow on pinion gear below control handle faces upward (Figure 23).

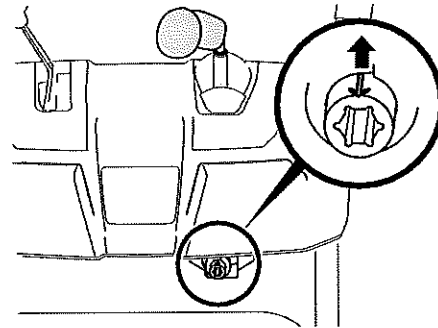

Figure 23

6. Insert chute control rod into pinion gear under handle panel. Make sure to line up hole in rod with arrow on pinion gear (Figure 24).

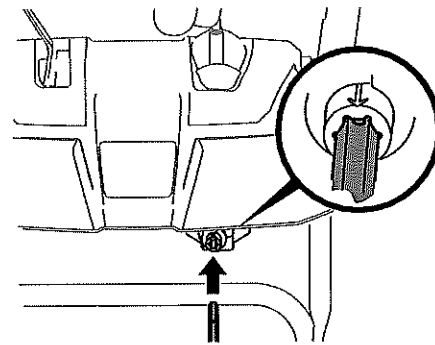

Figure 24

**NOTE:** Chute control rod will fit snug into pinion gear. Support rear of handle panel with one hand while inserting rod with your other hand to ensure rod is inserted **all the way** into pinion gear.

**NOTE:** The hole in the chute control rod is a reference for aligning rod with indicator arrow on pinion gear, and will be visible after rod has been fully inserted.

# ASSEMBLY

- Push chute control rod toward control panel until hole in rod lines up with hole in chute control input collar closest to chute control head and insert hairpin clip (a) removed in Step 1 (Figure 25).

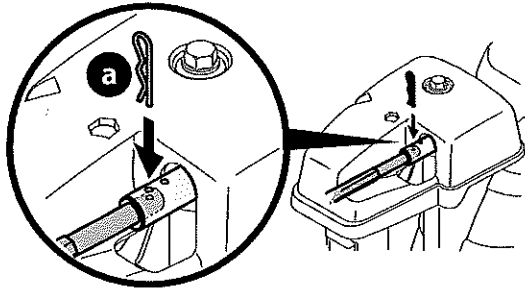

Figure 25

**NOTE:** Second hole is used to achieve further engagement of chute control rod into pinion gear, if required. Refer to Product Care section for Chute Control Rod adjustments.

- Finish securing chute control head to chute support bracket with wing nut (b), clevis pin (d), and bow-tie cotter pin (e) removed in Step 1.

**STOP**

Continue to Set-Up (page 14).

## Overhead Chute Control (Flex Shaft) w/ Steel Chute & 2-Way Pitch Control

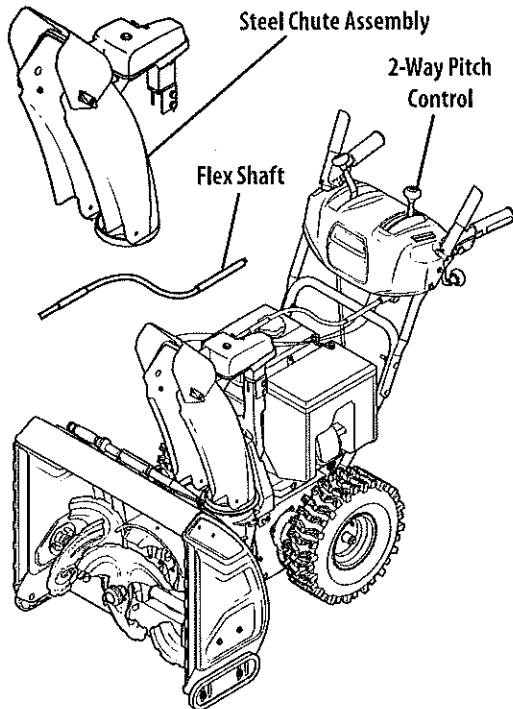

Figure 26

- Remove lock nuts (a) and hex screws (b) from chute support bracket (this will require two wrenches) (Figure 27).

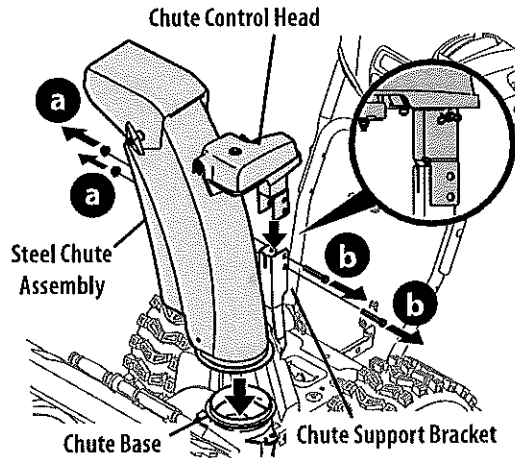

Figure 27

- Place steel chute assembly onto chute base and chute control head onto chute support bracket (Figure 27).
- Secure chute control head to chute support bracket with lock nuts (a) and hex screws (b) removed in Step 1 (Figure 28).

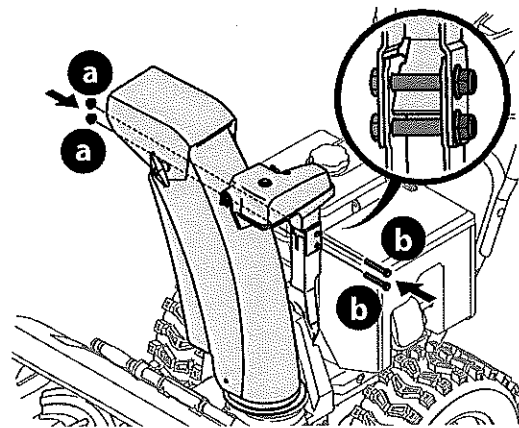

Figure 28

**NOTE:** For smoothest operation, cables should all be to the left of the chute control rod.

- Remove hairpin clip (a) from rear of chute control head (Figure 29).

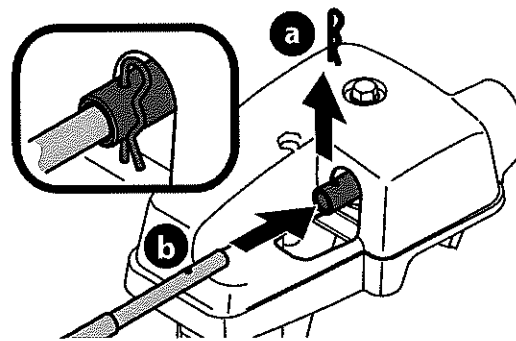

Figure 29

- Insert flex shaft (b) into rear of chute control head and secure with hairpin clip (a) removed in Step 4 (Figure 29).

# ASSEMBLY

6. Perform one of the following to connect the flex shaft to the chute control rod coupling:

- Models with Overhead Rotational - Insert hex end of flex shaft into chute control rod coupling under handle panel (Figure 30).

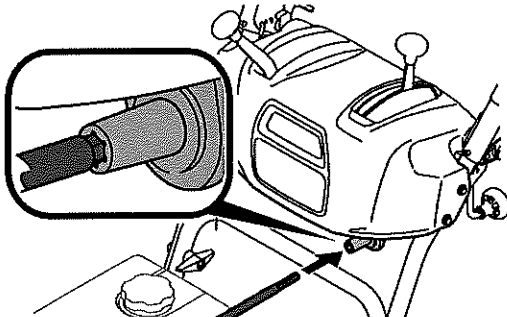

Figure 30

- Models with Electric Chute Control - Insert other end of flex shaft into chute control rod coupling under handle panel. Make sure to line up flat end of rod and flat end of coupler. You may need to rotate rod around until these two surfaces line up (Figure 31 inset).

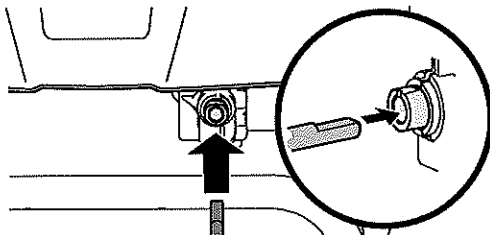

Figure 31

7. Ensure speed selector is in fastest forward speed.
8. Remove cotter pin (a) and washer (b) from ferrule on end of shift rod (Figure 32 inset).

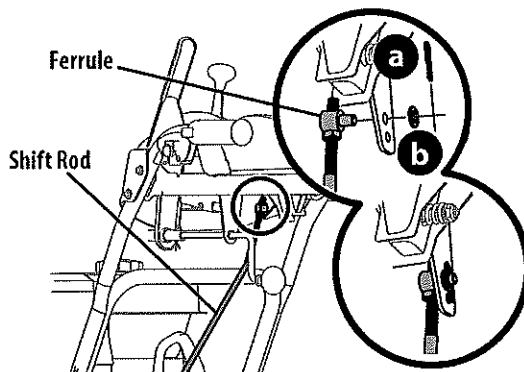

Figure 32

9. Make sure the shift lever on the back of the transmission is rotated downward to the full extent of its rotation see Figure 33, Detail "A" for models without hydro transmission or Detail "B" for models with hydro transmission.

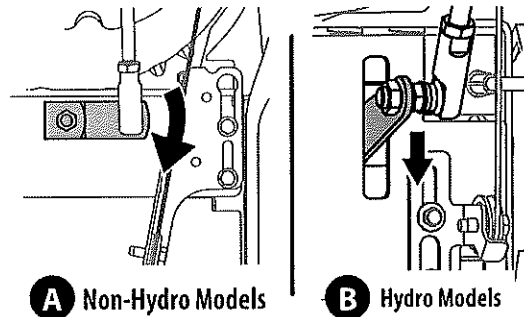

Figure 33

10. Insert ferrule into top hole of shift lever and secure with cotter pin (a) and washer (b) removed in Step 8 (Figure 32). Ferrule may need to be adjusted up or down.

**STOP**

Continue to Set-Up (page 14).

## Overhead Chute Rotation Control w/ 4-Way Electric Pitch & Rotation Control

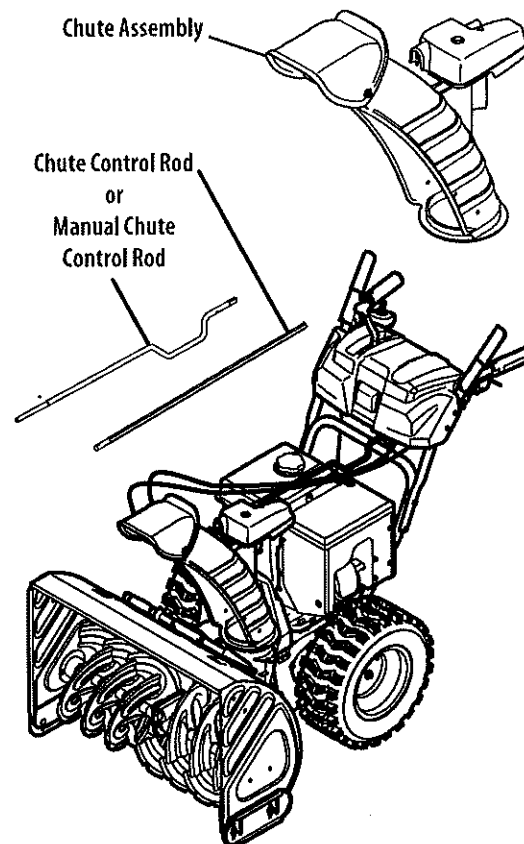

Figure 34

1. Remove cotter pin (a), wing nut (b) and hex screw (c) from chute control head. Remove clevis pin (d) and bow-tie cotter pin (e) from chute support bracket (Figure 35).

# ASSEMBLY

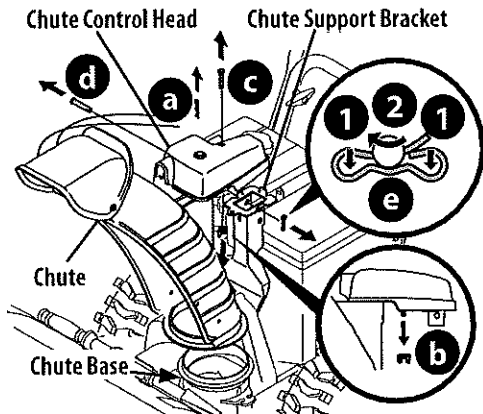

Figure 35

**NOTE:** For smoothest operation, cables should all be to the left of the chute control rod.

2. Insert round end of chute control rod into chute control head. Push rod as far into chute control head as possible, keeping holes in rod pointing upward (Figure 36).

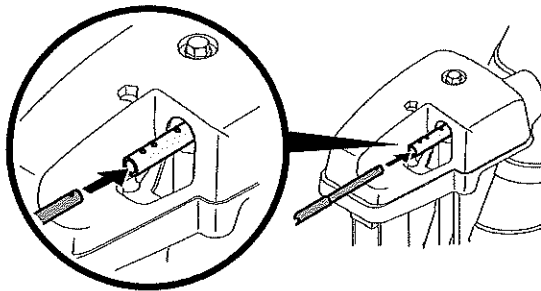

Figure 36

3. Place chute onto chute base and ensure chute control rod is positioned above lower handle. Secure chute control head to chute support bracket with clevis pin (d) and bow-tie cotter pin (e) removed in Step 1 (Figure 37).

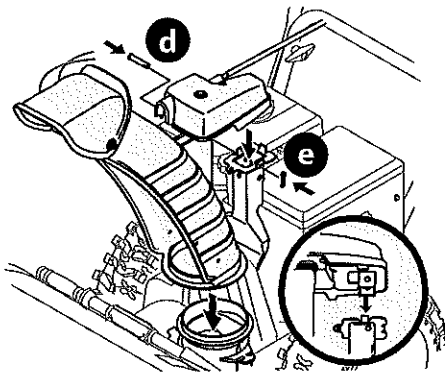

Figure 37

4. Finish securing chute control head by installing hex screw (c) and wing nut (b) removed in Step 1 (Figure 38).

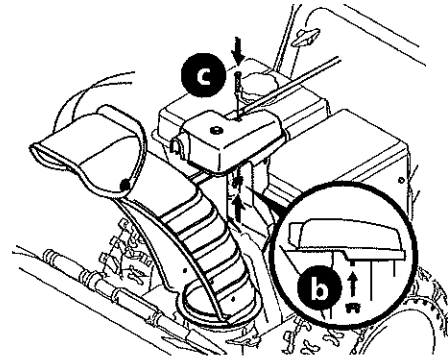

Figure 38

5. Insert other end of chute control rod into coupler below handle panel. Make sure to line up flat end of rod and flat end of coupler. You may need to rotate rod around until these two surfaces line up (Figure 39 inset).

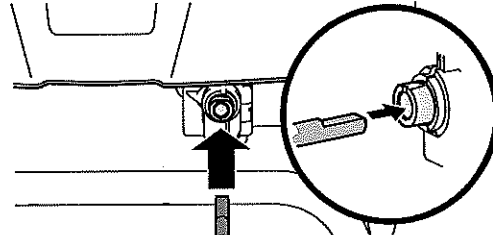

Figure 39

6. Push chute control rod toward the control panel until hole in rod lines up with middle hole in chute control coupler and insert cotter pin (a) removed in Step 1 (Figure 40).

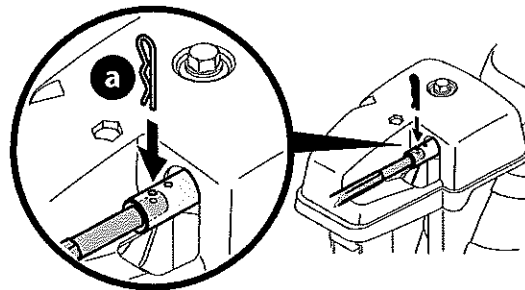

Figure 40

**NOTE:** There is a reference hole provided at rear end of control rod to help know when holes are vertical.

**NOTE:** Hole furthest from chute control head is used to achieve further engagement of chute control rod into coupler, if required. Refer to Adjustments, Overhead Chute Control on page 16.

**NOTE:** For models equipped with manual chute control rods, the hole closest to chute control head is used for manual movement of chute assembly, if required. Refer to Operation, Manual Chute Rotation Control & Electric Chute Control on page 22.

● STOP

Continue to Set-Up (page 14).



# ASSEMBLY

## Set-Up

### CHUTE CONTROL CABLE ROUTING (IF EQUIPPED)

For models equipped with 2-way or 4-way chute controls, electric chute control and/or chute-pitch controls, ensure control cables are routed properly.

Chute control cables are routed through a single wire guide (a) on top of the engine and/or through two wire guides (b) located on the front and left side of the engine (Figure 41).

**NOTE:** On models equipped with a cable tie securing the cables to the rear of the gas tank, pull the cables toward the chute and pull the cable tie snug to secure the cables in place.

**NOTE:** For smoothest operation, cables should all be to the left of the chute control rod (c).

**NOTE:** The number of cables routed through the wire guides will vary depending on model.

1. Locate cable guide(s) and perform the following:
  - Top Mounted Wire Guide (a) - Check that all cables are properly routed through cable guide on top of engine (Figure 41).
  - Front and Side Mounted Wire Guides (b) - Check that all cables are properly routed through the wire guide below the left side of the engine and the wire guide below the chute control head (Figure 41).

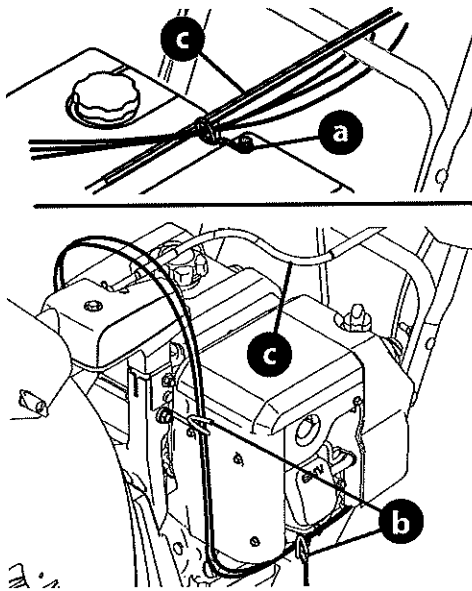

Figure 41

### SHEAR PINS STORAGE (IF EQUIPPED)

On select models, holes are provided in the rear of the handle panel for shear pin (a) and bow-tie cotter pin (b) storage as shown in Figure 42. If not provided, make sure to store them in a safe place until needed.

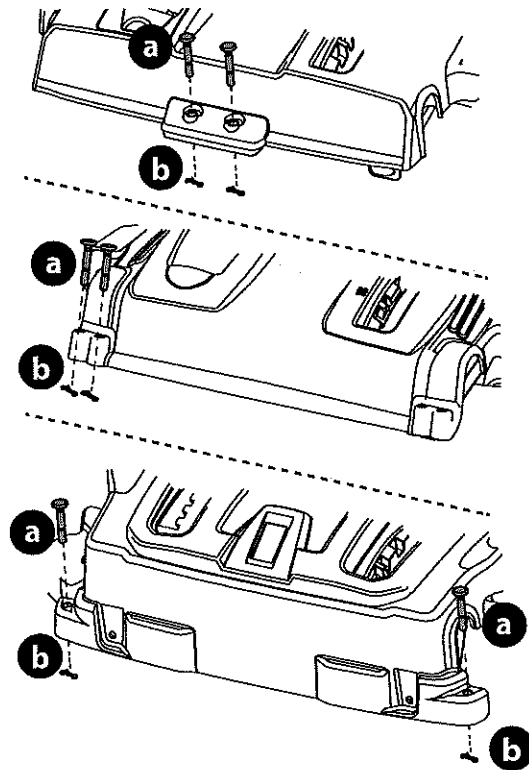

Figure 42

### DRIFT CUTTERS (IF EQUIPPED)

The drift cutters are mounted inverted at the factory for shipping purposes.

#### Non-Adjustable

1. Remove two carriage bolts (a) and lock nuts (b) that secure each drift cutter, and remove them from the sides of auger housing (Figure 43).

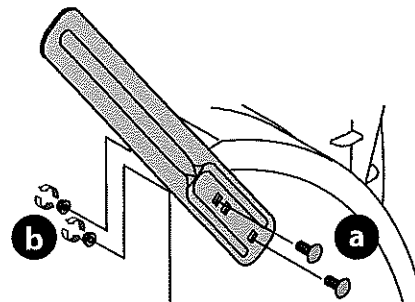

Figure 43

2. Turn the drift cutters around and position them as shown in Figure 43 to the outside of the auger housing.
3. Attach drift cutters with carriage bolts (a) and lock nuts (b) removed in Step 1.

#### Tool-less

1. Remove two carriage bolts (a) and wing nuts (b) that secure each drift cutter, and remove them from the sides of auger housing (Figure 44).

## ASSEMBLY

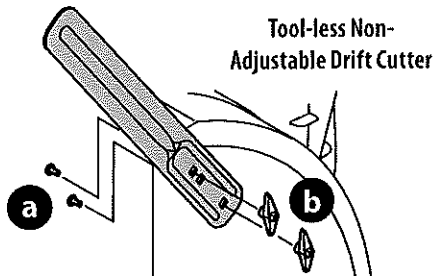
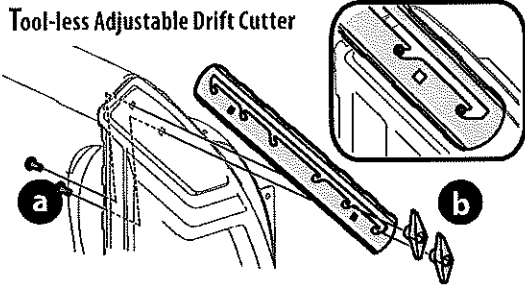

Figure 44

2. Turn the drift cutters around and position them as shown in Figure 44 to the outside of the auger housing.
3. Attach drift cutters with carriage bolts (a) and wing nuts (b) removed in Step 1.

### SKID SHOES (IF APPLICABLE)

Select models require the installation to the provided skid shoes.

1. Using the two carriage bolts (a) and hex flange nuts (b) and flat washers (if equipped) (c), secure the skid shoes to the auger housing (d). Hand tighten hex flange nuts (Figure 45).
2. Adjust the skid shoes to provide a minimum of 1/8th inch clearance between the shave plate (e) and the ground. Securely tighten hex flange nuts.
3. If necessary refer to Skid Shoes in the Adjustments section on page 15.

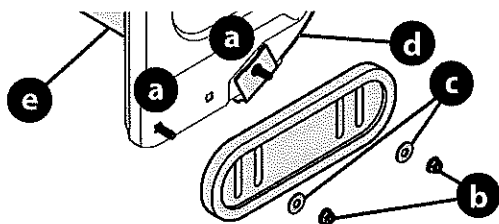

Figure 45

### CHUTE CLEAN-OUT TOOL

The chute clean-out tool is fastened to the top of the auger housing with a mounting clip (Figure 46).

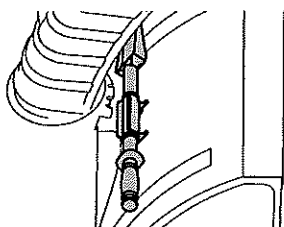

Figure 46

### TIRE PRESSURE (IF APPLICABLE)

**NOTE:** Not applicable to models equipped with airless tires.

### ⚠ WARNING

Under any circumstance do not exceed manufacturer's recommended psi. Equal tire pressure should be maintained at all times. Excessive pressure when seating beads may cause tire/rim assembly to burst with force sufficient to cause serious injury. Refer to sidewall of tire for recommended pressure.

The tires are over-inflated for shipping purposes. Check tire pressure before operating. Refer to tire side wall for tire manufacturer's recommended psi and adjust pressure, if necessary.

**NOTE:** Equal tire pressure is to be maintained at all times for performance purposes.

### Adjustments

#### SKID SHOES

Snow blower skid shoes are adjusted at a factory setting roughly 1/8" below the shave plate. Adjust them upward or downward, if desired, prior to operating.

### ⚠ WARNING

Use extreme caution when operating on or near gravel and adjust skid shoes to clear gravel or crushed rock surfaces to avoid picking up and throwing objects which could cause serious injury or property damage.

- For close snow removal on a smooth surface, raise skid shoes higher on auger housing.
- Use a lower position when area to be cleared is uneven, such as a gravel driveway.

**IMPORTANT:** If you choose to operate on a gravel surface, keep skid shoes in position for maximum clearance between ground and shave plate.

1. Loosen four hex nuts (a) (two on each side) and carriage bolts (b). Move skid shoes to desired position (Figure 47).

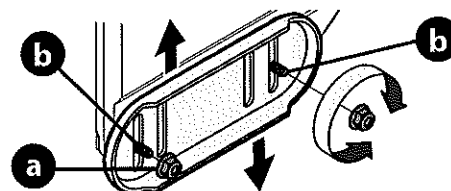

Figure 47

**NOTE:** The skid shoes on your snow blower may look slightly different (and have different hardware) than ones shown in Figure 47.

2. Make certain entire bottom surface of skid shoe is against ground to avoid uneven wear on skid shoes.
3. Securely tighten hex nuts (a) to carriage bolts (b).