



富基电子（深圳）有限公司

FUJI ELECTRONICS (SHENZHEN) CO., LTD.

Rechargeable Li-Ion Battery

Technical Data Sheet

产品型号 Product Model:	18650(11NR19/66-4)
产品代码 Product Code	539043S
容量 Capacity.:	13000mAh
客户代码 Customer Code:	539
规格书编号 Specification No.:	
文件版本 REV:	A2

 FUJI ELECTRONICS (SHENZHEN) CO.,LTD.		
拟制 Prepared	品质检验 Quality Checkout	核准 Approved
陈晓东	王虎	梁荣钦
2021-05-12	2021-05-12	2021-05-12

Customer Approval 客户承认	Company Name: 公司名称:	
	Customer Model : 客 户 型 号 :	
	Part No.: 部 件 编 号:	
	Signature 签 名	Date 日 期

厂址：深圳市宝安区松岗街道塘下涌第二工业区第十栋

Address: Bld.10, 2rd Industrial Park TangXiaYong, SongGang, BaoAn, ShenZhen, China

电话 (TEL): +86-755-33893788 传真 (FAX): +86-755-33895166



文件名称 File Name	电池规格书 Battery Spec.	产品型号 Product model	18650(1INR19/66-4)
文件编号 Document No.		文件版本 Version	A2
日期 Date	2021-05-12	页码 Page	1/ 18

修订履历表

History of Change

序号 No.	版本 Rev.	修订内容 Content of Change	修订者 Prepared	日期 Date
1	A1	Only for reference	HP_Liu	2020-12-29
2	A2	按客户要求要求在条码出增加自动化生产“D”标识	陈晓东	2021-05-12



文件名称 File Name	电池规格书 Battery Spec.	产品型号 Product model	18650(1INR19/66-4)
文件编号 Document No.		文件版本 Version	A2
日期 Date	2021-05-12	页码 Page	2/ 18

目录

Table of Content

1、目的 Scope.....	3
2、依据标准 Test reference standard.....	3
3、基本参数 Key parameters.....	3
4、测试方法和定义 Test methods and definitions.....	4
5、技术指标 Technical indicators.....	5
6、保护板规格与特性 PCM Spec. and characteristic.....	10
7、装配结构 Assembly configuration.....	13
9、环保要求 Environmental requirements.....	15
10、外观 Cosmetic requirements.....	15
11、运输、贮存 Transportation and storage.....	15
12、安全规程和使用说明 Safeguard and instruction.....	16
13、质量评定程序 Quality Assessment Procedures.....	18
14、保质期限 Guaranteed Deadline.....	18
15、其他事项 Miscellaneous.....	18

	文件名称 File Name	电池规格书 Battery Spec.	产品型号 Product model	18650(11NR19/66-4)
	文件编号 Document No.		文件版本 Version	A2
	日期 Date	2021-05-12	页码 Page	3/ 18

1、目的 Scope

本规格书适用于富基电子（深圳）有限公司生产的锂离子电池，它是产品设计、生产和检验的依据,其作用是让顾客了解产品的质量及正确使用方法.

This specification shall be applied to Li-ion battery manufactured by FUJI ELECTRONICS (SHENZHEN) Co., LTD. It is the basis of the product design, production and testing; The purpose is to let customers understand the quality and proper use of the product;

2、依据标准 Test reference standard

本产品依据标准：GB31241-2014《便携式电子产品用锂离子电池和电池组安全要求》。

The battery is tested in reference to the standard of GB 31241-2014 *Safety Requirements for Lithium Ion Batteries and Batteries used in Portable Electronic Devices.*

3、基本参数 Key parameters

序号 No.	项目 Items	规格 Specifications	备注 Conditions
1	型号 Model No.	18650(11NR19/66-4)	
2	电池类型 Battery Type	Rechargeable Li-ion Battery	
3	电池结构 Battery Configuration	1S4P	
4	标称容量 Rated Capacity	13000mAh	以 0.2C 电流从 4.2V 放电至 2.8V; Discharge from 4.2V/0.2C to 2.8V
5	最小容量 Minimum Capacity	12300mAh(TBD)	
6	标称电压 Rated Voltage	3.6V	
7	内阻 Internal Resistance	≤90mΩ	(AC impedance@1kHz,50%SOC,23±2℃)
8	电池重量 Battery Weight	Approx:200g	
9	出货状态电压 As of shipment Voltage	3.52 ~3.75V	
10	充电截止电压 Charge cut-off voltage	4.2V	
11	通讯方式 Communication methods	I2C	SCL SDA
12	充电电流 Charge Current	0.2C	标准充电电流 Standard charge current
		0℃~10℃: 0.2C 10℃~45℃: 3.0A	最大充电电流 Max charge current
13	放电电流 Discharge current	0.2C	标准放电电流 Standard discharge current
		3.0A	最大持续放电电流 Maximum continuous discharge current

	文件名称 File Name	电池规格书 Battery Spec.	产品型号 Product model	18650(1INR19/66-4)
	文件编号 Document No.		文件版本 Version	A2
	日期 Date	2021-05-12	页码 Page	4/ 18
14	工作温度 Operating Temperature(°C)	Charging:0°C~45°C 充电: 0°C~45°C	0°C~10°C: Charge current Max0.2C; Charge voltage 4.2V. 0°C~10°C: 最大充电电流 0.2C, 充电电压 4.2V. 10°C~45°C: Charge current Max3A; Charge voltage 4.2V. 10°C~45°C: 最大充电电流 3A, 充电电压 4.2V.	
		Discharging: -20°C~60°C 放电: -20°C~60°C		
15	存储温度 Storage Temperature(°C)	(50±10)% SOC		
		-5~45°C	≤1months	
		-5~45°C	≤3months	
		-5~30°C	≤12months	
16	Guaranteed Deadline 保质期期限	Guaranteed Deadline of this product is 12 months from manufacture code 保质期期限从出厂日期开始算 12 个月		

4、测试方法和定义 Test methods and definitions

4.1 测试条件 Test conditions

除非另有规定，本规格书中各项试验应在以下大气条件下进行：

Unless otherwise specified, tests in this specification should be conducted at the following atmospheric conditions:

温度：25°C±2°C；

Temperature: 25°C±2°C；

相对湿度：45~75%RH；

Relative humidity: 45~75%RH；

大气压力：86 KPa~106 KPa

Atmospheric pressure: 86 KPa-106 KPa

4.2 测量仪表与设备要求 Test instruments requirements

测量电压的仪表准确度应不低于±0.5%。

The precision of voltage measuring instrument should not be lower than ±0.5%.

测量电流的仪表准确度应不低于±0.5%。

The precision of current measuring instrument should not be lower than±0.5%

测量时间用的仪表准确度应不低于±0.1%。

The precision of time measuring instrument should not be lower than ±0.1%

测量温度的仪表准确度应不低于±0.5°C。

The precision of temperature measuring instrument should not be lower than ±0.5°C

恒流源的电流可调，在恒流充电或放电过程中，其电流的相对变化应在±1% 范围内。

The current of the constant current power supply can be adjusted; the relative variation of its current should be in the range of ±1% at constant charge or discharge

恒压源的电压可调，在恒压充电过程中，其电压变化应在±1%范围内。

The voltage of the constant current power supply can be adjusted; the relative variation of its voltage should be in the range of ±1% at constant charge

测量重量用的仪器准确度应不低于 1%。

The precision of weight measuring instrument should not be lower than 1%



文件名称 File Name	电池规格书 Battery Spec.	产品型号 Product model	18650(1INR19/66-4)
文件编号 Document No.		文件版本 Version	A2
日期 Date	2021-05-12	页码 Page	5/ 18

4.3 标准充电 Standard charge

在环境温度为 $25^{\circ}\text{C}\pm 2^{\circ}\text{C}$ 条件下，用 0.2C 电流对电池充电，当电压到 4.2V 时，改为 4.2V 恒压充电，直到电流小于或等于 0.02C，停止充电，充电时间不大于 8h。

Charge the battery at 0.2C to 4.2V at ambient temperature of $25^{\circ}\text{C}\pm 2^{\circ}\text{C}$, and then charge at constant voltage of 4.2V to current less than or equal to 0.02C. Stop the charging. The charging time is not more than 8 hours.

4.4 标准放电 Standard discharge

在环境温度为 $25\pm 2^{\circ}\text{C}$ 条件下，用 0.2C 放电到 2.8V。

Discharge the battery at 0.2C to 2.8V at ambient temperature of $25^{\circ}\text{C}\pm 2^{\circ}\text{C}$.

5、技术指标 Technical indicators

5.1、常规电性能 Conventional electrical properties

序号 No.	检验项目 Test item	检验方法 Test method	判定标准 Criteria
5.1.1	荷电保持能力及恢复容量 Capacity retention and recovered capacity	电池按 4.3 规定充电结束后，在环境温度为 $25^{\circ}\text{C}\pm 2^{\circ}\text{C}$ 条件下，将电池开路搁置 28d，再以 0.2C 电流恒流放电至 2.8V。 Charge the battery per section 4.3 and store the battery for 28 days at ambient temperature of $25^{\circ}\text{C}\pm 2^{\circ}\text{C}$. Discharge the battery at constant current of 0.2 C to 2.8V.	容量 $\geq 85\%$ \times 最小容量 Capacity $\geq 85\% \times$ Minimum Capacity.
5.1.2	存储性能 Storage performance	电池储存前按 4.3 规定的方法给电池充入 40%~45% 的容量，然后在环境温度 $25^{\circ}\text{C}\pm 2^{\circ}\text{C}$ ，相对湿度 45%~75% 的环境中储存 12 个月。然后再按 4.3 规定充电后，在 $25^{\circ}\text{C}\pm 2^{\circ}\text{C}$ 的温度环境下以 0.2C 放电至终止电压。充放电试验可以循环 5 次。 Before storage, charge the battery to 40% to 50% capacity per section 4.3, After that, store the batteries at the ambient temperature of $25^{\circ}\text{C}\pm 2^{\circ}\text{C}$ and relative humidity of 45% to 75% for 12 months and charge as per section 4.3, and discharge at 0.2 C to the cut-off voltage. The charge and discharge test may be cycled for 5 times.	容量 $\geq 75\%$ \times 最小容量 Capacity $\geq 75\% \times$ Minimum Capacity.
5.1.3	循环寿命 Cycle life	在环境温度为 $25^{\circ}\text{C}\pm 2^{\circ}\text{C}$ 条件下，以 3A 充电，当电池端电压达到 4.2V 时，改为恒压充电，截止电流为 0.05C，总时间不大于 8h，搁置 0.5h，然后以 3A 电流放电到终止电压，放电结束后，搁置 15min，再进行下一个充放电循环。 Charge the battery at 3A at ambient temperature of $25^{\circ}\text{C}\pm 2^{\circ}\text{C}$ until voltage reaches 4.2V, and then charge at constant current to current less than or equal to 0.05C. Total charging time should not be more than 8 hours. After that, store the battery for 0.5 hour and discharge at 0.5C to the cut-off voltage. When the discharge is finished, store the battery for 15 minutes before proceeding to the next charge and discharge cycle.	500 个循环后容量保持率在 80% 以上。 Capacity retention rate after 500 cycles should be more than 80%

	文件名称 File Name	电池规格书 Battery Spec.	产品型号 Product model	18650(11NR19/66-4)
	文件编号 Document No.		文件版本 Version	A2
	日期 Date	2021-05-12	页码 Page	6/ 18

5.1.4	高温性能 High temperature performance	<p>电池按 4.3 规定充电结束后,放入 55℃±2℃的高温箱中恒温 2h, 然后以 0.2C₅A 电流放电至 2.8V, 放电时间应符合判定标准。</p> <p>该试验结束后,将电池取出在环境温度 25℃±2℃的条件下搁置 2h, 然后目测电池外观, 应符合判定标准。</p> <p>Charge the battery per section 4.3, then place at 55℃±2℃ high temperature chamber and keep at that temperature for 2 hours and discharge at 0.2C₅A to 2.8V. The discharging time should meet the criteria.</p> <p>After the test, take out the battery and place at ambient temperature of 25℃±2℃ for 2 hours. Visually inspect the battery and the battery should meet the criteria.</p>	<p>容量 ≥ 100% × 最小容量</p> <p>电池外观应无变形、无爆裂。</p> <p>Capacity ≥ 100% × Minimum Capacity.</p> <p>No cosmetic deformation, no rupture</p>
5.1.5	低温性能 Low temperature performance	<p>电池按 4.3 规定充电结束后,放入 -10℃±2℃的低温箱中恒温 4h, 然后以 0.2C₅A 电流放电至 2.8V, 放电时间应符合判定标准。</p> <p>该试验结束后,将电池取出在环境温度 25℃±2℃的条件下搁置 2h, 然后目测电池外观, 应符合判定标准。</p> <p>Charge the battery per section 4.3, then place at -10℃±2℃ low temperature chamber and keep at that temperature for 4 hours and discharge at 0.2 C₅A to 2.8V. The discharging time should meet the criteria.</p> <p>After the test, take out the battery and place at ambient temperature of 25℃±2℃ for 2 hours. Visually inspect the battery and the battery should meet the criteria</p>	<p>容量 ≥ 75% × 最小容量</p> <p>电池外观应无变形、无爆裂。</p> <p>Capacity ≥ 75% × Minimum Capacity.</p> <p>No cosmetic deformation, no rupture</p>

5.2 环境适应性 Environmental adaptability

序号 No.	检验项目 Test item	检验方法 Test method	判定标准 Criteria
5.2.1	恒定湿热性能 Constant temperature and humidity performance	<p>电池按 4.3 规定充电结束后, 将电池放入 (40±2)℃, 相对湿度为 90%-95%的恒温恒湿箱中搁置 48h 后, 将电池取出在环境温度为 25℃±2℃条件下搁置 2h, 目测电池外观, 再以 0.2C₅A 电流恒流放电至终止电压。</p> <p>Charge the battery per section 4.3, and then put the battery into a chamber with constant temperature of 40℃±2℃ and constant humidity of 90% to 95% for 48 hours. After that, take out the battery and put it at ambient temperature of 25℃±2℃ for 2 hours. Visually check the appearance of the battery and discharge at constant current of 0.2C₅A to the cut-off voltage.</p>	<p>容量 ≥ 80% × 最小容量</p> <p>无变形、无锈蚀、不泄漏、不泄气、不破裂、不起火和不爆炸,</p> <p>Capacity ≥ 80% × Minimum Capacity</p> <p>No cosmetic deformation, no rusting, no leak, no venting, no rupture, no fire and no explosion.</p>



	文件名称 File Name	电池规格书 Battery Spec.	产品型号 Product model	18650(11NR19/66-4)
	文件编号 Document No.		文件版本 Version	A2
	日期 Date	2021-05-12	页码 Page	8/ 18



图 1 温度循环流程示意图

Charge the battery per section 4.4 and place the battery at $25^{\circ}\text{C} \pm 2^{\circ}\text{C}$ temperature control chamber and go through the following steps (see figure 1) :

- Place the battery at $75^{\circ}\text{C} \pm 2^{\circ}\text{C}$ test chamber and maintain for 6 hours.
- Decrease the test chamber temperature to $-40^{\circ}\text{C} \pm 2^{\circ}\text{C}$ and maintain for 6 hours.
- The temperature transition time is no greater than 30 minutes.
- Repeat step a to step b, cycle 10 times in total.

5.3 安全保护性能

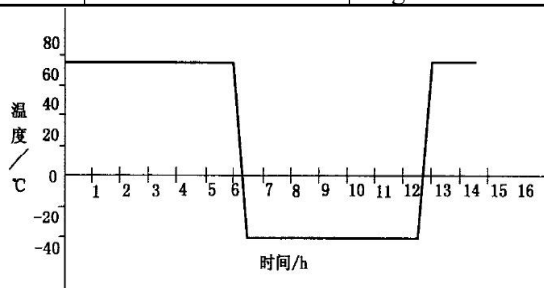
(注：以下安全性能试验应在有保护措施的条件下进行。)

Safety and Protection Performance Note: Adequate safeguard should be employed in conducting the following tests.

序号 No.	检验项目 Test item	检验方法 Test method	判定标准 Criteria
5.3.1	过充电保护 Over charge protection	电池按 4.4 规定充电结束后,将电池以 2 倍标称电压、 $2C_5A$ 电流恒流恒压充电 7h, 电池应符合判定标准。 Charge the battery per section 4.4, and then charge the battery at constant voltage of 2 times of the nominal voltage and at constant current of $2 C_5A$ for 7 hours. After the test. The battery should meet the criteria.	电池应不泄漏、不泄气、不破裂、不起火和不爆炸。 No leak, no venting, no rupture, no fire and no explosion.
5.3.2	过放电保护 Over discharge protection	电池在环境温度为 $23^{\circ}\text{C} \pm 2^{\circ}\text{C}$ 条件下,以 $0.2C_5A$ 放电至终止电压后,外接 30Ω 负载放电 7h, 电池应符合判定标准。 Discharge the battery at $0.2 C_5A$ to the cut-off voltage at ambient temperature of $23^{\circ}\text{C} \pm 2^{\circ}\text{C}$. And then discharge the battery by connecting the battery to a load of 30Ω for 7 hours. After the test, the battery should meet the criteria.	电池应不泄漏、不泄气、不破裂、不起火和不爆炸。 No leak, no venting, no rupture, no fire and no explosion.
5.3.3	短路保护 Short-circuit protection	电池按 4.4 规定充电结束后,将正负极用 $80\text{m}\Omega \pm 20\text{m}\Omega$ 电阻器短路 1h 后,电池应符合判定标准;将正负极断开,电池以 $1C_5A$ 电流瞬时充电 5s 后用电压表测量电池电压,应符合判定标准。 Charge the battery per section 4.4, and then short-circuit the battery for 1 hour by connecting the positive and	电池应不泄漏、不泄气、不破裂、不起火和不爆炸。瞬时充电后,电池电压应不小于 3.6V。 No leak, no venting, no rupture, no fire and no

	文件名称 File Name	电池规格书 Battery Spec.	产品型号 Product model	18650(1INR19/66-4)
	文件编号 Document No.		文件版本 Version	A2
	日期 Date	2021-05-12	页码 Page	9/ 18
		negative terminals with a resistor of 80±20mΩ. After the test, the battery should meet the criteria. Disconnect the positive and negative terminals, and charge the battery with instantaneous input current of 1 C ₅ A for 5 seconds. The result should meet the criteria	explosion. The battery voltage should not be less than 3.6V after charging with instantaneous input current.	
5.3.4	热滥用 Thermal abuse	将电池放置于热箱中，温度以（5℃±2℃）/min 的速率升温至 130℃±2℃，并保温 30min 然后取出。 Place the battery in an oven, ramp the temperature at（5℃±1℃）/min to 130℃±2℃, maintain the temperature for 30 minutes and take out the battery.	电池应不起火和不爆炸。 No fire and no explosion	
5.3.5	过充电 Over charge	电芯按标准充电模式充电后，接有热电偶的电芯置于通风橱中，连接正负极于一恒流恒压电源，调节电流至 3C ₅ A 电流，电压为 n×4.6V，然后对电芯以 3 C ₅ A 电流充电，直到电芯电压为 n×4.6V，电流将到接近 0A。试验过程中监视电芯温度变化，当电池持续充电时间达到 7h 或电芯温度下降到比峰值低约 20%，结束试验。 本实验是在无电芯外保护线路的情况下进行的。 After standard charging, put the battery in fume hood. Add constant voltage & current n×4.6V 3C to the battery. Charging it until the battery reaches n×4.6V, charging current decreases to almost 0A. Record the temperature curve of the battery. When the battery temperature decreases to about 10℃ lower after reaching the peak temperature. End the test. This test is performed without PCM	不起火、不爆炸 No fire No explosion	
5.3.6	短路测试 Short circuiting test	标准充电后，将接有热电偶的电芯置于通风橱中，短路其正负极(线路总电阻 80 mΩ±20mΩ)。试验过程中监视电芯温度变化，当短路时间达到 24h 或电芯温度下降到比峰值低 20%时，结束试验。 本实验是在无电芯外保护线路的情况下进行的。 After standard charging, put the battery in fume hood. Connect the Negative Pole and Positive pole directly. (the wire's resistance should 80 mΩ±20mΩ. Record the battery's temperature curve during the test. When short time reached 24 hours or the battery temperature decreases about 20% lower after reaching the peak temperature. End the test. This test is performed without PCM	不起火、不爆炸， No fire 、 No explosion	
5.3.7	强制放电 Forced discharge	将电芯以标准放电方式放电至终止电压，然后以 1.0C 的电流对电芯反向充电 The standard batteries discharge mode discharge to the termination voltage, then a current of 1.0C reverse charge batteries	电芯不起火、不爆炸 No fire, No explosion	



文件名称 File Name	电池规格书 Battery Spec.	产品型号 Product model	18650(11NR19/66-4)
文件编号 Document No.		文件版本 Version	A2
日期 Date	2021-05-12	页码 Page	10/ 18

6、保护板规格与特性 PCM Spec. and characteristic

6.1 PCM 规格 (at 25°C) PCM specification (at 25°C)

序号 No.	项目 Item	最小值 Min.	典型值 Typ.	最大值 Max.	备注 Note
1	过充保护电压(V) Overcharge protection voltage (V)	4.225	4.25	4.275	
2	过充保护延迟时间(ms) Overcharge protection delay time(ms)	700	1000	1300	
3	过充恢复电压(V) Overcharge recovery voltage (V)	4.00	4.05	4.10	
4	过放保护电压(V) Over discharge protection voltage(V)	2.73	2.8	2.87	
5	过放保护延迟时间(ms) Over discharge protection delay time(ms)	11	16	21	
6	过放恢复电压(V) Over discharge recovery voltage (V)	2.925	3.0	3.075	
7	放电过流检测电压(V) Over Discharge-current detection voltage (V)	0.135	0.15	0.165	
8	放电过流保护(A) Over Discharge-current protection(A)	3.6	6	10.3	
9	过流保护延迟时间(ms) Over Discharge-current protection delay time (ms)	8	12	16	
10	短路检测电压 (V)	0.5	0.75	0.95	
11	短路保护时间(μs) Short-circuit protection time(μs)	230	300	500	
12	保护板消耗电流(μA) PCM current consumption (μA) 工作模式 Operating mode		15	30	
	休眠模式 Sleep Mode VCC<2.0V		0.5	5	
13	Interior Resistance 内阻 (mΩ)	≤50mΩ			
14	通讯端口 Communication port	I2C			



文件名称 File Name	电池规格书 Battery Spec.	产品型号 Product model	18650(1INR19/66-4)
文件编号 Document No.		文件版本 Version	A2
日期 Date	2021-05-12	页码 Page	11/ 18

6.2 电路原理图 Circuit Diagram

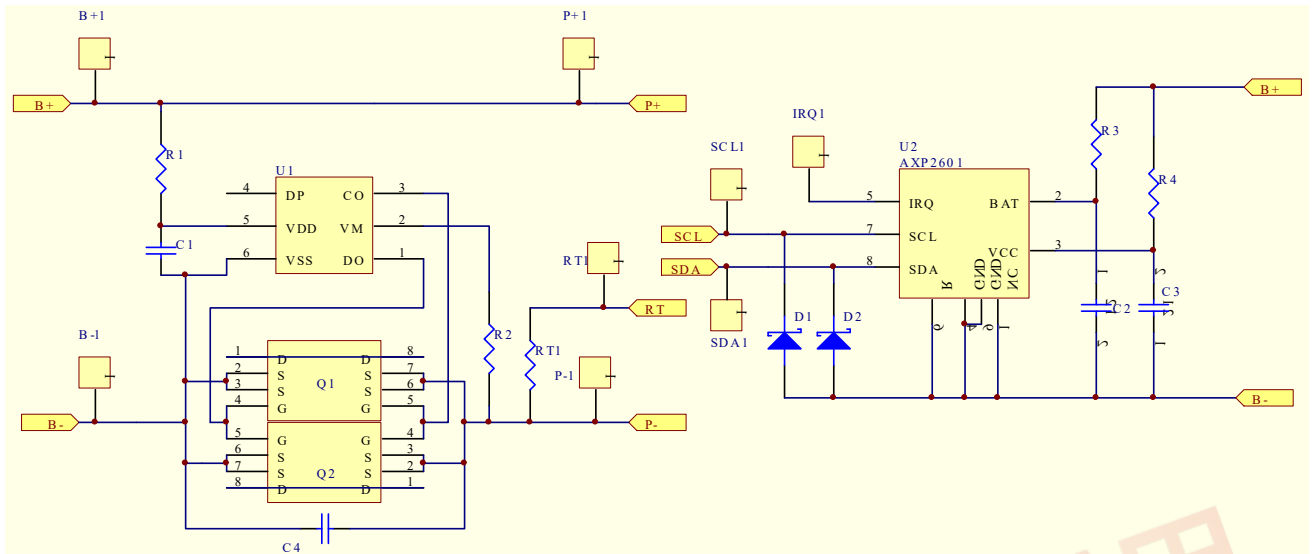

6.3 布线图 Layout drawing

PCB 顶层 TOP Layer

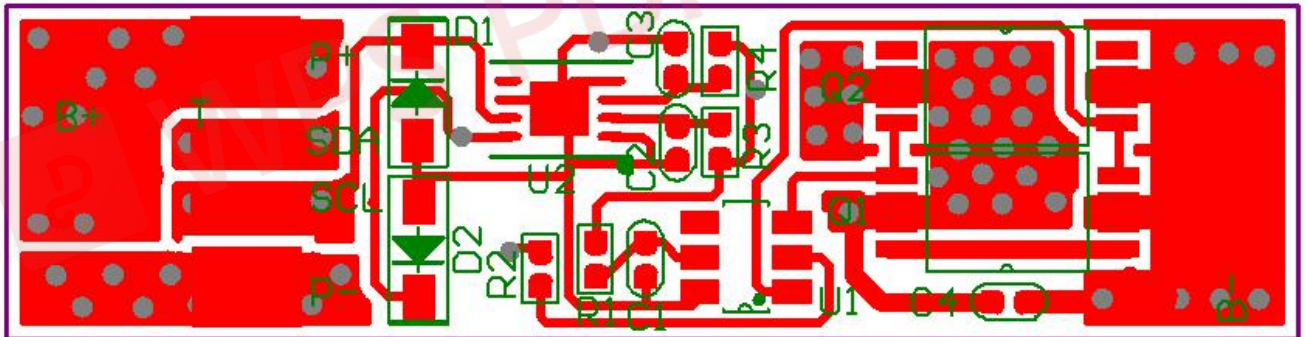

PCB 底层 Bottom Layer

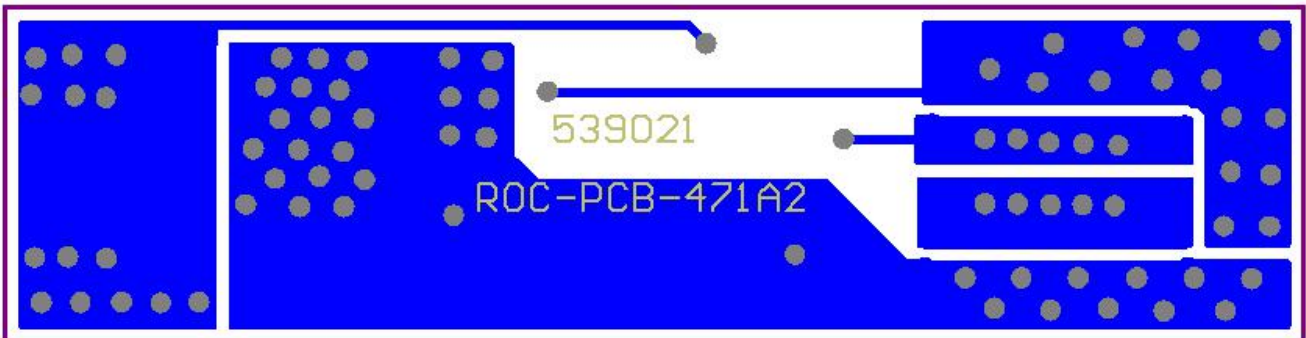



文件名称 File Name	电池规格书 Battery Spec.	产品型号 Product model	18650(11NR19/66-4)
文件编号 Document No.		文件版本 Version	A2
日期 Date	2021-05-12	页码 Page	12/ 18

6.4 保护板主要零件清单 PCM key component list

NO	元件编号	元件名称	元件规格	封装式	数量
1	U1	IC	R5478N218CD 理光 ROHS 编带	SOT-23-6	1
2	Q1 Q2	MOS	8205A ROHS 编带	TSSOP-8	2
3	R1	Resistor	330Ω ±5% 1/16W 国巨 ROHS 编带	0402	1
4	R2	Resistor	1KΩ ±5% 1/16W 国巨 ROHS 编带	0402	1
5	C1	Capacitor	0.01 μF 16V 20%~80% X5R 国巨	0402	1
6	B+	镍片	5*3*0.3mm		1
7	U2	IC	AXP2601 全志 ROHS 编带	DFN8	1
8	R3	Resistor	470Ω ±5% 1/16W 国巨 ROHS 编带	0402	1
9	R4	Resistor	100Ω ±5% 1/16W 国巨 ROHS 编带	0402	1
10	C2 C3	Capacitor	1 μF 16V 20%~80% X5R 国巨	0402	2
11	C4	Capacitor	0.1 μF 16V 20%~80% X5R 国巨	0402	1
12	PCB	/	ROC-PCB-471A2 539021 2层 喷锡 绿油白字 ROHS 尺寸: 35*9*0.8mm FR-4 铜厚 1盎司 公差: 长±0.15mm 宽/厚±0.1mm		1

Note: 标有“*”的物料为替代料。

Note: The material marked with an asterisk (*) is alternative material.



文件名称 File Name	电池规格书 Battery Spec.	产品型号 Product model	18650(11NR19/66-4)
文件编号 Document No.		文件版本 Version	A2
日期 Date	2021-05-12	页码 Page	13/ 18

7、装配结构 Assembly configuration

7.1 电池尺寸结构 (单位 mm) Dimension (Unit :mm)

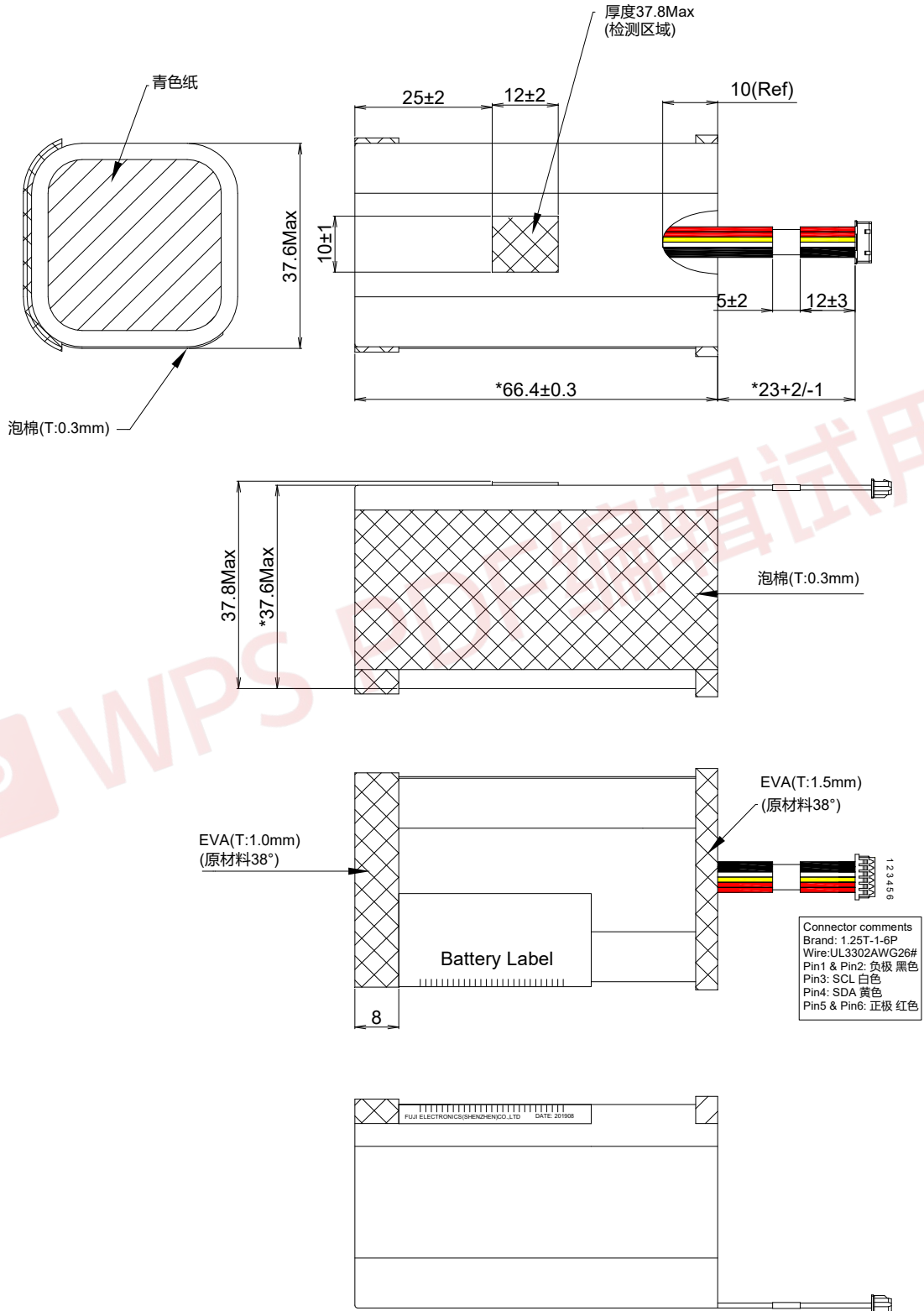



文件名称 File Name	电池规格书 Battery Spec.	产品型号 Product model	18650(11NR19/66-4)
文件编号 Document No.		文件版本 Version	A2
日期 Date	2021-05-12	页码 Page	14/ 18

7.2 商标图 Label drawing



S/N: F SW D 20 C 30 0001

S/N在条形码不扫读

流水号(0001~FFFF)

富基代码

日期(当月的天数)

电芯供应代码

月份(1=1月,9=9月.....A=10月,B=11月,C=12月)

D代表自动化生产,固定不变

年份(19=2019年.....99=2099年)

技术要求:

- 1、型号: 539043S商标
- 2、背胶型号: 溶剂性胶(CL51)
- 3、单(双)面背胶: 单面背胶
- 4、附着力: $\geq 0.8\text{Kg}$
- 5、包装要求: 无
- 6、外观: 印刷无重影, 残字及模糊不清
- 7、厚度: $0.1 \pm 0.05\text{mm}$
- 8、原材料: 合成纸(PG56)覆哑膜
- 9、颜色: 白底黑字
- 10、其它要求: 参考IQC商标检验标准

	文件名称 File Name	电池规格书 Battery Spec.	产品型号 Product model	18650(1INR19/66-4)
	文件编号 Document No.		文件版本 Version	A2
	日期 Date	2021-05-12	页码 Page	15/ 18

9、环保要求 Environmental requirements.

本电池产品符合 RoHS2.0 指令要求。

This product is RoHS2.0 compliant.

10、外观 Cosmetic requirements

10.1 用目测法检验被测电池外观，并检查电池与移动电话或模拟装置配合情况，应符合以下要求：

Visually inspect the battery appearance and check the fit between the battery and the mobile phone or simulator device. The result should be in conformance with the following requirements.

10.2 电池表面平整、清洁、无机械损伤；喷涂效果均匀、无色差；标签内容正确、字迹清晰、无遗漏、有相关标识，五金端子无锈蚀、镀金良好、无划伤变形。

The battery surface should be even, clean and free from mechanical damage; the spray painting effect should be even and no chromatic aberration; the text on label should be correct, clear and complete. Identifications and metal contacts should be well plated and free from rust, scratches and deformation.

10.3 电池成品表面应有必须的产品标识：含产品名称、型号、标称电压、容量、充电限制电压、执行标准编号、正负极性、序列号、制造厂名、商标和警告语等。

the surface of battery should bear necessary product identifications. These include product name, model, nominal voltage, capacity, maximum charge voltage, reference standard, positive and negative polarities, serial number, manufacturer's name, trademark, warnings, etc.

10.4 封装效果良好，间隙均匀、无明显溢胶，移动电话或模拟装置配机效果良好，拆卸顺利、锁扣可靠、开机能工作正常。

The battery is well sealed and margined, free from excess glue. The battery fits well with the mobile phone or simulator device. The battery can be inserted and removed smoothly. The latch is reliable. Battery shall function properly when the device is powered on.

11、运输、贮存 Transportation and storage

11.1 运输 Transportation

电池应包装成箱进行运输，在运输过程中应防止剧烈振动、冲击或挤压，防止日晒雨淋，严禁与易燃、易爆、易腐蚀的物品同车装运，可使用汽车、火车、轮船、飞机等交通工具进行运输。

The battery should be packaged into boxes for transportation. Excess vibration, shock, crush, direct sunlight and drenching should be avoided in transit. The battery must not ship together with things that are flammable, explosive or corrosive on the same vehicle. The battery can be transported on trucks, trains, ships, aircrafts or other transportation vehicles.

11.2 贮存 Storage

电池贮存应保持原有包装，存放产品仓库环境温度为-20℃~+25℃，相对湿度 45~75%RH 清洁、干燥、通风并设有防潮、防尘、防震、防腐蚀措施的室内，避免与腐蚀性物质接触，应远离火源及热源。

The battery should be kept in their original package and stored in a warehouse with ambient temperature in the range between -20℃ and +25℃, and relative humidity 45~75%RH. The battery should be kept indoors in a place that is clean, dry, ventilated and equipped with measures against moisture, dust, vibration and corrosion, and kept from contact with corrosive substance and sources of ignition and heating.

	文件名称 File Name	电池规格书 Battery Spec.	产品型号 Product model	18650(1INR19/66-4)
	文件编号 Document No.		文件版本 Version	A2
	日期 Date	2021-05-12	页码 Page	16/ 18

12、安全规程和使用说明 Safeguard and instruction

12.1 推荐使用事项 Recommendations

12.1.1 使用电池前，请仔细阅读使用说明书和电池表面标识。

Please read the instruction manual and the markings on the battery package carefully before using the battery.

12.1.2 请在正常的室内环境中使用电池：温度：23±2℃，相对湿度：45~75%RH。

Please use batteries in normal indoor environment with temperature of 23±2℃ and relative humidity of 45~75%RH.

12.1.3 在使用过程中，应远离热源、高压，避免儿童玩弄电池，切勿摔打电池。

Stay away from heating sources, high pressure when using the battery. Keep the battery out of reach of children. Do not strike the battery.

12.1.4 本电池只能使用配套充电器充电。不要将电池放在充电器中充电超过 24h。

Charge the battery with the specified charger only. Do not charge the battery in the charger for more than 24 hours.

12.1.5 长期不用时，请将电池储存完好。让电池处于 50% SOC，即不充满，也别放完。

Store the battery in a good condition when do not use for an extended period of time. Store the battery in 50% SOC.

This means do not completely charge and discharge the battery.

12.1.6 请用不导电材料包裹电池，以避免金属直接接触电池，造成电池损坏。将电池保存在阴凉干燥处。

Package the battery with non-conductive material to avoid direct contact with metal objects and resultant damage.

Store the battery in a cool and dry place

12.1.7 废弃电池请安全妥当处理，不要投入火中或水中。

Please dispose of depleted batteries in a safe and proper way. Do not throw the battery into fire or water.

12.2 危险警告 Warning

12.2.1 禁止拆装电电池。

内部具有保护结构和保护电路可以避免发生危险。不合适的拆装将会损坏保护功能，会造成电池发热、冒烟、变形或燃烧。

Do not disassemble or assemble the battery

Protection structures and circuits contained in the battery can prevent occurrence of dangers. Incorrect disassembling and assembling will damage the protection functions and cause heat generation, smoking, deformation or burning

12.2.2 禁止让电池短路。

不要将电池的正负极用金属连接，也不要将电池与金属放在一起存贮移动。如果电池被短路，将会有超大电流流过，将会损坏电池，造成电池发热、冒烟、变形或燃烧。

Do not short-circuit the battery

Do not connect the positive and negative terminals of the battery with metal object. Do not store and carry the battery together with metal objects. If the battery is short-circuited, the generated excessively large current may damage the battery and the short-circuit may also cause heat generation, smoking, deformation or burning.

12.2.3 严禁加热和焚烧电池

加热和焚烧电池将会造成电池隔离物的熔化，安全功能丧失或电解质燃烧。过热就会使电池发热、冒烟、变形或燃烧。

Do not heat or burn the battery

Heating or burning the battery will result in the melting of the battery separator, loss of safety protection functions or burning of electrolyte. Over-heat may lead to the battery heating, smoking, deformation or burning.



文件名称 File Name	电池规格书 Battery Spec.	产品型号 Product model	18650(11NR19/66-4)
文件编号 Document No.		文件版本 Version	A2
日期 Date	2021-05-12	页码 Page	17/ 18

12.2.4 避免在热源附近使用电池

不要在火源，烤炉附近或超过 80°C 的环境中使用电池，过热将会导致电池内部短路，使电池发热、冒烟、变形或燃烧。
Do not use the battery near a heat source, Do not use the battery near fire or an oven, or in an ambient temperature exceeding 80°C. Over-heat may cause internal short-circuit, heat generation, smoking, deformation or burning

12.2.5 禁止弄湿电池

不要弄湿电池，更不能将电池投入水中。否则会造成电池内部保护电路功能丧失和发生不正常的化学反应，电池有可能发热、冒烟、变形或燃烧。

Do not wet the battery

Do not wet the battery and do not throw it into water. Otherwise, it may damage the battery's circuit protection function, create abnormal chemical reaction, and even cause heating, smoking, deformation or burning.

12.2.6 避免在火源附近或阳光直射下充电

否则会造成电池内部保护电路功能丧失和发生不正常的化学反应，电池有可能发热、冒烟、变形或燃烧。

Do not charge the battery near the fire or in direct sunlight

Charging the battery in direct sunlight may destroy the battery's circuit protection function, create abnormal chemical reaction, and may even result in heat generation, smoking, deformation or burning.

12.2.7 使用专用充电器和正确充电

使用非专用充电器给电池充电，会发生危险。在不正常的条件下充电会造成电池内部保护电路功能丧失和发生不正常的化学反应，电池有可能发热、冒烟、变形或燃烧。

Charge the battery with a dedicated charger and charge correctly

If the battery is charged under abnormal conditions, it can destroy the battery's circuit protection function and create some abnormal chemical reaction. This may result in heat generation, smoking, deformation or burning.

12.2.8 禁止破坏电池

禁止用金属凿入电池，锤打或摔打电池，或其它方法破坏电池，否则会造成电池发热、冒烟、变形或燃烧，甚至会发生危险。

Do not damage batteries

Do not damage the battery by driving in a piece a metal, hammering, striking or by other means, otherwise it can result in heat generation, smoking, deformation or burning.

12.2.9 禁止在电池上直接焊接

过热将会造成电池隔离物的熔化，安全保护功能丧失，使电池发热、冒烟、变形或燃烧。

Do not solder directly on batteries

Overheat will cause the melting of the battery separator, failure of safety protection functions. This may result in heat generation, smoking, deformation or burning

12.2.10 严禁将电池直接接在电源插座或车载点烟器上充电

高压、大电流将会流过电池而使其损坏，或使电池发热、冒烟、变形或燃烧。

Do not plug the battery directly into a power supply socket or automobile cigarette lighter.

High voltage or excess current will run through and damage the battery. This may cause heat generation, smoking, deformation or burning.



文件名称 File Name	电池规格书 Battery Spec.	产品型号 Product model	18650(11NR19/66-4)
文件编号 Document No.		文件版本 Version	A2
日期 Date	2021-05-12	页码 Page	18/ 18

12.2.11 不可将电池用于其它设备

不合适的使用条件会损坏电池的性能，降低寿命，甚至会使电池发热、冒烟、变形或燃烧。

Do not use batteries to power other devices

Unusual operating conditions may damage the battery performance, reduce life cycle and even cause heat generation, smoking, deformation or burning.

12.2.12 不要直接接触漏液电池

渗漏的电解液会造成皮肤不适。万一电解液进入眼睛，尽快用清水冲洗，不可揉眼，并迅速送医院处理。

Do not make direct contact with leaking batteries

The leaked electrolyte may cause skin irritation. If electrolyte gets into your eyes, rinse your eyes with fresh water immediately. Do not rub your eyes and immediately go to hospital for medical attention.

13、质量评定程序 Quality Assessment Procedures

质量检验分为鉴定检验和质量一致性检验。

鉴定检验一般在设计定型、更改设计和生产定型时进行。抽样方案、检验项目、顺序以及判定规则等事宜由供需双方协商确定。原则上应包括以上各项性能试验。质量一致性检验分为逐批检查和周期检查，用以判定产品生产过程中能否合格保证产品质量的持续稳定。可以参照 GB2828.1-2003、GB2829-2002 标准执行。具体抽样方案、检验项目、顺序以及判定规则等事宜由供需双方协商确定。原则上，逐批检查的检验项目应包括外观、内阻、额定容量或 1C₅A 放电容量等。

Quality inspection is divided into identification inspection and quality conformance inspection.

Identification test is generally conducted in the design approval, change of design and production. Sampling scheme, inspection items, inspection sequence, rules of judgment, etc. should be determined by consultation between the supplier and the customer. In principle, all the tests aforementioned should be included. Quality conformance inspection is divided into lot by lot inspection and periodic inspection. These inspections are used to judge whether the production process can ensure the sustaining stability of product quality. Refer to national standard GB2828.1-2003 and GB2829-2002 for implementation. Specific sampling scheme, inspection items, inspection sequence, rules of judgment, etc. should be determined by consultation between the supplier and the customer. In principle, the lot-by-lot inspection items should include appearance, internal impedance, rated capacity or 1 C₅A discharge capacity.

14、保质期限 Guaranteed Deadline

保质期限从出厂日期开始算 12 个月

Guaranteed Deadline of this product is 12 months from manufacture code

15、其他事项 Miscellaneous

以上所述，可以作为供需双方对电池产品性能和检验规则的约定框架。如果没有新的书面约定或更改通知，即可按此执行。

The aforementioned could be used as agreed framework by both parties for battery performance and inspection specifications. It should be implemented if there is no new written agreement or change notice