

**JOHN DEERE**  
**WORLDWIDE COMMERCIAL & CONSUMER**  
**EQUIPMENT DIVISION**

---

**Utility Cart**  
**10P**

**OMM155001 E6**

**OPERATOR'S MANUAL**



**JOHN DEERE**

All information, illustrations and specifications in this manual are based on the latest information at the time of publication. The right is reserved to make changes at any time without notice.

**COPYRIGHT© 2006**  
Deere & Co.

John Deere Worldwide Commercial and Consumer Equipment Division  
All rights reserved  
Previous Editions  
**COPYRIGHT© 2005**

North American Version  
Litho in U.S.A.

# PRODUCT IDENTIFICATION

## Product Identification

### Product Compatibility

This utility cart is designed for use with lawn tractors and lawn and garden tractors.

### Record Purchase Information

#### Utility Carts

Model 10P

Record your purchase information in the spaces provided below.

DATE OF PURCHASE:

DEALER NAME:

DEALER PHONE:

## Safety Labels



### Understanding The Machine Safety Labels

The machine safety labels shown in this section are placed in important areas on your machine to draw attention to potential safety hazards.

On your machine safety labels, the words DANGER, WARNING, and CAUTION are used with this safety-alert symbol. DANGER identifies the most serious hazards.

The operator's manual also explains any potential safety hazards whenever necessary in special safety messages that are identified with the word, CAUTION, and the safety-alert symbol.

### CAUTION



MX17871a

TO HELP PREVENT BODILY INJURY DUE TO LOSS OF STABILITY OR CONTROL

- Do not exceed maximum towing capacity of towing vehicle listed in the vehicle operator's manual.
- Do not exceed maximum cart load capacity listed in cart operator's manual.

- Reduce loaded cart weight on slopes and/or slippery surfaces.
- Do not exceed 8 mph (13 kph) when towing cart.

## Safety

Read the general safety operating precautions in your machine operator's manual for additional safety information.

### Operate Safely

- This attachment is intended for use in lawn care and home applications. Do not tow behind a vehicle on a highway or in any high speed application. Do not tow at speeds higher than maximum recommended towing speed.
- Towing speed should always be slow enough to maintain control. Travel slowly over rough ground.
- Do not let children or an untrained person operate machine.
- Do not let anyone, especially children, ride on machine or attachment. Riders are subject to injury such as being struck by foreign objects and being thrown off. Riders may also obstruct the operator's view, resulting in the machine being operated in an unsafe manner.
- Check machine brake action before you operate. Adjust or service brakes as necessary.
- Keep all parts in good condition and properly installed. Fix damage immediately. Replace worn or broken parts. Replace all worn or damaged safety and instruction decals.
- Do not modify machine or safety devices. Unauthorized modifications to the machine or attachment may impair its function and safety.
- Securely anchor all loads to prevent loads from falling.

### Towing Loads Safely

- Stopping distance increases with speed and weight of towed load. Travel slowly and allow extra time and distance to stop.
- Total towed weight must not exceed limits specified in towing vehicle operator's manual.
- Excessive towed load can cause loss of traction and loss of control on slopes. Reduce towed weight when operating on slopes.
- Never allow children or others in or on towed equipment.
- Use only approved hitches. Tow only with a machine that has a hitch designed for towing. Do not attach towed equipment except at the approved hitch point.
- Follow the manufacturer's recommendations for weight limits for towed equipment and towing on slopes. Use counterweights or wheel weights as described in the machine operator's manual.
- Do not turn sharply. Use additional caution when turning or operating under adverse surface conditions. Use care when reversing.
- Do not shift to neutral and coast downhill.

### Protect Bystanders

- Keep bystanders away when you operate a towed attachment.
- Before you back machine and attachment, look carefully behind attachment for bystanders.

# SAFETY

---

---

## **Keep Riders Off Towed Attachment**

Keep riders off of a towed attachment.

Riders on a towed attachment are subject to injury, such as being struck by objects and being thrown off the attachment during sudden starts, stops and turns.

Riders obstruct the operator's view, resulting in the attachment being used in an unsafe manner.

Keep riders off of hitch bracket.

## **Keep Feet From Under Drawbar**

Before you disconnect an attachment from machine hitch plate:

- Unload attachment.
- Stop attachment on level ground.
- Stop machine engine.
- Lock machine park brake.
- Block attachment wheels.
- Make sure feet are not under drawbar.

# ASSEMBLY

## Assembly

### Parts in Kit

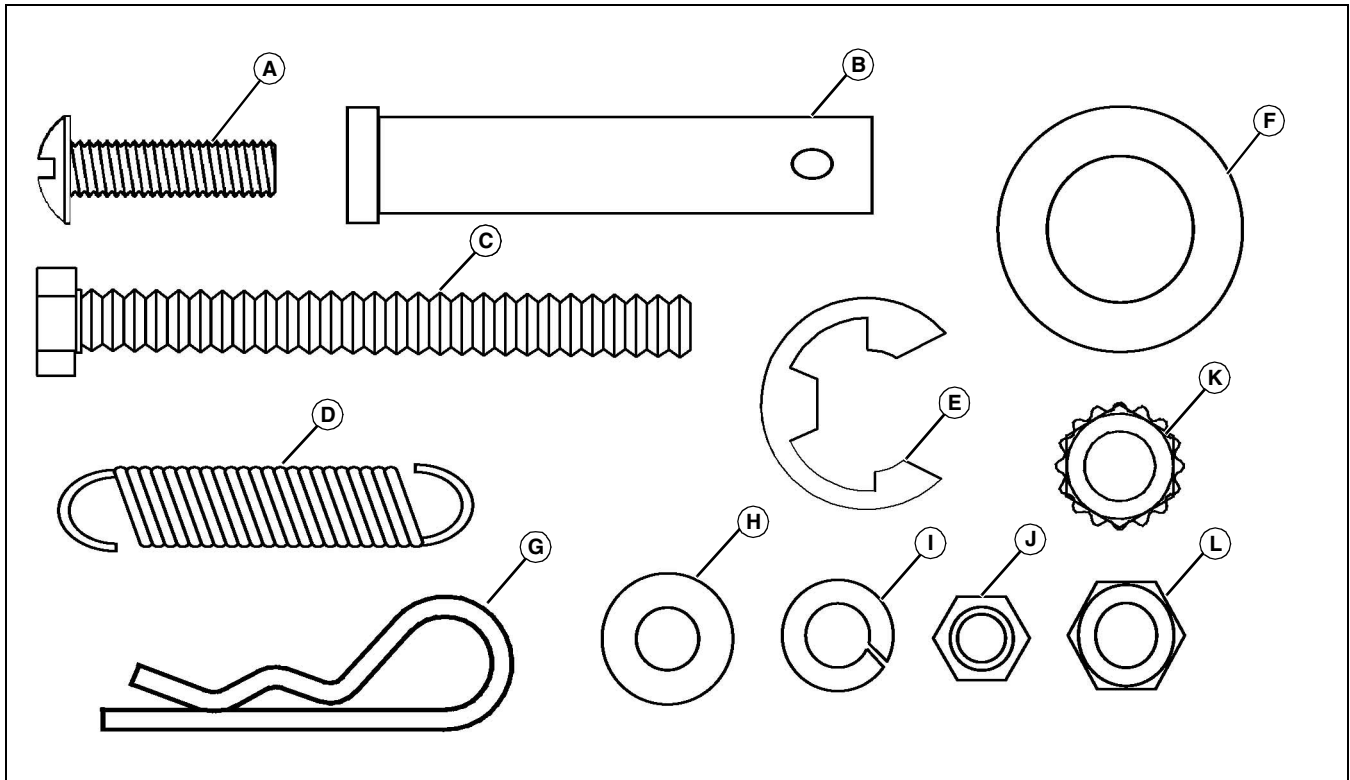

MX23100a

#### Bag of Parts (Hardware)

Qty.	Description
12	Slotted Head Screw, 5/16 x 1 in. (A)
1	Clevis Pin, 1/2 x 2-1/2 in. (B)
1	Bolt, 3/8 x 3-3/4 in. (C)
1	Spring, Latch (D)
2	Retaining Ring, 3/4 in. (E)
4	Bushing, 3/4 in. (F)
1	Spring Locking Pin, 1/8 in. (G)
10	Washer, Flat, 5/16 in. (H)
12	Lockwasher, 5/16 in. (I)
12	Nut, 5/16 in. (J)
2	Nut, w/Star Washer, 3/8 in. (K)
1	Locknut, 3/8 in. (L)

#### Parts in Kit (Not Shown)

Qty.	Description
1	Cart
1	Lock Bracket
1	Axle Support
1	Axle
2	Wheel
1	Drawbar
1	Lock Bar
1	Clevis

#### Tools Required

##### Tools required for assembly:

- 1/2 in. wrench (2)
- 9/16 in. wrench (2)
- Pliers
- Flat blade screwdriver

# ASSEMBLY

## Assemble Cart

When assembling cart, do the following

- Do not discard cardboard bed divider, it can be used as a template for making dividers for the cart.
- Place pieces of carton under cart box to help avoid scratching finish.
- Put all bolt heads to the inside of the cart box.

## Install Axle Support

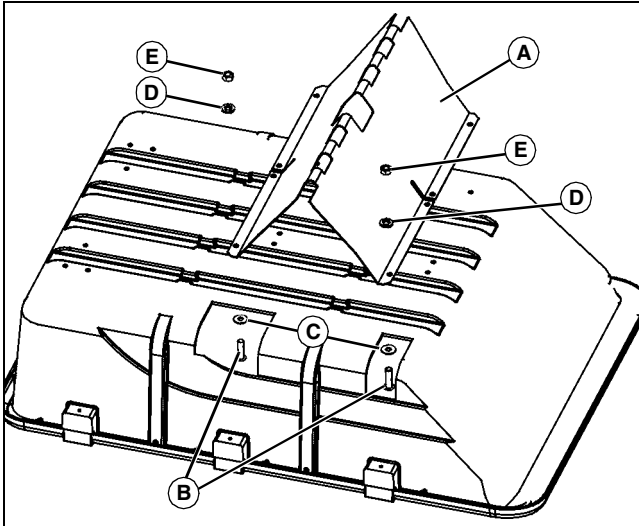

MX36393

1. Place axle support (A) on bottom of cart.
2. Install eight 5/16 x 1 in. slotted head screws (B) and eight 5/16 in. flat washers (C), from inside cart box through axle support. Place eight 5/16 in. lockwashers (D) and eight 5/16 in. nuts (E) on screws.
3. Tighten nuts.

## Install Lock Bracket

**NOTE:** Make sure notch on lock bracket is facing to the front of the cart.

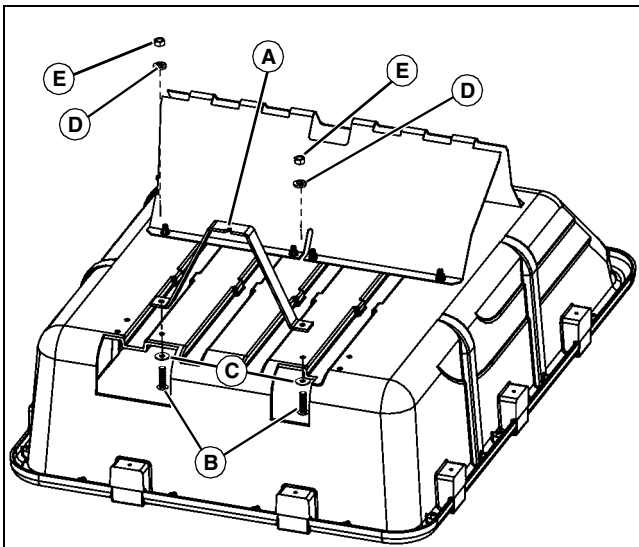

MX36394

1. Place lock bracket (A) on cart.
2. Install two 5/16 x 1 in. slotted head screws (B) and two 5/16 in. flat

washers (C) through cart box (from inside cart box) and lock bracket.

3. Secure with two 5/16 in. lockwashers (D) and two 5/16 in. nuts (E).
4. Tighten nuts.

## Assemble Cart Lock Bar

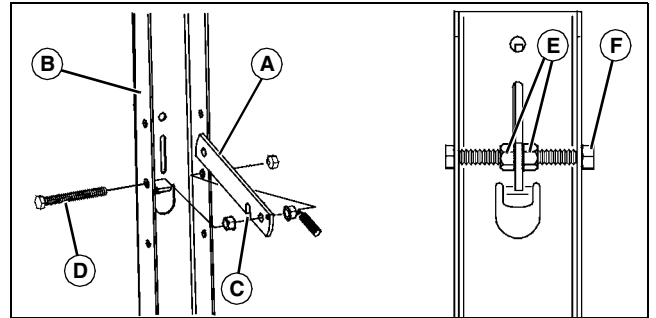

MX36395

**Picture Note:** Bottom of drawbar shown

1. Place cart lock bar (A) through slot in drawbar (B) with notch (C) in lock bar to rear of cart.

**NOTE:** Locknuts with attached star washers should be installed on each side of the cart lock bar so it is centered.

**Pull up on lock bar while installing bolt. This will help to align the bolt with the hole on the other side of the drawbar.**

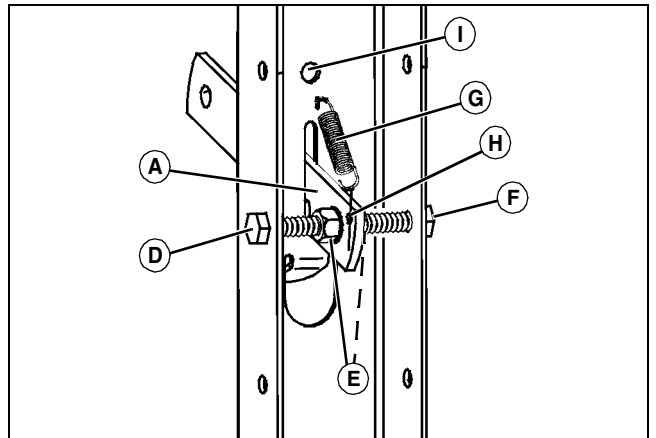

MX36396

2. Install one 3/8 x 3-3/4 in. bolt (D) and two 3/8 in. nuts with attached star washers (E) through drawbar and lock bar.
3. Tighten nuts securely
4. Secure bolt with 3/8 in. locknut (F) so lock bar moves forward and backward freely.
5. Hook one end of spring (G) in hole (H) in lock bar (A); stretch spring to hook other end in cart drawbar hole (I).

# INSTALLING

## Install Clevis

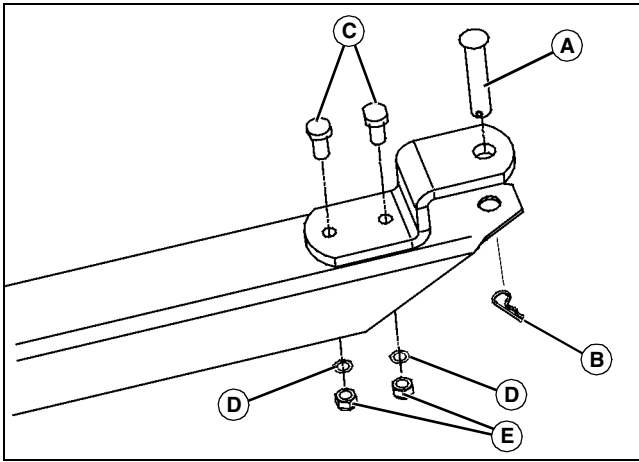

MX36397

1. Place clevis pin (A) on cart drawbar. Secure with 1/8 in. spring locking pin (B).
2. Install two 5/16 x 1 in. slotted head screws (C) through clevis and cart drawbar.
3. Fasten with two 5/16 in. lockwashers (D) and two 5/16 in. nuts (E).
4. Tighten nuts.

## Install Cart Drawbar and Wheels

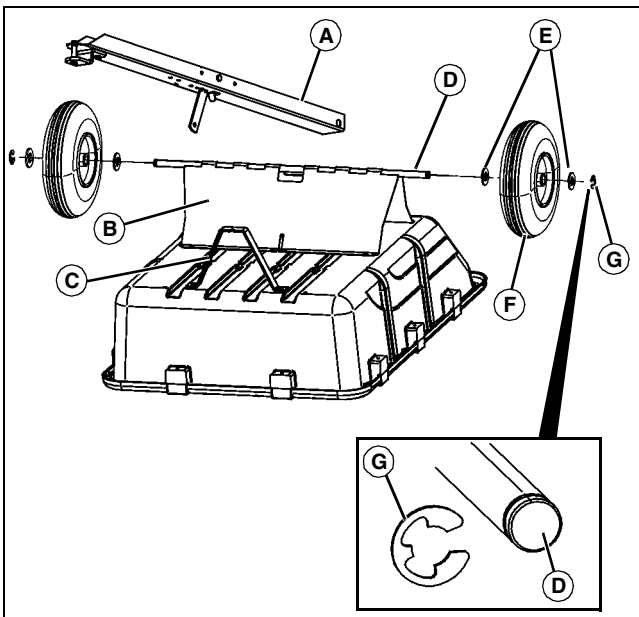

MX36398

1. Place drawbar (A) on axle support (B) and lock bracket (C).

**NOTE:** A light coating of grease or oil on axle will aid in inserting the axle through the axle support.

2. Slide axle (D) through axle support and drawbar.
3. Slide one 3/4 in. bushing (E) on both axle ends.

**NOTE:** Put a small amount of grease on each end of axle, before installing wheels. This will make installing wheels on axle easier.

4. Put one wheel (F) (valve stem to the outside) on axle.
5. Put second 3/4 in. bushing (E) and one retaining ring (G) on axle.

6. Repeat steps for other wheel.
7. Inflate tires to correct tire pressure.
8. Grease wheel bearings with John Deere multipurpose grease or an equivalent.

## Installing

### Installing Cart



**CAUTION:** Avoid injury! Before installing cart, make sure dump lever is locked in place.

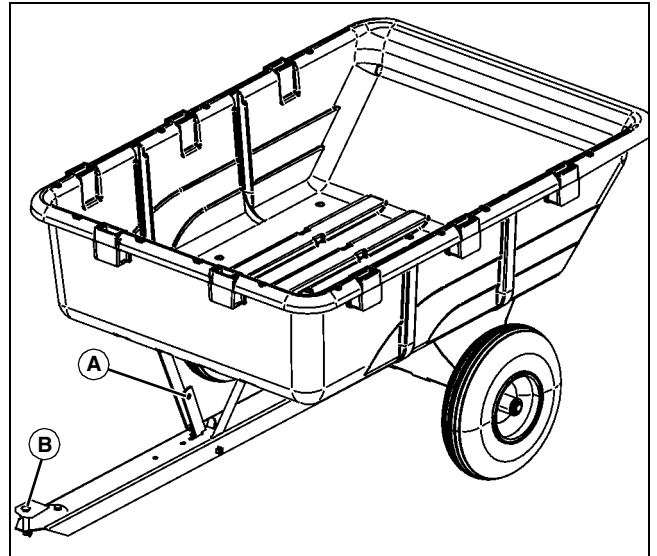

MX36820

1. Lock cart lock bar (A) in place.
2. Park machine safely. (See Parking Safely in the Safety section.)
3. Align cart drawbar with machine drawbar.
4. Install clevis pin (B) through cart drawbar and machine drawbar. Secure clevis pin with 1/8 in. spring locking pin.

## Removing

### Removing Cart



**CAUTION:** Avoid injury! Before installing cart, make sure transport latch is facing toward cart dump lever and dump lever is locked in place.

**NOTE:** Refer to illustrations in the Installing Section, earlier in this manual.

1. Park machine safely. (See Parking Safely in the Safety section.)
2. Unload cart.

# OPERATING



**CAUTION: Avoid injury! Keep feet away from under drawbar.**

3. Remove cotter pin and drawbar pin.
4. Push cart away from machine. Block cart wheels.
5. Install drawbar pin and cotter pin in cart drawbar for storage.

## Operating

### Determining Weight for Cart



**CAUTION: Avoid injury! Excessive towed load can cause loss of traction and loss of control on slopes. Stopping distance increases with speed and weight of towed load.**

**Total towed weight must not exceed combined weight of pulling machine, ballast and operator.**

The following maximum loaded cart weight capacities are the average weight of each cart model loaded with dry sand leveled with the top of the cart.

Model Cart	Loaded Weight Capacity
10P	327 kg (722 lb)



**CAUTION: Avoid injury! If additional weight is required when towing a cart, add weight at or forward of the rear wheels. Adding weight behind the rear wheels can affect machine steering.**

Towing cart capacity will vary with weight of towing machine and operator. Add the weight of your machine to operator weight to find the maximum capacity of the towing cart.

With all cart usage, the cart load should be reduced when operating on slopes or slippery surfaces to maintain stability.

#### Example:

If Towing Machine Weighs:	225kg (500 lb)
Add Your Weight:	90kg (200 lb)
Combined Weight Equals	315kg (700 lb)

To maintain stability using the cart in this example, you cannot safely carry more than 315 kg (700 lb) without first adding additional ballast to the towing machine.

### Unloading Cart

1. Park machine safely. (See Parking Safely in the Safety section.)



**CAUTION: Avoid injury! Before dumping cart:**

- Park machine safely.
- Before backing up, make sure area is clear of bystanders, especially children.
- Make sure cart is installed to the towing machine.

2. Move cart lock bar forward to release cart box.

3. Tilt cart box back to unload cart.
4. Push cart down and move cart lock bar toward cart and lock into place.

## Service

### Lubricating Wheel Bearings

Lubricate each wheel bearing with John Deere multipurpose grease or an equivalent.

## Specifications

### Model 10P Cart

Maximum Towing Speed	13 kph (8 mph)
Box Capacity (Heaped)	.28m <sup>3</sup> (10 cu ft)
Maximum Load	295kg (650 lb)
Maximum Tongue Weight	32kg (70 lb)
Empty Weight	33kg (72 lb)

### Tires

Size	15.00x6-6
Inflation Pressure	97kPa (14 psi)

## Getting Quality Service

### John Deere Quality Continues with Quality Service

John Deere provides a process to handle your questions or problems, should they arise, to ensure that product quality continues with quality parts and service support.

Follow the steps below to get answers to any questions you may have about your product.

1. Refer to your attachment and machine operator manuals.
2. In North America or Canada, call John Deere Special Services at 1-866-218-8622 and provide product serial number (if available) and model number.

# NOTES

---

---