

INSTALLATION AND OPERATING INSTRUCTIONS

Children's electric cars

⚠ WARNING:

Assembly by an adult.

This toy is unsuitable for children under
3 years due to its maximum speed.

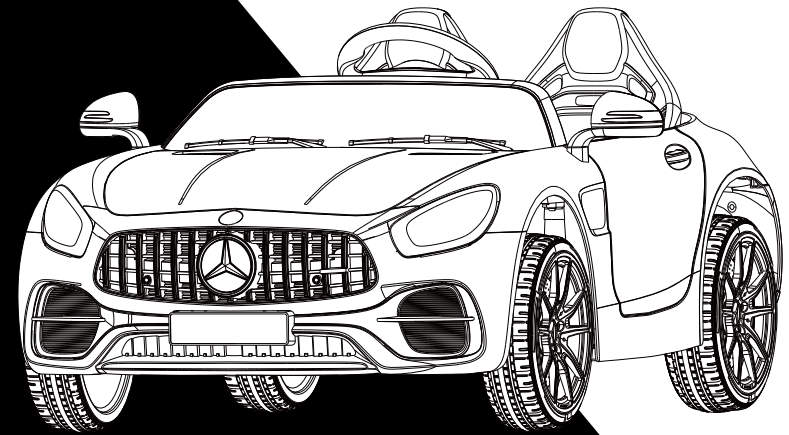

Executive standard:
En71 and En62115
ASTM F963-17

Photos are for reference ONLY.

INSTALLATION INSTRUCTION

The illustrations in this instruction are used for easier understanding of the operation method of the product and the product structure. Please note there may be differences between the pictures and the physical item.

In order to improve the quality, we may change part of the structure and appearance of the product without an advance notice.

⚠ Please read the instructions carefully before use, it will tell you the right operation method and installation steps. Incorrect operation may damage the product, or even hurt your child. Please keep this instruction ready and easy to find.

1 Safety

⚠ WARNING!

The owner's manual contains assembly, use and maintenance instructions. The vehicle must be assembled by an adult who has read and understands the instructions in this manual. Keep the pack-aging away from children and dispose of all packaging before use.

Note: For best performance use on flat, hard surfaces.

The following safety hazards may result in serious injury or death to the user of the vehicle:

- This product contains small parts that are for adult assembly only. Keep small children away when assembling. Remove and dispose of all protective material and poly bags before assembly. Be sure to remove all packaging materials and parts from underneath the vehicle body.
- Battery posts, terminals and related accessories contain lead and lead compounds (acids) chemicals known to the state of California to cause cancer, reproductive harm, and are toxic and corrosive. Never open the battery.
- Body parts such as hands, legs, hair and clothing can get caught in moving parts. Never place a body part near a moving part or wear loose clothing while using the vehicle. Always wear shoes when using the vehicle.
- This toy does not have brakes or any braking capability. Do not leave a child unattended while using this toy or allow use of this toy in any location that requires braking capability, as this could result in a roll away or loss of control, which may cause serious injury or death.
- Using the vehicle near streets, motor vehicles, drop-offs such as: steps,

water (swimming pools) or other bodies of water, sloped surfaces, hills, wet areas, flammable vapors, in alleys, at night or in the dark could result in an unexpected accident. Always use the vehicle in a safe, secure environment with continuous adult supervision.

- Using the vehicle in unsafe conditions such as snow, rain, loose dirt, mud, sand or fine gravel may result in unexpected action such as tip over and skidding, and damage to the electrical system and battery.
- Using the vehicle in an unsafe manner. Examples include but are not limited to:
 - a. Pulling the vehicle with another vehicle or similar device
 - b. Allowing more than one rider
 - c. Pushing the user from the back
 - d. Traveling at an unsafe speed

Always use common sense and safe practices when using the vehicle

BATTERY WARNINGS

⚠ WARNING!

The following safety hazards may result in serious injury or death to the user of the vehicle:



- Use of a battery or charger other than the supplied 12V rechargeable battery and charger may cause a fire or explosion. Only use the supplied 12V rechargeable battery and charger with the vehicle.

- Using the 12V rechargeable battery and charger for any other product may result in overheating, fire or explosion. Never use the 12V rechargeable battery and charger with another product.

- Explosive gases are created during charging. Charge the battery in a well ventilated area. Do not charge the battery near heat or flammable materials.

- Contact between the positive and negative terminals may result in fire or explosion. Avoid direct contact between the terminals. Picking up the battery by the wires or charger can cause damage to the battery and may result in a fire. Always pick up the battery by it's case or handles.



- Liquids on the battery may cause fire or electric shock. Always keep all liquids away from the battery and keep the battery dry.



- Contact or exposure to battery leakage (lead acid) may cause serious injury. If contact or exposure occurs immediately call your physician. If the chemical is on the skin or in the eyes, flush with cool water for 15 minutes. If the chemical was swallowed,

immediately give the person water or milk. Do not give water or milk if the patient is vomiting or has a decreased level of alertness. Do not induce vomiting.

- Battery posts, terminals and related accessories contain lead and lead compounds (acid), chemicals known to the State of California to cause cancer, reproductive harm and are toxic and corrosive. Never open the battery.
- Tampering or modifying the electric circuit system may cause a shock, fire or explosion and permanently damage the system. Exposed wiring, circuitry in the charger may cause electric shock. Always keep the charger housing closed.



USER REQUIREMENTS AND WARNINGS

Age	37-96 months
Max Weight	(40 kgs)

Before using the vehicle the child should understand the vehicle controls and safety issues. They must also demonstrate the capability to handle the vehicle and operate its controls. It is the responsibility of the adult to educate the child and supervise the vehicles use. Read the following safety warnings to any child using the vehicle before riding.

⚠ WARNING!

- Never leave child unattended. Always supervise the child.
- Always sit in the seat when using the vehicle.
- Keep your hands, hair and clothes away from moving parts.
- Always wear shoes when using the vehicle.
- Two riders are allowed on the vehicle at a time.
- Children under 3 years of age cannot use the vehicle.
- Only drive on level ground.
- Do not go near swimming pools or other bodies of water, drop-offs or up and down steep inclines.
- Do not drive the vehicle into loose dirt, mud, sand or fine gravel.
- Do not drive the vehicle on streets or near cars.
- Not to be used in traffic.

CARE WARNINGS

⚠ WARNING!

- Park the vehicle indoors or cover it with a tarp to protect it from wet weather.
- Do not leave the vehicle in the sun for long periods of time or fading may occur. Store in shade or cover with tarp.
- Do not wash the vehicle with a hose.
- Do not wash the vehicle with soap and water.
- Pay attention while driving the vehicle, avoid falls or collisions causing injury to the user or third parties.
- Please check the component parts before using, and make regularly examine the transformers or battery chargers for in the event of any damage on the cord, plug, enclosure and other parts, the vehicle shall not be used until the damage has been repaired, to avoid an accident.

RE-CHARGE INTERVAL AND TIME Important!







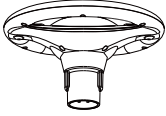

- Damage to the battery may occur if it is allowed to drain completely. Do not allow the battery to drain completely.
- Check the battery and charger (supply cord, connector) for wear and damage before charging. Do not charge the battery if damage has occurred.
- On average you will need to charge the battery between 8 and 12 hours. Do not charge the battery for more than 20 hours. Failure to charge the battery as directed could cause permanent damage to the battery and void the warranty.
- Only an adult who has read and understands the safety warnings should handle, charge and recharge the battery.

Specification

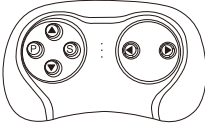
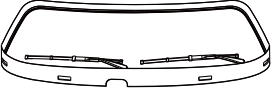
Name	specification
Battery	Battery: 12V 4.5AH(6-FM-4.5 (AH))*1 12V 7AH(6-FM-7 (AH))*1
Motor	Motor: 12V*2 Steering motor:12V*1
Suitable age	37-96 months
Maxweight	40KG
Body size	1210*670*400MM
Speed	3-6KM/h
Hours of use	charging8-12hours, using1to2hours
Charger	Input: 110V~240V Output: DC 12V500mA 12V1000mA
Mainmaterial	PP(polypropylene) and iron

*The above parameters contain optional features, specific parameters please refer to our samples.

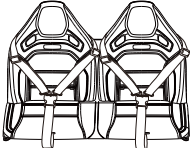
Parts List

NO	QTY	PICTURE	NO	QTY	PICTURE
①	1	 A (Steering Wheel)	②	1	 B (Instruction Book)
③	1 (optional)	 E (Remote control)	④	1	 F (Rearwing)
⑤	4	 H (Small Wheel Cover)	⑥	4	 J (Wheel)
⑦	1	 L (Mirror L)	⑧	1	 R (Mirror R)
⑨	1	 N (Seat)	⑩	2	 P (M8 Spanner)
⑪	2	 X (self-tapping screw)			

*Photos are for reference ONLY.

Installation Steps

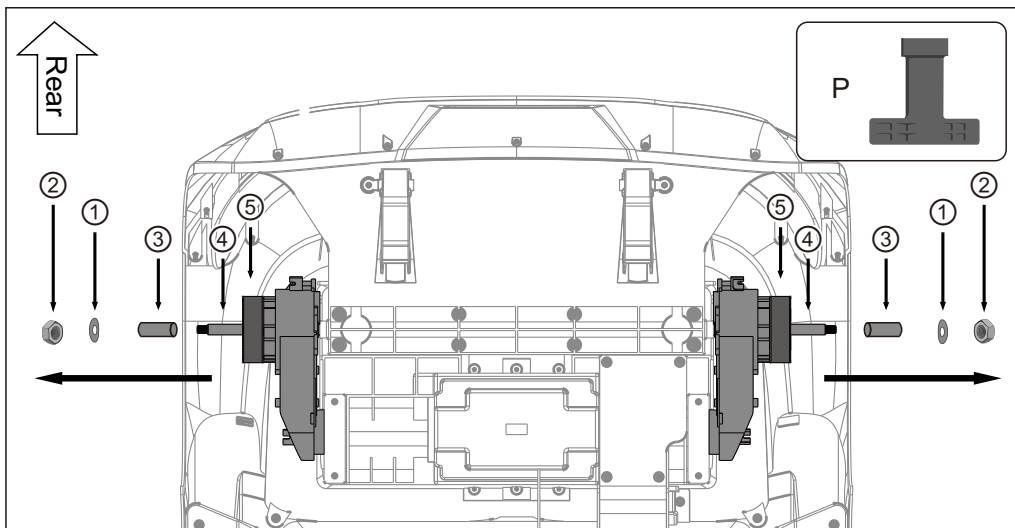

Step 1: Install the rear wheel

1. Use the P (M8 spanner) to loosen the ② (M8 screw) ① (M8 gasket) and ③ (Circular paper tube) from the ④ (rear axle) in a counterclockwise direction. (pay attention, keep the ⑤ at rear axle, avoid fall off).

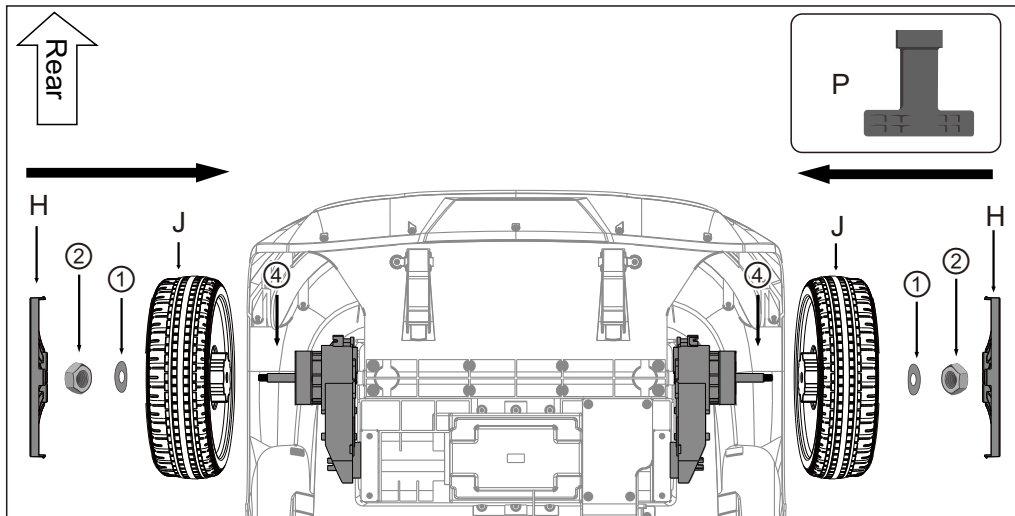

Step 1: Install the rear wheel

2. Install the J (wheel) onto the ④ (rear axle) follow the arrow direction, put the ① (M8 gasket), then use the P (M8 spanner) to tighten the ② (M8 screw) in clockwise direction. Finally install the H (wheel cover) on correct position (align and press the buckle of the wheel cap with the grooves of the wheel to fix it).

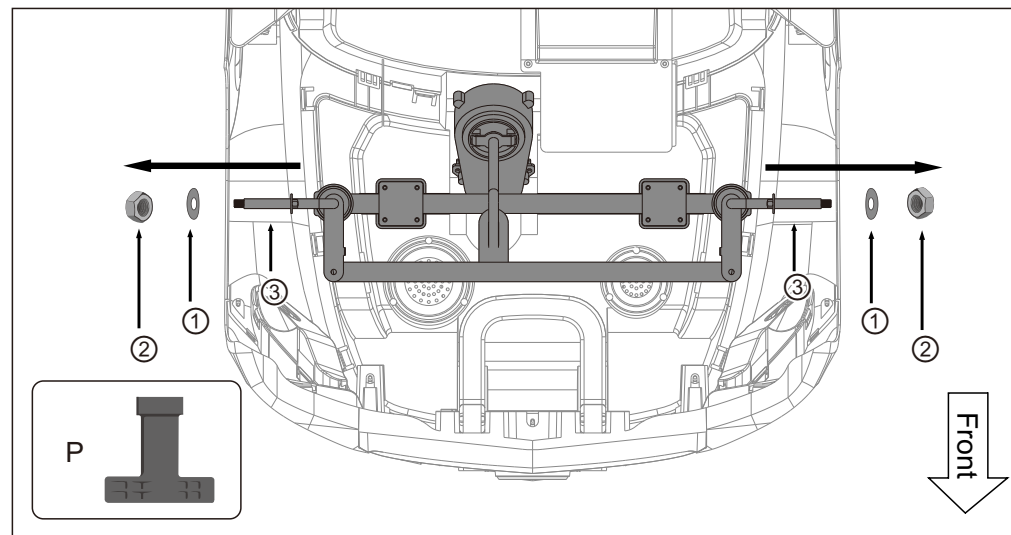

Step 2: Install the front wheel

Use the P (M8 spanner) to loosen the ② (M8 screw) ① (M8 gasket) from the ③ (rear axle) in a counterclockwise direction.

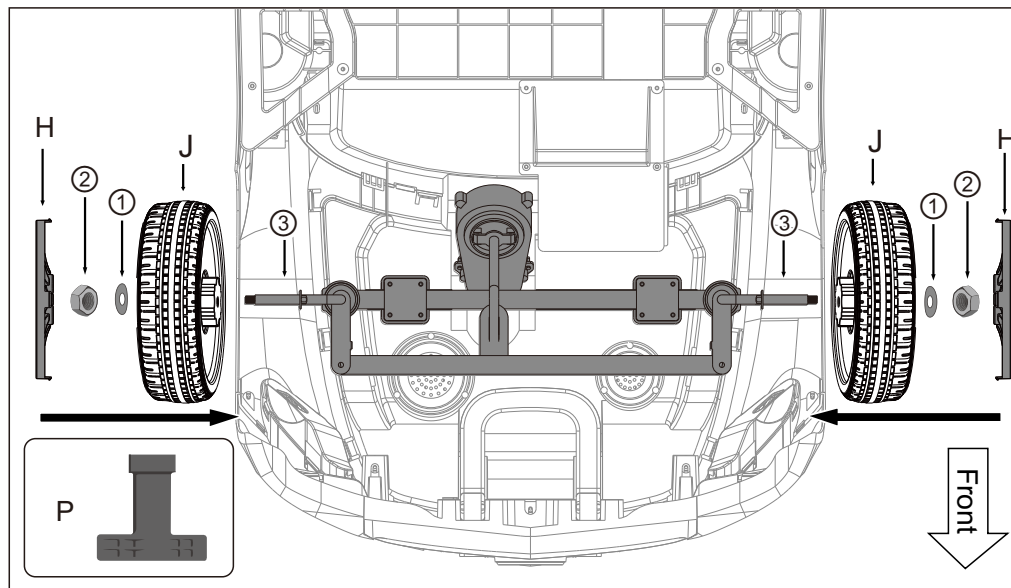

Step 2: Install the front wheel

Install the J (wheel) onto the ③ (front axle) follow the arrow direction, put the ① (M8 gasket), then use the P (M8 spanner) to tighten the ② (M8 screw) in clockwise direction. Finally install the H (wheel cover) on correct position (align and press the buckle of the wheel cap with the grooves of the wheel to fix it).

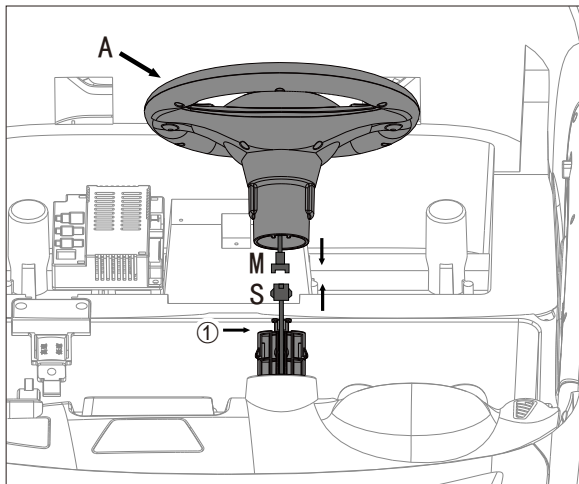

Step 3: Install the steering wheel

Connect S, M terminal firstly, then align the correct position and press A (steering wheel) on (steering yoke) as shown in figure.

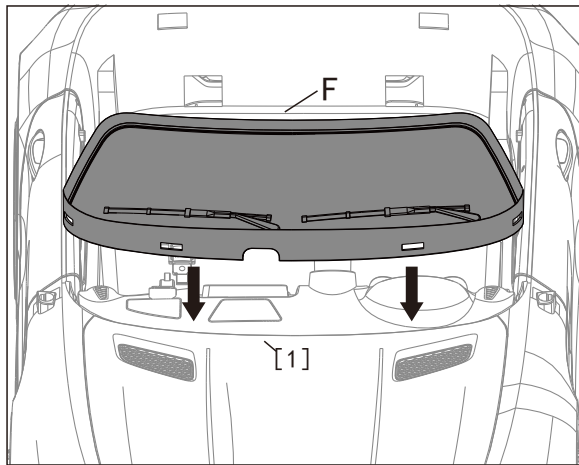

Step 4: Install the wind deflector

Place of F (wind deflector) onto the corresponding groove of car body as shown in figure, press down smoothly.

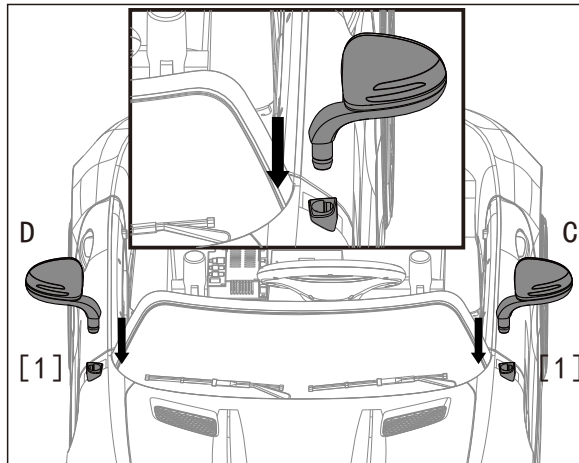

Step 5: Install the rear window

Align and press the C (rear window L), D (rear window R) with the [1] car body in correct placement as show in figure.

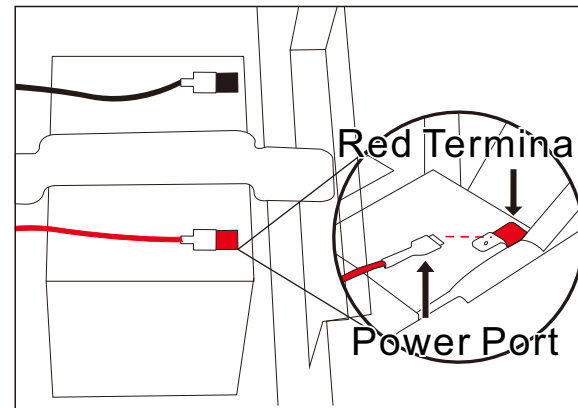

Step 6: connect the power

Remove the plastic cover from the red terminal (attention: put it at the safe place where far from the children to prevent the risk of asphyxiation), Find the positive electrode (the red port showed by arrow in figure), connect power port to the red terminal.

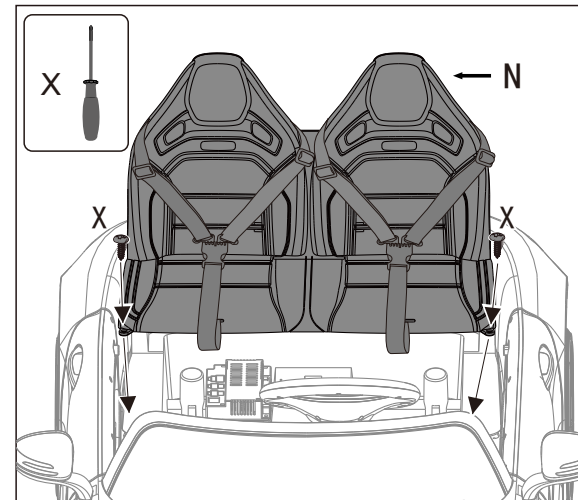

Step 7: Install the seat

Put the N (seat) onto the right place, fix the two hooks (at the back of the seat) into the corresponding groove on car body (press hardly till you hear it clack). then fix the N (seat) with 2pcs X (self-tapping screw) as shown in figure.

Direction for use

1. The installation and replacement of the batteries in the remote control:

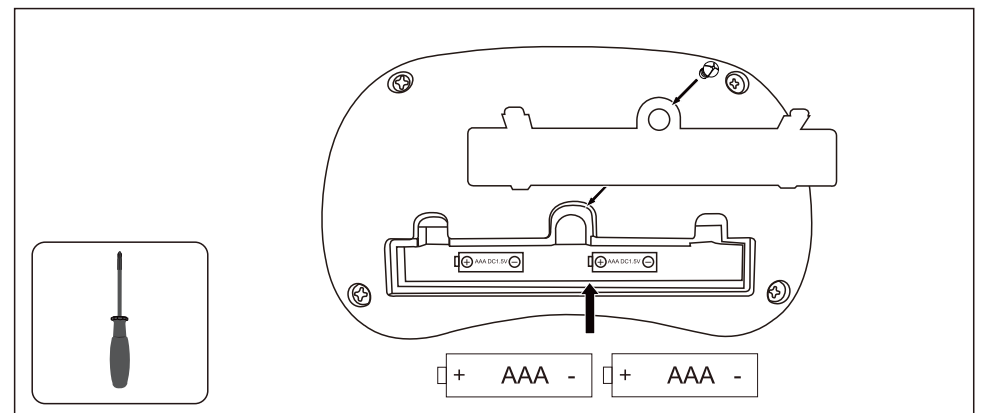

⚠ WARNING!

- 1.All batteries should be inserted in the correct polarity.
- 2.Non-rechargeable battery cannot be recharged
- 3.Before charging, the rechargeable battery must be taken out from the toys.
- 4.Take out and properly deal with the dead battery. To avoid injury, please keep kids away from the battery.
- 5.The direct contact between the positive and negative terminals may result in fire or explosion. Avoid direct connect between the terminals.
- 6.Do not mix old and new batteries.DO not mix alkaline, standard(carbon-zinc),or rechargeable(nickel-cadmium) batteries.
- 7.Only an adult who has read and understood the safety warnings can recharge the battery.

Use a screwdriver to remove the battery cover of the remote control, insert two AAA 1.5V dry batteries in correct polarity. Close the battery cover and fix it with the screw. (Battery replacement also according to the above steps)

2. Matching the frequency of car and remote control

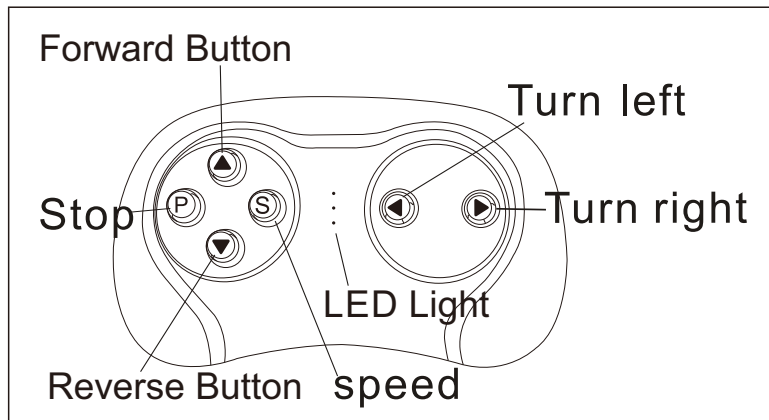

The remote control operation always prior to the foot pedals operation.(The foot pedal won't work whileoperating remote control)

Operation manual: For the first time to use(Or Replace the battery) Need to frequency bind

- Turn off the Power switch on the car.
- Remove the battery cover on the Remote Control and put in 2 AAA battery, the three LED indicators will flash.
- Turn on the Power Switch on the car, when the LED indicators stop flashing and 2 of them are on, matching successes.

- If the matching is failed (the three LED indicators flashing), please remove the battery and repeat steps 1-3.
- Button Description: △ forward ▽ backward ◀ turn left ▶ turn right
- S: Speed P:emergency brake, press it and the running function will fall, press again, it release

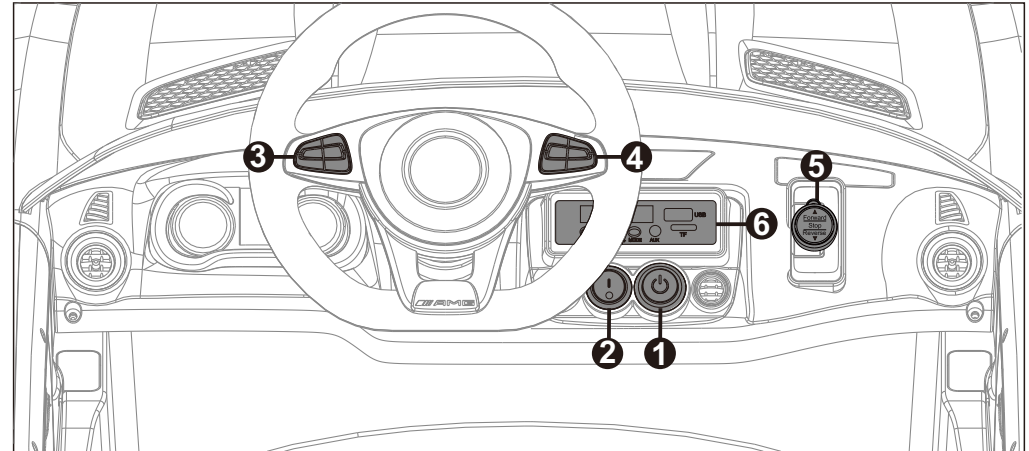

1. Power switch: Turn on or turn off the power.
2. Light switch: I is turn on, O is turn off.
3. Music button: press the button to play music.
4. Horn button: press the button to play the horn.
5. Forward/stop/backward switch: press the button for controlling the Vehicle to move forward, stop or backward.
6. Mp3 multifunctional player

3.Operation guide for Manual control (forward, backward):

After the driver is seated, press the power switch, the car will send out a starting sound (2-5seconds). Put the Forward/Backward switch into the position of "forward" (Press forward), step on the foot switch the car will move forward , loosen the pedal the car will stop. Put the Forward/Backward switch into the position of "Backward", step on the foot switch the car will move backward, loosen the pedal the car will stop.

4. Instruction for MP3 multifunction player

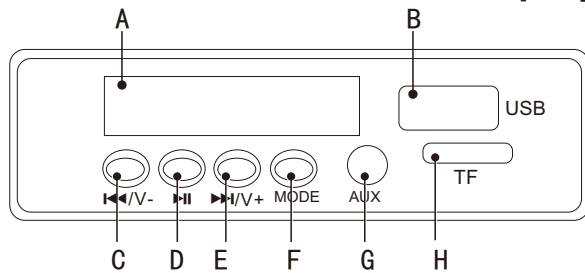

- A. Voltage display screen: The value on the display be used to determine whether the battery needs to be charged.
- B. USB connector: connect with other removable device to play audio file valid in MP3 mode.
- C. Last channel/volume down: short press to play the last channel, long press to lower the volume.
- D. Pause/play button
- E. Next channel/ volume up: short press to play the next channel, long press to increase the volume.
- F. Mode switch button: Music mode and radio mode
- G. AUX connector: connect with other removable device to play audio file valid in MP3 mode.
- H. TF card slot: Plug TF card into the TF card slot, the car will read and play the audio file in TF card. (Remark: Please build four folders in the card before using TF card , and folder name should keep in same as the one in MP3 multifunctional player, then it's workable to press the corresponding button to read and play the audio file)

5. The usage of the music switch and the horn button

Press the music switch to play different music. Press the horn button to play trumpet sound.

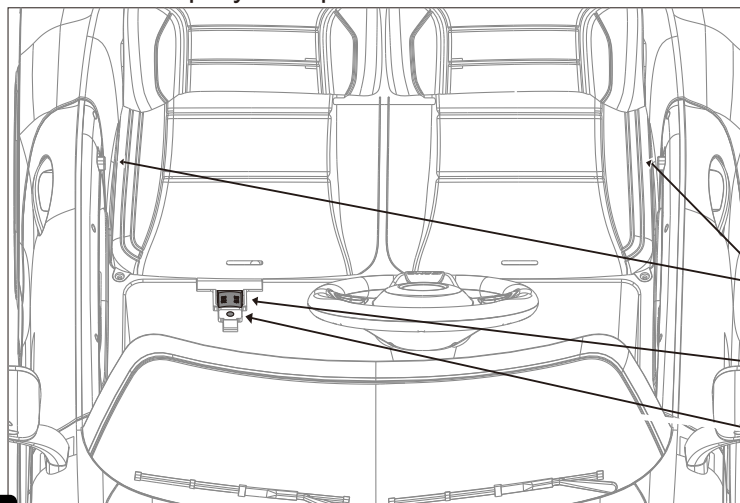

6. The illustration of High/Low Speed

The hi/lo speed switch into the position of “low speed”, step on the foot switch the car will move forward slowly, loosen the pedal the car will stop. Put the hi/lo speed switch into the position of “high speed”, step on the foot switch the car will move forward fast, loosen the pedal the car will stop.

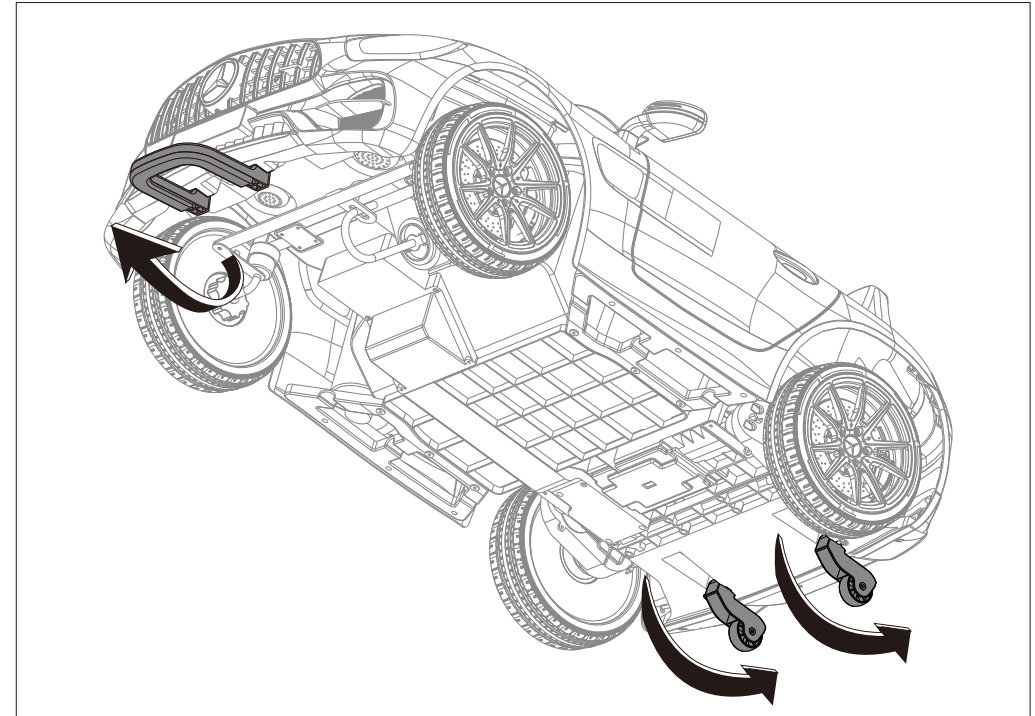

7. The illustration of High/Low Speed

Pull the folding tug under the rear car and the pull rod of the front car out in the direction indicated by the arrow. Pulling the pull rod can easily pull the car.

8. Instructions of the recoverable fuse

Resettable fuse: when the current exceeds a certain rating, the recoverable fuse will automatically cut off the power supply for 5-10seconds, then the current will be resupplied. (optional)

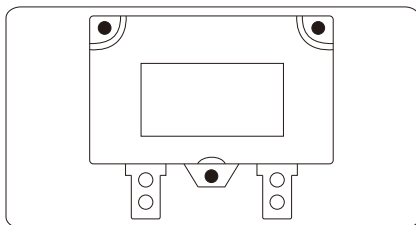

9. Charging instructions.

⚠ WARNING!

Please plug wall charger directly into a wall outlet. Do not use an extension cord.

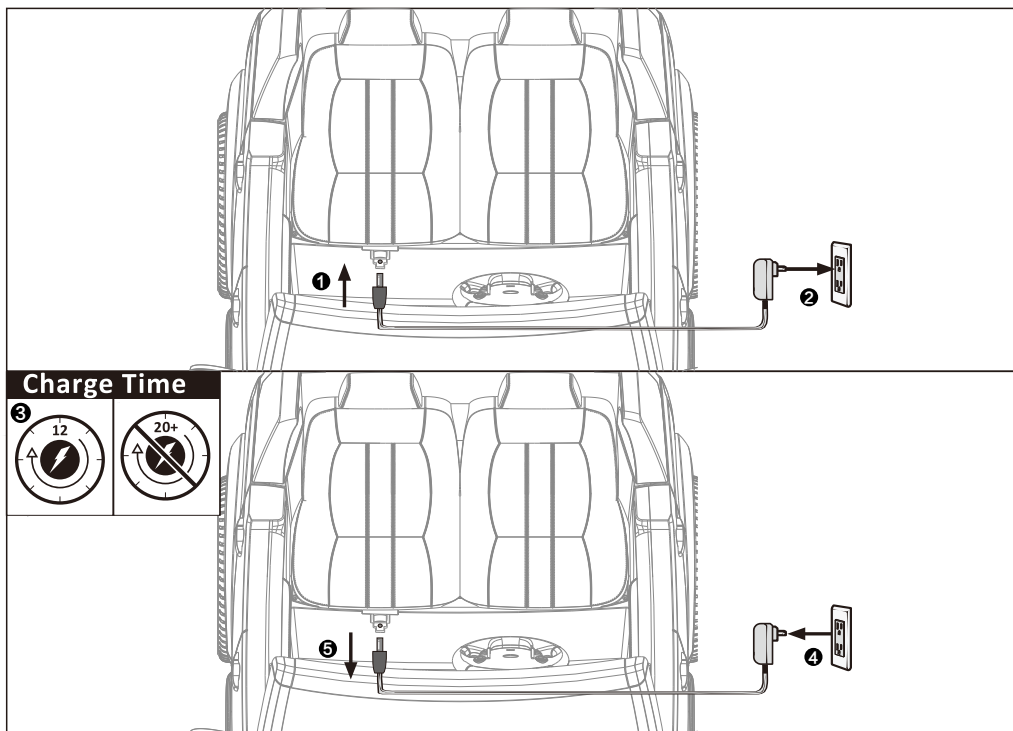

When battery power is low, please charge it immediately. The charging port is under the seat. (Note: toys can not be operated in the charging state. Toys should be charged under adult supervision).

Troubleshooting

Fault type	Reason analysis	Trouble elimination methods
The motor does not rotate	<ol style="list-style-type: none"> 1. Is the fuse overloaded? (under the seat) 2. The pedal switch connector is good? 3. The welding of motor electric terminal is good? 4. The connector of the motor wire is good? 5. Remove the motor's plug-in, change to connect battery directly, then check if it rotate or not. 	<ol style="list-style-type: none"> 1. Yes, the fuse cuts off the power automatically by 5-20 seconds, then restart; No, check next reason analysis 2. No, repair foot switch ; Yes, check next reason analysis 3. No, weld the terminal wire ; Yes, check next reason analysis 4. No, plug in the plug-in ; Yes, check next reason analysis 5. Still no rotation, change the motor; If rotates, it means driving circuit board needs professional maintenance, please contact with agent
Only move frontwards, or only move backwards	<ol style="list-style-type: none"> 1. Check the frontward/backward switch, check the connector is good or not by multimeter 2. Check the drive line cycle of frontward/bckwards is workable or not? 	<ol style="list-style-type: none"> 1. No, change the frontward /backward switch; 2. No, connect the line; Yes, it means driving circuit board needs professional maintenance, please contact with agent
slow speed	<ol style="list-style-type: none"> 1. Check the battery voltage is ok or not. 2. Connect the motor (including the driving gearbox) to the battery, then check the speed can be accelerated or not. 	<ol style="list-style-type: none"> 1. No, charger the battery ; Yes it's ok, check next reason analysis 2. No, check next reason analysis ; Yes, it means driving circuit board needs professional maintenance, please contact with agent
The battery can not be recharged	<ol style="list-style-type: none"> 1. The battery connector fall off or loosened. 2. The charger has a slight heat when it is charged 	<ol style="list-style-type: none"> 1. Yes, reconnect it, No, check next reason analysis 2. No, the charger is broken, replace it
When car is moving, the sound and light are useless	<ol style="list-style-type: none"> 1. check the sound/light switch is ok or not. 2. check the electric wire connection (from battery to headstock) is good or not? 	<ol style="list-style-type: none"> 1. No, replace the switch; Yes, check next reason analysis 2. No, reconnect; Yes, check next reason analysis
When wheel running, the car does not move	<ol style="list-style-type: none"> 1. check the driving wheel can be rotated or not? 2. Check the gearbox, if any gear is damaged? 	<ol style="list-style-type: none"> 1. Yes, lay the wheel to the ground; No, checks the next reason analysis 2. Yes, replace the gear box; No, checks the next reason analysis
Car is unstable, moving on and off	<ol style="list-style-type: none"> 1. Does the driver exceed the maximum load 40kg? 2. Does the driver ride on the rugged road? 3. Check the wheel can rotate freely? 	<ol style="list-style-type: none"> 1. Yes, should follow the instruction, the car unsuitable for exceed maxweight; No, check the next reason analysis 2. Yes, should follow the instruction, ride on the flat cement road ; No, check the next reason analysis No, Troubleshooting wheel and axle

