

REPAIR SHEET

BRAND RYOBI		DESCRIPTION 18 Volt Brushless Power Head
MODEL NO. P20104 P20104VNM	MFG. NO. 315286001 315286101	

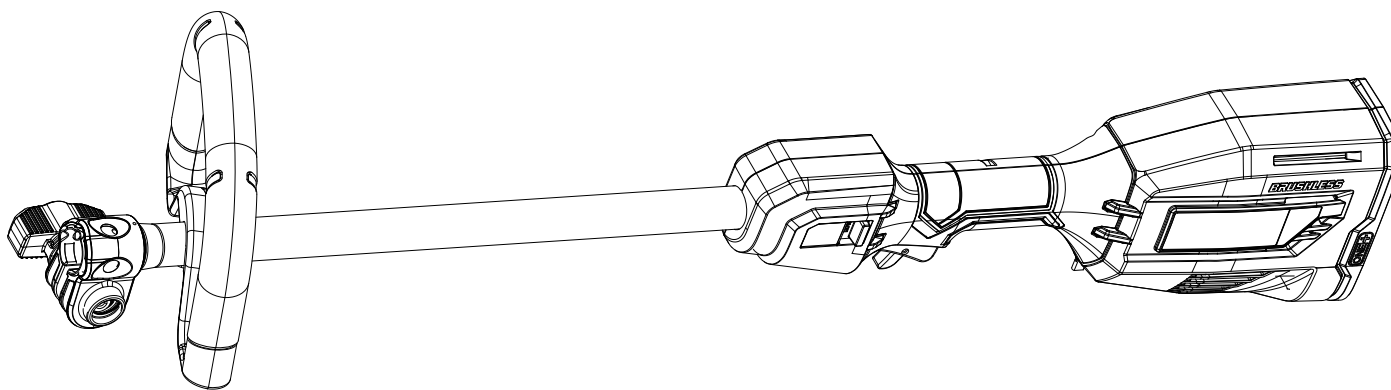

TECHTRONIC INDUSTRIES POWER EQUIPMENT

P.O. Box 1288, Anderson, SC 29622 ■ 1-800-525-2579 ■ www.ryobitools.com

1-11-21 (Rev:04)

The model number and manufacturing location will be found on a label attached to the product. Always mention this information in all communications regarding this product and when ordering parts.

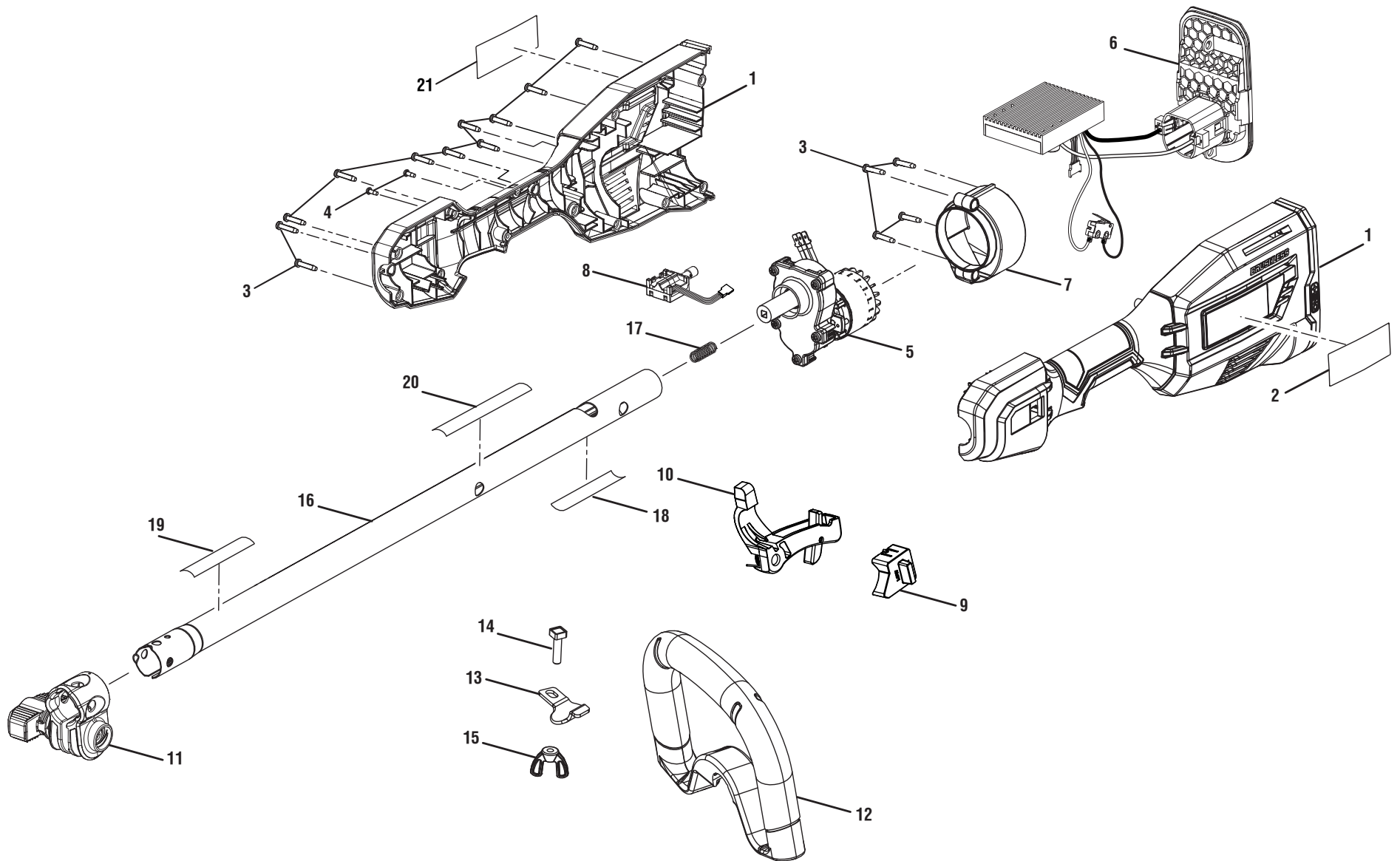



P20104/P20104VNM

PARTS LIST

KEY NO.	PART NO.	DESCRIPTION	QTY.
1	315989001	Rear Handle Assembly (Inc. Key No. 2 & 21)	1
2	940705585	Logo Label	1
3	661864007	Screw (M4 x 18 mm, T15 Torx Pan Hd.)	15
4	660203052	Screw (M3 x 8 mm, Pan Hd.)	2
5	313244003	Motor & Gear Box Assembly	1
6	292194001	Motor Controller & Switch Assembly	1
7	315990001	Motor Volute Assembly	1
8	760649001	Variable Speed Switch	1
9	539255001	Hi-Lo Switch Cover	1
10	314833001	Switch Trigger Assembly	1
11	315386001	Boom Clamp Assembly	1
12	308056009	Front Handle Assembly (Inc. Key Nos. 13-15)	1
13	639167001	Assist Handle Clamp	1

KEY NO.	PART NO.	DESCRIPTION	QTY.
14	660857001	Screw (1/4-20 x 40 mm, Hex Hd.)	1
15	518949001	Wing Nut (1/4-20)	1
16	315991001	Boom Assembly (Inc. Key Nos. 19-22, P20104)	1
	316009001	Boom Assembly (Inc. Key Nos. 19-22, P20104VNM)	1
17	690140011	Compression Spring	1
18	941013005	Warning Label (French/Spanish)	1
19	941851150	Attachment Capable Label	1
20	941588795	Warning Icons Label	1
21	941588484	Data Label (P20104)	1
	941588902	Data Label (P20104VNM)	1
	Not Shown:		
	995000973	Operator's Manual	



P20104/P20104VNM

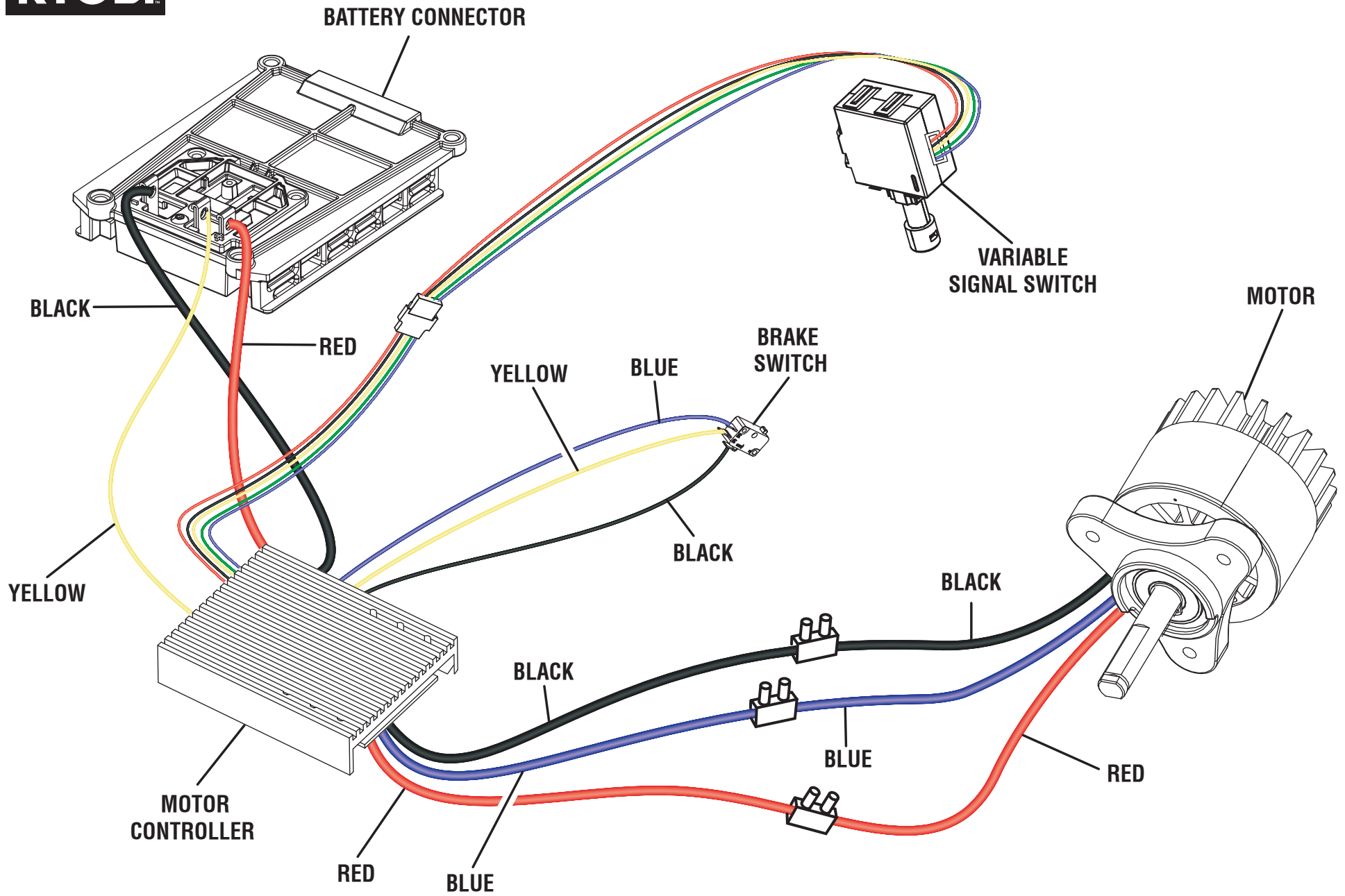

WIRING DIAGRAM

REPAIR SHEET

BRAND RYOBI		DESCRIPTION EXPAND-IT Straight Shaft Trimmer Attachment
MODEL NO. RY15527 RY15527VNM	MFG. NO. 311247006 311247106	

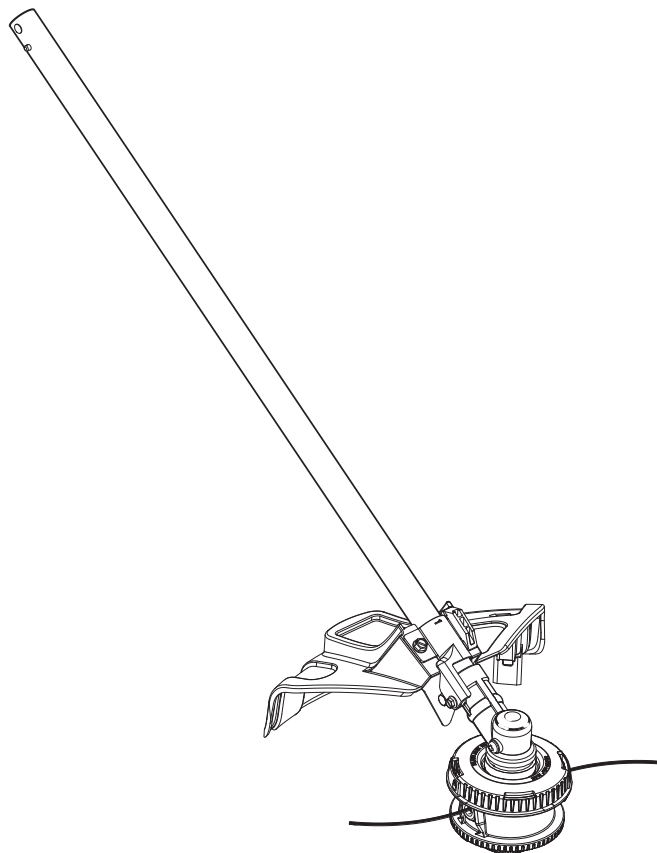

TECHTRONIC INDUSTRIES POWER EQUIPMENT

P.O. Box 1288, Anderson, SC 29622 ■ 1-800-525-2579 ■ www.ryobitools.com

1-11-21 (Rev:06)

The model number and manufacturing location will be found on a label attached to the product. Always mention this information in all communications regarding this product and when ordering parts.

PARTS LIST

KEY NO.	PART NO.	DESCRIPTION	QTY.
1	941588552	Max. Run Time/Performance Label	1
2	315992001	Straight Shaft Assembly (Inc. Key Nos. 3-5, RY15527)	1
	316008001	Straight Shaft Assembly (Inc. Key Nos. 3-5, RY15527VNM)	1
3	940749034	Lower Boom Icon Label	1
4	941851149	Ryobi Expand-it Label	1
5	941588488	Data Label (RY15527)	1
	941588903	Data Label (RY15527VNM)	1
6	660738002	Screw (1/4-20 x 1-1/4 in., Hex Washer Hd.)	1
7	679958001	Compression Spring	1
8	313285005	Grass Deflector Assembly (Inc. Key Nos. 1, 6-7, & 9-10)	1
9	638016003	Line Cut-off Blade	1
10	662148001	Screw (M4.5 mm x 1 mm, Pan Hd.)	2
11	660642001	Screw (1/4-20 x 1-1/4 in., Hex Washer Hd.)	1
12	660641001	Screw (10-24 x 5/8 in., Hex Washer Hd.)	1
13	678011001	Flanged Washer	1
14	308210009	Gear Head	1
15	518367001	Spacer	1
16	638125001	Grass Deflector Clamp	1
17	532048003	Crank Handle	1
18	314608005	Bump Feed Trimmer Head Assembly (Inc. Key No. 19)	1
	Not Shown:		
	995000976	Operator's Manual	

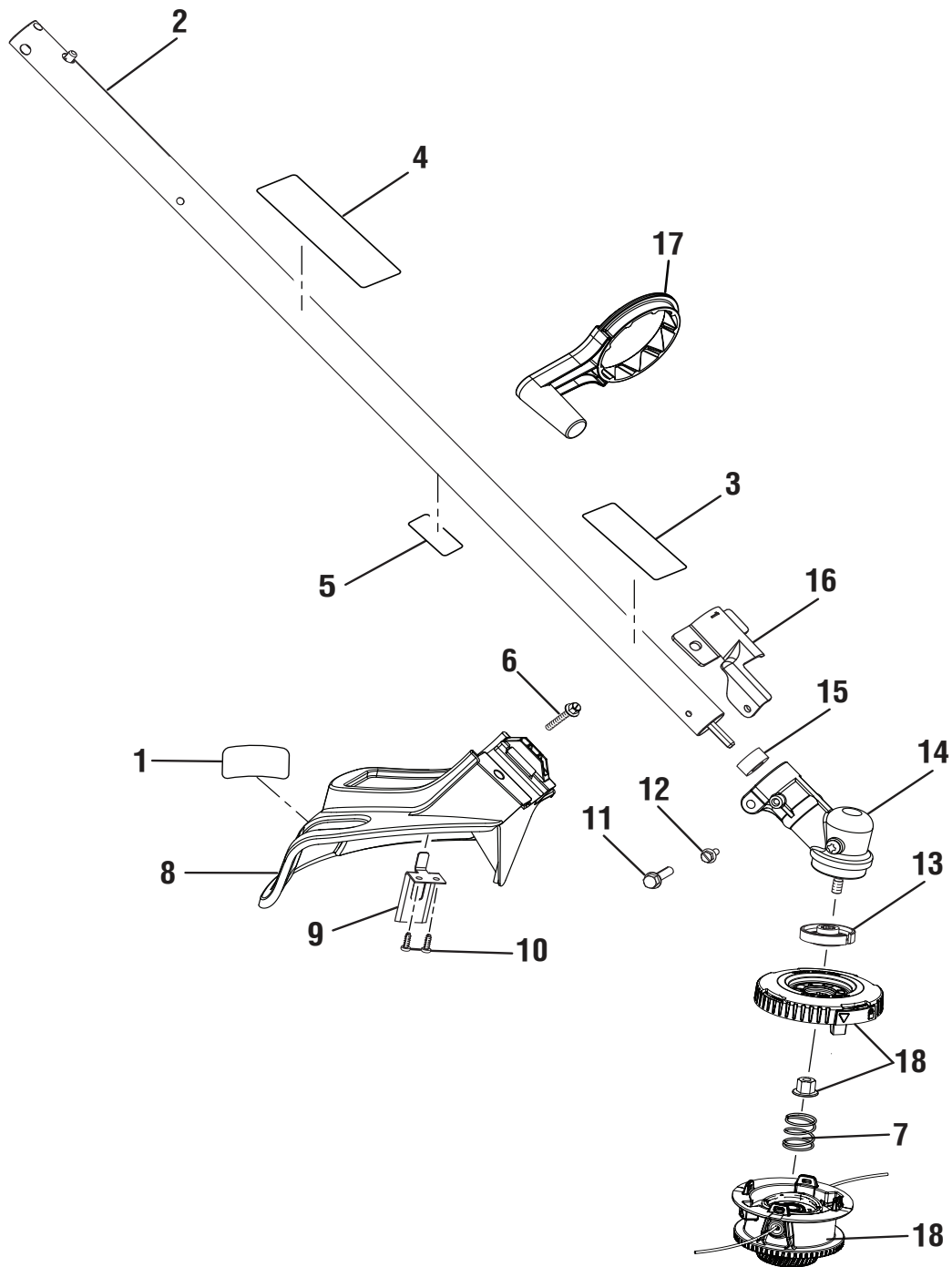

RYOBI
18 Volt Blower
Item No. P21010VNM
Mfg. No. 108606001
Repair Sheet

TECHTRONIC INDUSTRIES POWER EQUIPMENT

P.O. Box 1288, Anderson, SC 29622 USA

1-800-860-4050 www.ryobitools.com

RYOBI BLOWER – ITEM NO. P21010VNM

PARTS LIST

KEY NO.	PART NUMBER	DESCRIPTION	QTY
1	205320001	Blower Tube Assembly (Inc. Key No. 2)	1
2	941588617	Quiet Blower Label.....	2
3	940657339	Warning and Warning Icons Label (English).....	1
4	539700001	Stator	1
5	565534001	Rubber Block	4
6	742667001	Motor.....	1
7	539699001	Motor Mount	1
8	T662472001	Screw (M3 x 8 mm, Pan Hd.)	4
9	612854002	Bushing	1
10	539703001	Fan	1
11	678774009	Lock Nut (M6).....	1
12	539698001	Inlet Bell	1
13	316023001	Inlet Cover Assembly	1
14	940657338	Warning Icons Label	1
15	661817001	Screw (M4 x 14 mm, T15 Torx Pan Hd.)	16
16	205319001	Housing Assembly (inc. Key Nos. 3, 14, 17 and 23-24).....	1
17	941851093	Logo Label	2
18	205321001	Motor Controller and Battery Connection Assembly	1
19	760952002	Variable Speed Switch	1
20	539319001	Switch Cap.....	1
21	539314001	Turbo Button	1
22	539318001	Trigger	1
23	941588616	Data Label	1
24	940851559	Warning Label (French and Spanish)	1
	Not Shown		
	998000055	Operator's Manual	
	12-19-19		
	(Rev:01)		

RYOBI BLOWER – ITEM NO. P21010VNM

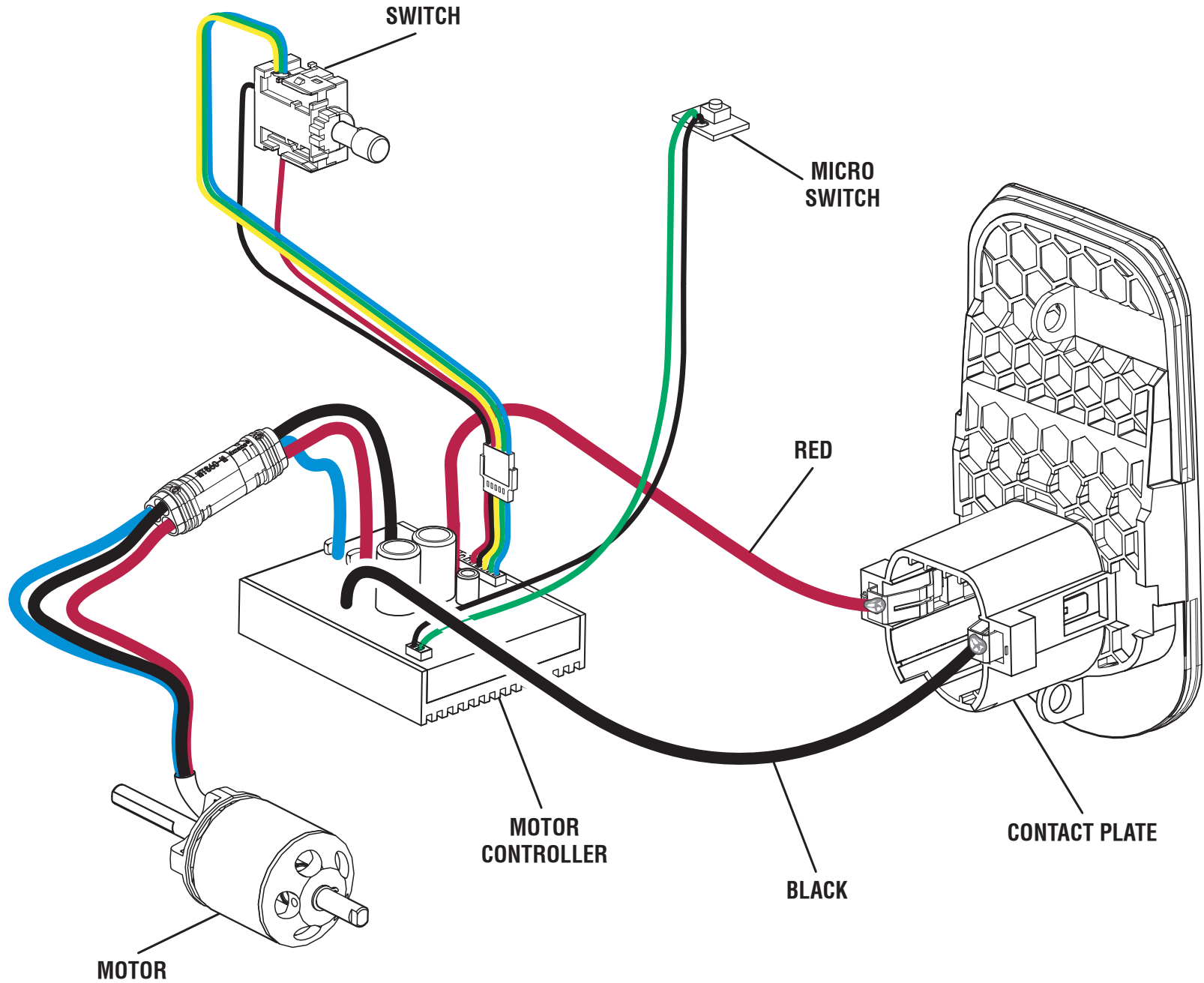

WIRING DIAGRAM