

717420218

Owner's Manual & Assembly Guide



www.arrowsheds.com

Model No. AR108 LW108

LW108LM

10' x 8'

Nominal Size

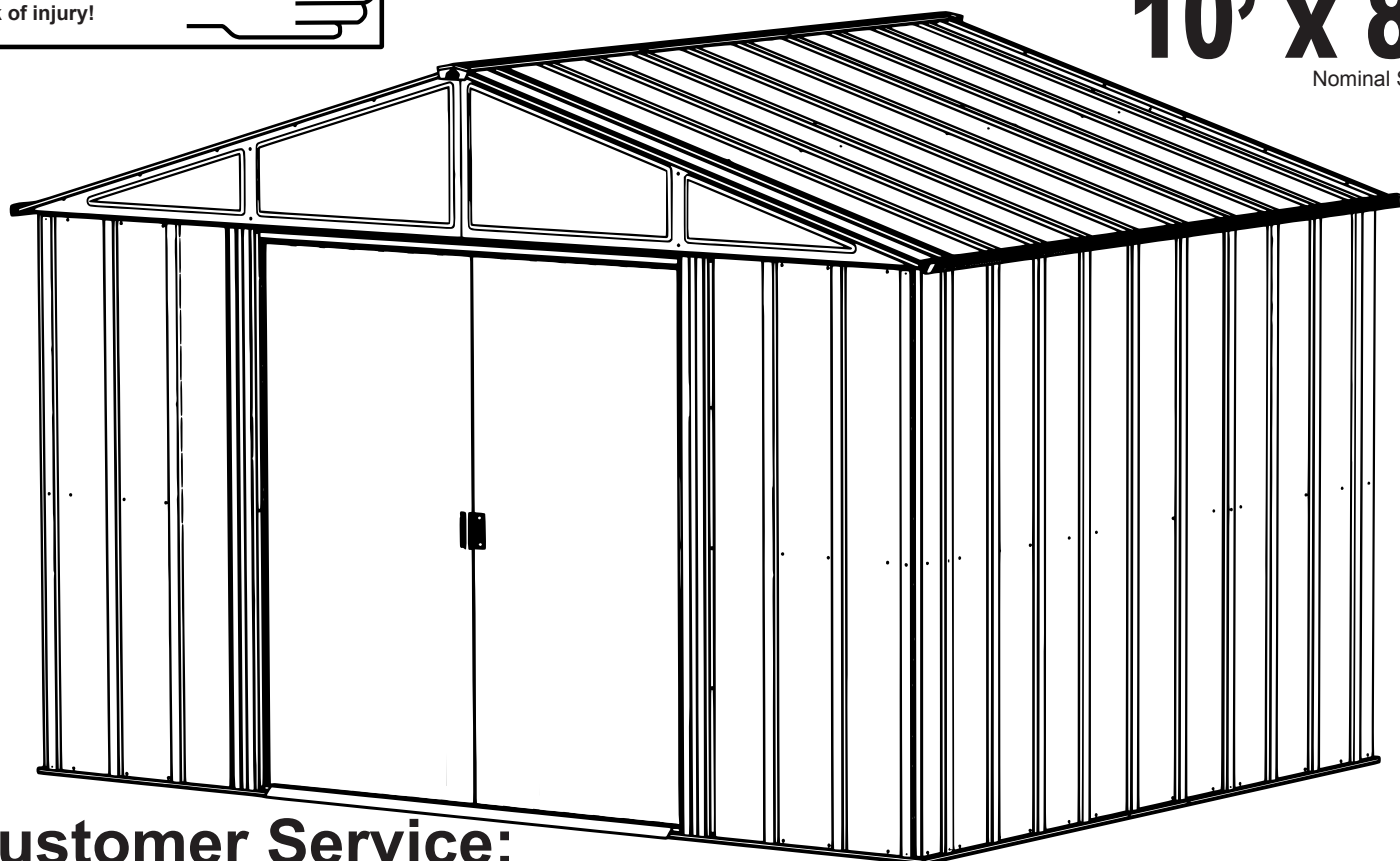

Customer Service:
1-800-851-1085 or
assist@arrowsheds.com

Base Size	121" x 92 3/4" 307,3 cm x 235,6 cm
------------------	---------------------------------------

For proper base construction see page 12

BUILDING DIMENSIONS

† Size rounded off to the nearest foot

Approx. † Size	Storage Area	440 Cu. Ft.	Exterior Dimensions (Roof Edge to Roof Edge)			Interior Dimensions (Wall to Wall)			Door Opening	
			Width	Depth	Height	Width	Depth	Height	Width	Height
10' x 8'	74 Sq. Ft.		123 1/4"	95 1/4"	81 3/8"	118 1/4"	90"	80 1/8"	55 1/2"	60"
3,0 m x 2,3 m	6,9 m ²	12,5 m ³	313,1 cm	241,9 cm	206,7 cm	300,4 cm	228,6 cm	203,5 cm	141,0 cm	152,4 cm

* See Inside for Detailed Safety Information.

SAFETY PRECAUTIONS...

Safety precautions MUST be followed at all times throughout the construction of your building!

sharp edges

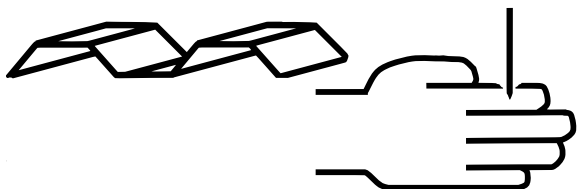

Care must be taken when handling various pieces of your building since many contain sharp edges. Please wear work gloves, eye protection and long sleeves when assembling or performing any maintenance on your building.

always practice proper tool safety

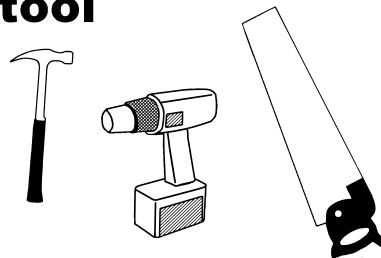

Practice caution with the tools being used in the assembly of this building. Be especially familiar with the operation of all power tools.

no children or pets at worksite



Keep children and pets away from the worksite during construction and until the building is completely assembled. This will help avoid distractions and any accidents which may occur.

don't focus weight on roof

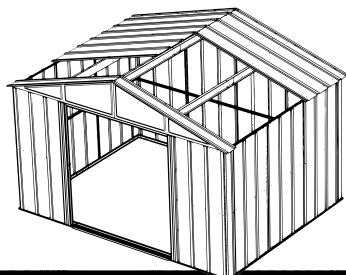

NEVER concentrate your weight on the roof of the building. When using a step ladder make sure that it is fully open and on even ground before climbing on it.

beware of wind



Do NOT attempt to assemble your building on a windy day. The large panels can catch the wind like a "sail", causing them to be whipped around making construction difficult and unsafe.

Do NOT attempt to assemble your building before double checking that you have all the parts indicated in the parts lists (page 8) as well as all hardware (page 7). Any building left partially assembled may be seriously damaged by even light winds.

IMPORTANT NOTE ON ANCHORING

- Your building MUST be anchored to prevent wind damage. An anchoring kit is not supplied with your building and you have many options when it comes to anchoring. See anchoring page for more info.
- You must also have a temporary anchoring system in place in case you need to take a break from assembly. See page 4 for more info.

ASSEMBLY TIPS & TOOLS

Watch the Weather Closely: Be sure the day you choose to install your building is dry and calm. Do **NOT** attempt to assemble your building on a windy day. Be careful on wet or muddy ground.

Use Teamwork: Two or more people are required to assemble your building. One person can hold the parts or panels in place while the other person fastens them together and handles the tools. This makes the process of assembling your building faster and safer.

Tools and Materials: Here is a list of some basic tools and materials you will need to assemble your building. Decide which method of anchoring and the type of base you will use to make a complete list of the materials you will need.

WHAT YOU NEED

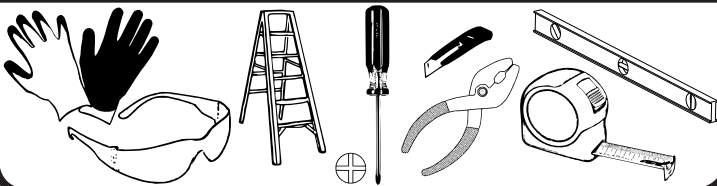

- Work Gloves
- Safety Glasses
- Step Ladder
- No. 2 Phillips Screwdriver (Magnetic Tip Preferred)
- Utility Knife or Scissors
- Pliers
- Carpenter's Level
- Tape Measure

RECOMMENDED TIME SAVERS

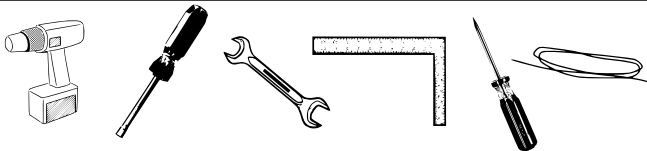

- Power Drill (Cordless, Variable Speed)
- Nut Driver or Wrench
- Square
- String (for squaring the frame)
- Awl (to align holes)

BASE PREPARATION TOOLS

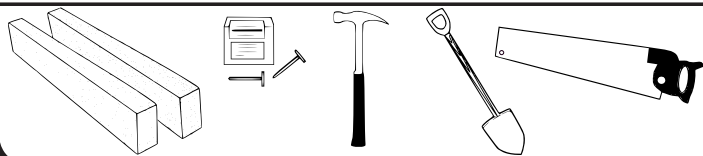

- Lumber and/or Concrete
- Hammer and Nails
- Spade or Shovel
- Hand Saw or Power Saw

How to Select and Prepare Your Building Site: Before you start to assemble your building, you will want to decide on a good location. The best location is a level area with good drainage.

- Allow enough working space so it is not difficult to move parts into position for assembly. Be sure there will be enough space at the entrance for the doors to completely open. Also, there needs to be enough space outside the building to be able to fasten the panel screws from the outside.
- Before assembling any parts, your base should be constructed and an anchoring system should be ready to use.

FREQUENTLY ASKED QUESTIONS

Q. How long will it take to assemble the building?

A. Assembly time depends on a variety of factors, including roof design, tools available, DIY skill and the pace at which you work. Guidelines for each shed assembly are approximate AFTER completion of the base, and assume two or more people working on the assembly. Generally, you should plan on at least one day working with someone who can assist you; again, after constructing the base. Refer to the clock icons on each product page on the website for specific time estimates.

Q. How do I decide where to put my shed?

A. The key to a successful assembly is to make sure the shed will be square and level when built. The shed can be assembled directly onto level ground (grass or dirt). If you have location options, choose one that is already flat, with good drainage to control moisture. If you don't have a flat, well-drained area, you need to prepare the space. Level the area using cinder blocks, concrete, crushed gravel or other sturdy materials. Once level with good drainage, construct your base. Using a carpenter's level, make sure your base is level and free of bumps or ridges to provide good support for your building.

Q. What if I can't finish my building in one session?

A. If weather conditions change so that it becomes windy or rainy, it is recommended that you stop assembly until conditions improve. This is for your safety and for protection of the shed panels. However, do not leave your unfinished construction without first temporarily anchoring the corners of the shed to your base and placing weights, such as patio blocks or sandbags, on the floor frame. Failure to anchor the building if you leave it while partially assembled could result in irreparable damage or personal injury if the building collapses.

Note: Most instruction manuals provide a warning note at the beginning of the installation step for corner panels, stating that the remainder of the building assembly requires multiple hours and more than one person. Do not continue beyond this point if you do not have enough time or help to complete the assembly that day. A partially assembled building can be severely damaged by even light winds.

Q. Do I need to anchor my building?

A. Yes! Fully assembled buildings should be anchored using a permanent anchoring system. If you need to leave your building before it is completely assembled, you will need to temporarily anchor the corners of the shed to your base, and place weights, such as patio blocks or sandbags, on top of the floor frame.

Note: If you have to stop assembly for any reason before it is complete, do not leave your unfinished construction without first temporarily anchoring the corners of the shed to your base and placing weights, such as patio blocks or sandbags, on the floor frame.

Q. How do I temporarily anchor my building before it's fully assembled?

A. An incomplete building must be anchored before breaking for any period of time to prevent possible damage.

- If the building is on a wood base, secure the frame with wood screws in the corners
- If the building is on a concrete base, temporarily anchor the frame in the corners
- Use patio blocks or sandbags on top of the floor frame as weights
- Secure the floor frame to the ground with ground augers or rope the frame in the corners to the ground

Q. What kind of base do I use?

A. You can:

- Use an Arrow Base Kit
- Pour a concrete slab
- Build a wood deck/floor (use exterior-grade plywood)
- Use patio blocks
- Build on crushed gravel, dirt or grass

Arrow provides a base kit accessory that is an option for most building sizes. If you are building a wood deck/floor, an Arrow floor frame kit on top of your deck/floor assembles in minutes and provides a floor frame suitable for a 5/8" exterior-grade plywood floor (not included). A continuous unbroken plastic vapor barrier with a thickness of 6 mil. between the ground and the building's base is also recommended.

Q. How should I measure for my base?

A. Shed dimensions are provided in "nominal" size. Nominal sizes are roof-edge measurements rounded to the nearest foot and are not the measurements to use for constructing the shed base. So, carefully check the exact, recommended base size in the specifications for your shed model.

Q. How do I align the holes in the wall panels with the holes in the floor frame?

A. Make sure that the shed is level and square, with the correct floor frame size, and that the corner panels are installed correctly. Line up the large hole in the panel with the small holes in the floor frame. An awl can be used to help align the holes.

Q. How do I align the holes in the roof panels with the holes in the roof beam and side wall angles?

A. Your building must be level and square in order for the holes to align. It must be square at both the top and bottom. Check that the building is square by measuring diagonally. The two diagonal measurements will be equal. If your building is out of square, carefully rock and push the shed until it is square. Also, try loosening the roof beams to give more play and flexibility. Non-alignment can also occur if your building is not level. You can raise corners and shim under them to make it level. Check that the panels are installed in the proper location. The building should not be permanently anchored until the complete unit is assembled; otherwise, you will not be able to make adjustments for squareness during assembly. Do not attach the bottom of the roof panels to the side wall angles until all the roof panels are up.

Note: If you have to stop assembly for any reason before it is complete, do not leave your unfinished construction without first temporarily anchoring the corners of the shed to your base and placing weights, such as patio blocks or sandbags, on the floor frame.

Q. How do I ensure that the sliding doors on the building will hang level?

A. Make sure that the door track has been correctly installed, with the long leg on top and the short leg on the bottom. Check that the door slides are straddling the upper and lower legs of the door track assembly, putting the door slide only halfway in the track. Also, the rounded end of the door slide should be at the bottom and the square end at the top.

Q. What kind of customer support is available?

A. Our instruction manuals contain step-by-step assembly illustrations and guide you from preparation through assembly to care and maintenance of your finished building. Each part is marked with a factory number for easy identification. In addition, our assembly animation (located under the Customer Support menu on the website) provides helpful tips. But if you need to reach someone at Arrow, you can contact Arrow Customer Service, toll free, at 1-800-851-1085 (press 1) or via e-mail at assist@arrowsheds.com. Have your model number and instruction manual with you when you call.

Q. What if the rear wall angle and channels are too large to fit inside of the rear wall panels?

A. Check the dimensions of wall assemblies. They should be slightly smaller than the floor frames. Lay the assemblies on top of the rear floor frame and pull them up to the top of the wall panels causing the corner panels to stand erect and not lean inward. Caution: Be careful to not scratch the panels on the way up.

Q. The wide rib always overlaps the crimped rib. Is there ever an exception?

A. This sequence is to be followed through the assembly process. However, this will typically happen once on the rear and once on each side wall (vertical wall units only) where there will be either two crimped ribs overlapping or two wide ribs overlapping. This may give it a tighter fit, but it will work.

Q. Can the building be painted?

A. The buildings can be painted with an exterior-grade paint designed for use on steel. Contact your local paint supplier for recommendations.

Q. I heard that rust might be an issue with steel; is it?

A. While steel can rust, with proper care this should not be an issue. For a long-lasting finish, periodically clean the exterior surface and apply spray-on car wax. Touch up scratches as soon as you notice them by immediately cleaning the area with a wire brush or emery paper, washing it and applying touch-up paint. This will minimize rust and maintain your shed's attractive appearance for years.

Q. How do I take care of dents in my shed?

A. Proper selection of shed size, including a sufficient door-opening width, and proper placement of your shed should minimize the possibility of damage. If a dent does occur, carefully push the dent out from the opposite side. If the paint has been scratched or removed, touch up the area as soon as you notice it. Immediately clean the area with a wire brush or emery paper, wash it and apply touch-up paint. This will minimize rust and maintain your shed's attractive appearance for years.

Still have questions? Visit us online at www.arrowsheds.com to view lots of helpful tips and information regarding all of our available products. You can also contact our Customer Service team at 1-800-851-1085 (press 1), or via e-mail at assist@arrowsheds.com.

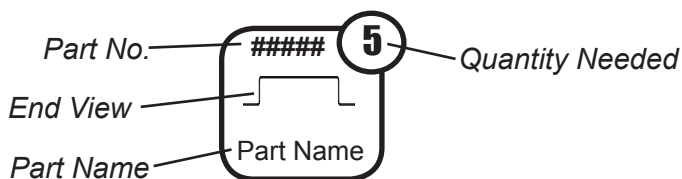

At the top of each page you will see one or more **Part Cues** like the one to the left. These **Part Cues** are designed to help you quickly identify the parts needed for each step.

Confirm that all hardware and parts are present before attempting to assemble your building.

For missing or damaged parts contact Customer Service. Do not return to store.

Customer Service:

1-800-851-1085 or
assist@arrowsheds.com

Part Numbers

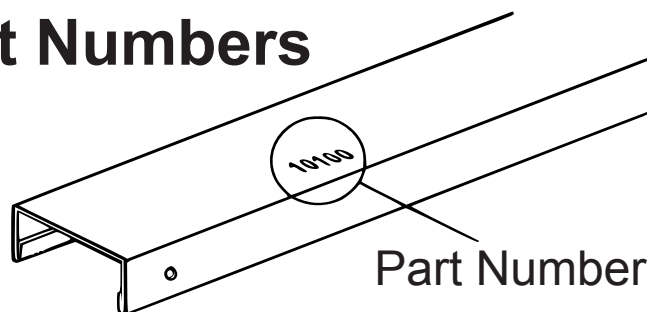

1. Each part has an identifying part number on it.
2. Part Numbers are referenced in each step.
3. Unpainted parts have a stamped in number and painted parts have a number that is inked on.

Remove inked on numbers with soap and water after assembly.

HARDWARE LIST...

Hardware Views by Key No.

Key No.	Part No.	Part Description	Qty.	✓ List
1	65103	Hex Nut (#8-32)	169	
2	65900A	Black Screw (#10B x 1/2) (13 mm)	8	
3	65923	Bolt (#8-32 x 3/8) (10 mm)	169	
4	65004	Screw (#8AB x 5/16) (8 mm)	338	
5	66045	Door Handle	2	
6	66646	Washer Sheet	10	
7	65109	Acorn Nut	4	
8	67468	Peak Cap	2	
9	66769	Door Slide	4	
10	66382	Lower Door Guide	4	
11	66183L	Left Roof Trim Cap	2	
12	66183R	Right Roof Trim Cap	2	
13	67545	Weather Stripping	1	
14	6228	Track Support	2	

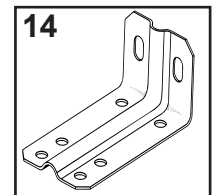
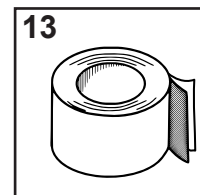
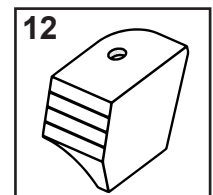
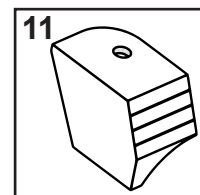
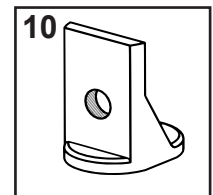
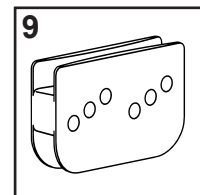
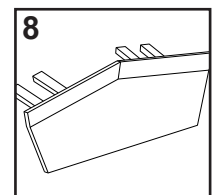
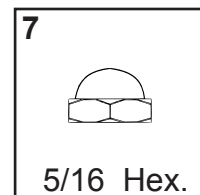
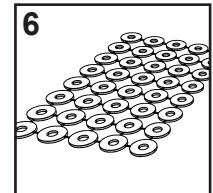
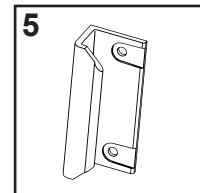
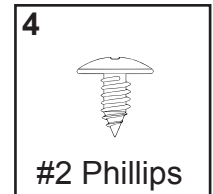
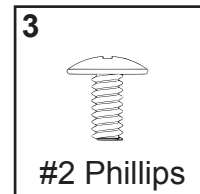
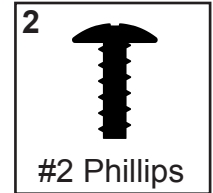
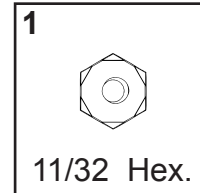

The fasteners used in each step are shown actual size at the top of each page. If you are unsure which fastener to use, hold it up to the picture and use the one that matches.

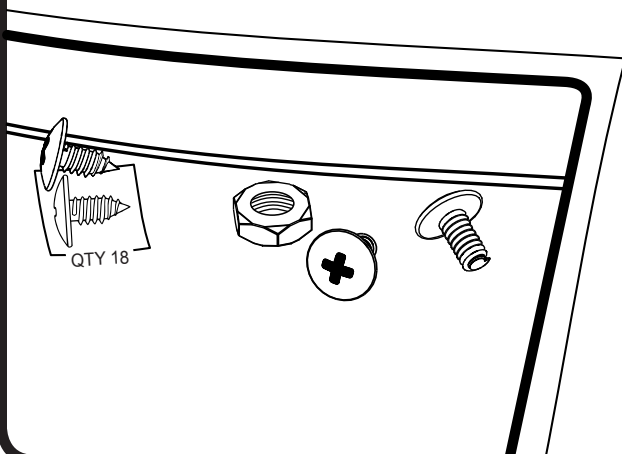

PARTS LIST...

Selected End Views by Key No.

Key No.	Part No.	Part Description	Qty.	✓ List
1	3719	Door Handle Brace	2	
2	7332	Wall Panel (Side)	4	
3	9373	Front Wall Panel	2	
4	9365	Front Wall Channel	2	
5	5986	Rear Wall Angle	2	
6	8576	Right Gable	2	
7	8577	Left Gable	2	
8	10497	Horizontal Door Brace	4	
9	6278	Vertical Door Brace	2	
10	6403	Door Track Splice	1	
11	9366	Door Track	2	
12	6515	Wall Panel	6	
13	7743	Roof Panel	2	
14	9009	Gable Brace	2	
15	10475	Door	2	
16	7571	Roof Panel	4	
17	9369	Door Jamb	2	
18	9917	Rear Wall Channel	2	
19	8578	Right Roof Panel	2	
20	8579	Left Roof Panel	2	
21	8485	Left Side Roof Trim	2	
22	8840	Ridge Cap	1	
23	10470	Roof Beam	8	
24	8836	Right Side Roof Trim	2	
25	9922	Side Wall Channel	4	
26	8841	Side Wall Angle	4	
27	8486	Ridge Cap	1	
28	8934	Ramp	1	
29	9367	Front Floor Frame	2	
30	8936	Rear Floor Frame	2	
31	8937	Side Floor Frame	4	
32	8470	Corner Panel	4	
33	6635	Roof Beam Bracket	4	
34	9204	Roof Beam Brace	2	
35	69835	Edge Trim (Green)	4	

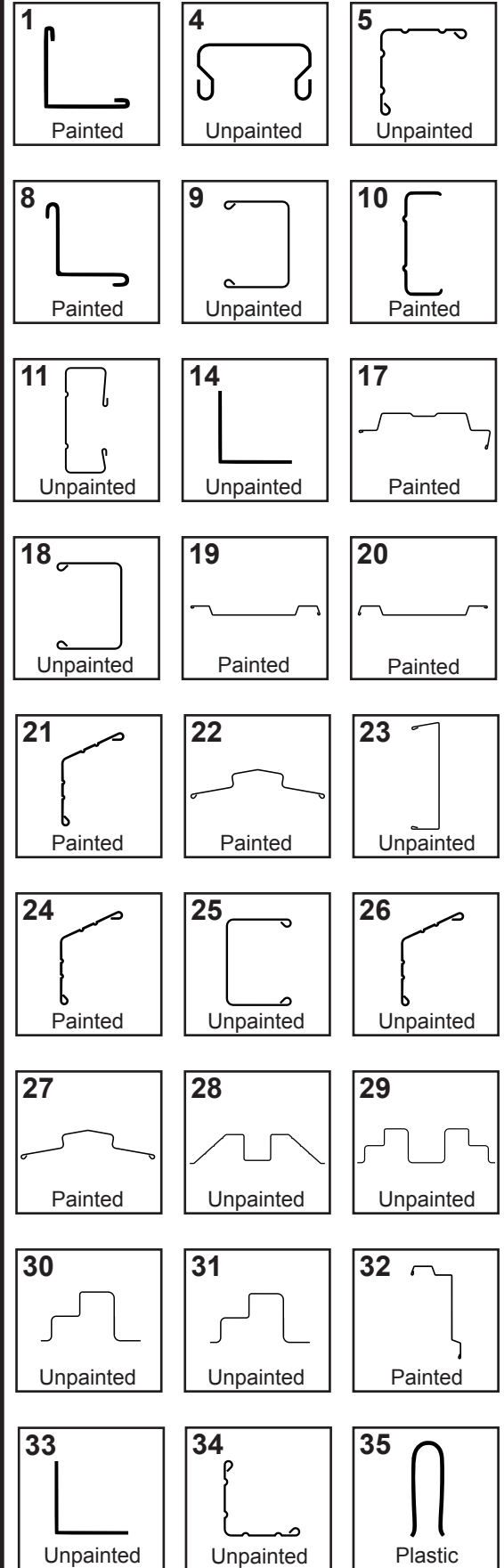

ASSEMBLY BY KEY NO.

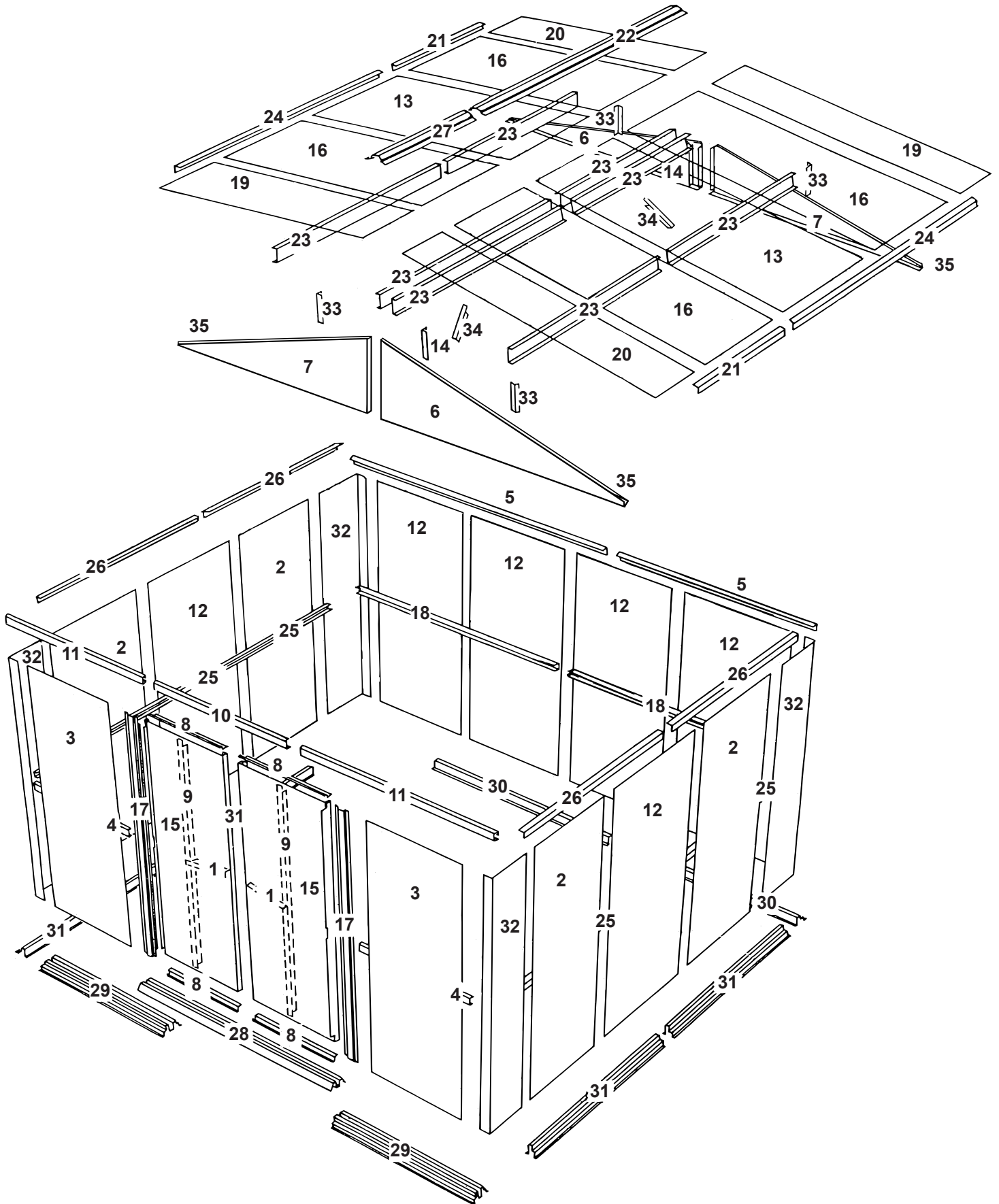

ASSEMBLY OVERVIEW

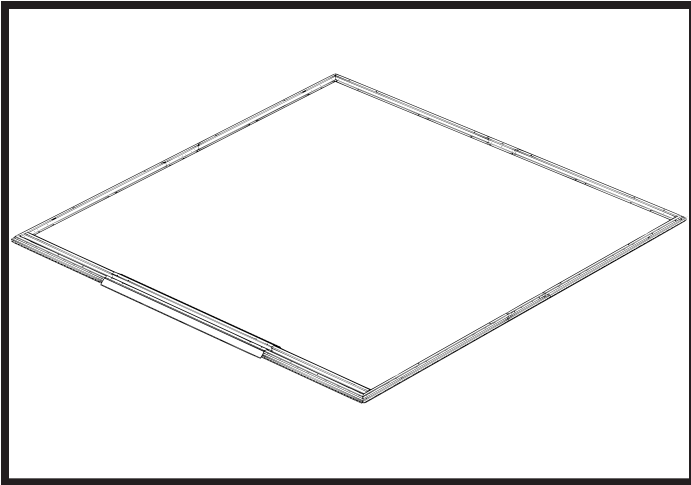

Build the Floor Frame

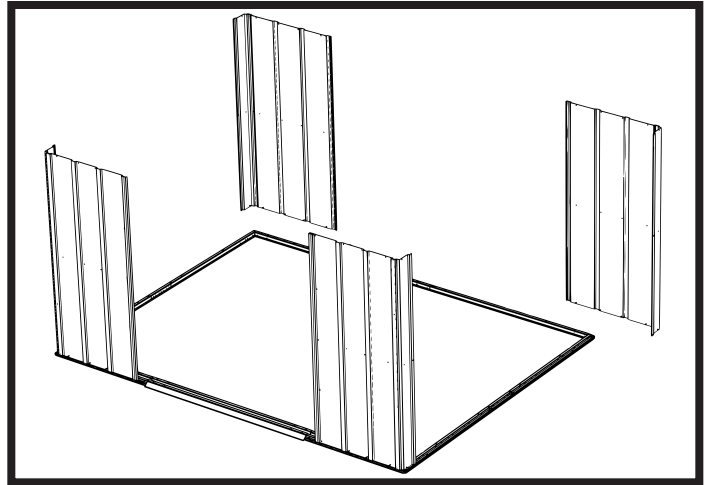

Erect the Corners

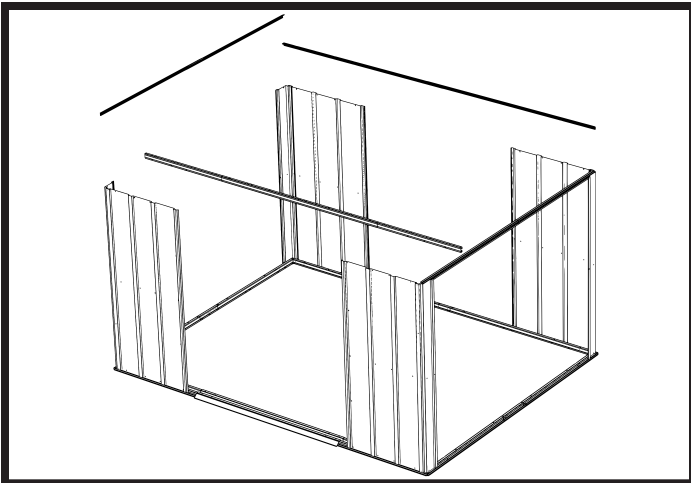

Install Upper Wall Frames

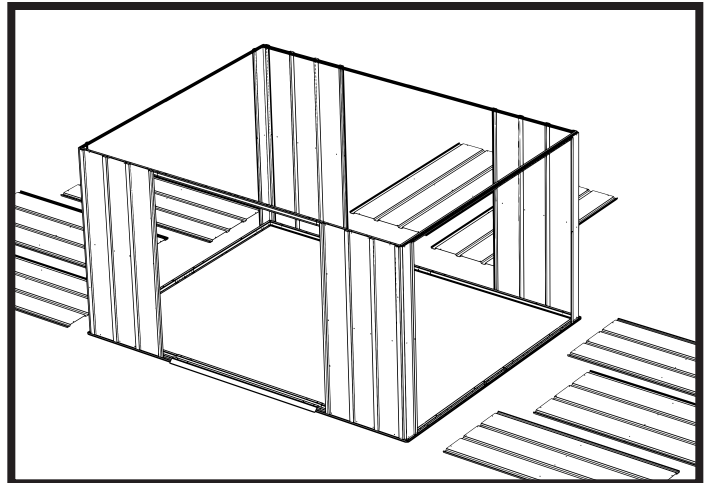

Lay Out Wall Panels

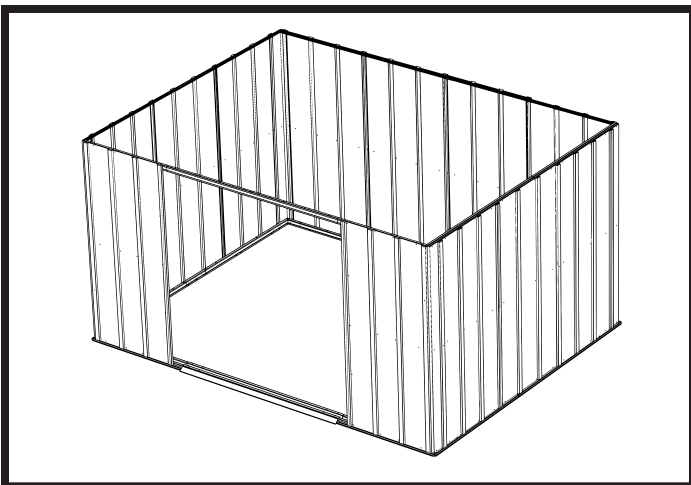

Install Wall Panels

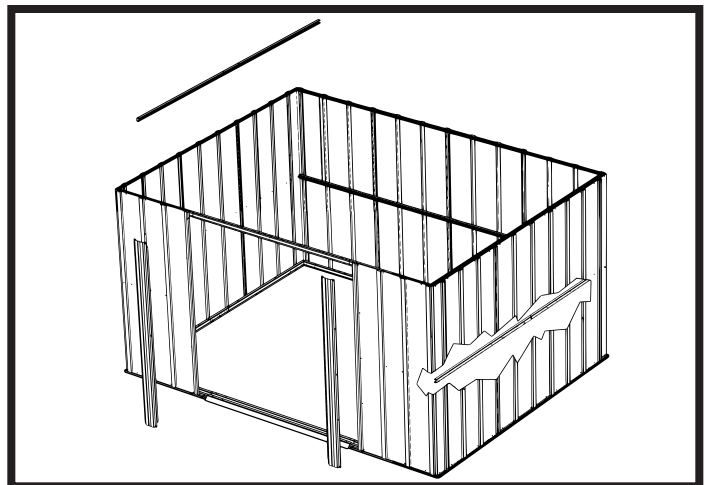

Install Door Jambs & Channels

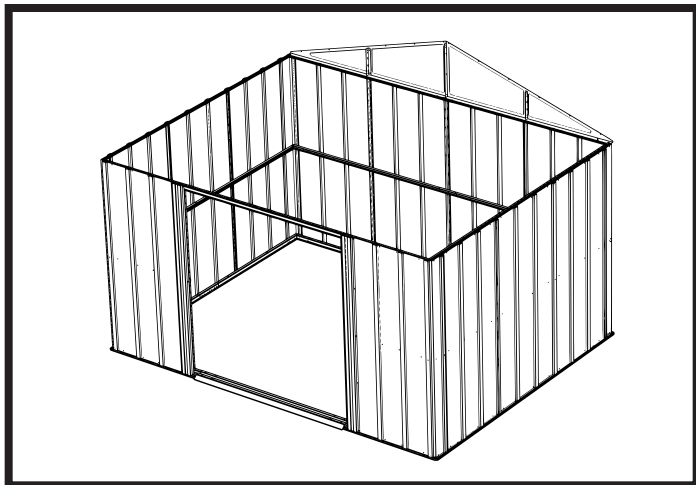

Install Gables

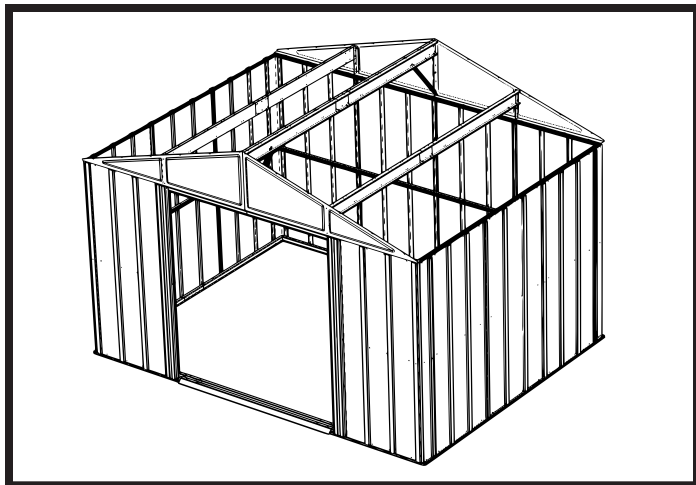

Install Roof Beams

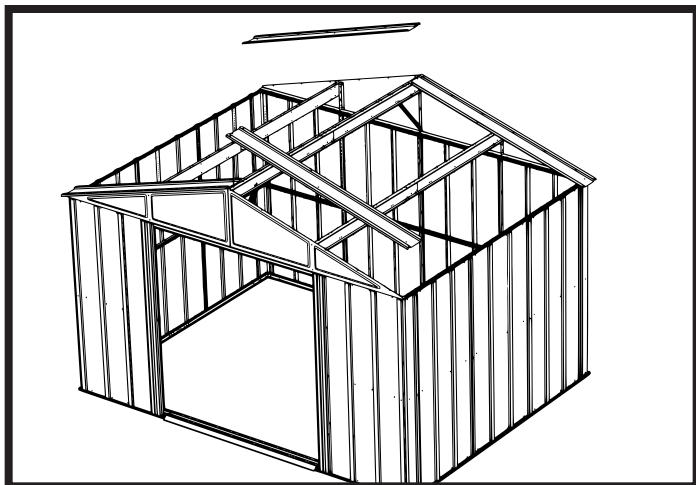

Install Roof End Panels

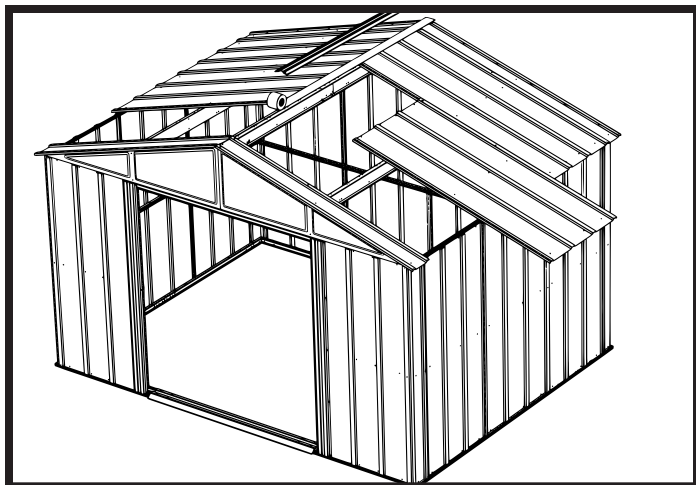

Install Roof Panels

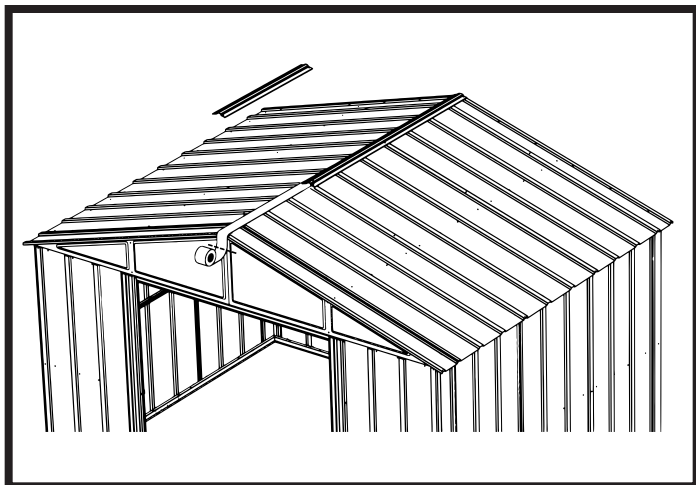

Install Ridge Caps

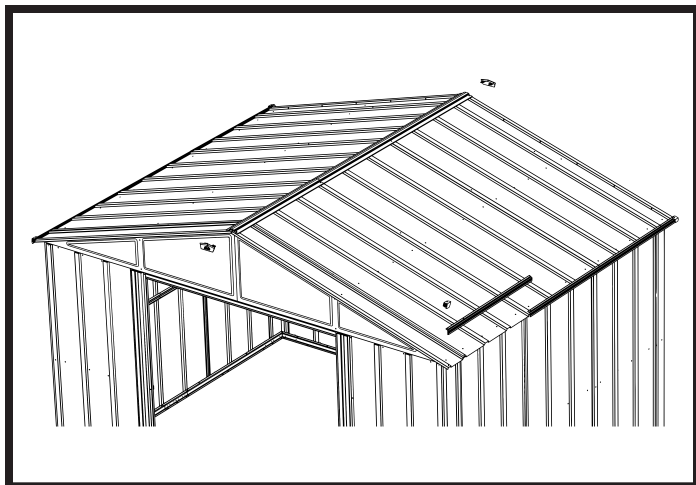

Install Trim

Install the Doors and you now have a finished shed

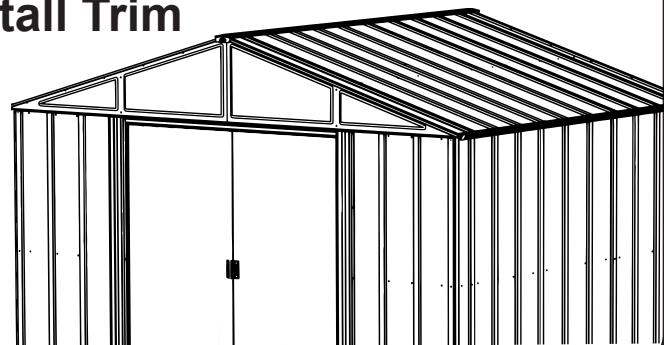

CONSTRUCTING A BASE...

No matter which of the options below you choose for a base, an ARROW ANCHORING KIT is recommended as an effective method of properly securing your building after assembly is complete.

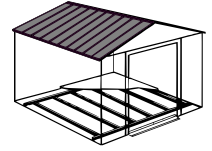

OPTION 1: Directly on ground (earth)

Assemble your building directly on level ground (grass, dirt, rock, sand, etc.). If you choose this option Arrow has a simple kit available to provide a floor **inside** the shed to keep stored items off the ground. This kit can be used to support a plywood floor (wood not included) or be filled with sand/rock to provide a solid surface. (Order No. FB109-A or 68385-A)

Allow 1 - 2 hours for construction.

OPTION 2: Wood Platform

If you decide to build your own base, be sure to select the appropriate materials.

These are the recommended materials for your base:

- 2 x 4's (38 mm x 89 mm) Pressure Treated Lumber • 5/8" (15,5 mm) 4 x 8 (1220 mm x 2440 mm) Plywood-exterior grade
- 10 & 4 penny Galvanized Nails • Concrete Blocks (optional)

NOTE: Pressure Treated Lumber must not be used where it will make contact with your storage building. The properties of Pressure Treated Lumber will cause accelerated corrosion. **If Pressure Treated Lumber comes in contact with your storage building your warranty will be voided.**

The platform should be level and flat (free of bumps, ridges etc.) to provide good support for the building. The necessary materials may be obtained from your local lumber yard.

To construct the base follow instructions and diagram.

- Construct frame (using 10 penny galvanized nails)
- Measure 16"/24" (40,6 cm/61,0 cm) sections to construct inside frame (see diagram)
- Secure plywood to frame (using 4 penny galvanized nails)

Allow 6 - 7 hours for construction.

OPTION 3: Concrete Slab

The slab should be at least 4" (10,2 cm) thick. It must be level and flat to provide good support for the frame.

The following are the recommended materials for your base.

- 1 x 4's (19 mm x 89 mm) (will be removed once the concrete cures)
- Concrete • Sheet of 6 mil plastic
- We recommend for a proper strength concrete to use a mix of:
1 part cement • 3 parts pea sized gravel • 2 1/2 parts clean sand

Prepare the Site/Construct a Base

1. Dig a square, 6" (15,2 cm) deep into the ground (remove grass).
2. Fill up to 4" (10,2 cm) in the square with gravel and tamp firm.
3. Cover gravel with a sheet of 6 mil plastic.
4. Construct a wood frame using four planks of 1x4 (19 mm x 89 mm) lumber.
5. Pour in concrete to fill in the hole and the frame giving a total of 4" (10,2 cm) thick concrete. Be sure surface is level.

Allow 3 - 5 hours for construction and a week for concrete curing time.

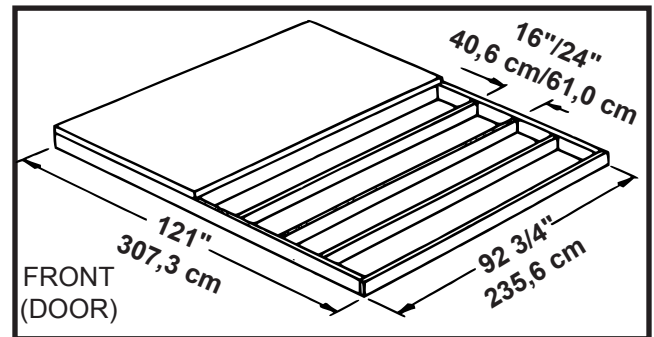

Note: Platform/Slab will extend 9/16" (1,4 cm) beyond floor frame on all four sides. Seal this 9/16" (1,4 cm) of wood with a roofing cement (not included), or bevel this 9/16" (1,4 cm) of concrete when pouring, for good water drainage.

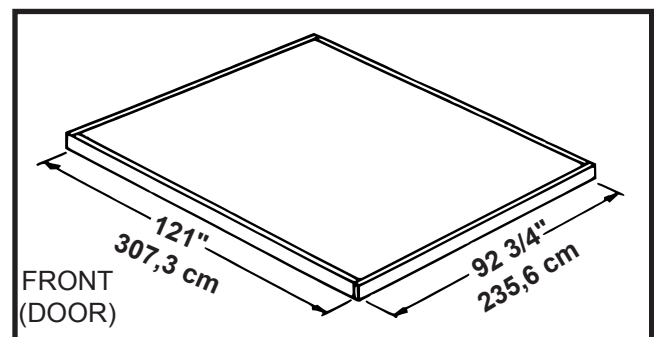

Note: Finished Slab dimensions, with lumber removed.

Step 1: Floor Frames

You will need for this page:

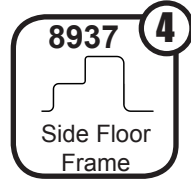
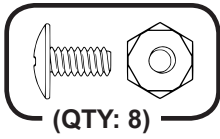

NOTE Washers are to be used on painted parts only. Washers are not necessary on unpainted parts and there are not enough to use on every screw and bolt.

1 Overlap two (2) **Side Floor Frames** as shown and secure with four (4) bolts. Two (2) bolts must enter from bottom.

2 Assemble a second **Side Floor Frame Assembly** by repeating part 1. Check that the finished length of the **Assemblies** is 91 1/8" (231,5 cm). Set aside for use in Step 5.

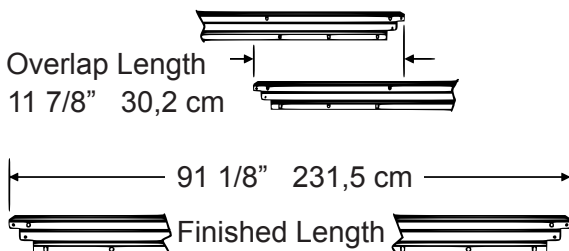
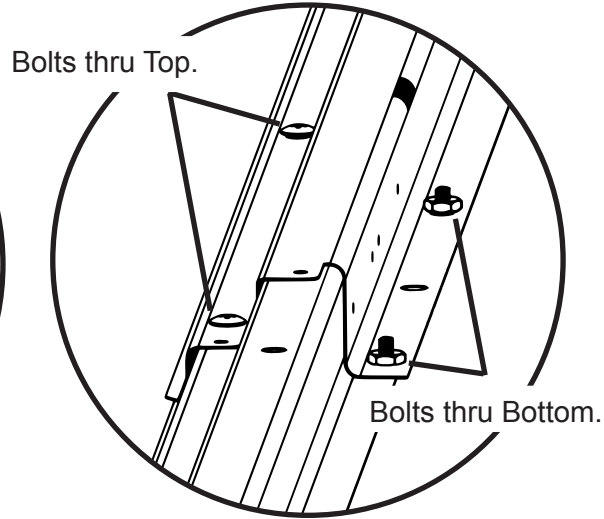
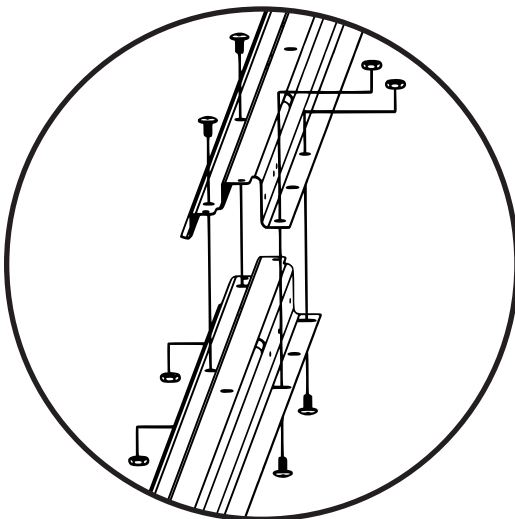
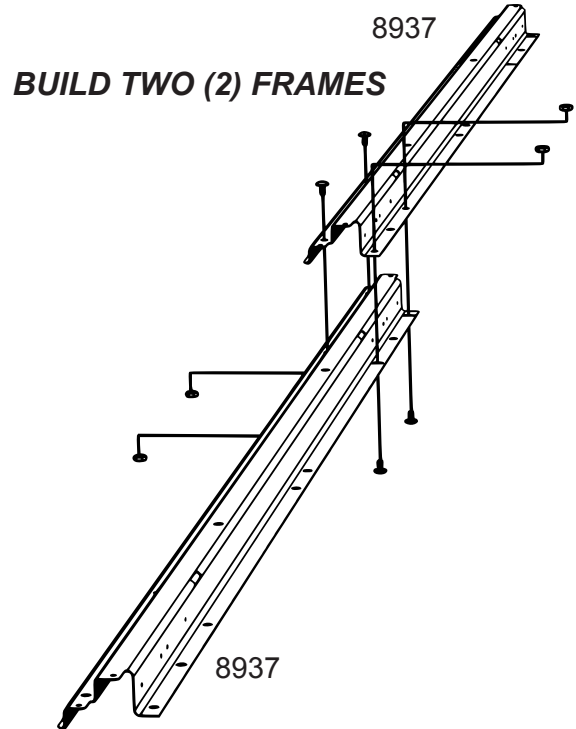

Step 1: Continued

You will need for this page:

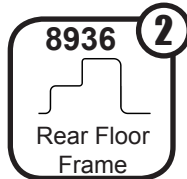
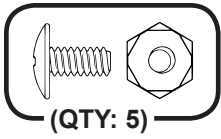

Assemble the Rear Floor Frames.

3 Overlap two (2) **Rear Floor Frames** as shown and secure with five (5) bolts. Two (2) bolts must enter from bottom.

4 Check that the finished length of the **Assembly** is 119 3/8" (303,2 cm). Set aside for use in Step 5.

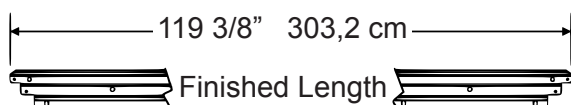
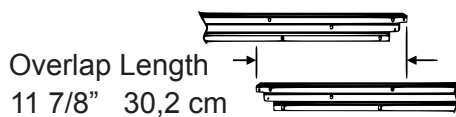
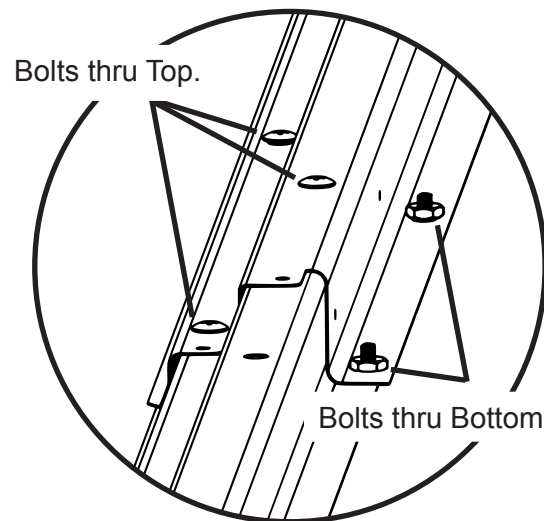
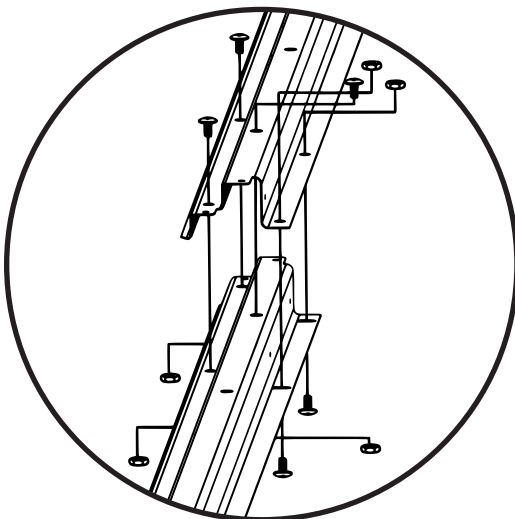
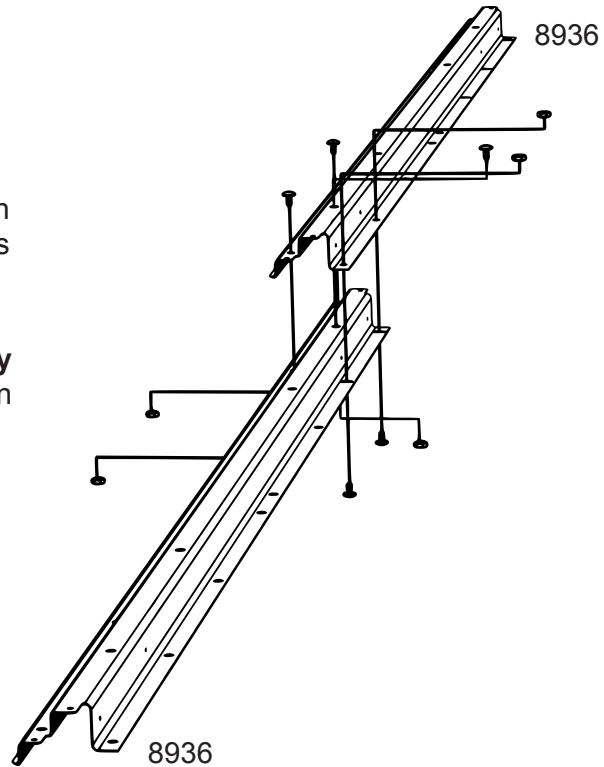

Step 1: Continued

You will need for this page:

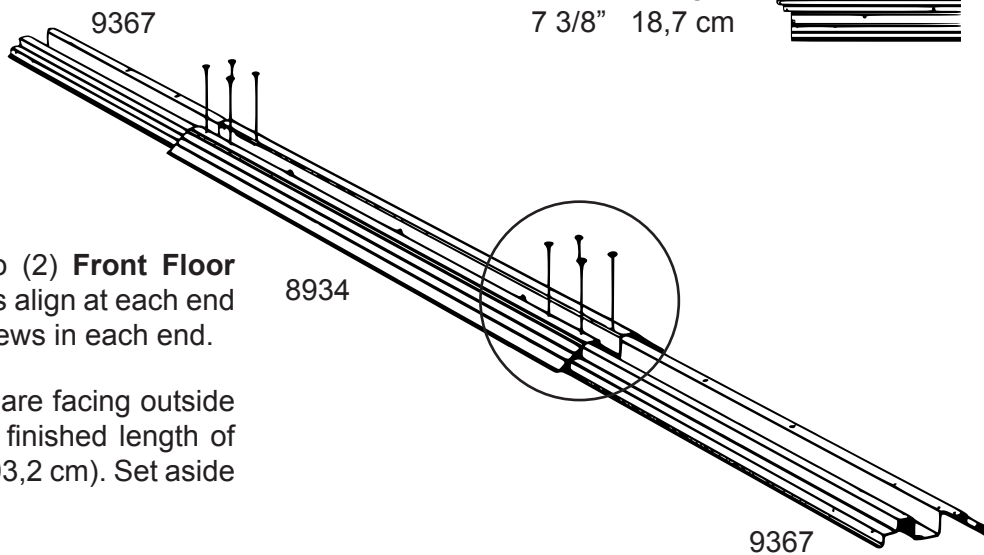
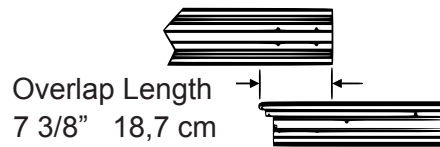
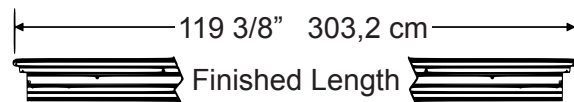
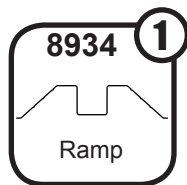
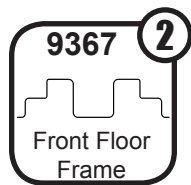
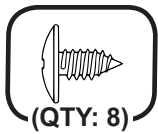

5 Overlap the **Ramp** and two (2) **Front Floor Frames** so that four (4) holes align at each end as shown. Insert four (4) screws in each end.

6 Confirm that the drain holes are facing outside the building. Check that the finished length of the **Assembly** is 119 3/8" (303,2 cm). Set aside for use in Step 5.

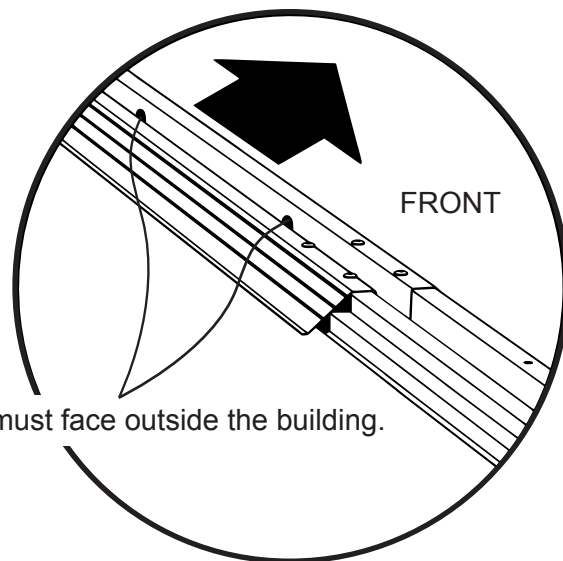
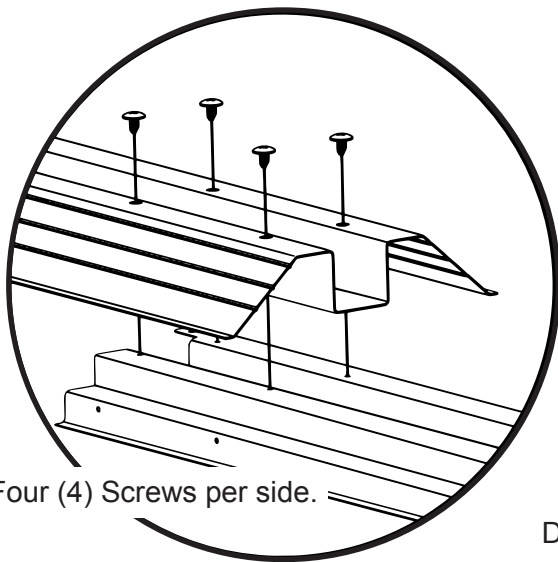

CHECK THAT ALL ASSEMBLED PARTS ARE THE CORRECT LENGTH BEFORE CONTINUING

Step 2: Wall Frames

You will need for this page:

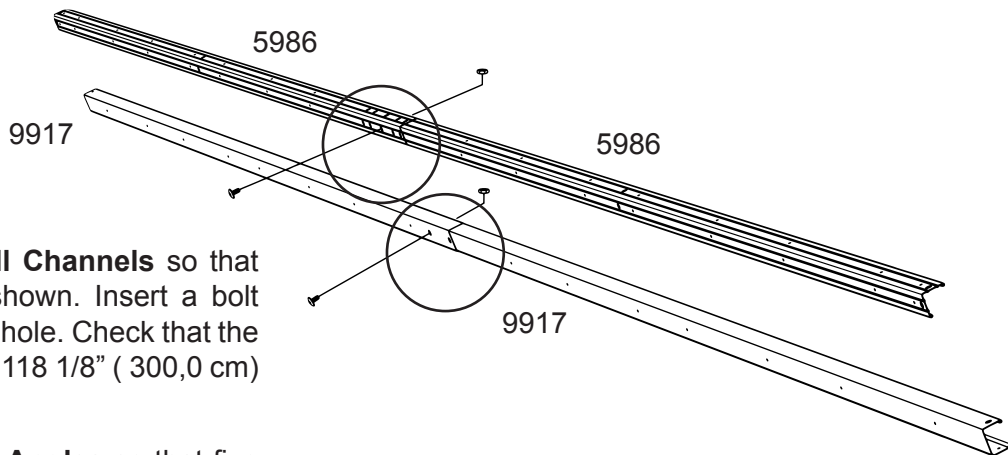
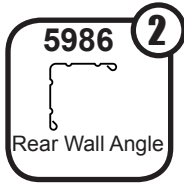
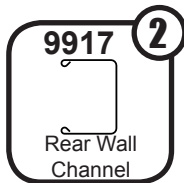
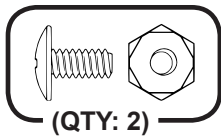

1 Overlap two (2) **Rear Wall Channels** so that three (3) holes align as shown. Insert a bolt and nut through the center hole. Check that the finished length of the **Assembly** is 118 1/8" (300,0 cm) set aside for use in Step 10.

2 Overlap two (2) **Rear Wall Angles** so that five (5) holes align as shown. Insert a bolt and nut through the center hole. Check that the finished length of the **Assembly** is 118 1/8" (300,0 cm) set aside for use in Step 7.

Slide parts together until five (5) holes align.

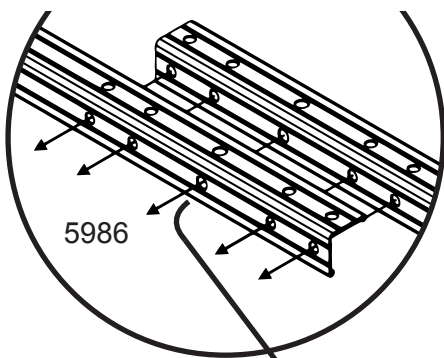

Slide parts together until three (3) holes align.

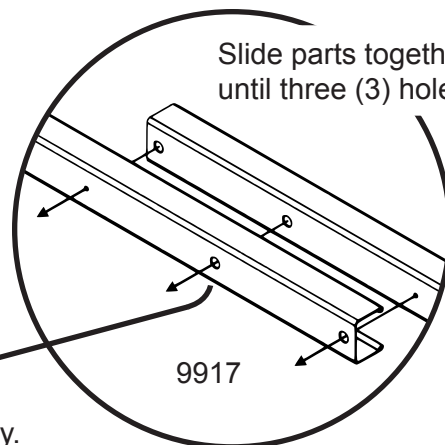

Overlap Length
6 1/8" 15,6 cm

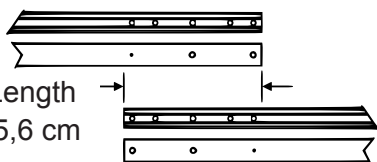

Place bolt thru center hole only.

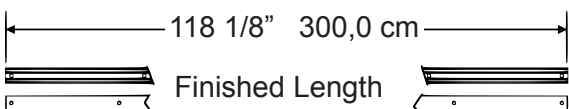

Step 2: Continued

You will need for this page:

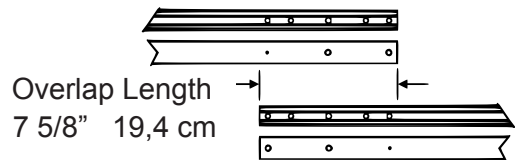
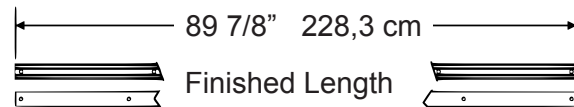
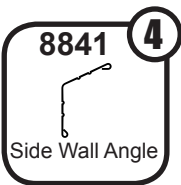
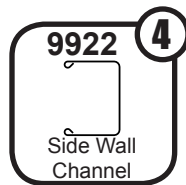
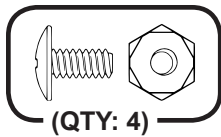

3 Overlap two (2) **Side Wall Channels** so that three (3) holes align as shown. Insert a bolt and nut through the center hole. Check that the finished length of the **Assembly** is $89 \frac{7}{8}$ " (228,3 cm) set aside for use in Step 10.

4 Overlap two (2) **Side Wall Angles** so that five (5) holes align as shown. Insert a bolt and nut through the center hole. Check that the finished length of the **Assembly** is $89 \frac{7}{8}$ " (228,3 cm) set aside for use in Step 7.

5 Repeat Parts 1 & 2 to build a second set of each assembly.

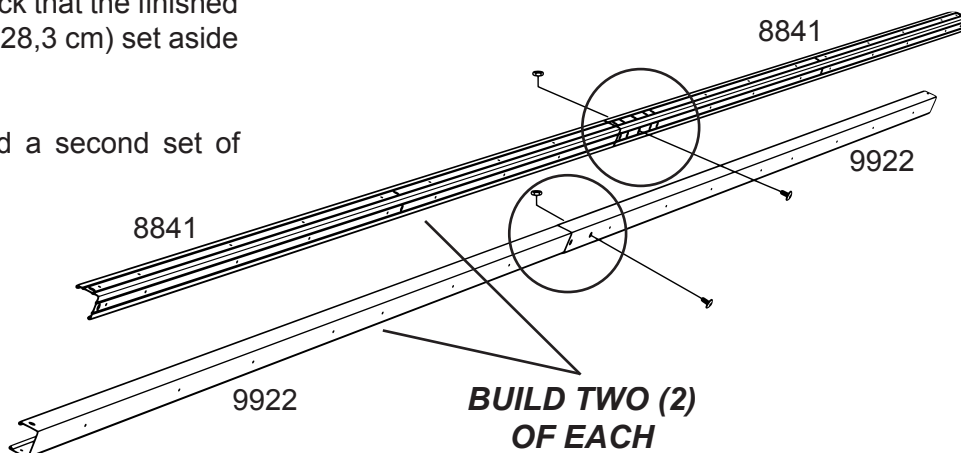

Slide parts together until five (5) holes align.

Slide parts together until three (3) holes align.

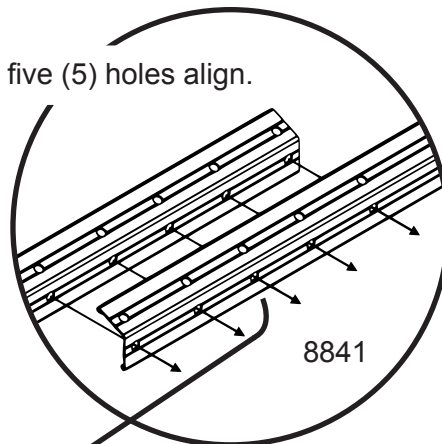
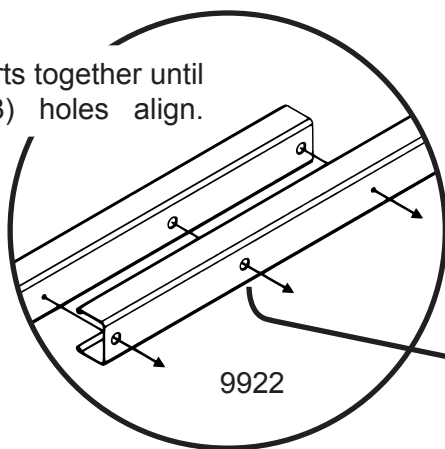

Place bolt and nut thru center hole only.



CHECK THAT ALL ASSEMBLED PARTS ARE THE CORRECT LENGTH BEFORE CONTINUING

Step 3: Roof Beams

You will need for this page:

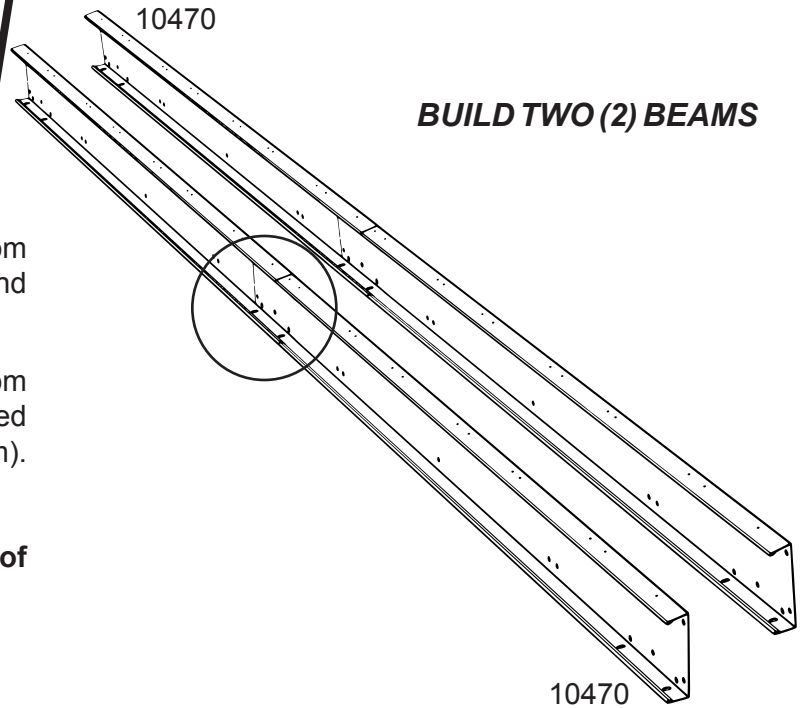
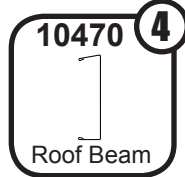
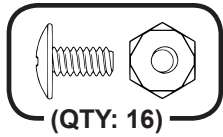

1 Overlap two (2) **Roof Beams** so that the bottom slots align as shown. Insert six (6) bolts and nuts as shown below.

2 Insert two (2) bolts and nuts into slots on bottom of the **Beam** as shown. Check that the finished length of the **Assembly** is 91 7/8" (233,4 cm). Set aside for use in Step 12.

3 Repeat parts 1 & 2 to build a second **Roof Beam Assembly**.

Slide parts together until the bottom slots align.

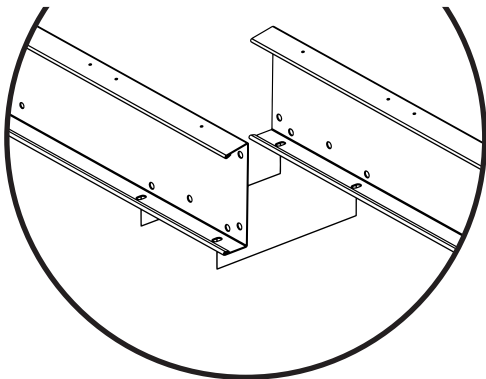

Insert six (6) bolts into holes.

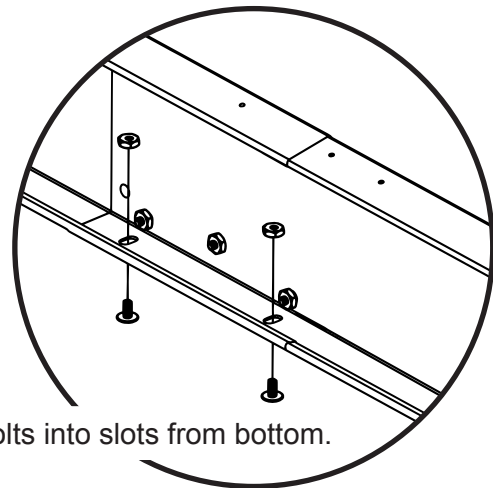

Insert bolts into slots from bottom.

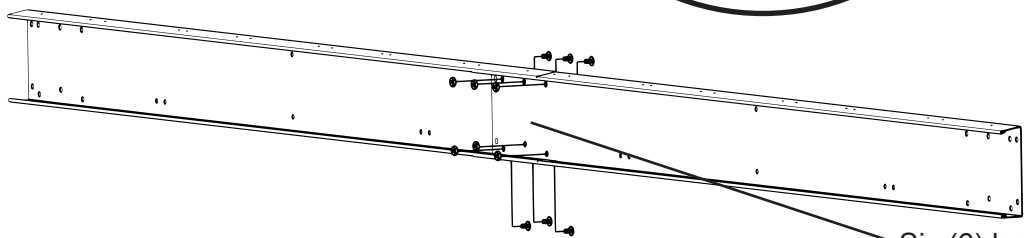

Six (6) holes align.

Overlap Length
6" 15,2 cm

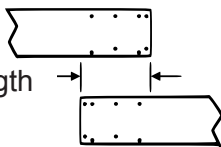

91 7/8" 233,4 cm

Finished Length

Step 3: Continued

You will need for this page:

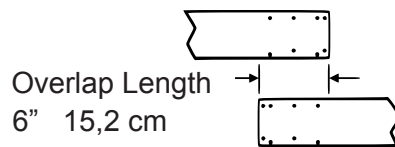
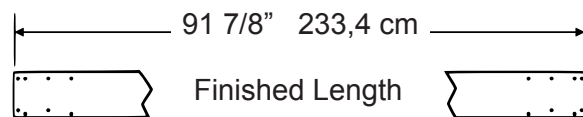
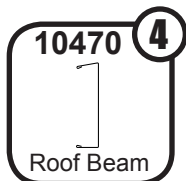
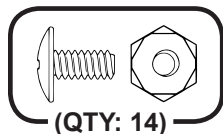

4 Overlap two (2) **Roof Beams** so that bottom slots align but **DO NOT INSERT BOLTS**. Next, overlap two (2) more **Roof Beams** to form a second **Roof Beam Assembly**. **DO NOT INSERT BOLTS**.

5 Place both **Roof Beam Assemblies** back-to-back to form a **Double Beam**. Insert ten (10) bolts and nuts as shown below.

6 Insert four (4) bolts and nuts into slots from bottom. Check that the finished length of the **Assembly** is 91 7/8" (233,4 cm). Set aside for use in Step 12.

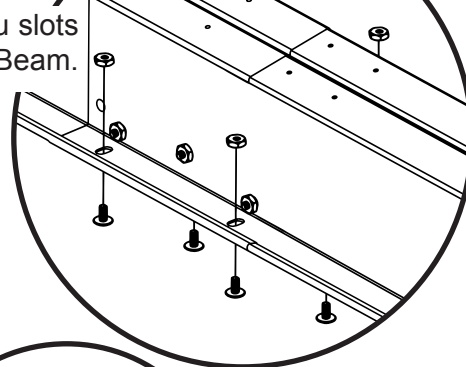
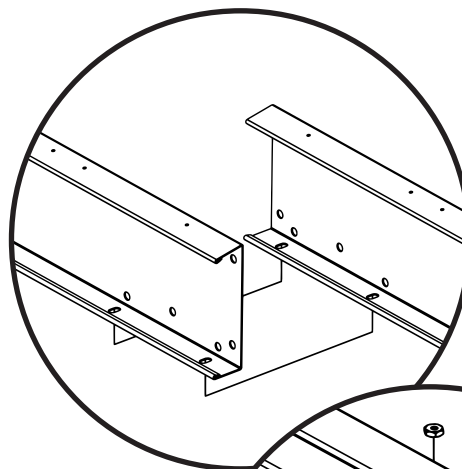

Place two (2) bolts thru slots on each side of the Beam.

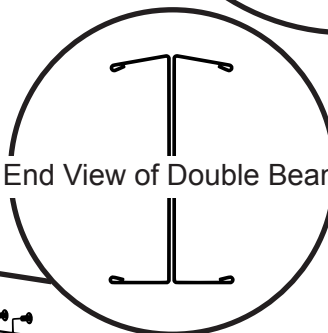

End View of Double Beam

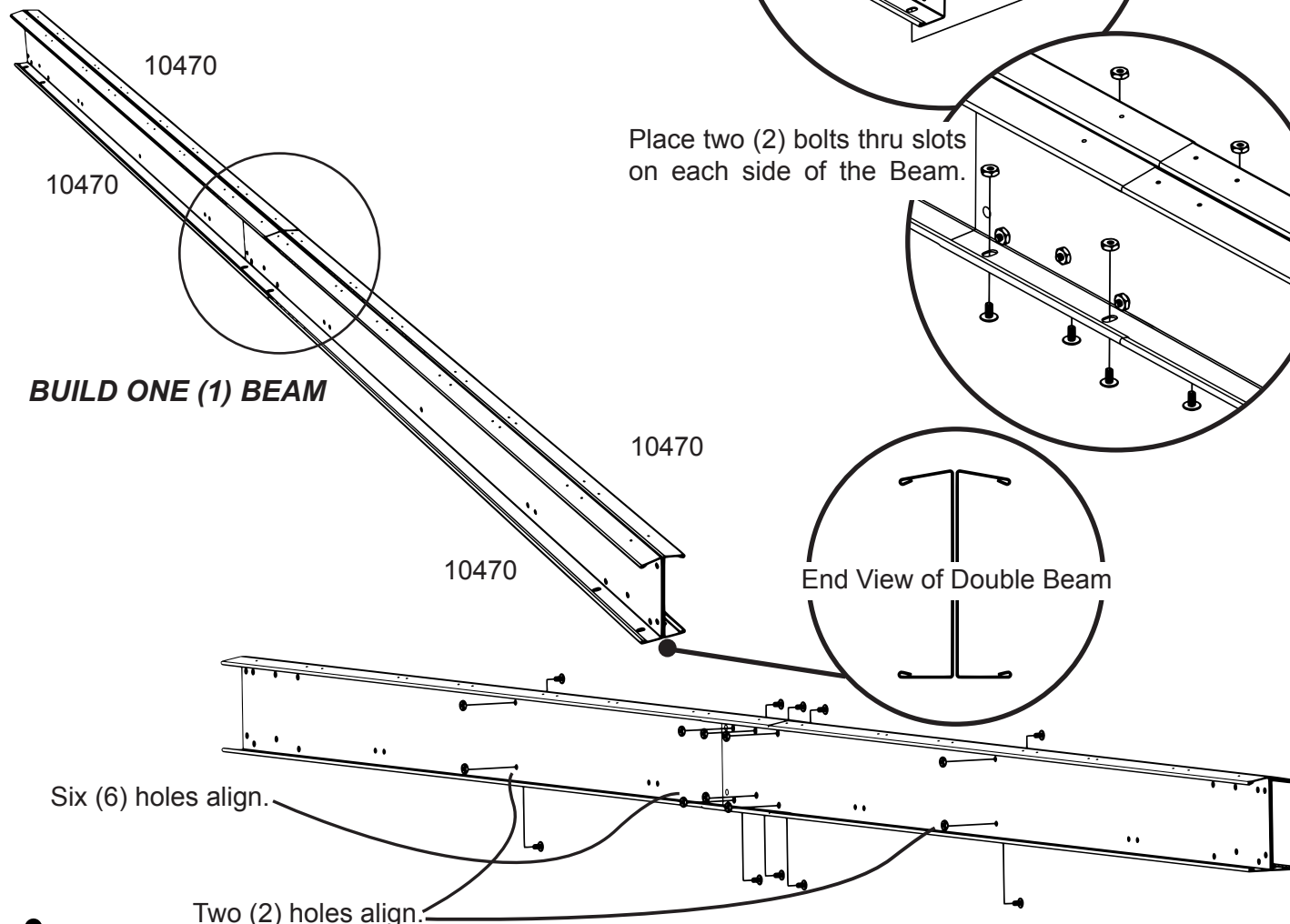

Six (6) holes align.

Two (2) holes align.



CHECK THAT ALL ASSEMBLED PARTS ARE THE CORRECT LENGTH BEFORE CONTINUING

Step 4: Door Track

You will need for this page:

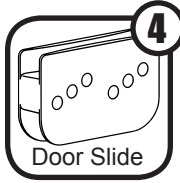

END VIEW

CORRECT

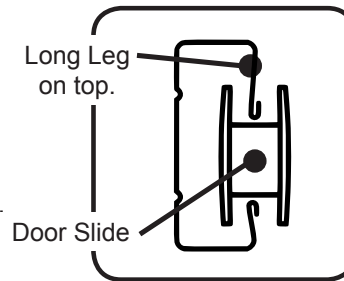

INCORRECT

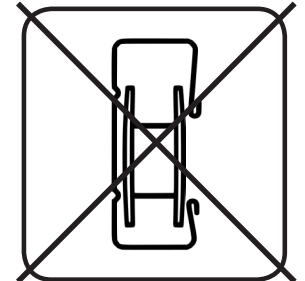

NOTE Insert screws into bottom side only. The Gables will fasten to the Door Track using the holes on the top side.

1 Align two (2) **Door Tracks** with the four (4) holes in the bottom of the **Door Track Splice** and insert four (4) screws.

2 Position the **Door Slides** in the **Door Track**. Check that the finished length is 118 1/8" (300,0 cm). Set aside for use in Step 7.

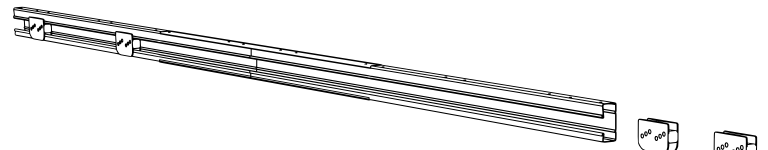

Slide all four (4) Door Slides into Track.

NOTE The bottom side of the Door Tracks and the Door Track Splice has only four (4) holes. The top side has many holes. Fasten bottom side only.

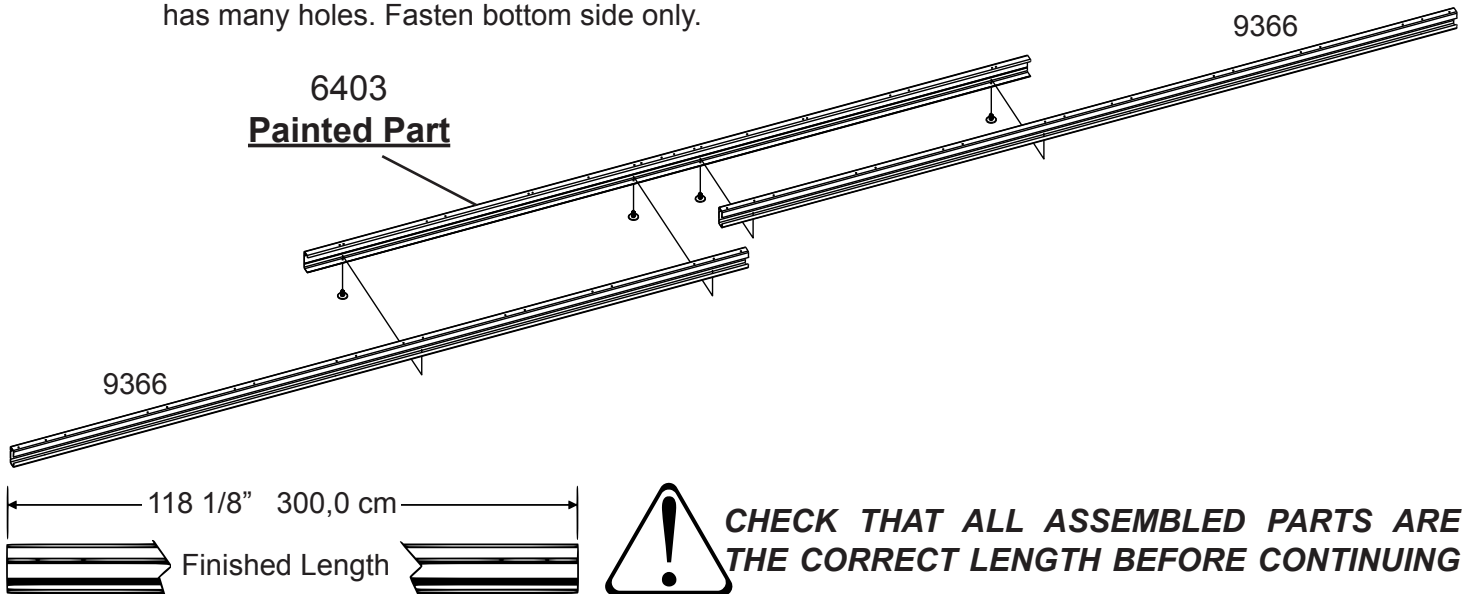

NOTE Slides should be installed in Door Track prior to installation. However, if this step is overlooked or if the Slides need to be removed for maintenance, the following procedure may be used.

To remove or install Door Slides:

- Remove Doors from Slides and set aside.
- Using pliers, bend down a corner of the Door Track.
- Remove or install Door Slides.
- Carefully bend the corner back into position.

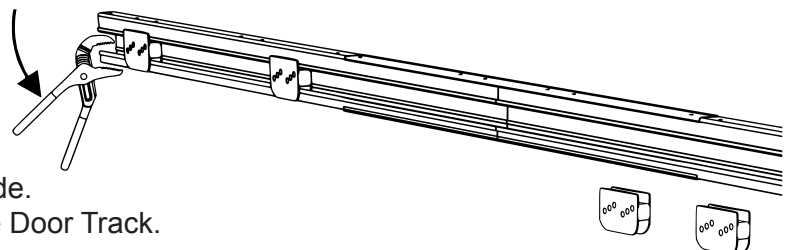

Step 5: Frame Assembly

You will need for this page:

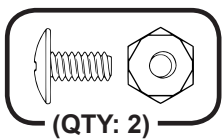
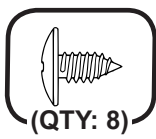

Assemblies from Step 1:

- Front Floor Assembly (1)
- Side Floor Assembly (2)
- Rear Floor Assembly (1)

NOTE Do NOT fasten your Floor Frames to your Base at this time. You will anchor your building after it is erected. If using a Floor Frame Kit, you must wait until after assembly to install it.

1 Assemble Floor Frame with two screws at each corner as shown. At the front corners insert a bolt through the bottom of the Frame as shown.

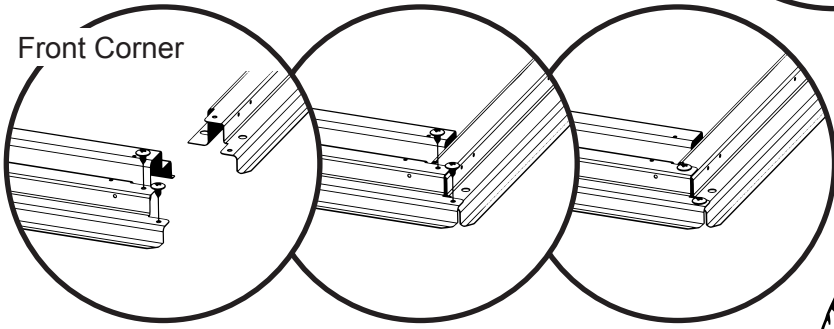
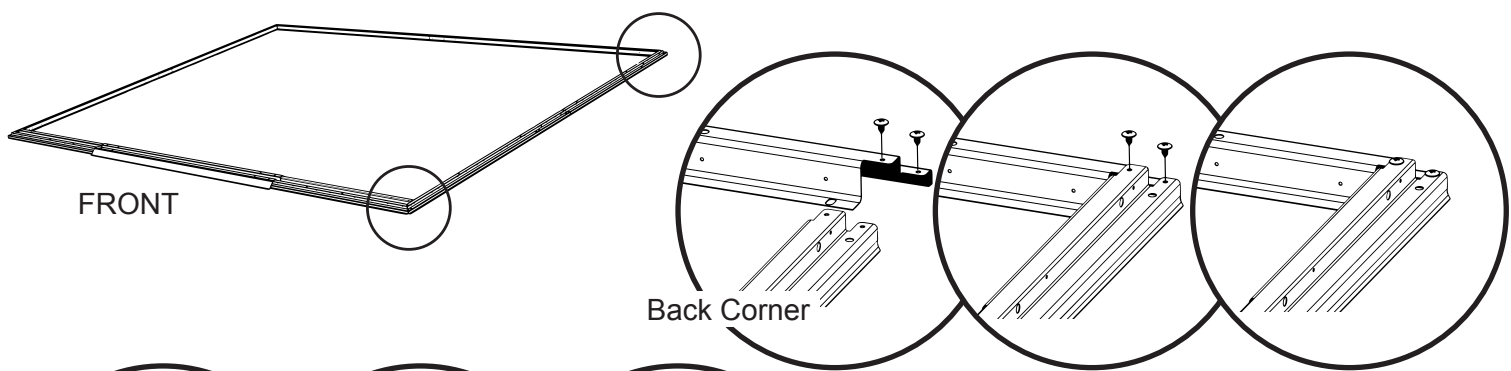

When diagonal measurements are equal, the Frame is square.

Insert a bolt and nut thru bottom of Front Floor Frame at each front corner to secure Front Frame to Side Frames.

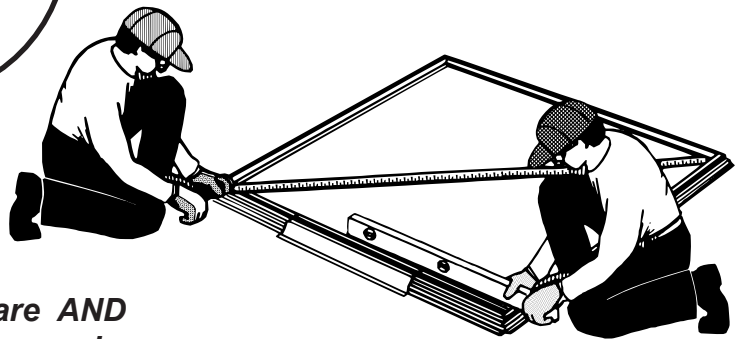

The Floor Frame must be BOTH square AND level or the holes will not line up properly.

NOTE Do not continue beyond this point unless you have enough time to complete the shed today. The remainder of assembly may take several hours and requires at least two people. A partially assembled shed left overnight can be seriously damaged by even light winds. It is recommended that you wait and complete the remainder of shed assembly on a day which you have plenty of time to finish the shed safely and completely.

Step 6: Corners

You will need for this page:

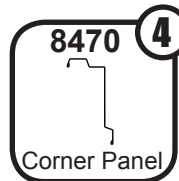
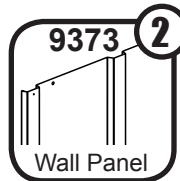
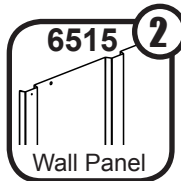
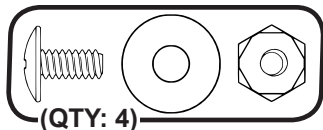
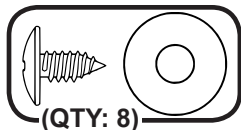

NOTE

Place washers on all bolts and screws used on painted parts.

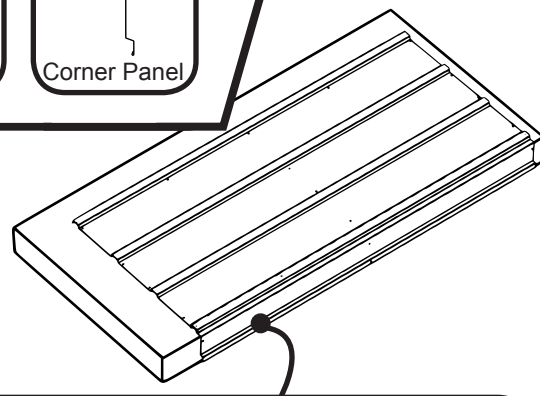

1 Position **Front** and **Rear Wall Panels** so that they overlap the narrow side of the **Corner Panels** as shown.

2 Secure **Panels** with a screw in the top and bottom of each **Panel**. Insert a bolt and nut through the middle hole of each **Panel**.

The best way to assemble the Corners is on a flat, elevated surface such as a table or workbench. If one of these is not available to you, you can support the Corner Panel and Wall Panel on the carton your shed was shipped in. Position the Panels as shown and insert screws.

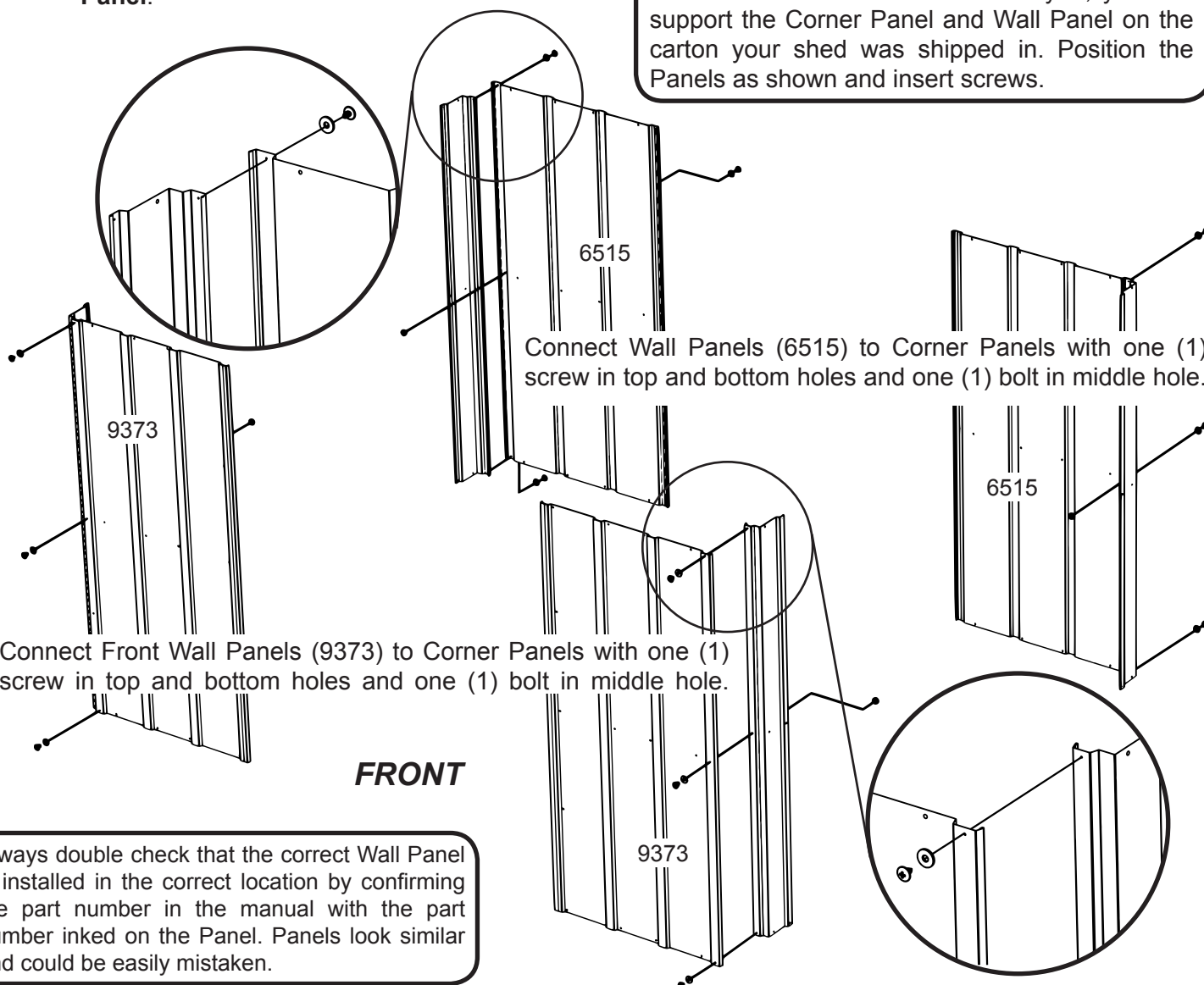

Always double check that the correct Wall Panel is installed in the correct location by confirming the part number in the manual with the part number inked on the Panel. Panels look similar and could be easily mistaken.

Step 6: Continued

You will need for this page:

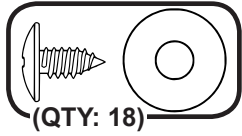

Be cautious when maneuvering and placing Panels. Once Panels begin to go up it is important to be able to finish in a timely manner to reduce the possibility of wind damage to your building.



3 Working one **Corner** at a time, attach the assembled **Corners** to the **Floor Frame** in the position shown.

4 Place screws through all holes along the bottom of the **Panels**, but leave the hole closest to the **Ramp** open in each **Front Panel** as shown below.

NOTE Use one person to support the Corner while another secures the Panels. Do not leave the Corner unsupported until it is secure.

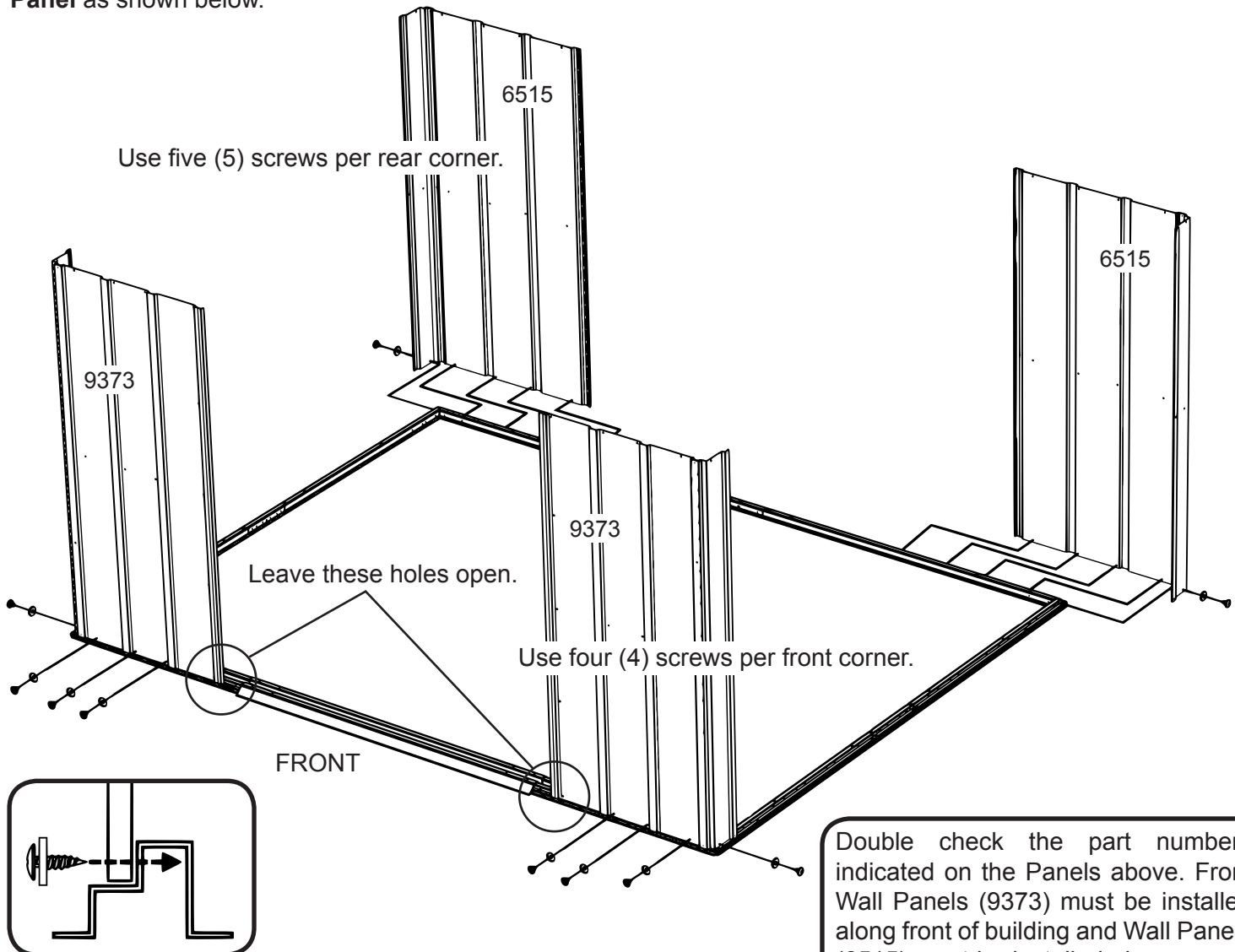

Wall Panels ALWAYS attach to the Floor Frames with screws in the manner shown above. Rest the panel on the Floor Frame and the holes in the Panel should line up with the holes in the frame.

Double check the part numbers indicated on the Panels above. Front Wall Panels (9373) must be installed along front of building and Wall Panels (6515) must be installed along rear of building.

Step 7: Wall Framing

You will need for this page:

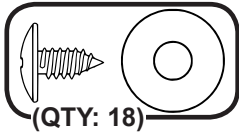

Assemblies from Step 2 and Step 4:

- Rear Wall Angle Assembly (1)
- Side Wall Angle Assemblies (2)
- Door Track Assembly (1)

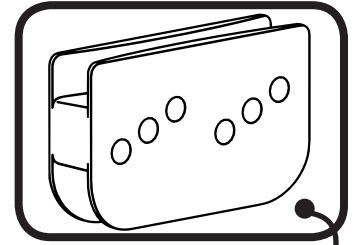

- Install one **Side Wall Angle Assembly** first.
 - Install the **Rear Wall Angle Assembly** second.
 - Install the other **Side Wall Angle Assembly** third.
 - Install the **Door Track Assembly** last.
- Door Slides should be in Door Track at this time.

- Use the number of screws shown. Leave the hole closest to the **Ramp** open in each **Front Panel** as shown above.

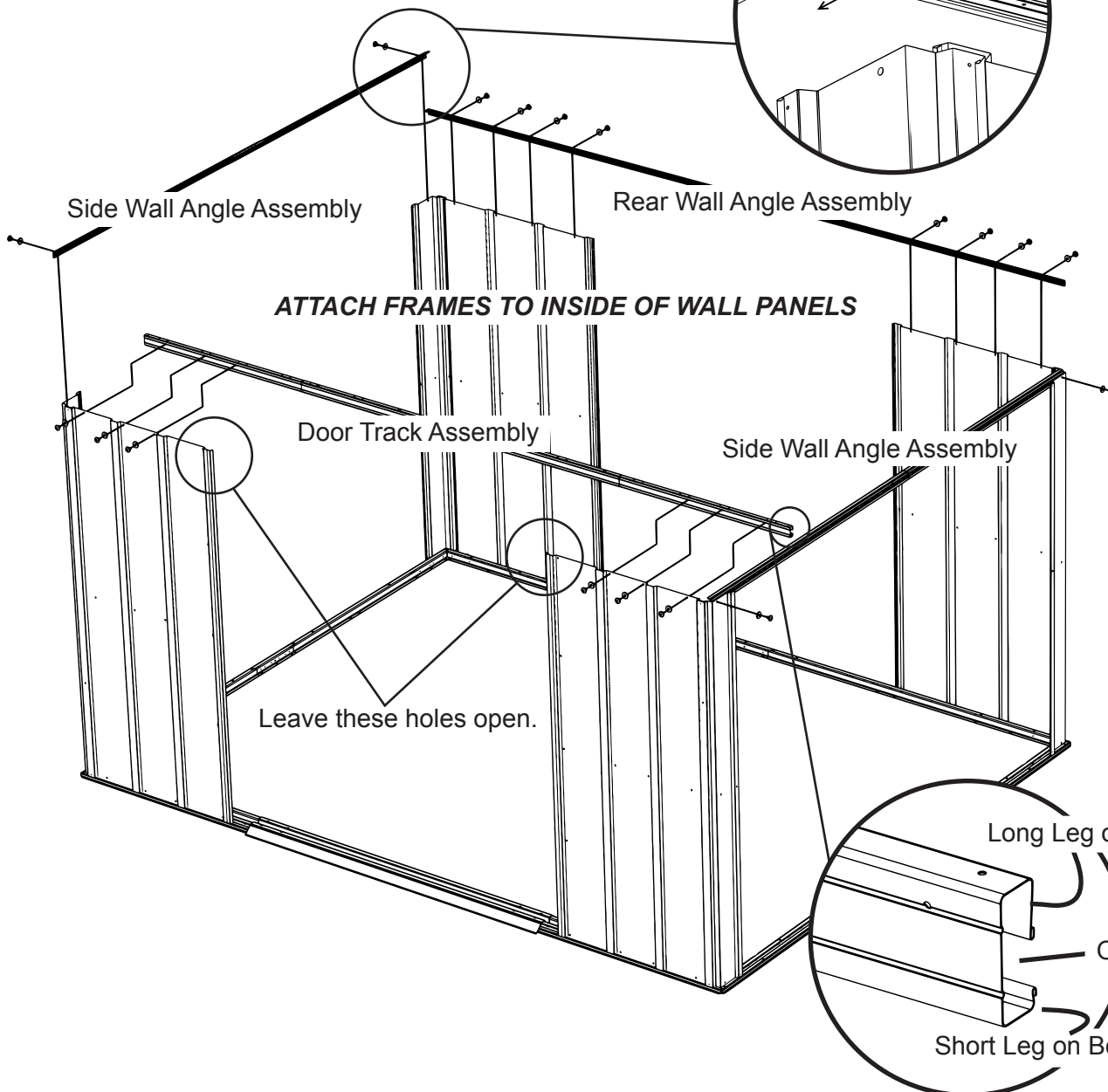
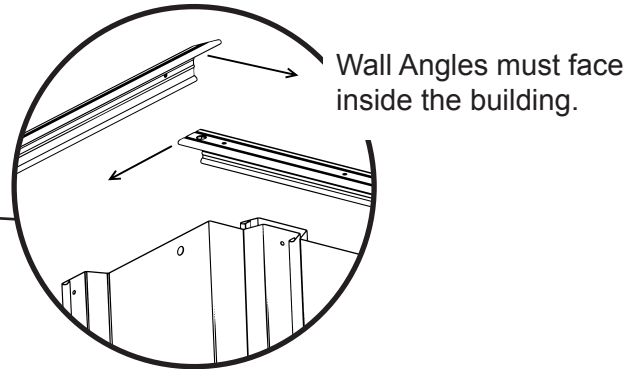

Step 8: Wall Panels

You will need for this page:

[NO HARDWARE NEEDED
FOR THIS STEP]

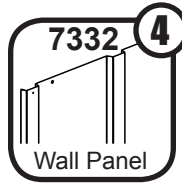
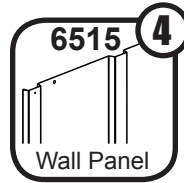

- 1** Lay out all **Panels** in the positions shown below. Double check that you have the correct **Panel** in each location.

NOTE

Use the diagram to the right when attaching Wall Panels.

- Secure the top row to Wall Angles.
- Secure the middle row to Wall Channels (Step 10).
- Secure the lower row to Floor Frames.
- Secure the circled holes to the Panel next to it.

FASTEN TO WALL ANGLES

FASTEN TO WALL CHANNELS (STEP 10)

FASTEN TO FLOOR FRAMES

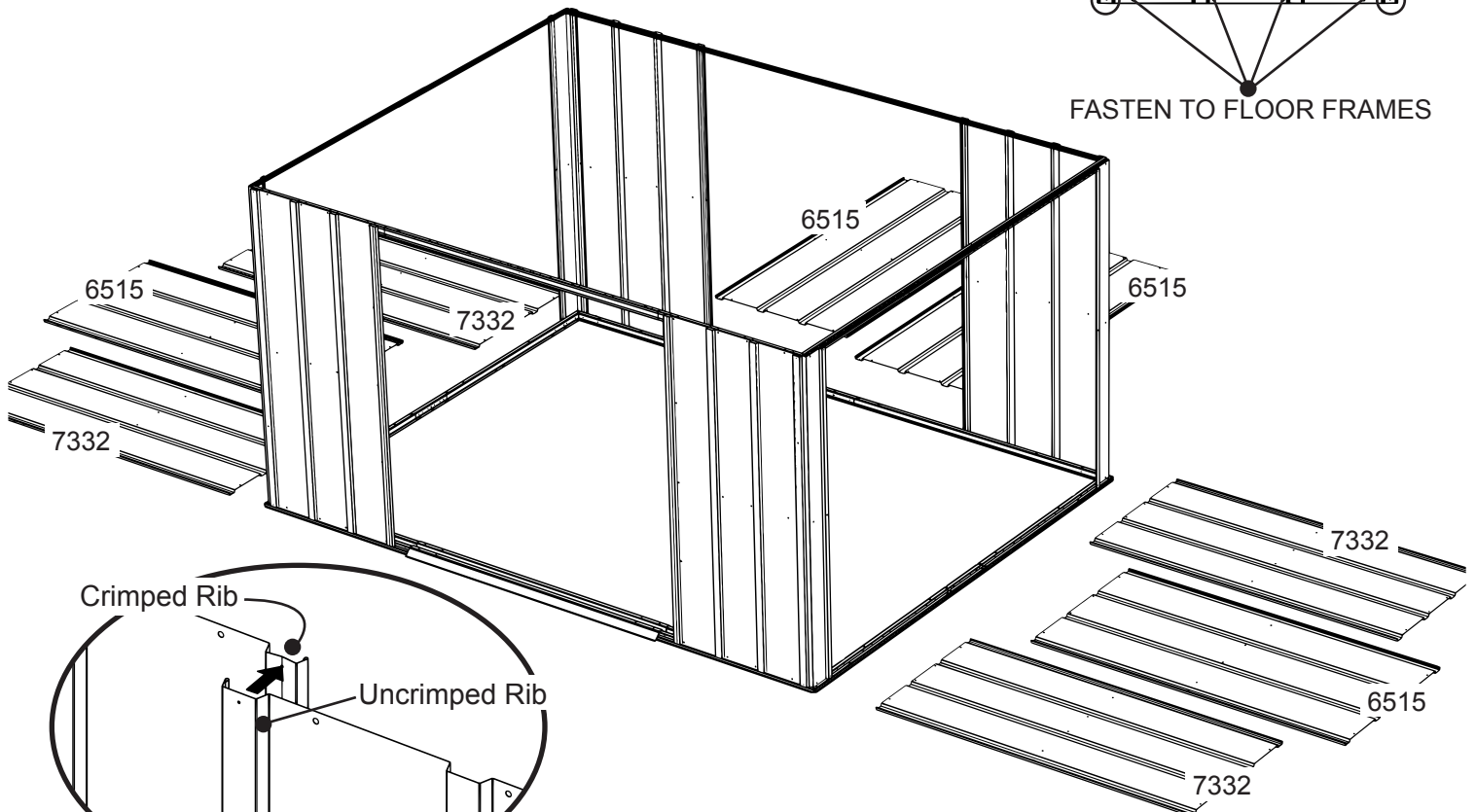

Whenever a crimped rib and an uncrimped rib meet, the crimped rib should be placed UNDER the uncrimped rib if possible.

Step 8: Continued

You will need for this page:

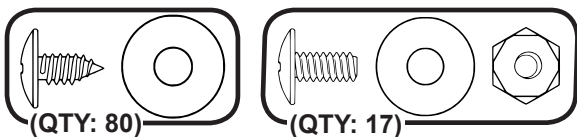

2 Working one side at a time, lift the **Panels** into place and secure top and bottom of **Panels** with screws. Be sure to overlap ribs as shown on the previous page.

3 Place a bolt and nut through the center hole of the **Panel** everywhere **Panels** overlap, as shown below.

Use bolts to attach Wall Panels where Wall Angles overlap.

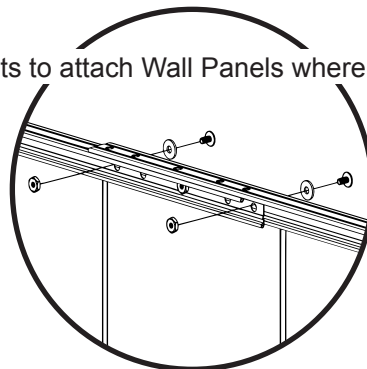

Attach Wall Panels with screws thru all holes in top and bottom of Panels.

Corner Panel

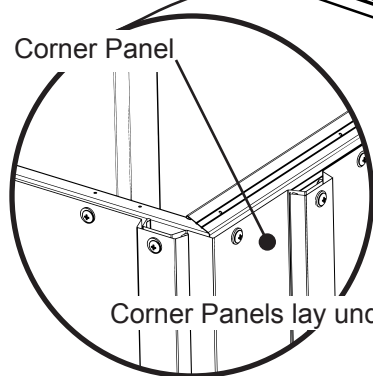

Corner Panels lay under Front and Side Panels.

Place bolt thru center hole where Panels overlap.

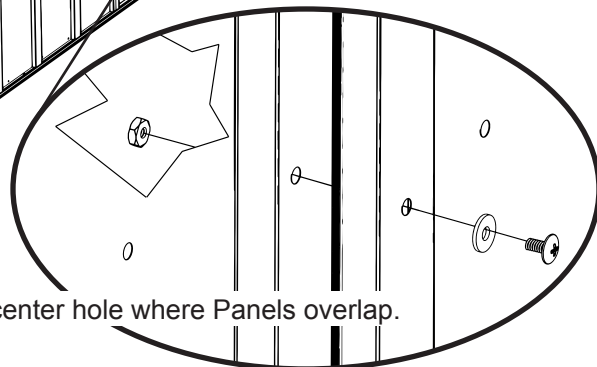

Step 9: Door Jambs

You will need for this page:

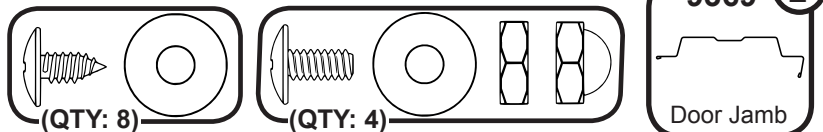

- 1** Secure **Door Jambs** with two (2) screws in the top and bottom of each **Panel** as shown.
- 2** Insert two (2) bolts and nuts into the back side of each **Panel** as shown below. Secure the bolts with both a standard nut and an acorn nut.
- 3** Leave the holes in the center of each **Door Jamb** open as shown below.

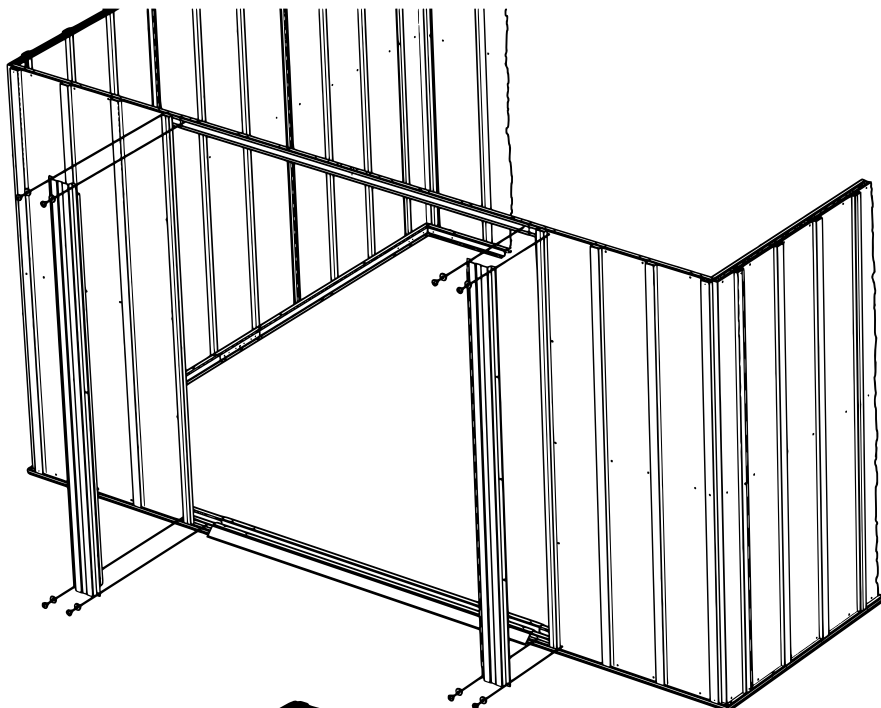

Acorn nut should be visible from outside building.

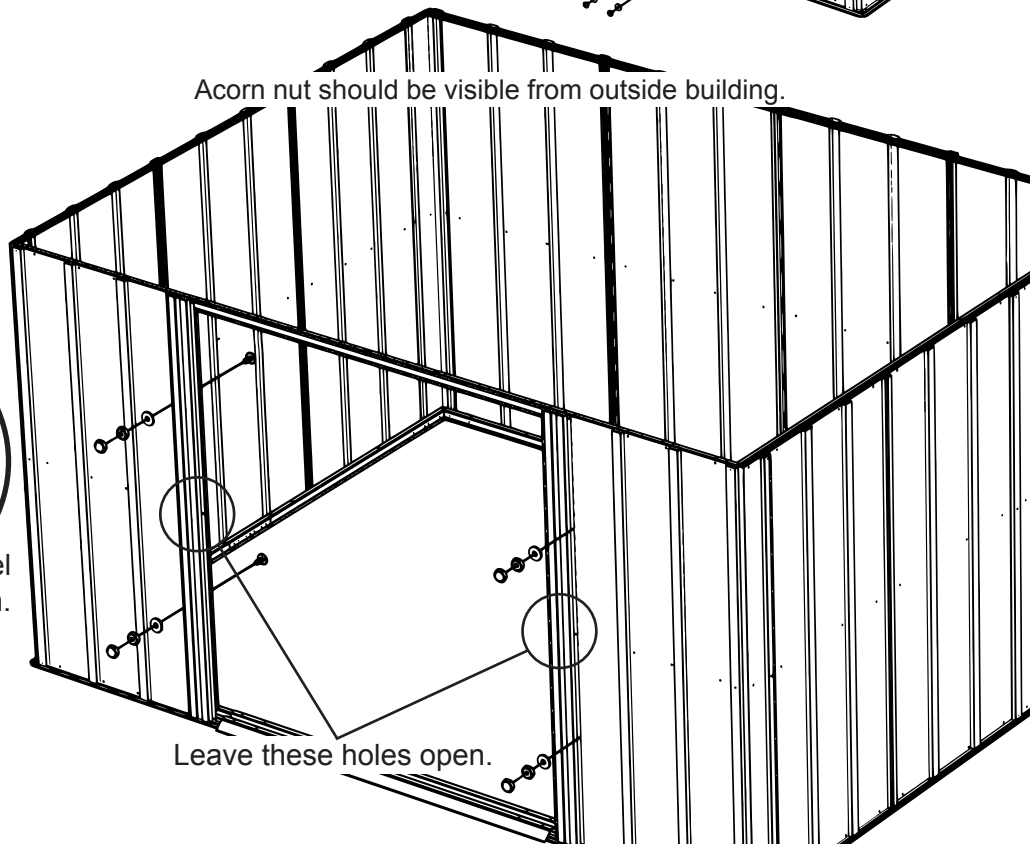

Leave these holes open.

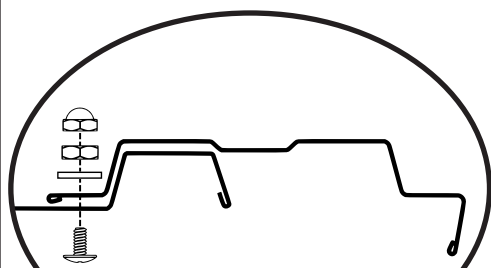

Bolt must go thru back side of Panel or they may interfere with Door action.

Step 10: Wall Channels

You will need for this page:

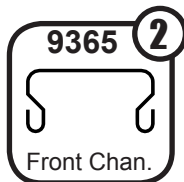
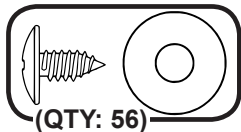

Assemblies from Step 2:

- Rear Wall Channel Assembly (1)
- Side Wall Channel Assemblies (2)

- 1 Install **Rear Wall Channel** by placing screws through all remaining holes in **Wall Panels**.
- 2 Install **Side Wall Channels** by placing screws through all remaining holes in **Wall Panels**.
- 3 Install **Front Wall Channels** by placing screws through all remaining holes in **Wall Panels**. Insert a screw in both rear corners where **Side and Rear Wall Channels** meet.

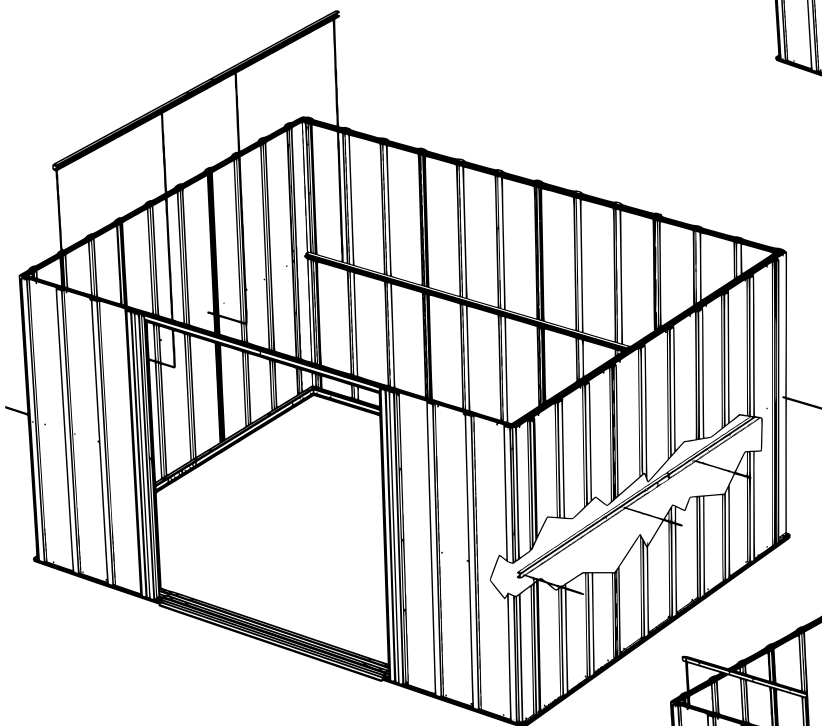
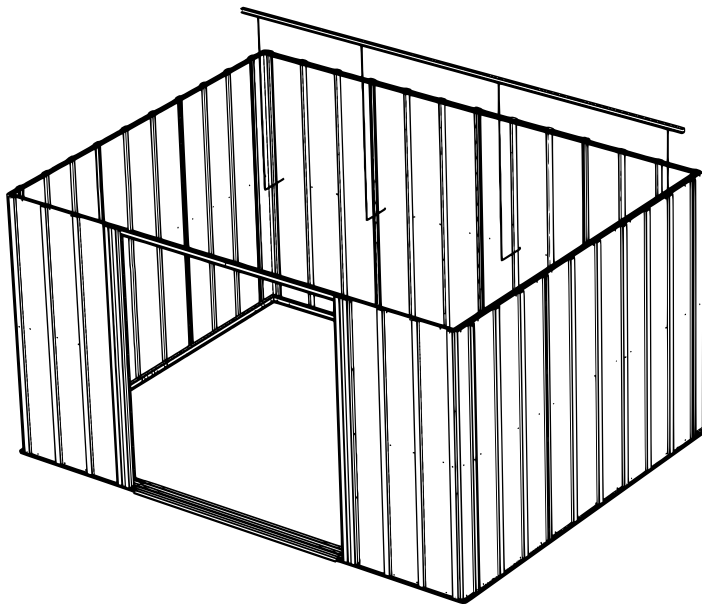

Insert screw where Channels meet.

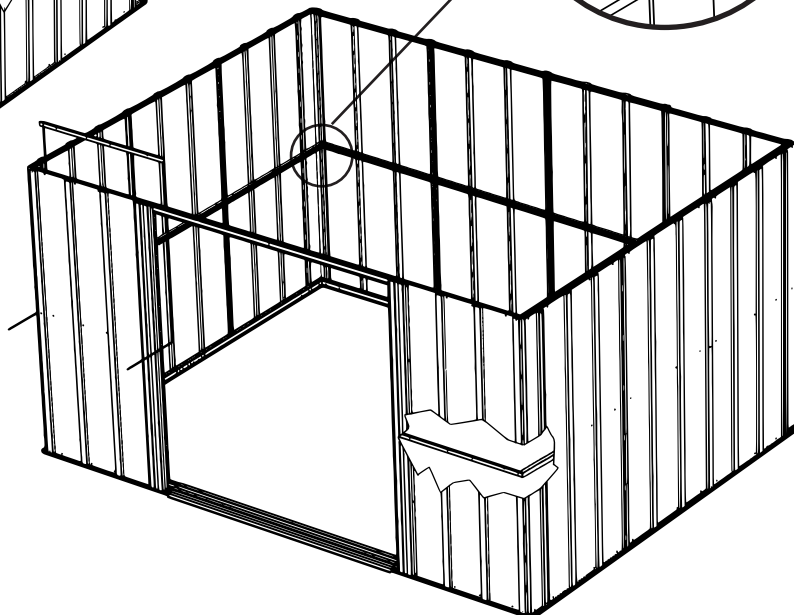
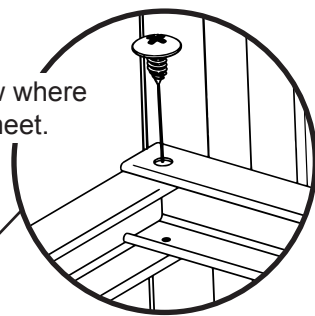

Install Channels on inside of building.

Step 11: Gables

You will need for this page:

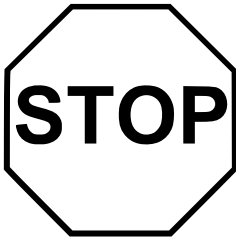
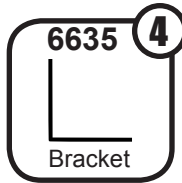
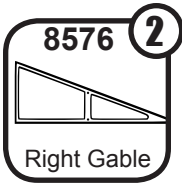
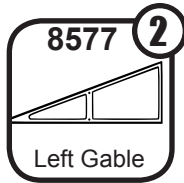
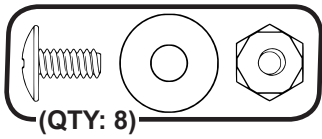

GABLES ARE STACKED TOGETHER DURING SHIPPING AND MAY BE MISTAKEN FOR ONE GABLE! SEPARATE GABLES BEFORE CONTINUING.

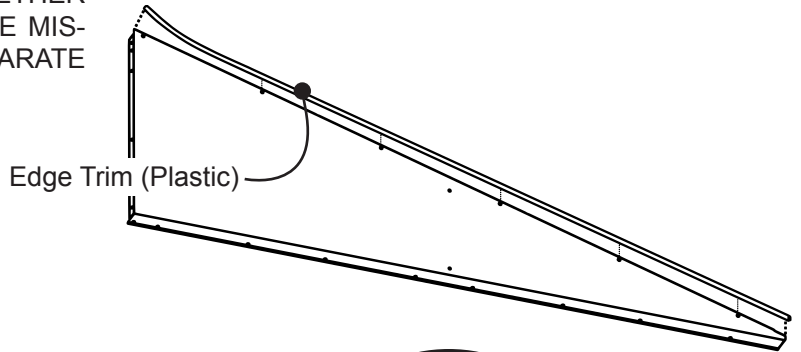
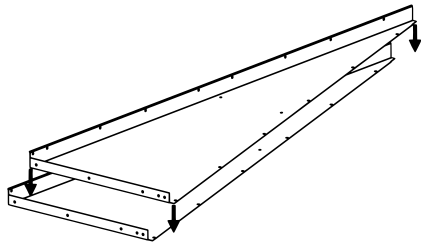

Edge Trim MUST cover Gable edge.

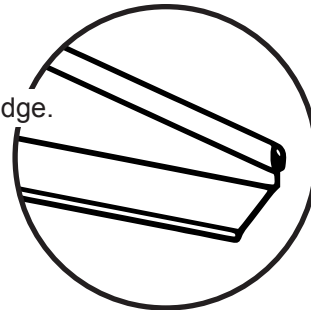

Install Edge Trim to cover Gable Edge BEFORE doing ANY work with Gables. Failure to do so could result in injury.

1

Install **Roof Beam Brackets** on all **Gables** using two (2) bolts and nuts per **Bracket**. Leg of **Bracket** must face center of **Gable** as shown.

Leg of Roof Beam Bracket must face center of Gable as shown.

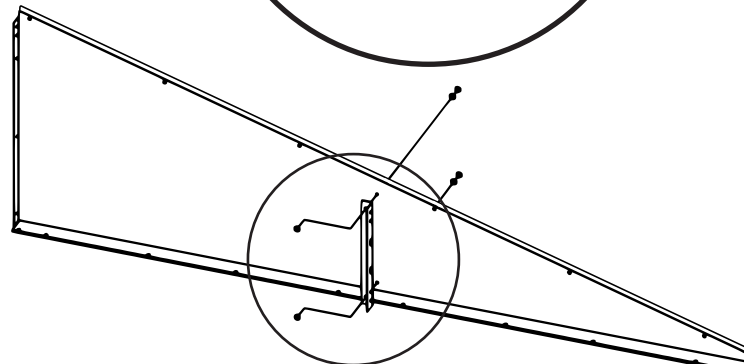
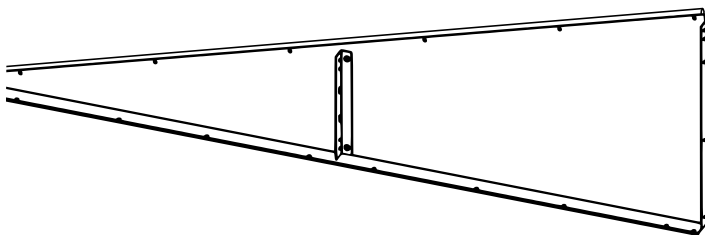
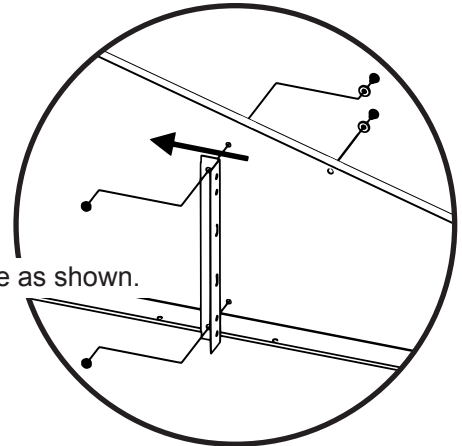

Step 11: Continued

You will need for this page:

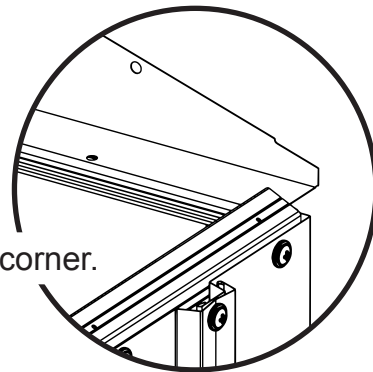
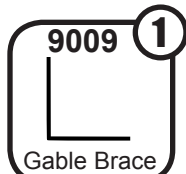
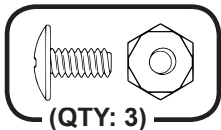
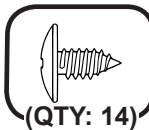

Gable must fit UNDER Side Wall Angle at corner.

2 Working with one **Gable** at a time, attach the **Rear Gables** to the **Rear Wall Angle** with screws.

3 Insert two (2) bolts and nuts where **Wall Angles** overlap.

4 To secure **Gables** together, position the **Gable Brace** as shown and insert a single bolt and nut through the second hole from the bottom only.

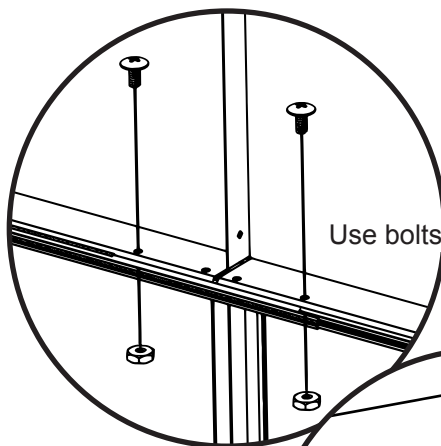
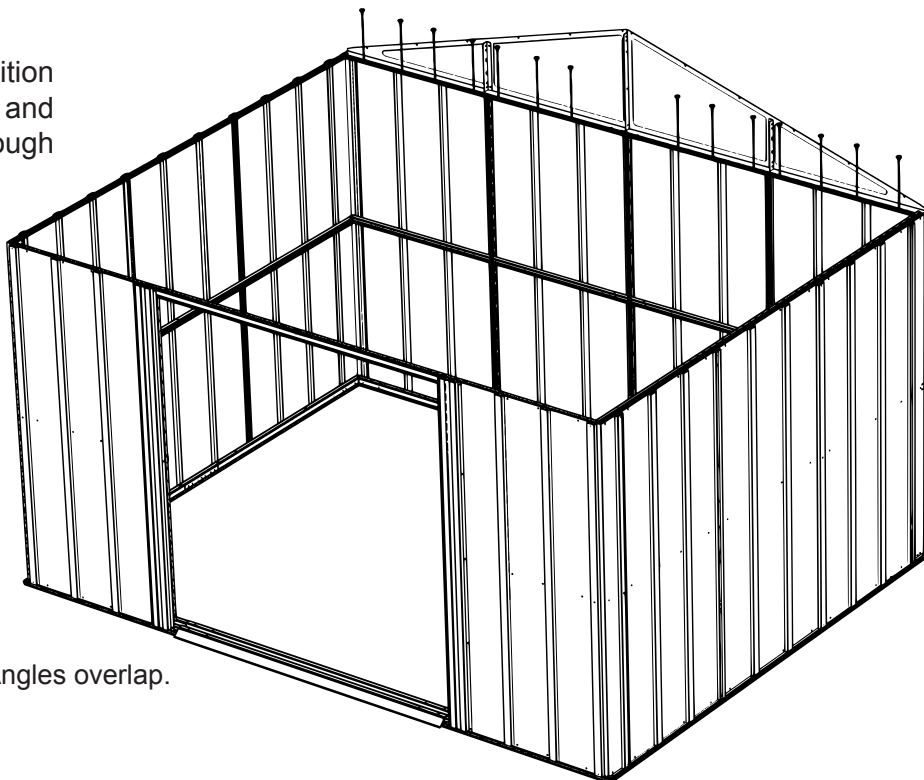

Use bolts where Angles overlap.

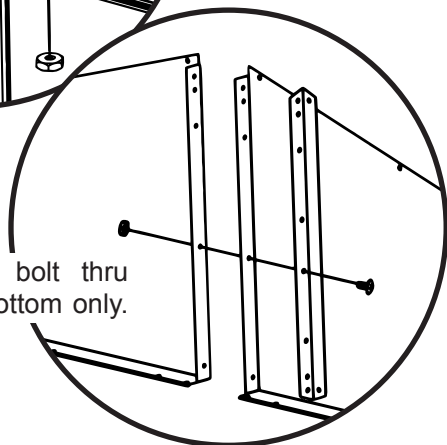

Attach Brace with bolt thru second hole from bottom only.

Step 11: Continued

You will need for this page:

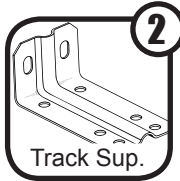
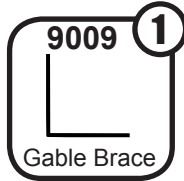
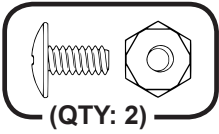

5 Working with one **Gable** at a time, attach the front **Gables** to the **Door Track** with screws. Do not insert screws into the two (2) holes closest to the peak of each **Gable**. These will be used to attach the **Track Support** later.

6 To secure **Gables** together, position the **Gable Brace** as shown and insert a single bolt and nut through the second hole from the bottom only.

7 Position **Track Support** as shown. Secure **Track Supports** to **Gable** using one (1) bolt and nut. Secure to **Door Track** using two (2) screws per side.

Leave two (2) holes open on each side of the Gable peak to attach Track Support.

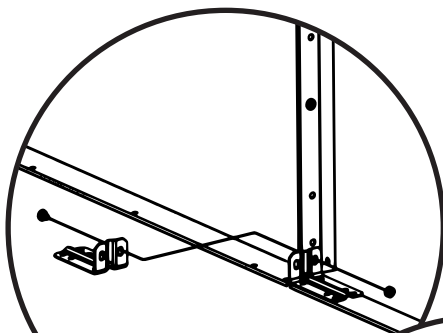
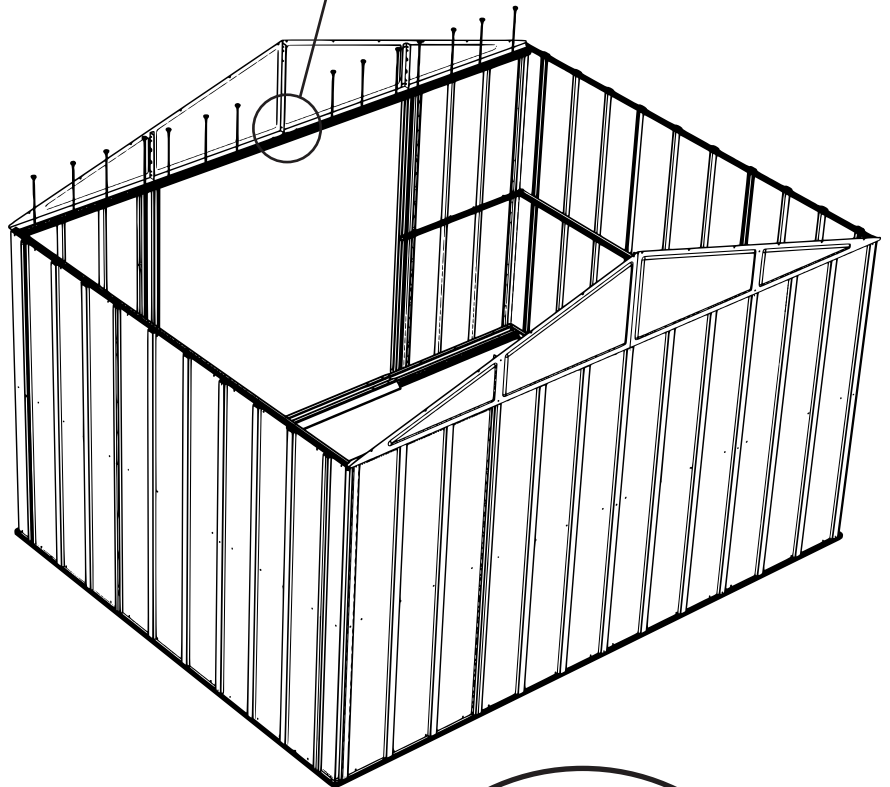

Install Track Support.

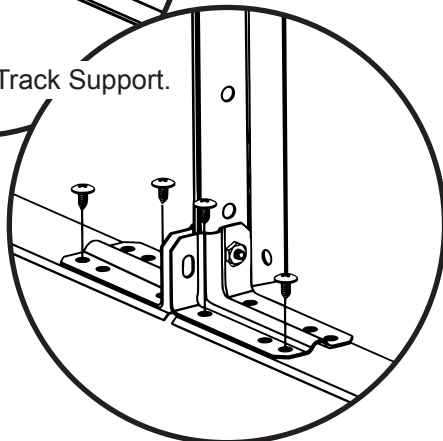

Attach Brace with bolt thru second hole from bottom only.

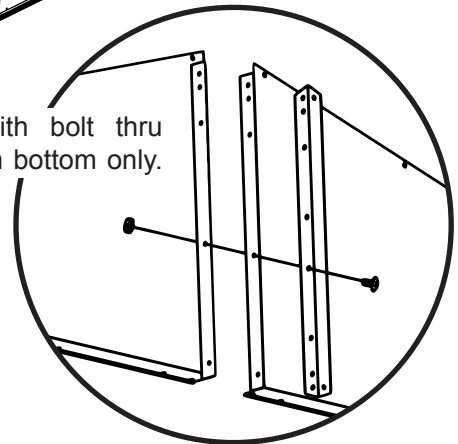

Step 12: Roof Framing

You will need for this page:

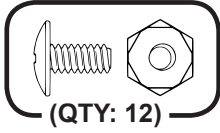

Assemblies from Step 3:

- Main Roof Beam Assembly (1)
- Single Roof Beam Assemblies (2)

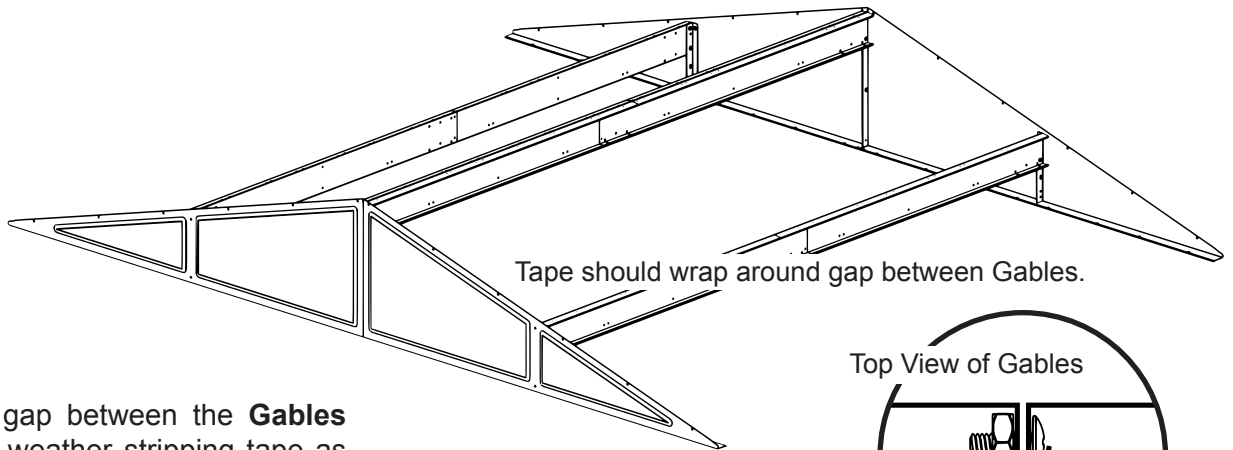

1 Seal the gap between the **Gables** using the weather stripping tape as shown. Do this at both ends of the building before installing **Roof Beams**.

Top View of Gables

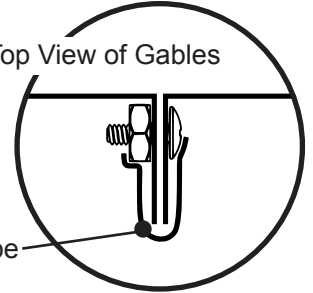

2 Position the **Roof Beams** as shown below and install using two (2) bolts and nuts per side. Install the **Main (center) Beam** first.

Tape BOTH Gable joints before installing Roof Beams.

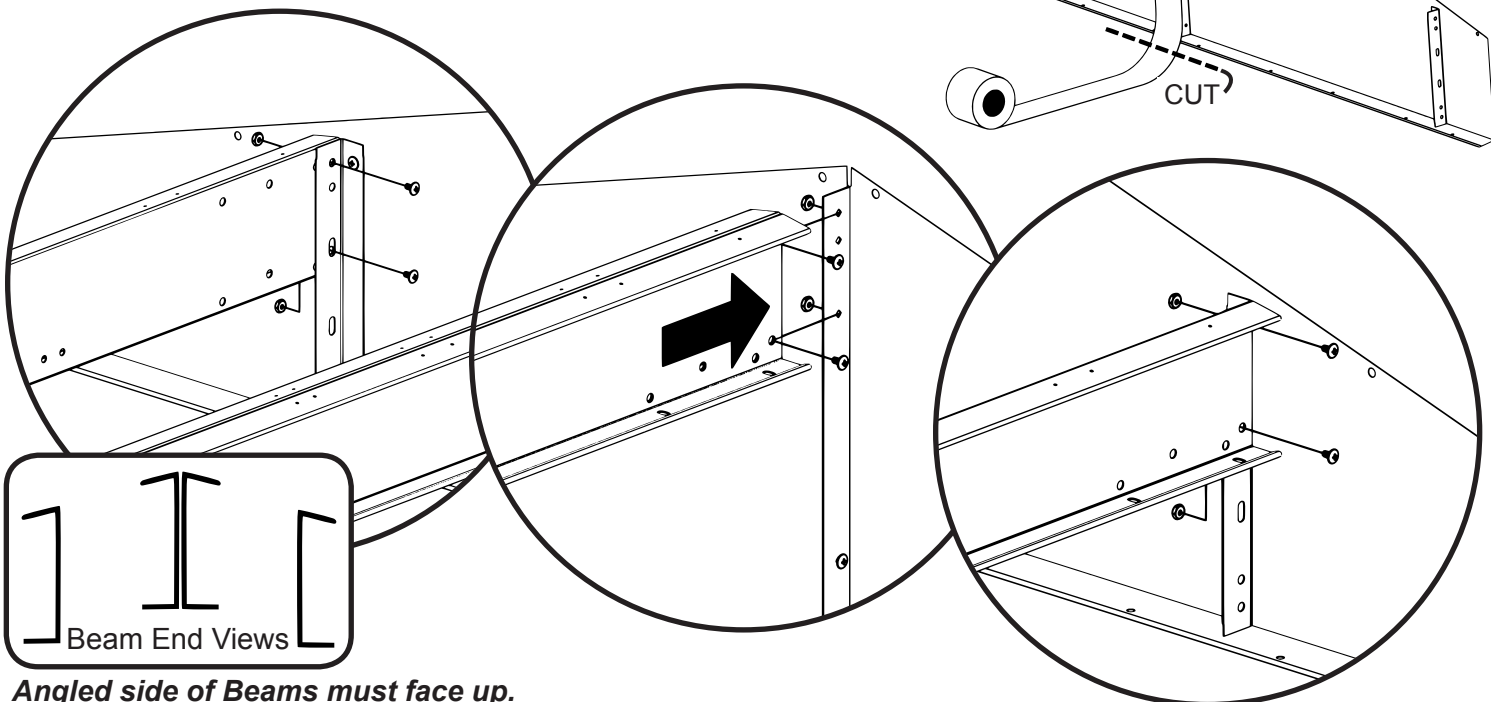
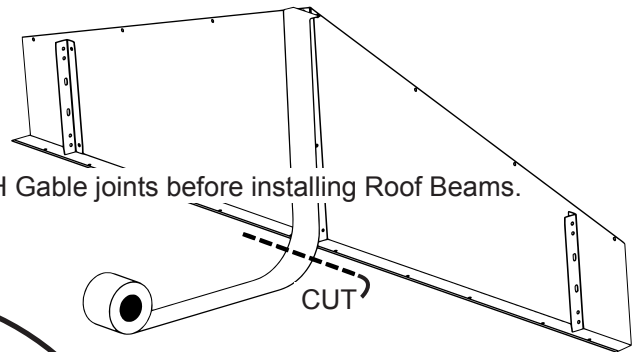

Step 12: Continued

You will need for this page:

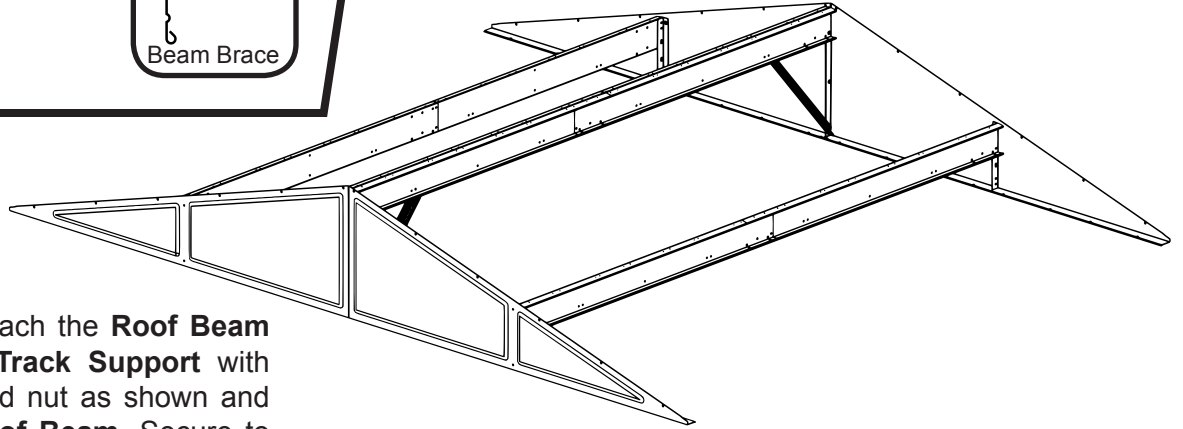
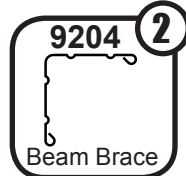
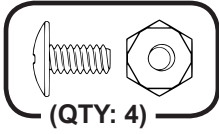

3 In the front, attach the **Roof Beam Brace** to the **Track Support** with one (1) bolt and nut as shown and rotate to align with **Roof Beam**. Secure to **Roof Beam** with one (1) bolt and nut as shown.

4 In the rear, attach the **Roof Beam Brace** to the **Gable** with one (1) bolt and nut as shown and rotate to align with **Roof Beam**. Secure to **Roof Beam** with one (1) bolt and nut as shown.

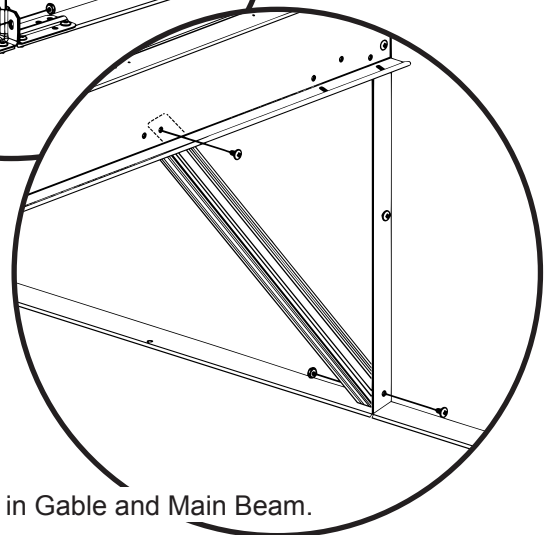
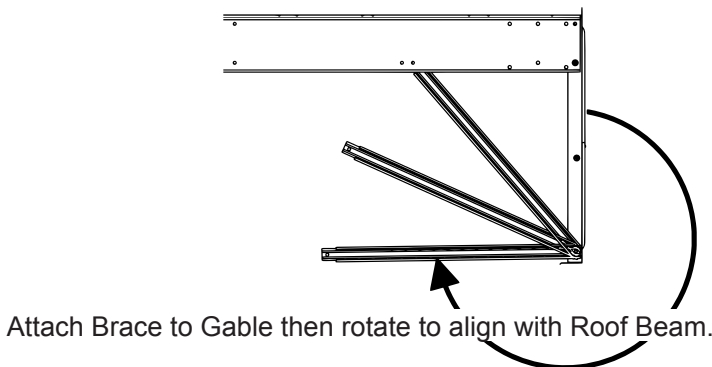
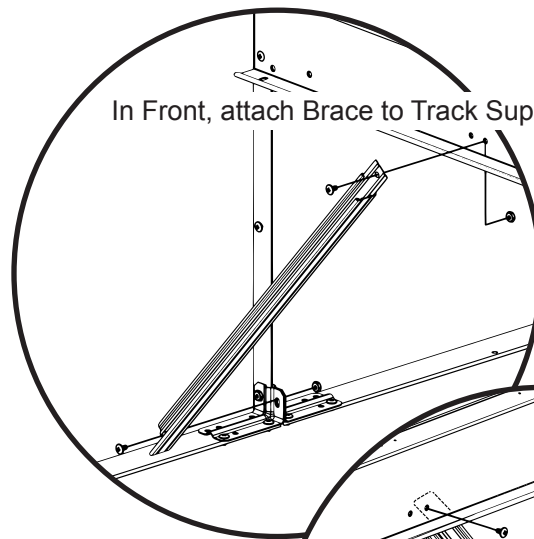
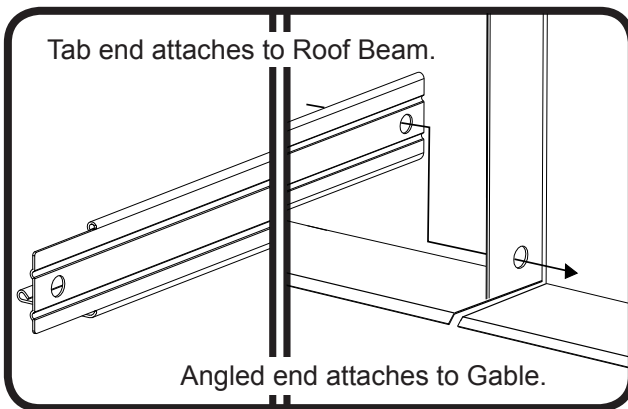

Roof Install Prep Page

Use the information on this page to complete steps 13 thru 15.

NOTE If Roof Beam holes do not line up with Roof Panel holes, shift the building from left to right. If this does not help, your building may not be level. Shim the corners until holes line up.

NOTE Measure the building diagonally again to make sure the building is square. The building should be square at the base and at the top. This will make roof panels fit better and holes will better align.

NOTE If a Roof Strengthening Kit was purchased, assemble and install before attaching Roof Panels.

NOTE Be sure to carefully follow the Roof Panel Placement Order Diagram on this page.

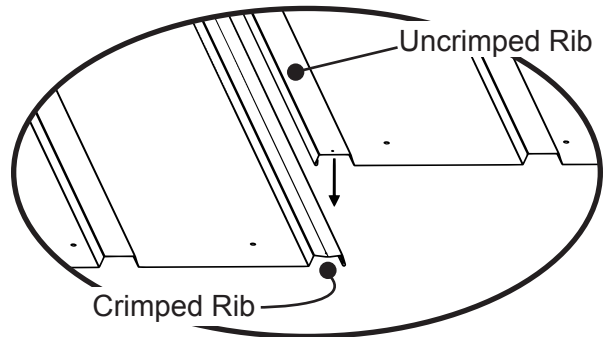
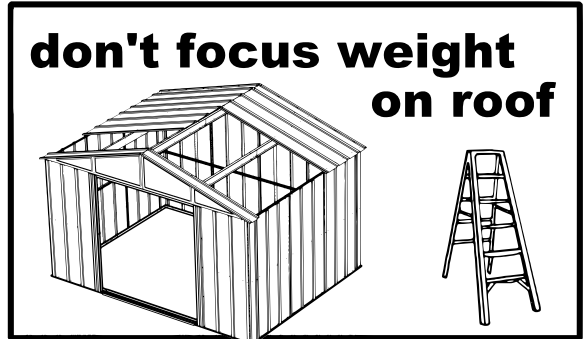

Whenever a crimped rib and an uncrimped rib meet, place the crimped rib UNDER the uncrimped rib.

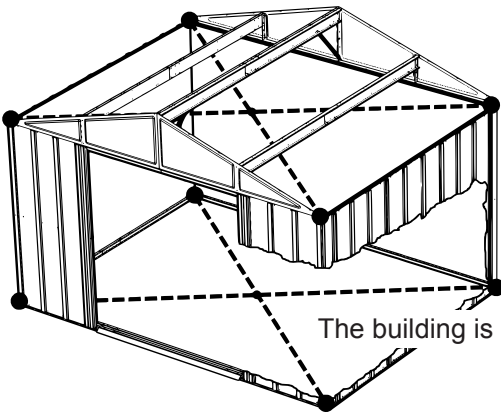

The building is square when diagonal measurements are equal.

Roof Panel Placement Order

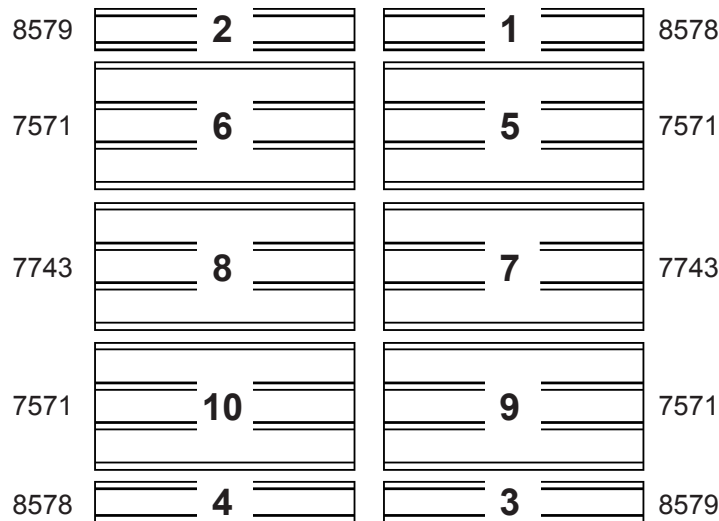

FRONT

Step 13: Roof Corners

You will need for this page:

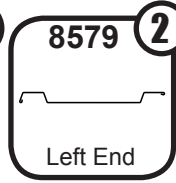
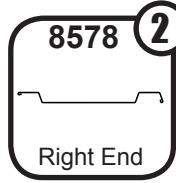
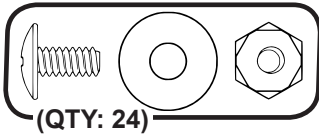
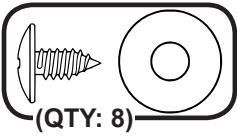

1 Secure the first **End Panel** to the **Main Roof Beam** by placing a screw in hole #1 (from the diagram below). Carefully remove the **Gable Edge Trim** once the **Panel** is in position.

2 Fasten **Panel** to **Gable** by placing bolts through holes #2 - #7. Fasten the holes in order.

3 Secure the **Panel** to the **Lower Roof Beam** by placing a screw in hole #8. Repeat for other three **End Panels**.

An Awl may be used to help align holes that are only slightly misaligned. Take care not to bend or warp the metal, and always practice proper tool safety.

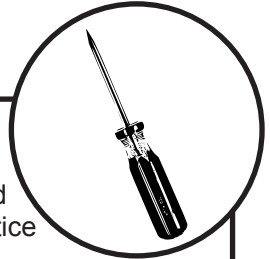

NOTE Work one corner at a time. Be sure to finish a corner before moving on to the next one.

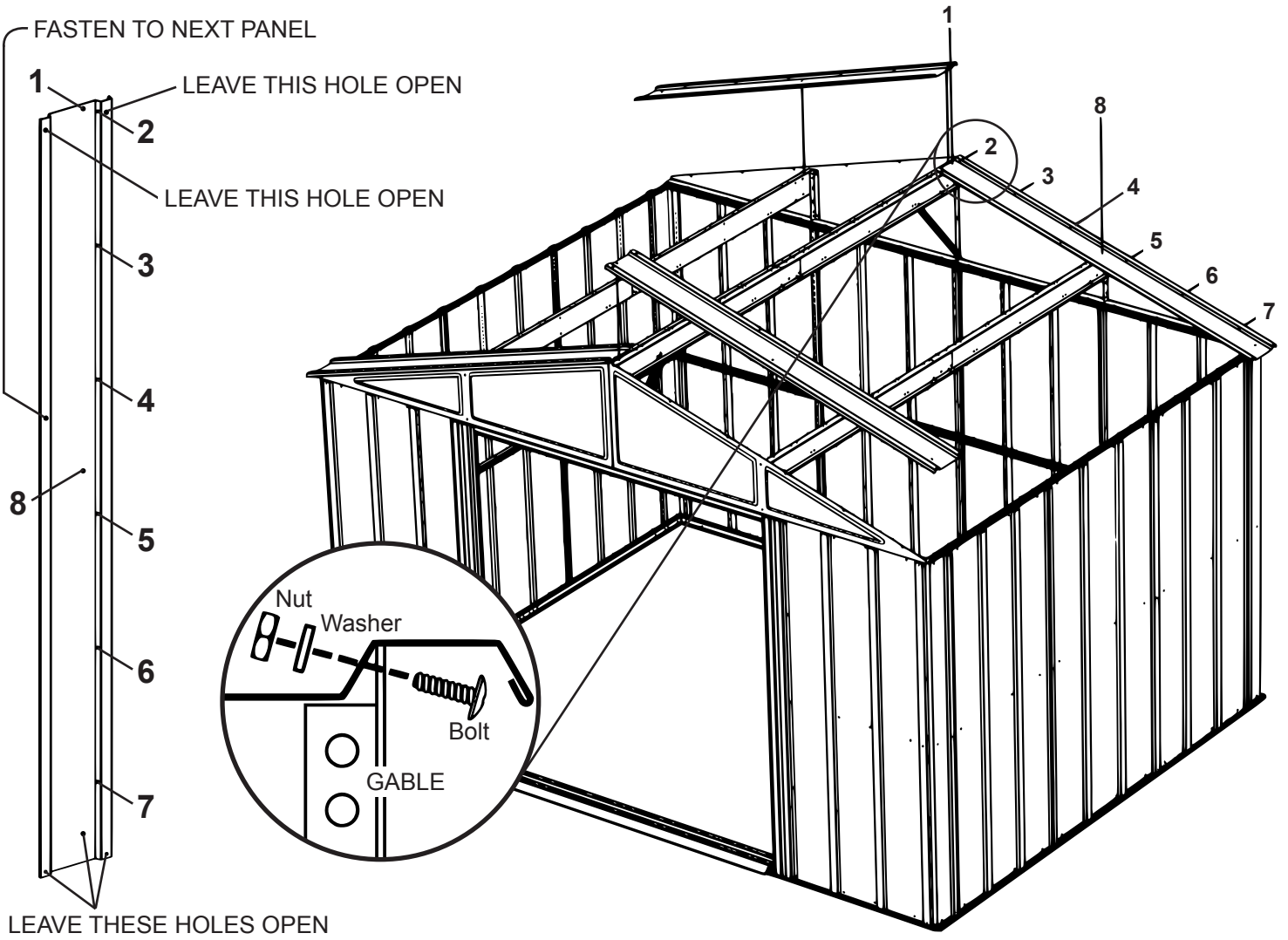

Step 14: Roof Assembly

You will need for this page:

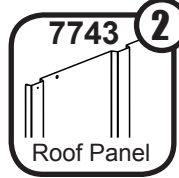
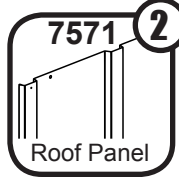
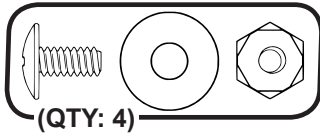
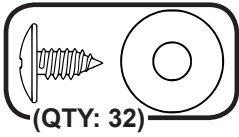

1 Cut four (4) strips of weather stripping 2" (5,1 cm) long from the roll of weather stripping tape and put aside for later use. Begin weather stripping the roof ridge. Apply more of the weather stripping after each additional **Panel** is installed.

2 Attach **Panels #5 - #8** in the order given in the diagram on page 34. Use the diagram to the left while assembling the roof.

3 Do not fasten the holes on the lower end of the **Panels**. Do not install **Panels #9 or #10** yet. Double check that **Panels** are installed in the correct position. The part numbers listed in the Roof Panel Placement diagram on page 34 must match the numbers inked on the **Panels**.

FASTEN TO RIDGE CAP (NEXT TWO PAGES)

FASTEN TO ROOF BEAMS WITH SCREWS

FASTEN TO NEXT PANEL WITH BOLT AND NUT

DO NOT FASTEN AT THIS TIME

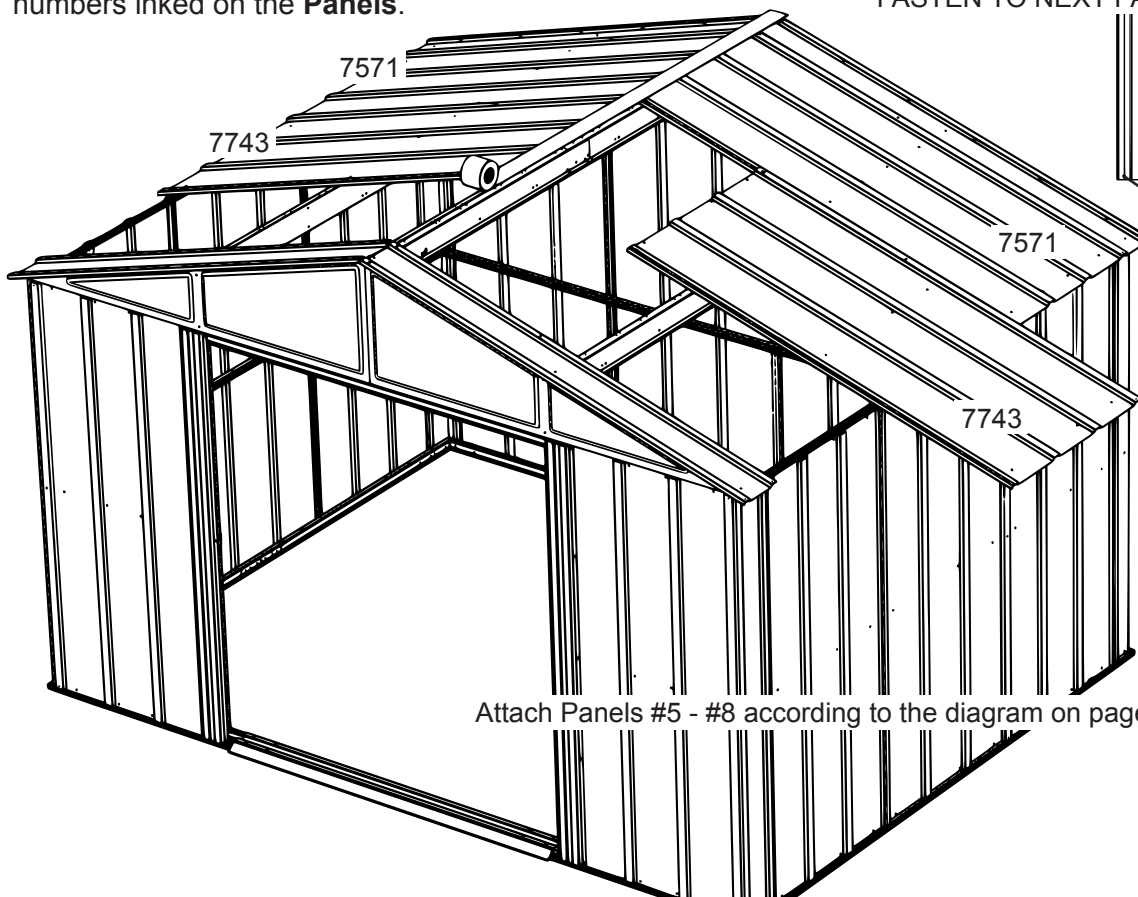

Attach Panels #5 - #8 according to the diagram on page 34.

NOTE Weather stripping tape should be applied in one continuous strip along the length of the roof.

Step 14: Continued

You will need for this page:

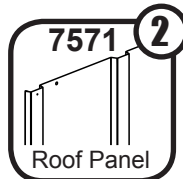
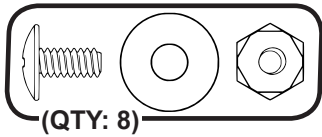
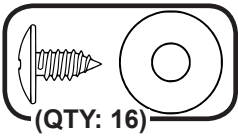

• Bolts under Ridge Cap pass thru slots where the End Roof Panel is overlapped by the Panel next to it (labeled rib 2 below).

Continue to apply weather stripping.

4 Attach **End Panels** to the **Roof Panel** next to it using one (1) bolt and nut each. Place a strip of tape over the bolt to seal.

5 Attach **Long Ridge Cap** with two (2) bolts and nuts. **DO NOT** secure end of **Ridge Caps** until **Peak Caps** are in place.

6 Install **Roof Panels** #9 and #10.

• Bolts thru Ridge Cap pass thru slots where the Center Roof Panel overlaps the Panel next to it (labeled rib 5 below).

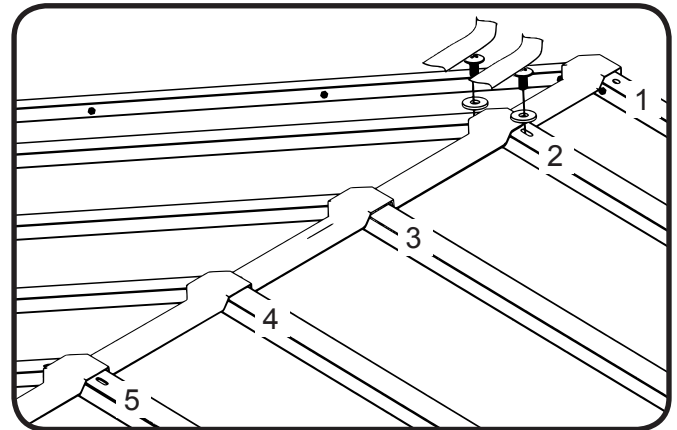

NOTE DO NOT fully tighten Ridge Cap bolts until you have both Ridge Cap bolts in place. This will ease assembly. Bolts must be fully tightened before moving on to the next page.

DO NOT secure end of Ridge Caps until Peak Caps are in place.

Place strips of tape over bolts to seal.

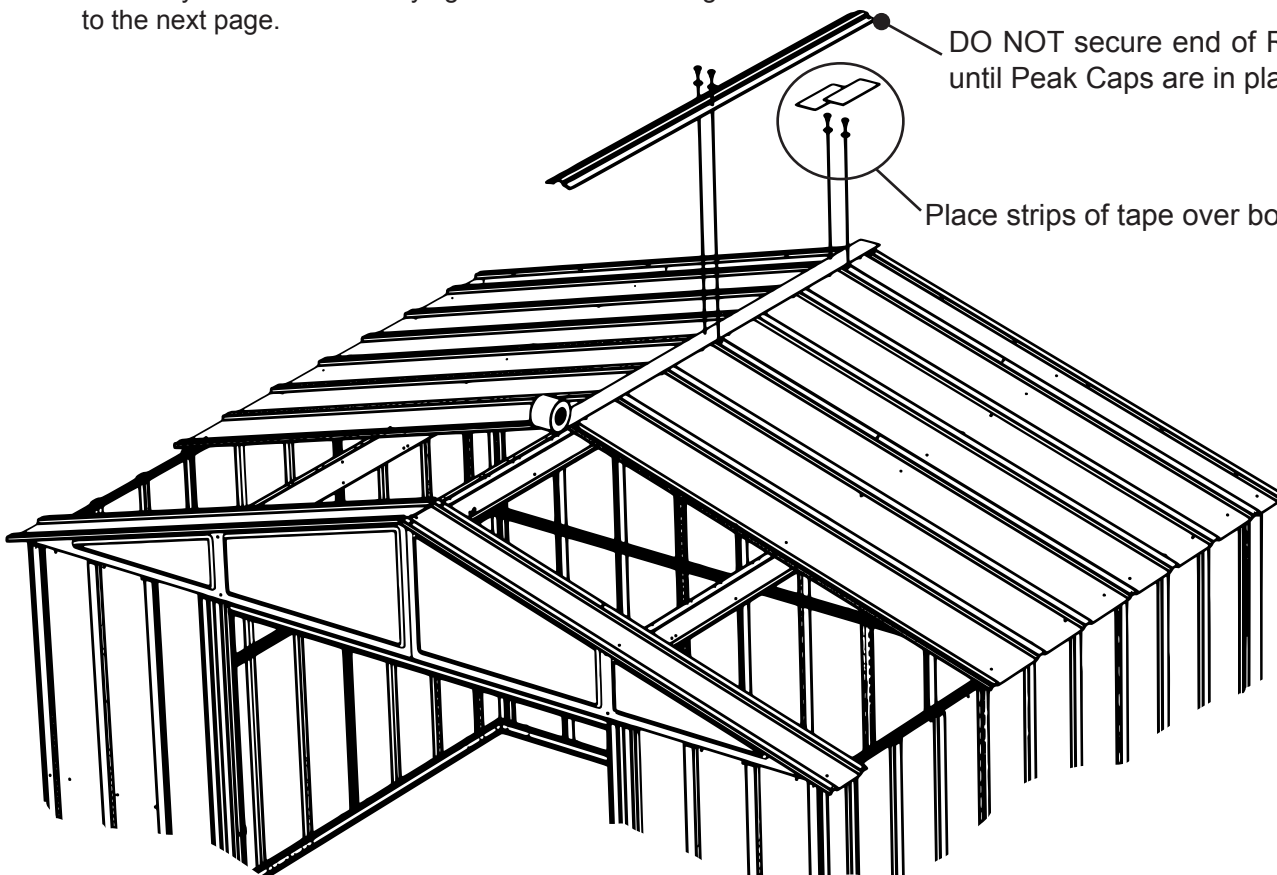

Step 14: Continued

You will need for this page:

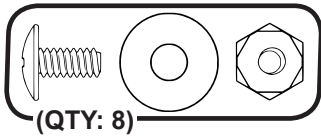
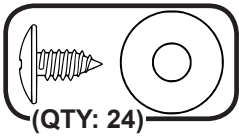

Continue to apply weather stripping.

- 7** Finish weather stripping the roof and cut the tape just past the end of the roof. Fold end of tape under roof edge.
- 8** Attach **End Panels** to the **Roof Panel** next to it using one (1) bolt and nut each. Place a strip of tape over the bolt to seal.
- 9** Attach **Short Ridge Cap** with two (2) bolts and nuts. **DO NOT** secure end of **Ridge Caps** until **Peak Caps** are in place.
- 10** On both sides of the building, secure the bottom of **Roof Panels** to the **Side Wall Angles** with screws. Use bolts and nuts where **Wall Angles** overlap.

DO NOT secure end of Ridge Caps until Peak Caps are in place.

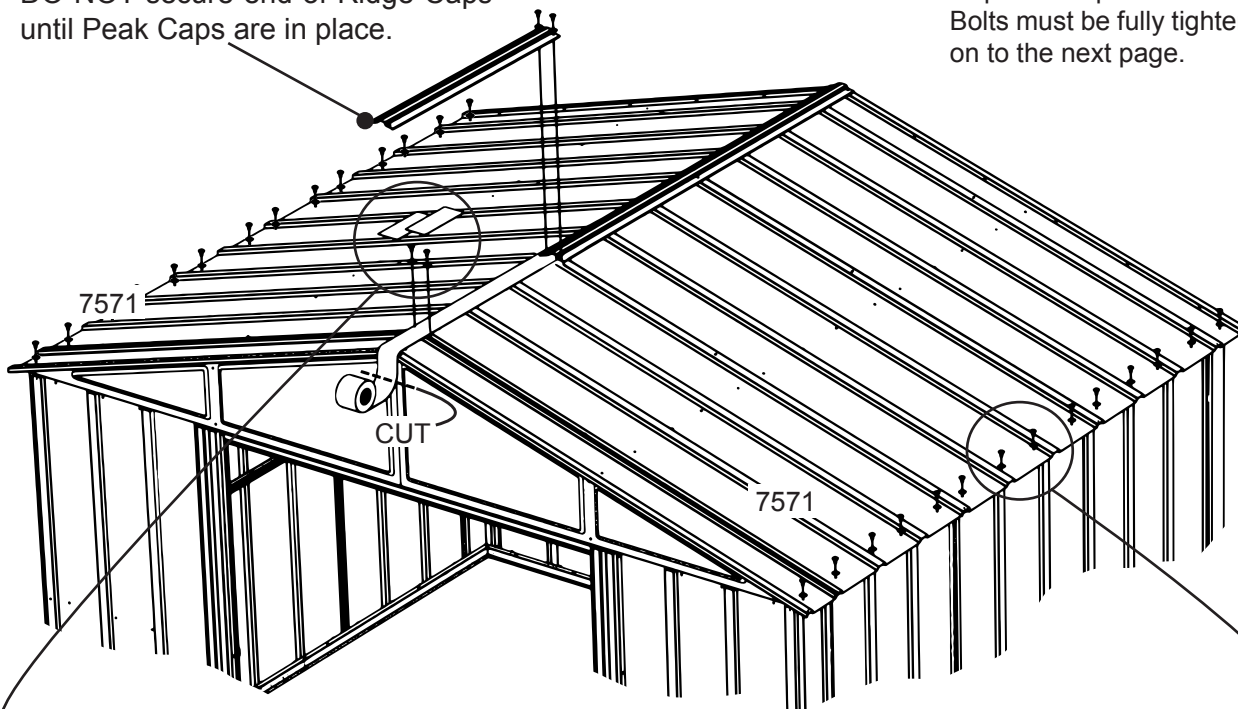

Place strips of tape over bolts to seal.

Use bolts where Wall Angles overlap.

- Bolts under Ridge Cap pass thru slots where the End Roof Panel is overlapped by the Panel next to it (labeled rib 2 below).

- Bolts that connect Ridge Caps together pass thru slots where the Center Roof Panel overlaps the Panel next to it (labeled rib 5 below).

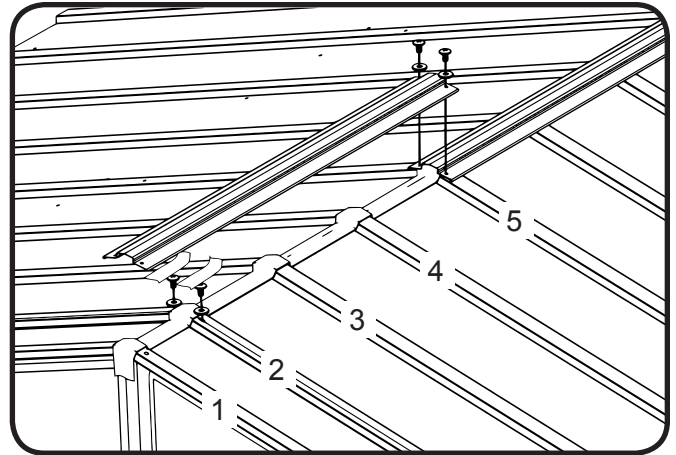

NOTE DO NOT fully tighten Ridge Cap bolts until you have both Ridge Cap bolts in place. This will ease assembly. Bolts must be fully tightened before moving on to the next page.

Step 15: Roof Trim

You will need for this page:

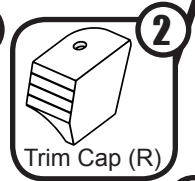
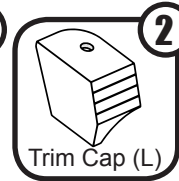
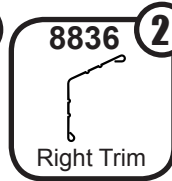
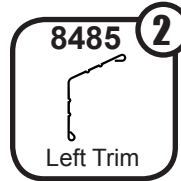
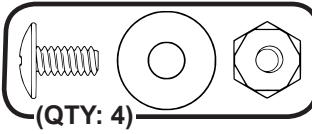
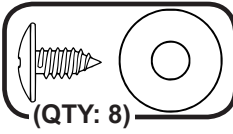

- 1 Slide **Peak Cap** legs under **Ridge Cap** and secure with two (2) bolts and nuts on each end.
- 2 Position **Roof Trim** as shown below and secure with screws. Do not fasten the last screw on each end. Pay close attention to where the **Left** and **Right Roof Trim** pieces are located.
- 3 Position the **Roof Trim Caps** as shown below and secure with a screw.

Roof Trim Caps are positioned as shown.

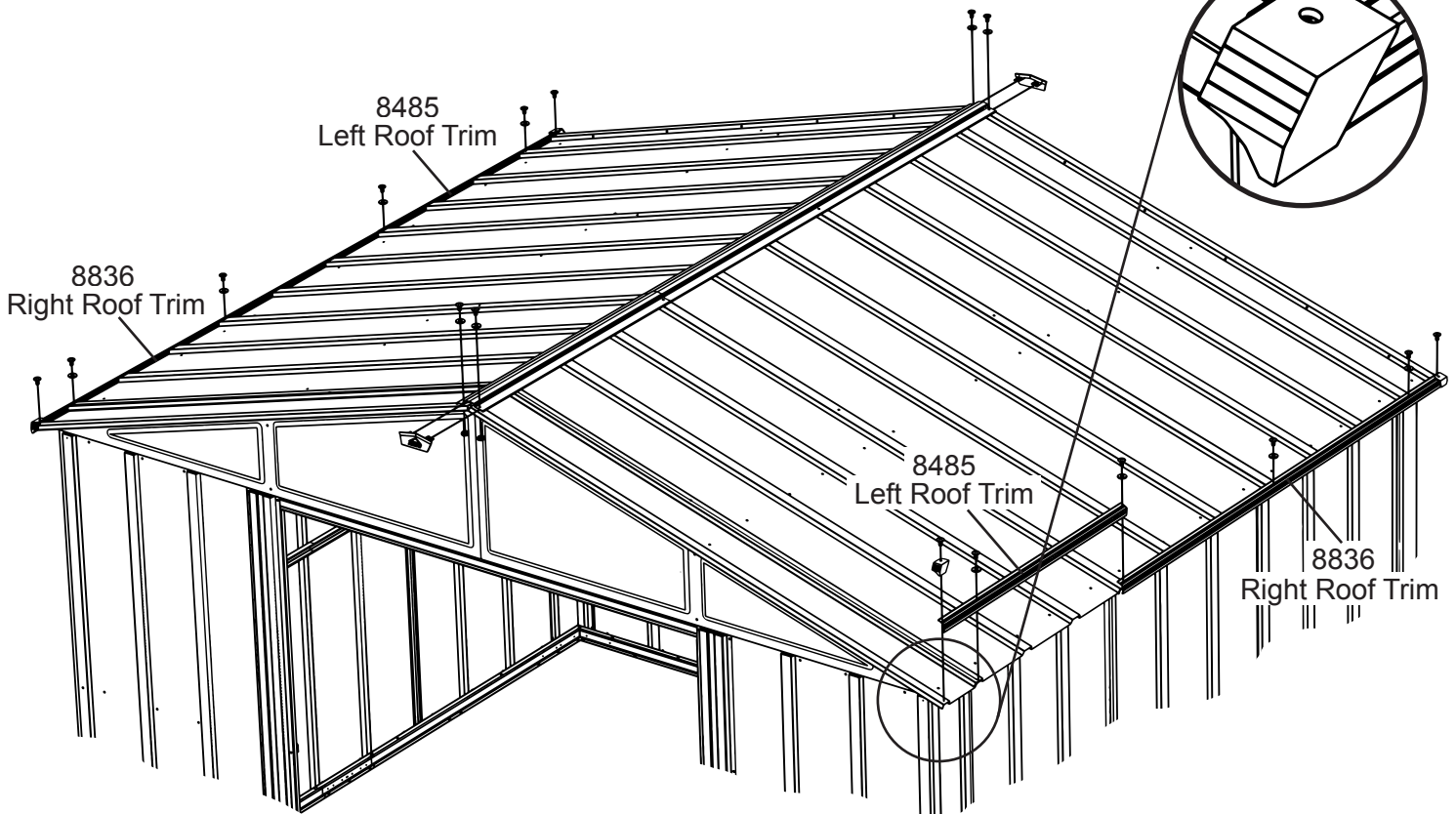

Step 16: Door Assembly

You will need for this page:

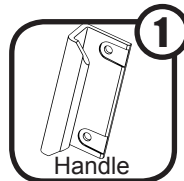
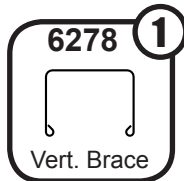
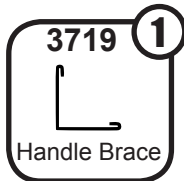
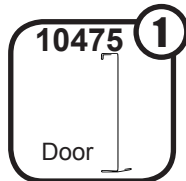
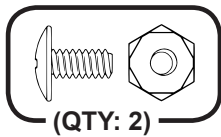
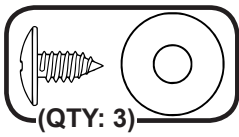

1 Attach the **Door Handle** and **Door Handle Brace** to the **Door** with two (2) bolts and nuts as shown. Do not fully tighten the bolts that hold in the **Door Handle** until the **Vertical Door Brace** is in place.

2 Rotate the **Door Handle Brace** to align it with the **Vertical Door Brace** as shown. Secure the **Vertical Door Brace** with three (3) screws. Tighten the **Door Handle** bolts.

NOTE Do not fully tighten the bolts that hold on the Door Handle until the Vertical Door Brace is in place.

Secure Door Handle and Handle Brace to Door with two (2) bolts and nuts.

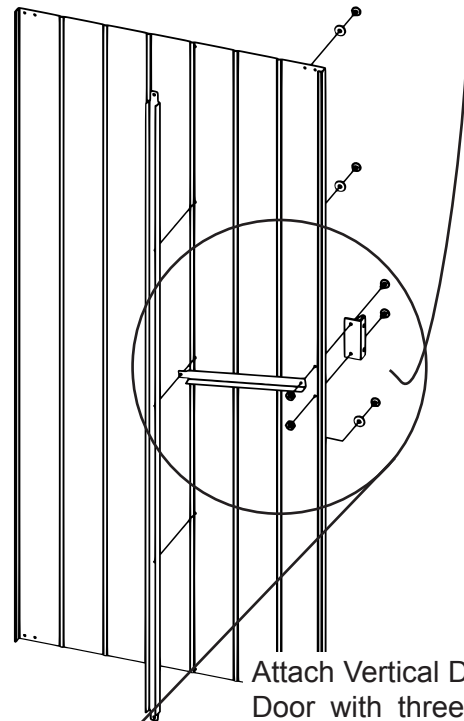
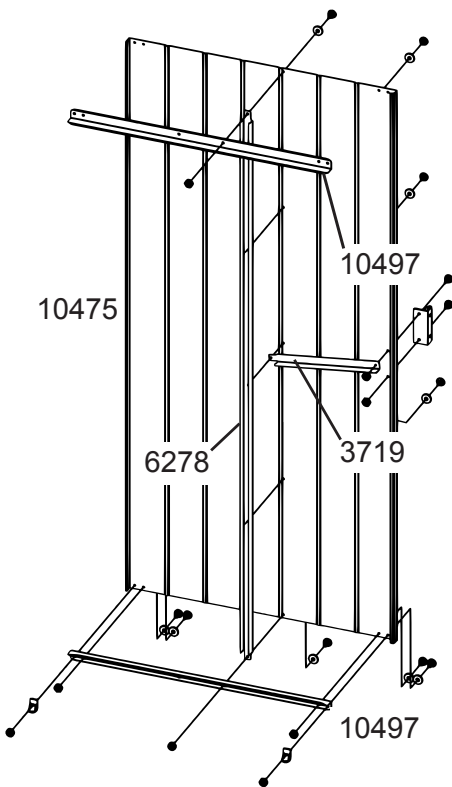

Attach Vertical Door Brace to Door with three (3) screws.

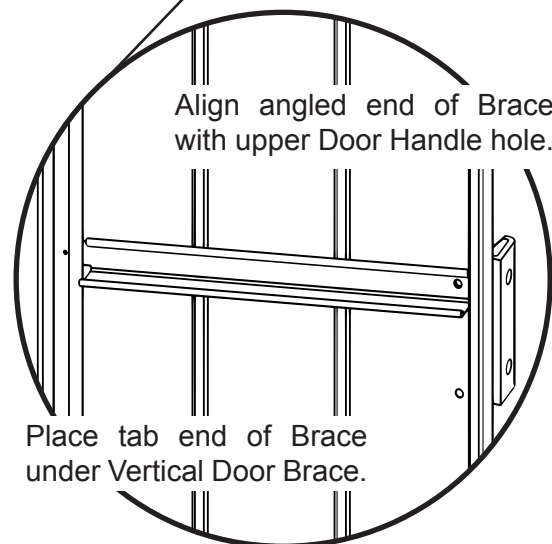

Align angled end of Brace with upper Door Handle hole.

Place tab end of Brace under Vertical Door Brace.

Install the Door Braces on the interior (gray) side of the Door.

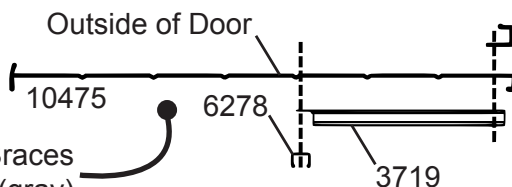

Step 16: Continued

You will need for this page:

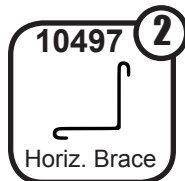
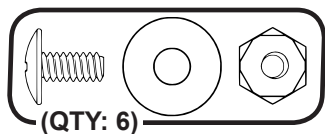

3 Slide **Horizontal Brace** over **Door** edge and secure with one (1) bolt and nut in top and bottom.

4 Secure the **Door Guides** and **Lower Horizontal Door Brace** as shown below. Repeat steps for second **Door**.

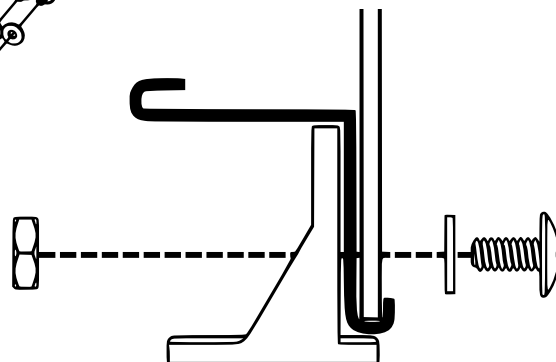
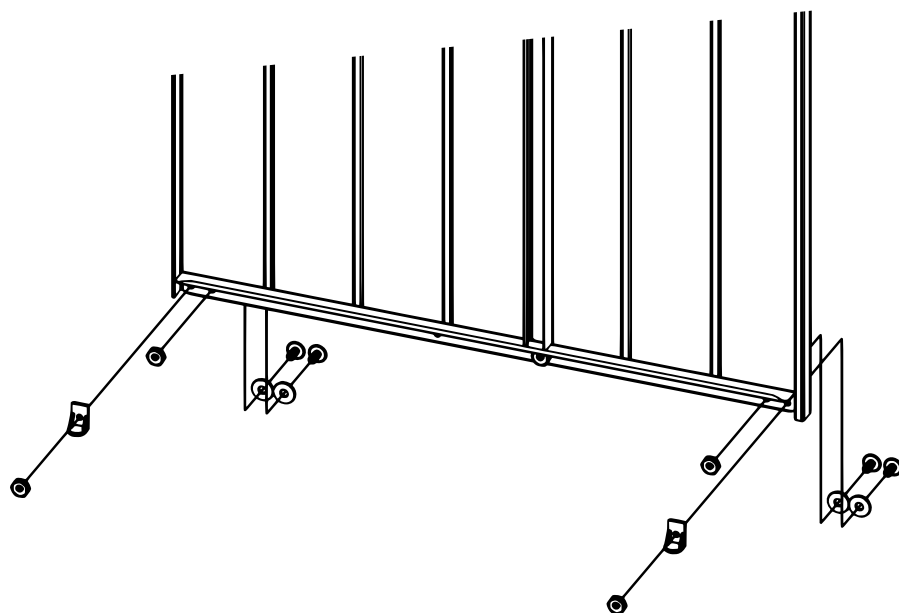
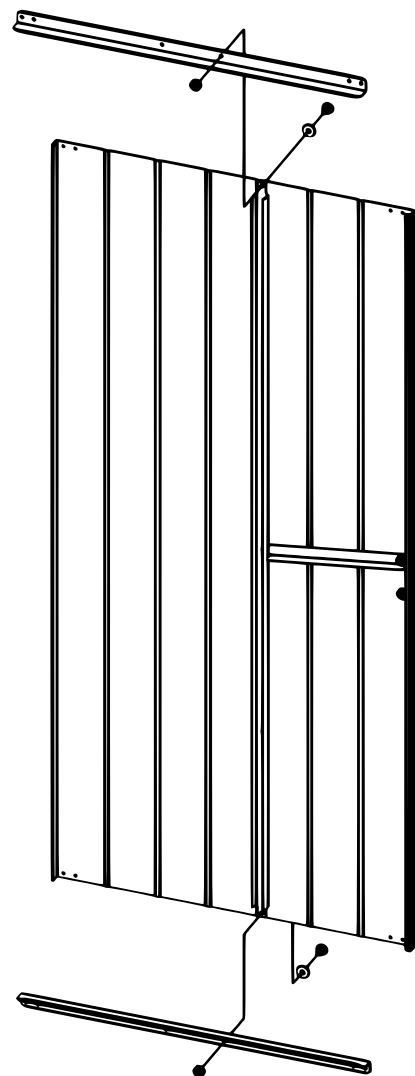

Repeat these steps for the other door.

Step 17: Door Install

You will need for this page:

Assemblies from Step 16:

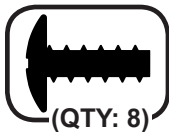

(QTY: 8)

- Right Door Assembly (1)
- Left Door Assembly (1)

- 1 From inside the building, place the bottom of the **Door** into the **Front Floor Frame** track at about the half-open position.
- 2 Rotate the **Door** forward until it is vertical and align the **Door Slides** with the **Door**.
- 3 Insert two (2) Black Screws into each **Door Slide** as shown below. Repeat steps for second door.

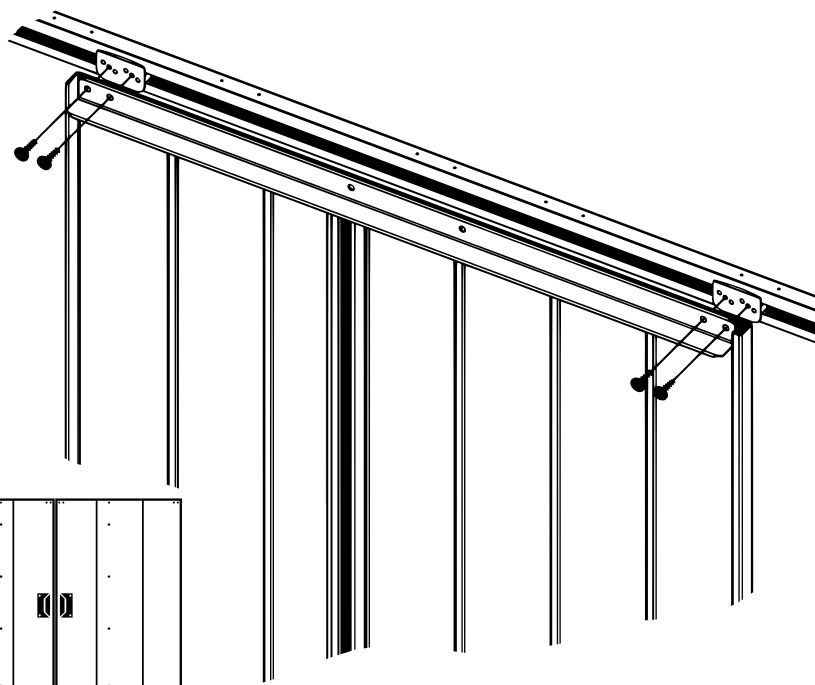
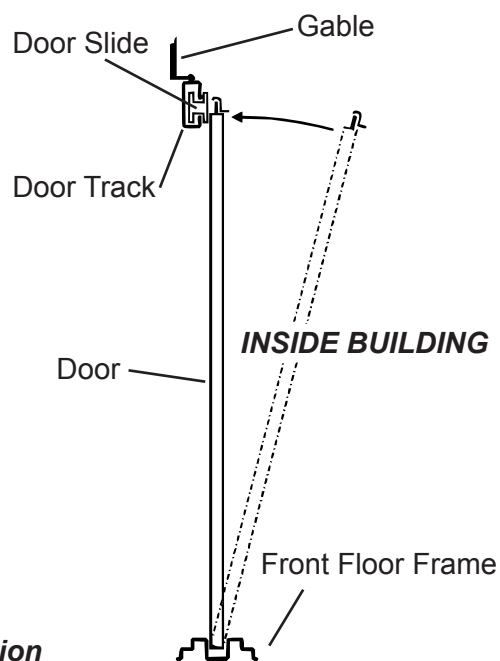
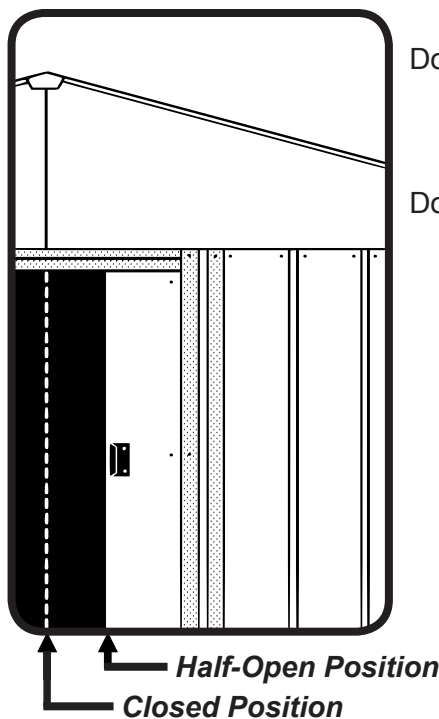

Door Adjustment

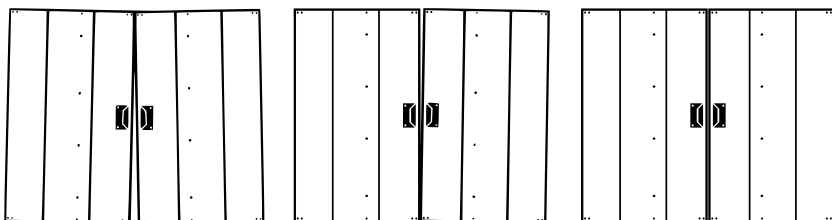

If Doors do not align, raise or lower one side of the Door by placing the Door screws through a different set of holes in the Door Slide.

ANCHORING OPTIONS...

IMPORTANT:

- *If you have swing doors, they must hang and swing level before anchoring building.*
- *Anchor your building at this time. See below for details on anchoring.*
- *If you have purchased a Floor Frame Kit, you should install it at this time.*
- *Please take a moment to ensure that the building is installed in accordance with these instructions and with all applicable regulations.*

Anchoring Down The Building

The entire floor frame **MUST** be securely anchored once the building is erected.

Below are recommended ways of anchoring.

Arrow Anchoring Kit: (Model No. AK4 or 60298)

Recommended for use with **any** suggested **base**.

Contains: 4 Anchors with Cable, Clamps and installation instructions.

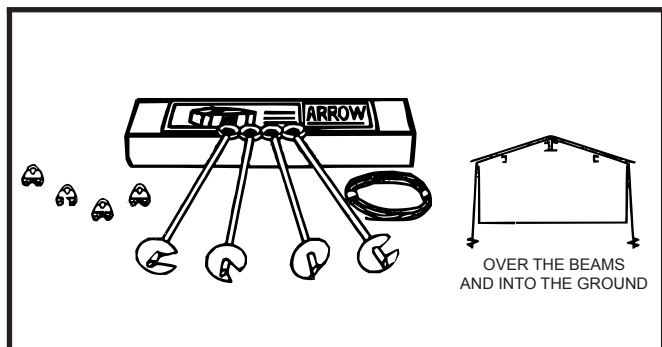

Arrow Anchoring Kit: (Model No. AK100 or 68383)

Recommended for use with the **concrete** base.

Contains: Corner gussets, perimeter clips, hardware, 1/4" masonry drill bit and installation instructions.

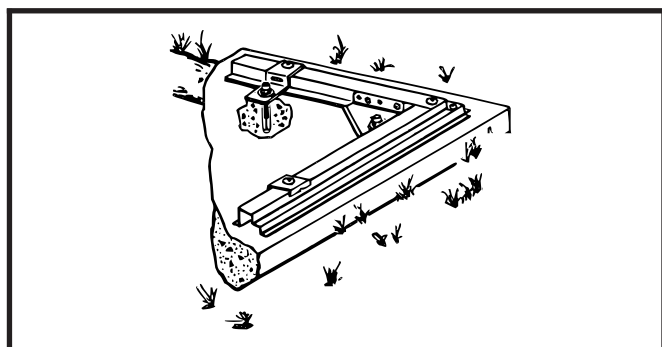

Anchoring into Wood/Post:

Use 1/4" (6 mm) Wood Screws. There are 1/4" (6 mm) dia. holes provided in the frames for proper anchoring.

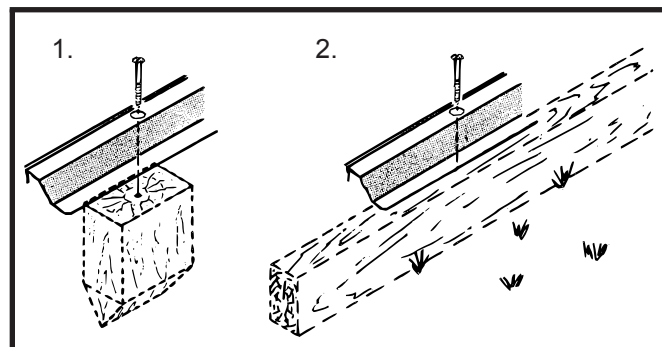

Anchoring into Concrete:

1. For poured concrete slab or footing or patio blocks: Use 1/4" x 2" (6 mm x 51 mm) Lag Screws.
2. For Anchor Post of Concrete poured after building is erected: Use 1/4" x 6" (6 mm x 152 mm) Lag Screws.

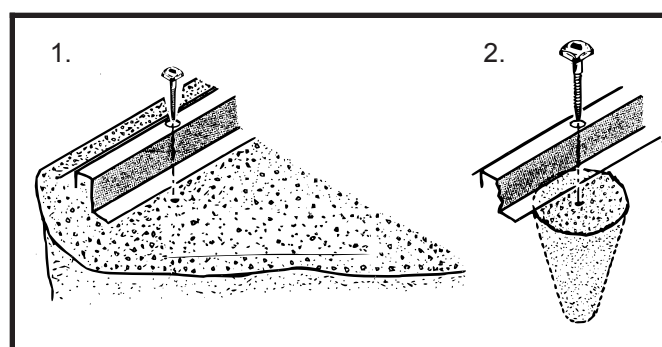

An Anchor Kit may be purchased online at www.arrowsheds.com
You can also purchase one over the phone by calling 1-800-851-1085.
See accessories page for details.

CARE & MAINTENANCE...

Exterior Care:

For a long lasting finish, clean and wax the exterior surface. We recommend washing with a mild soap solution. DO NOT use power washing to clean your shed. Using a spray automotive type wax periodically on the exterior is highly recommended if you are in a high humidity or coastal climate region.

Combustibles and corrosives must be stored in air tight containers designed for chemical and/or combustible storage. Corrosive chemicals such as fertilizers, pesticides and herbicides should be cleaned off the interior and exterior surfaces immediately. Rust caused by chemical damage is not covered by the warranty.

DO NOT STORE POOL CHEMICALS IN YOUR SHED - THIS VOIDS YOUR WARRANTY

Rust protection precautions may help to stop rust from developing, or stop it quickly as soon as it appears.

- Avoid nicking or scraping the coating surface, inside and out.
- Keep roof, base perimeter and door tracks free of debris and leaves which may accumulate and retain moisture. These can do double damage since they give off acid as they decay.
- Touch up scrapes or nicks and any area of visible rust as soon as possible. Make sure the surface is free of moisture, oils, dirt or grime and then apply an even film of high quality touch-up paint.
- Various paint manufacturers provide products for rust treatment and coverage. If surface rust does appear on your shed we recommend treating those areas as soon as possible, following the paint supplier of your choice instructions.
- Our customer service department can provide the paint tinting formula for matching the color of your shed. We also have touch-up paint available for repairing small nicks and scratches.

Roof:

Keep the roof clear of leaves and snow. Heavy amounts of snow on the roof can damage the building making it unsafe to enter. In snow country, Roof Strengthening Kits are available for most Arrow Buildings for added protection against heavy snow accumulation.

Doors:

For sliding doors, always keep door tracks clear of dirt and other debris that prevents them from sliding easily. Lubricate door track annually with furniture polish or silicone spray. Keep doors closed and locked to prevent wind damage.

Fasteners:

Use all washers supplied to protect against weather infiltration and to protect the metal from being scratched by the screws. Regularly check screws, bolts, nuts, etc., and retighten as necessary.

General:

- A plastic sheet (vapor barrier) placed under the entire floor area may reduce condensation.
- Wash off inked part numbers on coated panels with soap and water.
- Silicone caulking may be used for watertight seals throughout the building.

Please note, Manufacturer cannot be held responsible for any consequences due to buildings that are not installed per these instructions, or for damage due to weather conditions or acts of God.

Keep these assembly instructions and owner's manual for future reference.

ARROW ACCESSORIES...

ROOF STRENGTHENING (heavy snow load) KITS

Extra roof beams and gable braces designed for added protection against heavy snow accumulation. Increases the strength of your roof.

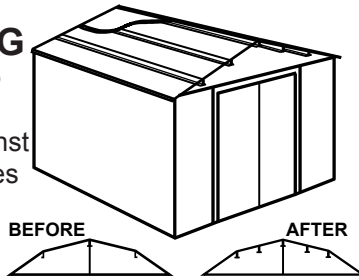

FLOOR FRAME KITS

MODELS FB47410, FB5465, FB106-A, FB109-A and FB1014-A

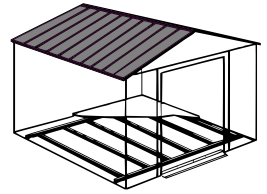

A simple floor frame system made of heavy-duty, hot-dipped galvanized steel. Use as base for plywood, sand or stone.

ANCHOR KITS

Model No. AK4

Anchor Kit contains heavy-duty steel augers, 60' (18 m) of steel cable and 4 cable clamps. No digging or concrete pouring, just insert cable under roof, over roof beams, into augers and twist augers into the ground. For buildings larger than 10'x9' (3,0 m x 2,6 m), use 2 kits.

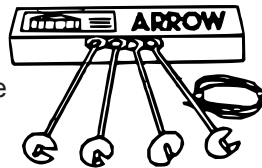

ATTIC KIT / WORKBENCH KIT

Model No. AT101

Heavy-duty galvanized steel bars that fit all 10' (3,0 m) wide Arrow buildings. They install quickly and easily to help organize space and create more useable space as an attic or workbench. Will hold up to 250 lbs. (113 kg) evenly distributed.

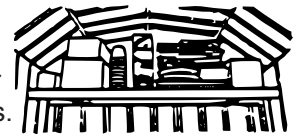

Some drilling required to fit buildings without mid-wall bracing.

Model No. AK100

New concrete anchor system permits anchoring any size Arrow building directly to a concrete slab. Each kit contains heavy-duty, hot-dipped galvanized steel corner gussets and perimeter clips which fit over the floor frame and lag bolt into a concrete slab. Full assembly instructions and a 1/4" masonry drill bit are included.

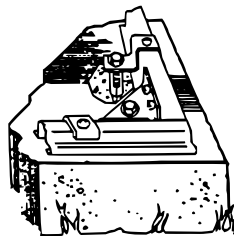

SHELF UNITS

Heavy-duty, galvanized steel shelf units help organize storage space. They easily mount on the wall or sit on the floor. Fits all Arrow buildings.*

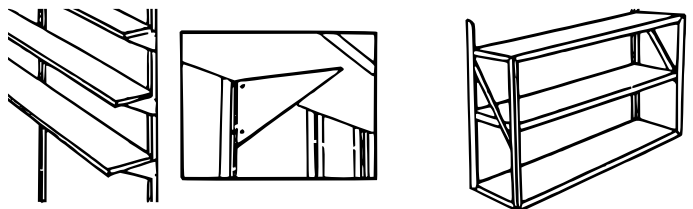

Model No. AK600

Earth Anchor Kit anchors any size Arrow building to the ground. Each kit contains heavy duty, hot-dipped galvanized steel corner gussets and 4 earth anchors.

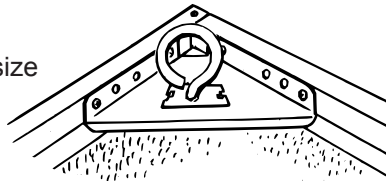

TOOL HANGING RACK

Model No. TH100

The perfect tool organizer. Twin 25 1/2" (64,8 cm) steel channels plus five heavy-duty snap-in hangers and a small tool holder for screwdrivers, pliers, etc. Holders slide along channel for fully adjustable spacing. Great for garage, basement, or the back of any door. Fits all Arrow storage buildings.

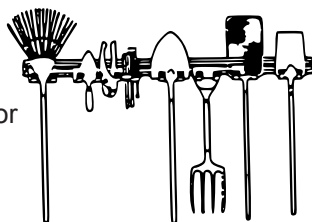

Model No. SS404

- Makes 8" to 12" (20,3-30,5 cm) wide shelves in any length.
- Brackets, braces, hardware included.
- Lumber is not included.

Model No. SS900-B

- Grey color
- 3 shelves
- Holds up to 85 lbs. (38 kg) (even weight distribution)

* Some drilling required to fit buildings without mid-wall bracing.

SPECIAL NOTICE ON DELIVERY:

If your accessory is shipped via truck line a day time phone number is required to arrange delivery. If no one is available to sign for the delivery, you may be subject to a re-delivery charge assessed by the carrier.

HOW TO ORDER

We recommend that you purchase accessory items from your local storage building dealer whenever possible; however, because the full line of accessories is not always available from all dealers, Arrow is offering them to you on a direct basis.

Purchase Online at www.arrowsheds.com

Purchase over the phone by calling 1-800-851-1085

Most major credit cards accepted. Allow 2 weeks for Delivery.

ASSEMBLY NOTES

ASSEMBLY NOTES

ASSEMBLY NOTES