

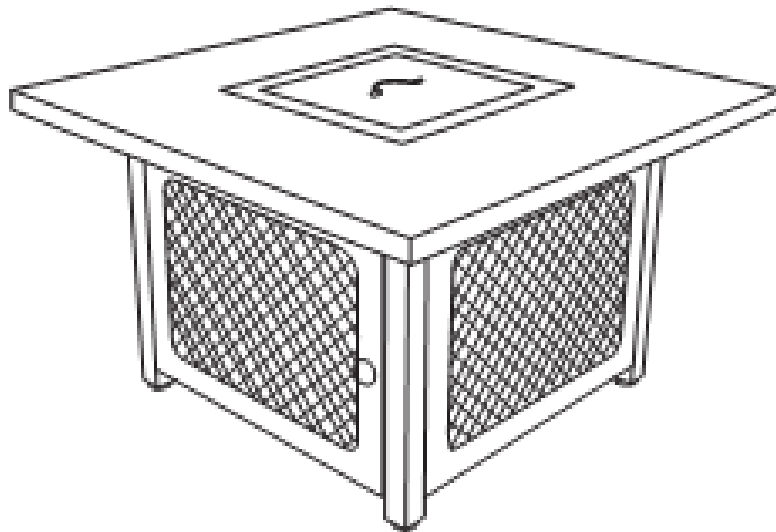

Assembly Instructions



PROPANE FIRE PIT













Questions, problems, or missing parts?
Before returning to the store, call Royal Garden Customer Service.

866-988-3300
8 a.m. -5 p.m., PST Monday - Friday

Retain this manual for future use.



Parts & Tools

PART	QTY	PICTURE & DESCRIPTION	PART	QTY	PICTURE & DESCRIPTION
A	1	 LID	J	1	 RIGHT DOOR LEG
B	1	 ROCKS (13.2LBS)	K	1	 PROPANE TANK SUPPORT
C	1	 TABLE TOP	L	20 + 1	 BOLT (M6X12MM)
D	2	 SIDE PANEL	M	20 + 1	 FLAT WASHER
E	1	 SIDE PANEL WITH OPENING			
F	1	 DOOR			
G	1	 LEFT DOOR LEG			
H	1	 LEFT LEG	<p>WARNING: To avoid damaging this product, assemble it on a soft, non-abrasive surface such as carpet or cardboard. Extremely heavy:use2 people for assembly</p>		
I	1	 RIGHT LEG			



Assembly

Step 1

- Place table top(C) upside down on a flat, protected surface.
- Attach left door leg (G),left leg (H),right leg (I),and right door leg (J) to table top(c) with bolts (L) and flat washers(M) using Phillips head screwdriver ,not included. Do not tighten completely.

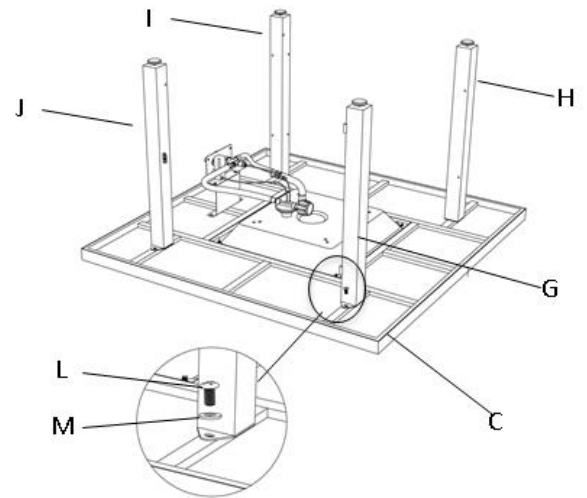

Step 2

- Attach side panel with opening(E) to right door leg (J) and right leg(I) with bolts (L) and flat washers(M) using Phillips head screwdriver, not included. Do not tighten completely.

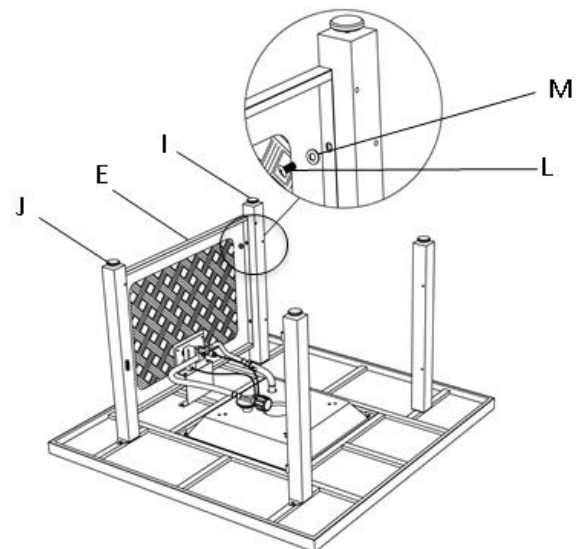

Step 3

- Attach side panel (D) to right leg (I) and left leg (H) with bolts (L) and flat washers (M) using Phillips head screwdriver, not included. Do not tighten completely.
- Attach second side panel (D) to left leg (H) and left door leg (G) with bolts (L) and flat washers (M) using Phillips head screwdriver, not included. Do not tighten completely.

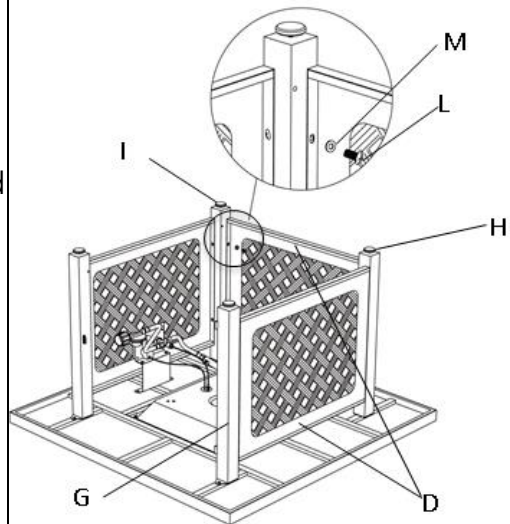

Step 4

- Position as shown. Attach propane tank support (K) to legs (G,H,I&J) with bolts(L) and flat washers(M) using Phillips head screwdriver, not included.
- Tighten completely all bolts from steps 1-4.

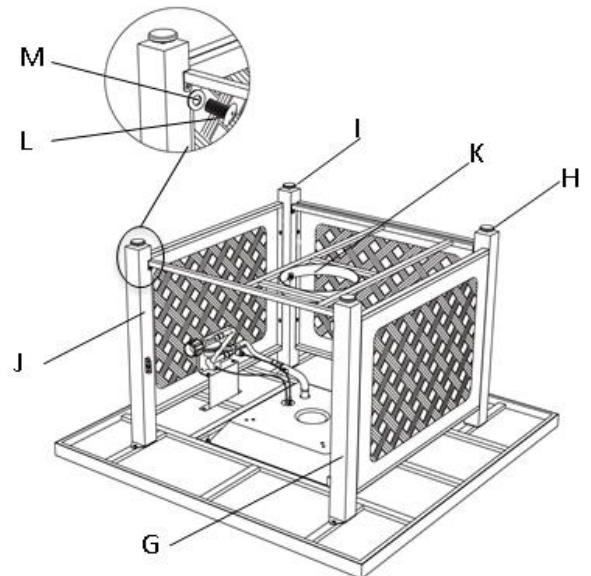

Step 5

- With 2 people, carefully rotate the assembled unit to the standing position.
- Slide the hinge of door (F) into left door leg (G)

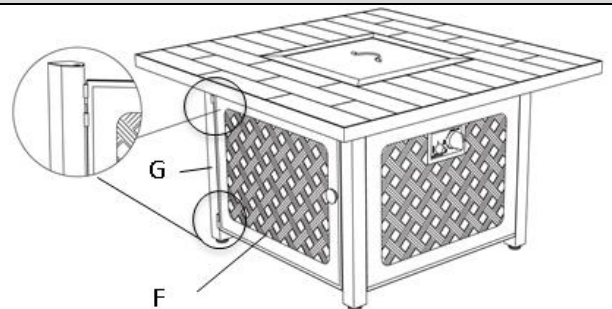

Step6

- Position assembled unit to desired location. Adjust levelers on bottom unit the table is stable.
- Place rocks (B) into the fire bowl. Ensure rocks are not covering the ignition portion of the burner.
- Place lid (A) over the top .The lid (A) must be removed when the burner is in operation. Wait until the unit cools completely before replacing lid (A).

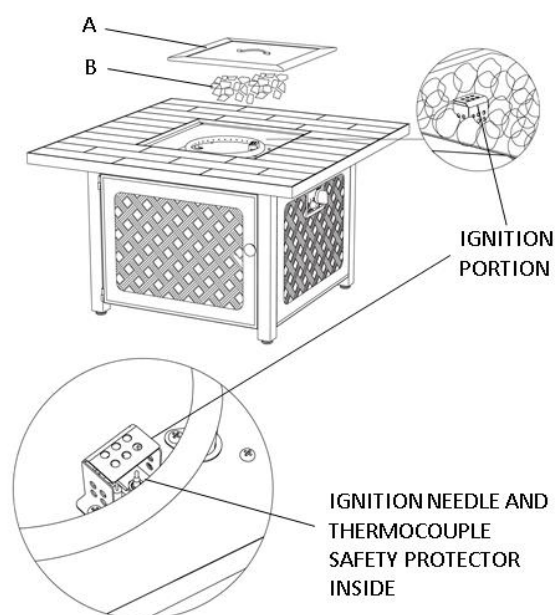

Step7:Attaching the metal sheet and the tube rim to the base tube

- Place the propane tank, not included, onto the propane tank support (K). Secure the tank by tightening the screw of the propane tank support (K).
- Connect the hose and regulator to the propane tank.

Note: Use a standard 20LB propane tank only.

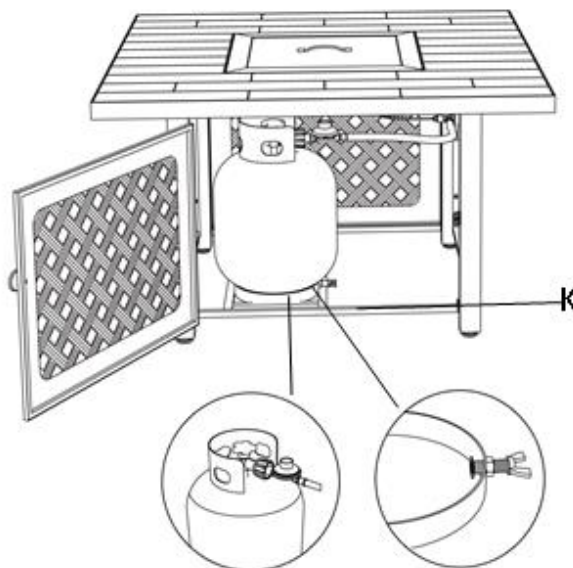

Step8:Inserting the Sunshade into the base tube

- Open the igniter cover and place the AAA battery, not included, into it. Then tighten the igniter cover completely.
- Assembly is complete.
- **WE RECOMMEND THAT YOU PERIODICALLY TIGHTEN ALL BOLTS.**

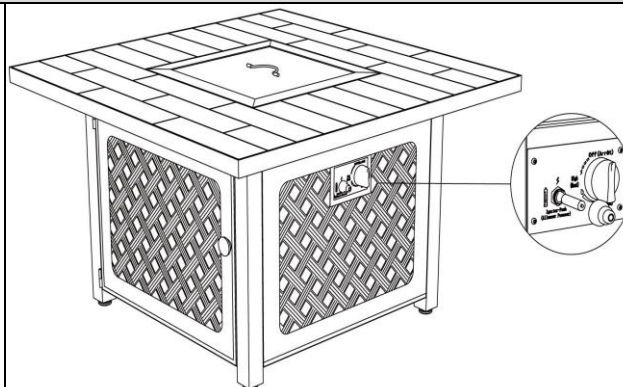



SAFETY INFORMATION

- **READ THE OPERATING INSTRUCTIONS BEFORE USE. THIS APPLIANCE MUST BE INSTALLED IN ACCORDANCE WITH SUCH REGULATIONS AS ARE ENFORCED.**

 **CAUTION:** Installer: Leave the manual with the user for future use. Consumer: Please keep this manual for future reference. Read the installation, operating, and maintenance instructions thoroughly before installing or servicing this gas appliance.

 **WARNING:** For outdoor use only

 **DANGER:** IF YOU SMELL GAS, Shut off gas to the appliance; Extinguish any open flame. If odor continues, keep away from the appliance and immediately call your gas supplier or fire department.

 **WARNING:** Do not try to light this appliance without reading the "LIGHTING" instructions section of this manual. Keep the appliance area clear and free from combustible materials, gasoline, and other flammable vapors and liquids. A propane tank not connected for use must not be stored in the vicinity of this or any other appliance.

 **DANGER: CARBON MONOXIDE HAZARD.** This appliance can produce carbon monoxide, which has no odor. Using it in an enclosed space can cause injury or death. This appliance should be used in a well-ventilated space and not in a building, garage or any other enclosed area.



 **WARNING:** Improper installation, adjustment, alteration, service, or maintenance can cause property damage, injury, or death.

CALIFORNIA PROPOSITION 65: Combustion by-products produced when using this product contain carbon monoxide, a chemical known to the State of California to cause birth defects (or other reproductive harm), and other chemicals known to cause cancer.

SAFETY INFORMATION (CONTINUED)



WARNING: Use a standard 20 lb propane cylinder only.

Reference the NFPA 58: Liquefied Petroleum Gas Code Manual for further guidance on Usage, Installation, Storage, etc.

Use this heater only with a propane vapor withdrawal supply system.

The pressure regulator and hose assembly supplied with the appliance must be used.

A dented, rusted, or damaged propane cylinder may be hazardous and should be checked by your cylinder supplier. Never use a propane cylinder with a damaged valve connection.

DO NOT USE LIQUID PROPANE OR SOLID FUEL.

DO NOT OBSTRUCT the combustion process or air ventilation flow.

OPERATING

LEAK TESTING OPERATION



WARNING: A leak test must be performed initially, annually, and if a part of the gas system is replaced. The appliance should also be inspected before each use and at least annually by a professional. More frequent cleaning may be required, if necessary. It is imperative that the control compartment, burners, and circulating air passageways of the appliance be kept clean.



WARNING: DO NOT USE AN OPEN FLAME TO CHECK FOR LEAKS



WARNING: Be certain no sparks or open flames are in the area while you check for leaks. Sparks or open flames will result in a fire or explosion, damage to property, serious bodily injury, or death.

LEAK TESTING: Do not smoke while performing this test, and remove all sources of ignition. See leak testing diagram for areas to check. Turn all burner controls to the off position. Turn gas supply valve on. Brush a half-and-half solution of liquid soap and water onto all joints and connections of the regulator, hose, manifolds, and valves. Bubbles will indicate a gas leak. Either tighten the loose joint or have the part replaced with one recommended by your dealer. Have the appliance inspected by a professional.

If the leak cannot be stopped, immediately shut off the gas supply, disconnect it, and have the appliance inspected by a professional. Do not use the appliance until the leaks have been corrected.

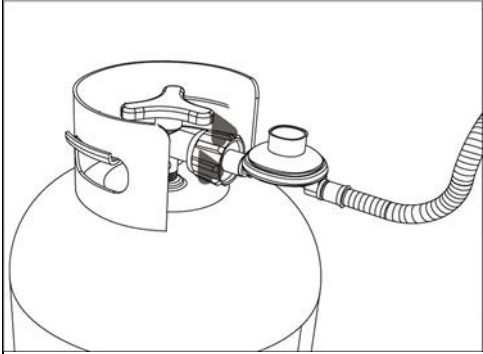
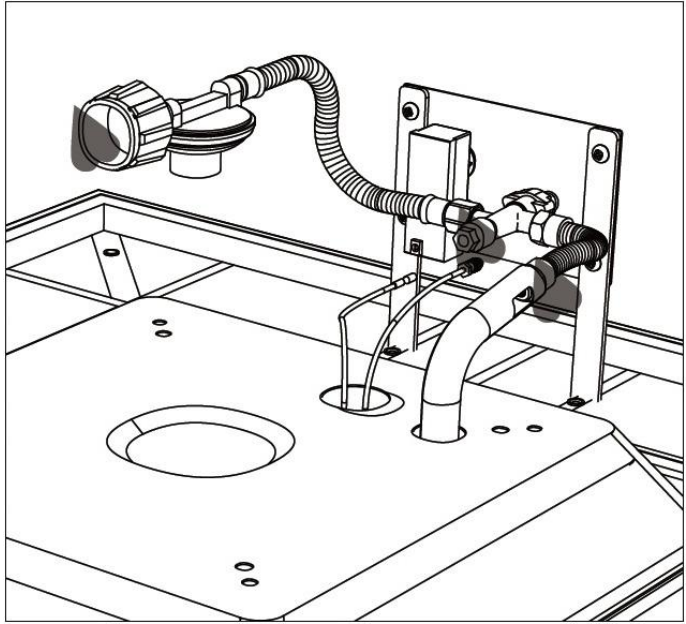
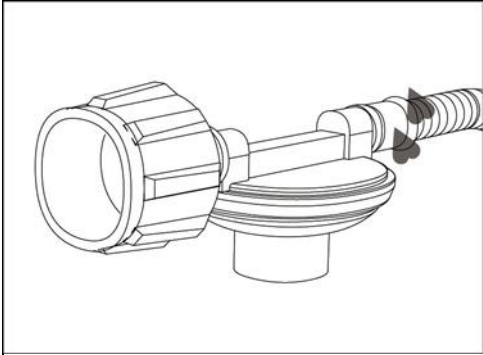

OPERATING (CONTINUED)



WARNING: Never use this appliance for other than the intended use. DO NOT use this appliance to prepare food.

Initial Lighting: When lit for the first time, the appliance emits a slight odor. This is a normal temporary condition caused by the “burn-off” of internal paints and lubricants used in the manufacturing process and does not occur again. Run the burner on high for approximately thirty minutes.



WARNING:

Children and adults should be alerted to the hazards of high surface temperatures and should stay away from the appliance to avoid burns or clothing ignition.

Never leave this appliance unattended when hot or in use. Keep out of reach of children.

Clothing or other flammable materials should not hang over, on, or near the appliance.

Keep the ventilation opening(s) of the cylinder enclosure free and clear from debris.

Any guard or protective device removed for servicing the appliance must be replaced prior to operating the appliance. Installation and repair should be done by a professional.



WARNING:

Never use the appliance while it is raining. Always turn the appliance off when raining.

Prior to use, check for damaged parts such as burner, regulator, pilot or hose. Ensure that no debris such as leaves, grass, or other objects have entered or are on the burner.

Never use the appliance if the burner is damaged. If any one of the burner, regulator, or pilot is damaged, it must be replaced prior to using this appliance with a replacement table top with burner (C) specified by the manufacturer.

If there is evidence of excessive abrasion or wear on the hose, or if the hose is damaged, it must be replaced prior to using the appliance with a replacement hose assembly specified by the manufacture.

OPERATING (CONTINUED)

LIGHTING INSTRUCTIONS

TO LIGHT:

1. Check to make sure burner controls are in the off position. Slowly turn on the gas supply valve.
2. Press and hold electric igniter button.
3. Turn the burner control to the high position. Press and hold until the burner lights. Release the electric igniter button while still holding the burner control knob.
4. Continue to depress the burner control knob for 30 seconds and then release. If the flame goes out, repeat the procedure.
5. Adjust the flame to the desired height with the burner control knob. Visually check the burner flames as pictured below.

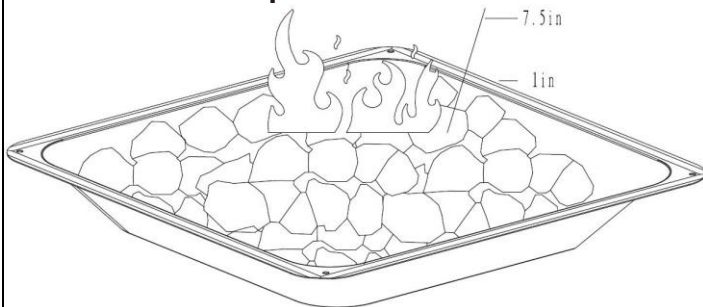

Normal

6. If the burner will not light with the electric igniter, hold a lit long match or a lit long butane lighter to the ignition area of the burner. Continue with Step 2. If the burner does not light within 10 seconds, turn the valve off and wait 5 minutes for any gas to dissipate before repeating the procedure.

TO SHUT OFF:

1. Turn the burner control knob to off position. Turn the gas off at the source (propane cylinder valve).

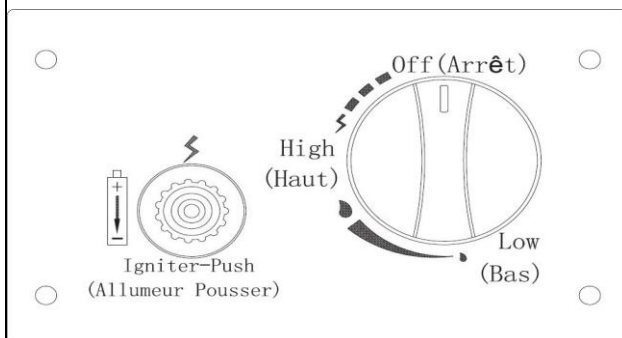

WARNING: FOR YOUR SAFETY:

The propane cylinder is equipped with an excess flow device. Unless burners are turned off prior to turning the cylinder on, only small flames and low heat will be achievable.

TROUBLESHOOTING

PROBLEM	PROBLEM CAUSE	SOLUTION
The flame is low when the valve is turned to high.	The propane lighting procedure was not followed correctly.	Ensure lighting procedure is followed carefully. The valve must be in the off position when the tank valve is turned on. Then turn the tank on slowly to allow pressure to equalize. See Lighting Instructions in the Operating section.
Burners burn with yellow flame, accompanied by the smell of gas.	There is possibly a spider web or other debris blocking some air passage.	Thoroughly clean the burner holes. See the Care And Cleaning section.
The burner will not light with the igniter, but will light with a match.	<ol style="list-style-type: none"> 1. The battery is either dead or installed incorrectly. 2. There is a loose electrode wire or switch terminal wires. 	<ol style="list-style-type: none"> 1. Check the installation or replace with a new battery. 2. Check that the electrode wire is firmly pushed onto the terminal on the back of the igniter. Check that the lead wires from the module to the ignition switch (if equipped) are firmly pushed onto their respective terminals.
The burner will not stay lit when control knob is released.	<ol style="list-style-type: none"> 1. The knob is not being held in long enough. 2. It is too windy outside. 3. Rocks or debris are in the ignition area of the burner preventing the thermocouple from being fully engulfed in flame. 4. Either the thermocouple connection or thermocouple is dirty. 5. Either the thermocouple or valve is faulty. 	<ol style="list-style-type: none"> 1. The thermocouple must have time to heat up. Hold the knob in for 30 seconds after the burner lights, then release. 2. The burner will shut down if winds are greater than 10 mph (16 km/h). Either relocate the fire pit to a different area or use when it is less windy. 3. Ensure there is no lava rocks or other debris in the ignition area, and that the small hole below the thermocouple is unobstructed. 4. Clean the thermocouple and clean the connection between the valve and thermocouple. Ensure the connection is properly tightened. 5. Replace thermocouple and/or valve.
The regulator is humming.	This is a normal occurrence on hot days.	This is not a defect. It is caused by internal vibrations in the regulator and does not affect the performance or safety of the gas heater. Humming regulator will not be replaced.
The valve is set to high but there is low heat output. There is also a rumbling noise and a fluttering blue flame at the burner surface.	<ol style="list-style-type: none"> 1. There is not enough gas. 2. The supply hose is pinched. 3. The burner orifice is either dirty or clogged. 4. There are spider webs or other matter in burner tube. 5. The propane regulator is in a "low flow" state. 	<ol style="list-style-type: none"> 1. Check the gas level in the propane cylinder. 2. Reposition the supply hose as necessary. 3. Clean the burner orifice. 4. Clean out the burner tube. 5. Ensure the lighting procedure is followed carefully. All valves must be in the off position when the tank valve is turned on. Turn tank on slowly to allow pressure to equalize. See the Lighting Instructions in the Operating section.



ONE YEAR LIMITED WARRANTY

Royal Garden branded products are warranted to the original retail buyer if the furniture frames or welds fail structurally within one (1) year from the date of purchase.

Royal Garden will repair or replace the part/piece at our discretion. Replacement will be in the original color and style whenever possible, however equal value replacement will be offered in the event of product discontinuance. Royal Garden warrants the powder coat finish for one (1) year from the date of purchase including blistering or peeling. Warranty period is for one (1) year for the structural integrity of wicker and one (1) year for cushions, fabrics, table tops, ground bumpers, bolts, washers, and umbrellas. This Limited Warranty applies to residential use only and does not apply to normal wear and tear or fading.

This product is NOT intended for commercial use and will void the warranty. Royal Garden does not warrant against acts of nature such as freezing, wind damage, fires, rain, and etc. In addition Royal Garden will not be liable for any shipping charges to or from the distribution center on merchandise returned after 12 months from the date of purchase. Royal Garden reserves the right to request that goods be returned to the distribution center for inspection or a picture to substantiate the claim.

Purchase Date : _____

Original proof of purchase must accompany all warranty claims.

Questions, problems, or missing parts?

Before returning to the store, call Royal Garden Customer Service.

866-988-3300

8 a.m. -5 p.m., PST Monday - Friday

Retain this manual for future use.

2 Pack Steel Lounge Chairs With Cushions Assembly Instructions



Item#SENRCH203





If you have any problems with this product,
(missing or damaged parts, assembly issues, etc.),
Contact us directly for fastest service:

customerservice@royalgarden.com

Call us on our Toll-Free Customer Service Hotline:
8 a.m. -5 p.m., PST Monday - Friday
866-988-3300

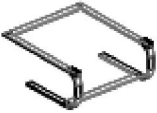

2 Pack Steel Lounge Chairs With Cushions
Item#SENRCH203

PART	QTY	PICTURE
A	2	
B	2	
C	2	
D	2	

PART	QTY	PICTURE
AA	8	

ATTENTION:

- 1 . To avoid damage of your new patio furniture, please use either the carton or another soft surface such as carpet to prevent product scratches during assembly.
2. To better line up assembly points, loosely tighten bolts until the furniture is fully assembled. . Then fully tighten bolts .

2 Pack Steel Lounge Chairs With Cushions
Item#SENRCH203



Step 1:

Step 2:

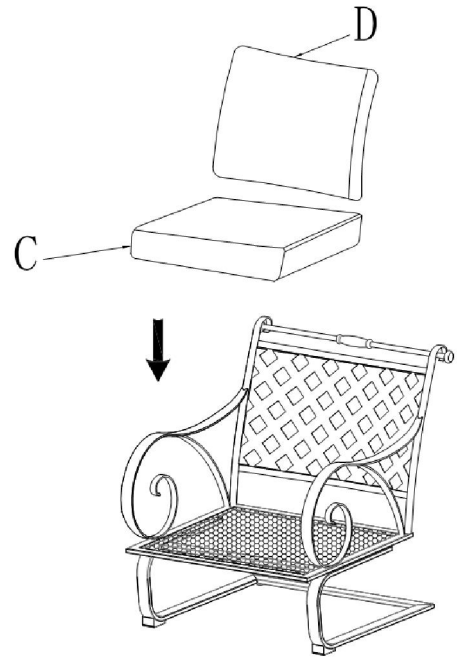
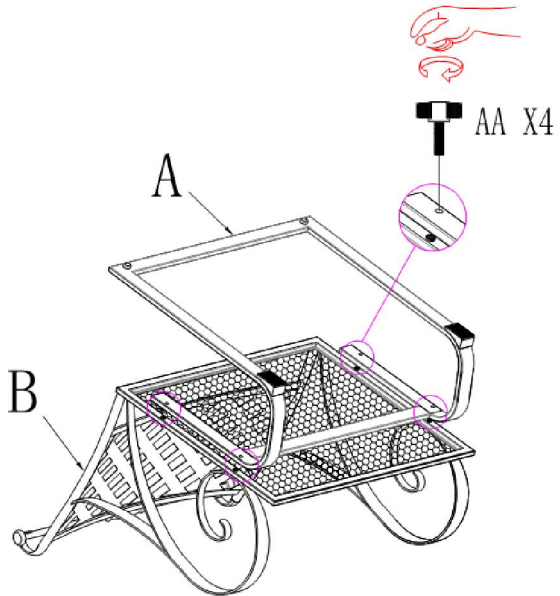

- About Your New Outdoor Furniture -



IMPORTANT

If you have any problems with this product (missing or damaged parts, assembly issues, etc.),

Contact us directly for fastest service

- Email Us at: customerservice@royalgarden.com
- Call our Toll-Free Customer Service Hotline at: 1-866-988-3300
Between 8:00 AM and 5:00 PM PST, Monday through Friday

****To expedite any future warranty claims please retain your Assembly Instructions with the product ID #, warranty sheet information, and original receipt for future use.**

Care and Maintenance

Frames

Considered the most durable material for outdoor furniture, metal can last a lifetime if you take care of it properly. Most metal outdoor furniture is finished with paint, varnish, or powder coating to prevent rust. While aluminum doesn't rust—it can oxidize (causes pitting & dulls the finish). So maintaining your furniture will extend its life & make it easier to clean.

- Wash all frames with a solution of mild soap (like dish soap) and water.
- Rinse with clean water and dry with a soft absorbent cloth towel to remove buildup of dirt particles.
- DO NOT clean with abrasive materials or solvents to avoid scratching or damaging your set.
- Frames can be treated with a liquid wax for maximum protection against UV rays and/or salty, damp air.
- Store furniture in an upright position to prevent water building up in frames, as this will cause corrosion and freeze damage in cold climates.
- Consider covering your furniture when not in use for long periods of time (and during bouts of inclement weather).

Outdoor Grade Fabrics

Our seat cushions and pillows are constructed of stain resistant olefin fabric which wicks away moisture and dries quickly, resists fading, mildew, chemicals and insects.

- If your seat cushions have zippers so you are able to remove & machine wash cushion covers (on cold gentle cycle).
- Best to air dry them outdoors instead of tumble drying on low in dryers (to prevent shrinking).
- If your set includes cushions, slings, and/or an umbrella that is not removable they may be cleaned by hand with a solution of mild soap (like dish soap) and water, then rinse with clean water.
- Slings may be washed in the dishwasher or in the washer, Lay in the sun
- After cleaning cushion fill, tip on its side and allow to drip dry.
- DO NOT use bleach or solvents to clean any product! This will void the warranty.
- To extend the life of your cushions store during inclement weather & when not in use.

All Weather Wicker

Our wicker is designed for all weather is constructed from resin material meant for outdoor use and is manufactured to be quite hardy - making it a user friendly choice with minimal maintenance.

- Wash all wicker with a solution of mild soap (like dish soap) and water.
- Rinse with clean water and dry with a soft absorbent cloth towel to remove buildup of dirt particles.
- DO NOT clean with abrasive materials or solvents to avoid scratching or damaging your set.
- Cover or store your set when not in use. When weather is too cold, wicker can become stiff - or - a bit more elastic when it is very hot.

- *About* Your New Outdoor Furniture -

Our Warranty Program

For a period of one (1) year after date of purchase, the Manufacturer will either repair or replace defective components in accordance with this Limited Warranty. This warranty is between the Manufacturer and the original purchaser and is valid only when accompanied by the original purchaser's sales receipt showing original date of purchase and location of purchase. Replacements under this warranty revert back to the date of original purchase for future warranty.

The Manufacturer or its authorized dealer can accept or reject warranty claims based on its findings. This warranty applies in normal residential use only and is not intended for commercial use. The Manufacturer can make substitutions as required of materials, components, and sub-components of comparable value and utility. This warranty is limited to product repair or replacement (to be determined solely by the Manufacturer). Warranty return is limited to only the single affected component.

Warranty Period is for:

- Three (3) years for aluminum frames
- One (1) year for steel frames
- One (1) year for the structural integrity of wicker
- One (1) year for cushions, fabrics, table tops

This limited warranty covers only manufacturing defects and does not cover normal wear and tear, damage due to acts of nature (such as, but not limited to freezing or high winds), abuse or misuse, including chemical damage from suntan oil or other chemicals, exposure to extreme heat or cold, abrasion or excessive weight. This product is intended to be used in standard installations only. This warranty is void if the product is not used for its intended purpose. The Manufacturer disclaims liability for any aspect of installation and any inconvenience caused by a defective part of a component.

Certain items are not covered by this warranty

These include, but are not limited to the following:

1. Components subjected to abuse, including abuse intended to simulate failure.
2. Damages caused by retailer, shipper or installation crew (such as scratches, dents, tears, chips, etc.).
3. Any part which merely exhibits normal wear yet functions essentially as new, including chips, scratches or stretching of materials and stitching.
4. Tears, punctures, scratches or any damage caused by improper installation or use.
5. Damage to frames/welds resulting from improper assembly or exposure to water and/or sub-freezing temperatures is not covered. General frame rusting is not covered for steel frames.
6. Fading and/or discoloration of fabrics/cushions/straps/wicker resulting from exposure to the elements, chemicals, oils, fluids or any other cause are not covered.
7. Umbrella bases are not covered under any circumstances.
8. Items sold "as is" or floor models.
9. Acts of nature such as freezing, wind damage, fires, rain, and etc.

To make a claim:

1. Contact our Customer Service Team:
 - Email Us at: customerservice@royalgarden.com
 - Call our toll-free number at 1-866-988-3300
2. Please have available a copy of the original sales receipt along with a brief description of the problem.
3. Please also provide your email address and daytime telephone or cell phone number.

All items may be charged actual freight costs plus \$15 for handling. Repairs or replacement will be made at the Manufacturer's option. Sales and use taxes, plus shipping and handling charges are the responsibility of the consumer.

THIS IS THE ENTIRE EXCLUSIVE EXPRESS LIMITED LIABILITY. THE MANUFACTURER NEITHER MAKES NOR IS RESPONSIBLE FOR ANY OTHER WARRANTIES, EITHER EXPRESS OR IMPLIED, INCLUDING THOSE OF RETAILING DEALERS. THIS EXCLUSIVE REMEDY IS LIMITED TO RECEIPT OF A CREDIT IN CONNECTION WITH THE REPAIR OR REPLACEMENT OF ANY PRODUCT OR COMPONENT DEEMED TO BE DEFECTIVE UNDER THE TERMS AND CONDITIONS AS STATED IN THIS WARRANTY. NEITHER THE PRODUCT MANUFACTURER NOR ITS AGENTS SHALL BE LIABLE IN ANY CASE FOR INCIDENTAL, INDIRECT, SPECIAL OR CONSEQUENTIAL DAMAGES RESULTING FROM THE USE OF THIS PRODUCT OR ARISING OUT OF ANY BREACH OF THIS WARRANTY OR NEGLIGENCE EVEN IF IT HAS BEEN ADVISED OF THE POSSIBILITY OF SUCH DAMAGES. EXCEPT AS OTHERWISE MAY BE REQUIRED BY LAW, THERE ARE NO OTHER EXPRESS OR IMPLIED WARRANTIES OTHER THAN THE WARRANTY DESCRIBED HEREIN, AND ALL OTHER WARRANTIES, INCLUDING ANY IMPLIED WARRANTY OF MERCHANTABILITY OR FITNESS FOR A PARTICULAR PURPOSE ARE EXPRESSLY DISCLAIMED.