

SOHO Two Benches Instruction

44 X 12 X 18 (inch)

Components

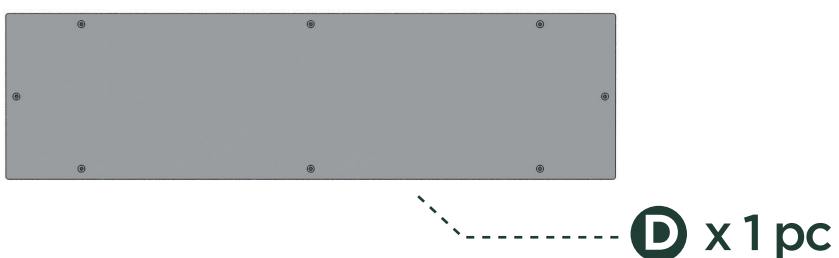
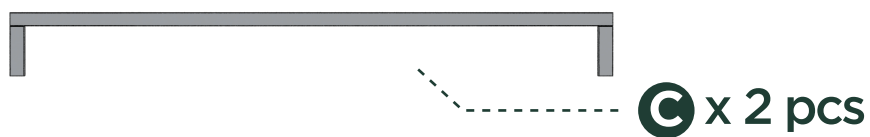

Return Policy

ZINUS believes you will absolutely love your SOHO Two Benches, but if for some reason you want to return your product please call us directly before you decide to return your product to the retailer. Our Customer Service organization can answer most concerns and can assist you with any questions you may have about your product. Please contact us first by emailing customerservice@zinusinc.com or by submitting a request at <https://support.zinus.com>. The item must be returned in good condition, in original box, with all original proof of purchase, parts and accessories, within the time frame specified by the retailer it was purchased from.

1-Year Limited Warranty Statement For Manufacturing Defects

Please read this Limited Warranty carefully. To maintain your Warranty, you will need to comply with the conditions stated here. This warranty is for manufacturing defects only and does not cover damages as a result of misuse.

1. Please be sure to register your product at www.zinus.com/resources/register to receive up to date warranty and product information.
2. Your product comes with 1 year warranty against manufacturing defects. The warranty starts on the date of purchase. No warranty will be honored without an original sales receipt. The warranty and financial responsibility of the manufacturer only applies to product itself.
3. Manufacturing defects include circumstances where product has broken under normal use. Please use your furniture safely and for the purpose it is intended. Improper use can pose a risk of injury and damage to property. Do not allow children to play or climb on this furniture. Please move furniture properly by lifting not by pushing.
4. This warranty applies only when product has been properly used by consumers who purchased product from authorized dealers as a new product. Proper use means using on a level surface with an equal distribution of weight. Proper use also means that product was not abused by the consumer, as defined by the manufacturer. This warranty does not constitute agreement to replace other parts.
5. If product fails due to manufacturing defects, the manufacturer will repair or replace at its discretion and reserves the right to substitute comparable materials or models and does not guarantee that the replacement part will match existing pieces.
6. In the event product needs to be inspected by the manufacturer to determine a warranty claim, the transportation cost or removal cost is borne by the consumer.



This unit has been designed to support the maximum weight of 300 lbs. Exceeding this limit could cause sagging, instability, product collapse, and/or serious injury. Please make sure all objects are removed before moving the assembled unit.

1

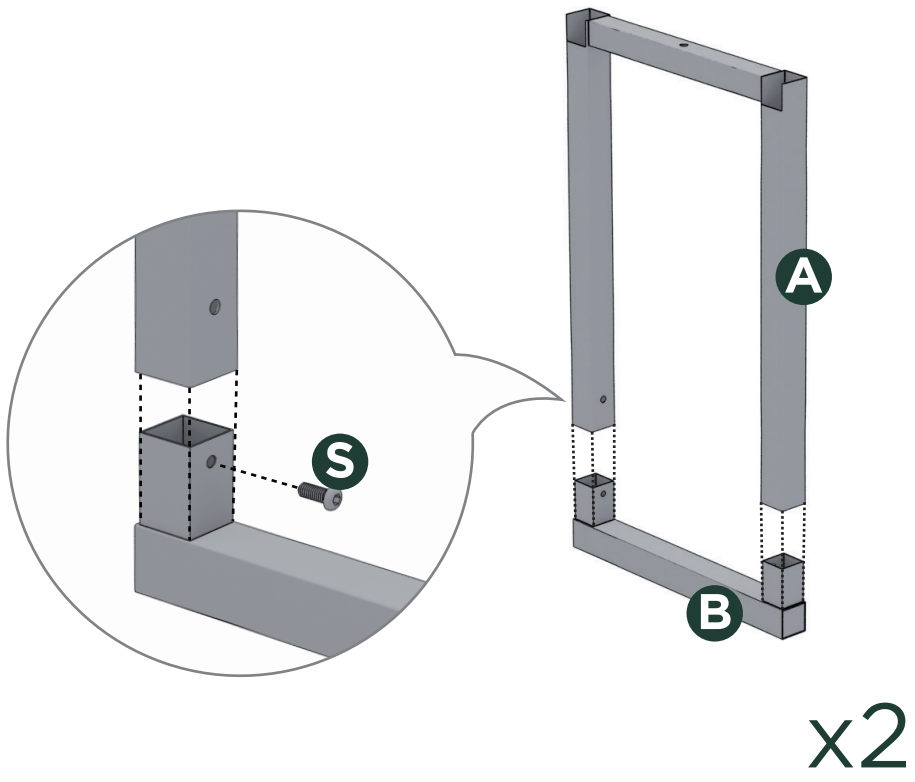

2



3

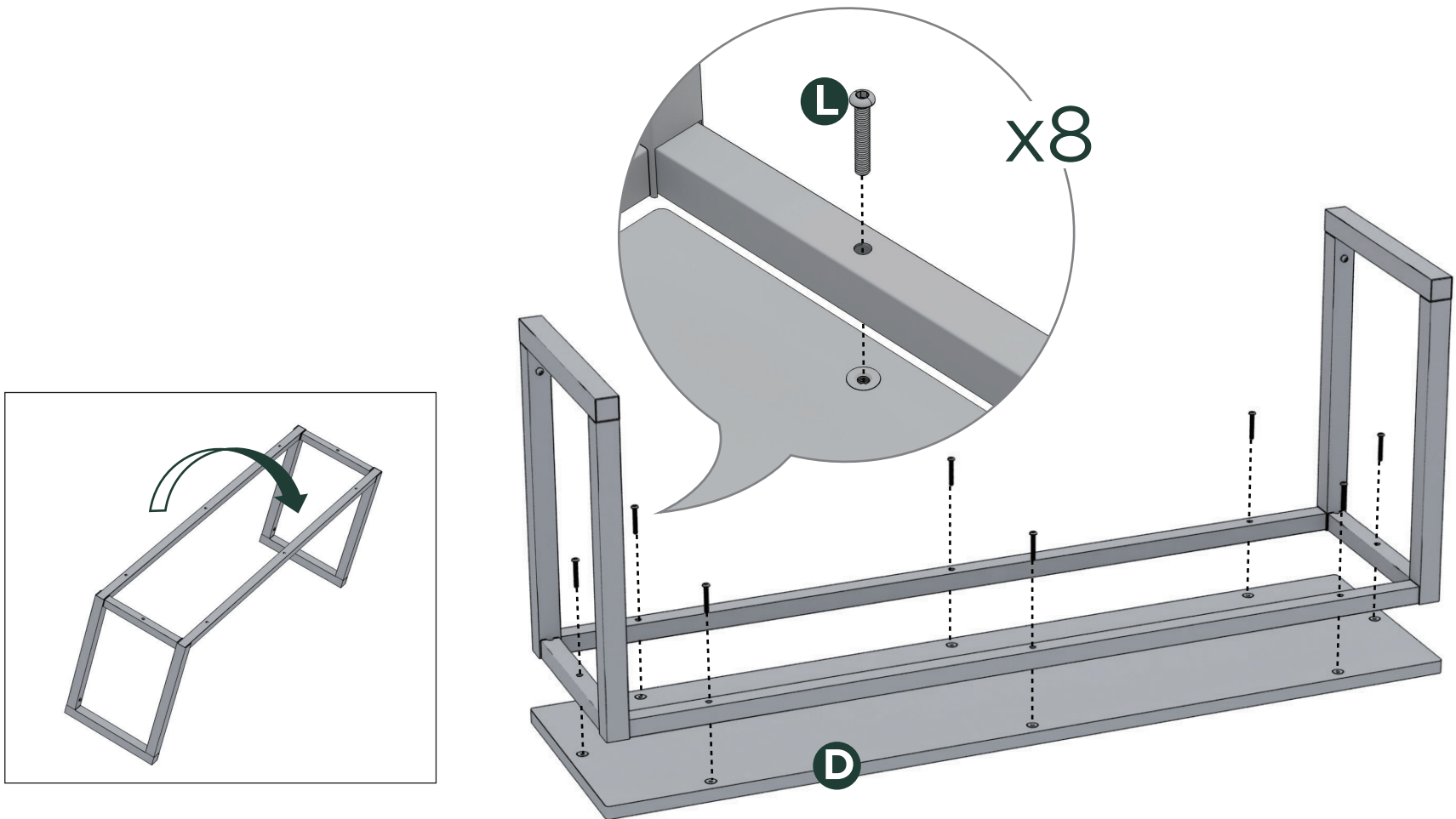

4

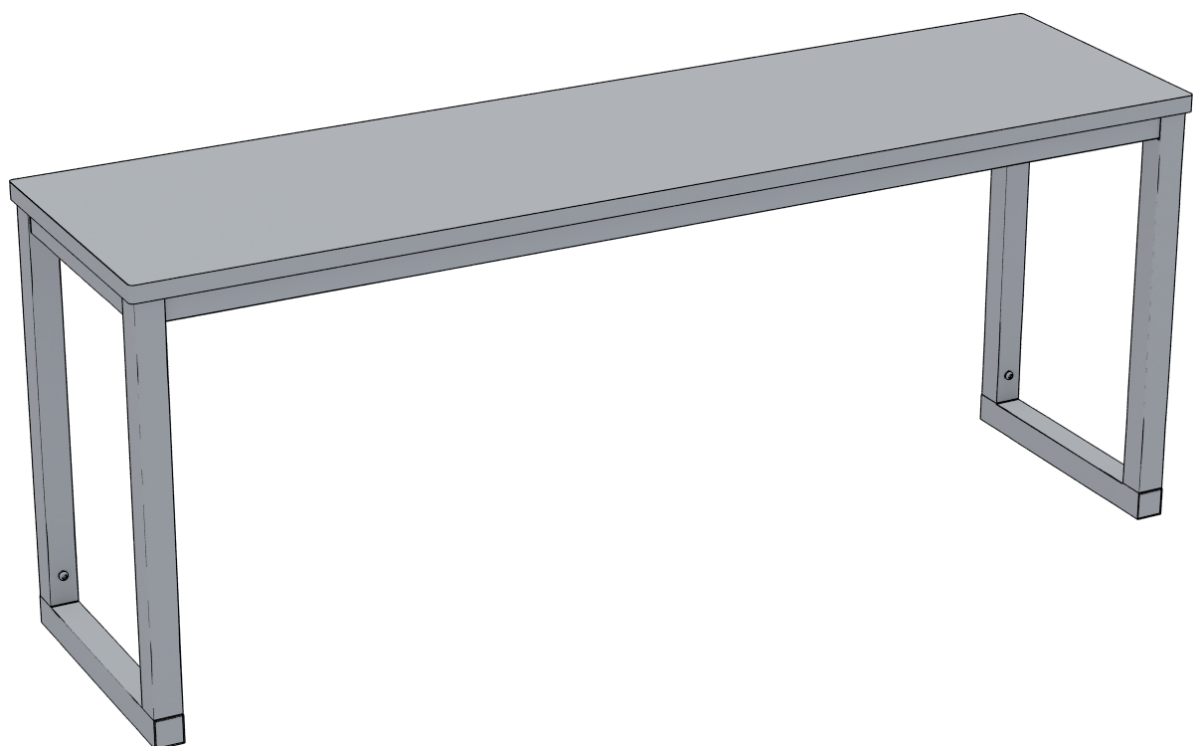

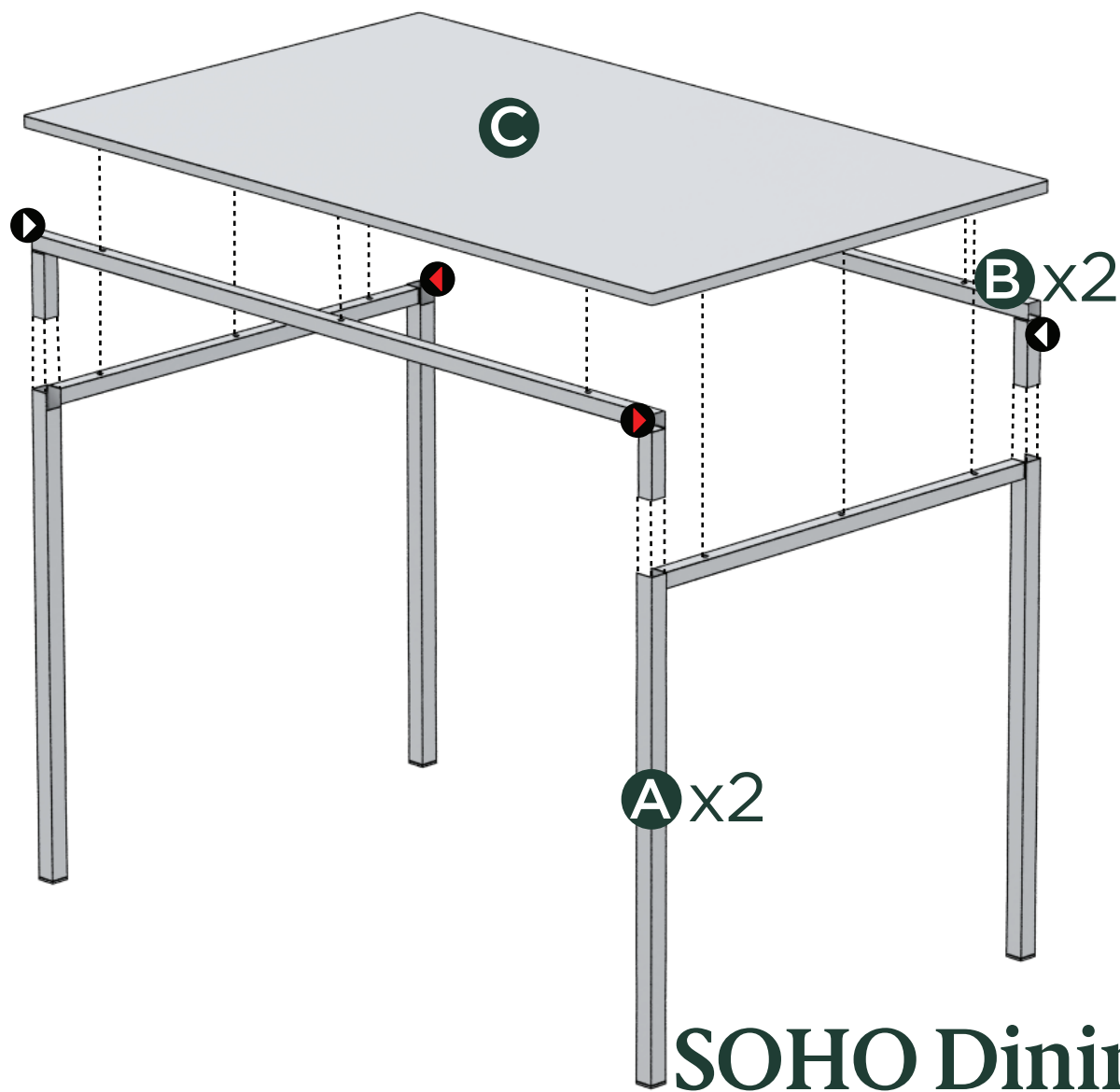

SOHO Dining Table Instruction

48 X 30 X 29 (inch)

Components

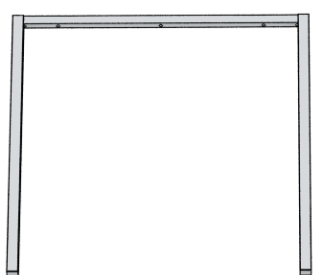

----- **A** x 2 pcs



----- **B** x 2 pcs



----- **C** x 1 pc



----- x 12 pcs



----- x 1 pc

Return Policy

ZINUS believes you will absolutely love your SOHO Dining Table, but if for some reason you want to return your product please call us directly before you decide to return your product to the retailer. Our Customer Service organization can answer most concerns and can assist you with any questions you may have about your product. Please contact us first by emailing customerservice@zinusinc.com or by submitting a request at <https://support.zinus.com>. The item must be returned in good condition, in original box, with all original proof of purchase, parts and accessories, within the time frame specified by the retailer it was purchased from.

1-Year Limited Warranty Statement For Manufacturing Defects

Please read this Limited Warranty carefully. To maintain your Warranty, you will need to comply with the conditions stated here. This warranty is for manufacturing defects only and does not cover damages as a result of misuse.

1. Please be sure to register your product at www.zinus.com/resources/register to receive up to date warranty and product information.
2. Your product comes with 1 year warranty against manufacturing defects. The warranty starts on the date of purchase. No warranty will be honored without an original sales receipt. The warranty and financial responsibility of the manufacturer only applies to product itself.
3. Manufacturing defects include circumstances where product has broken under normal use. Please use your furniture safely and for the purpose it is intended. Improper use can pose a risk of injury and damage to property. Do not allow children to play or climb on this furniture. Please move furniture properly by lifting not by pushing.
4. This warranty applies only when product has been properly used by consumers who purchased product from authorized dealers as a new product. Proper use means using on a level surface with an equal distribution of weight. Proper use also means that product was not abused by the consumer, as defined by the manufacturer. This warranty does not constitute agreement to replace other parts.
5. If product fails due to manufacturing defects, the manufacturer will repair or replace at its discretion and reserves the right to substitute comparable materials or models and does not guarantee that the replacement part will match existing pieces.
6. In the event product needs to be inspected by the manufacturer to determine a warranty claim, the transportation cost or removal cost is borne by the consumer.



This unit has been designed to support the maximum weight of 100 lbs. Exceeding this limit could cause sagging, instability, product collapse, and/or serious injury. Please make sure all objects are removed before moving the assembled unit.

1

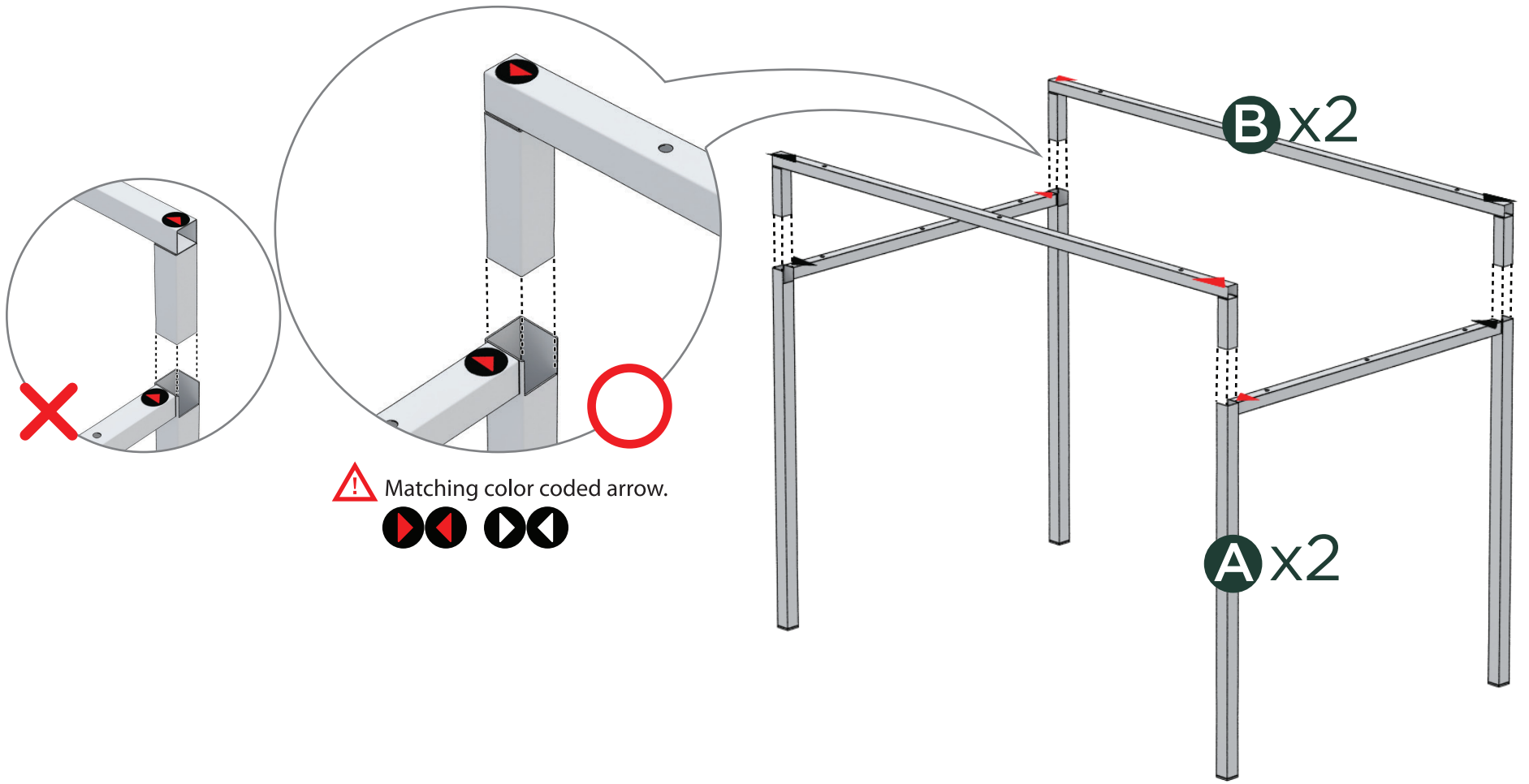

2

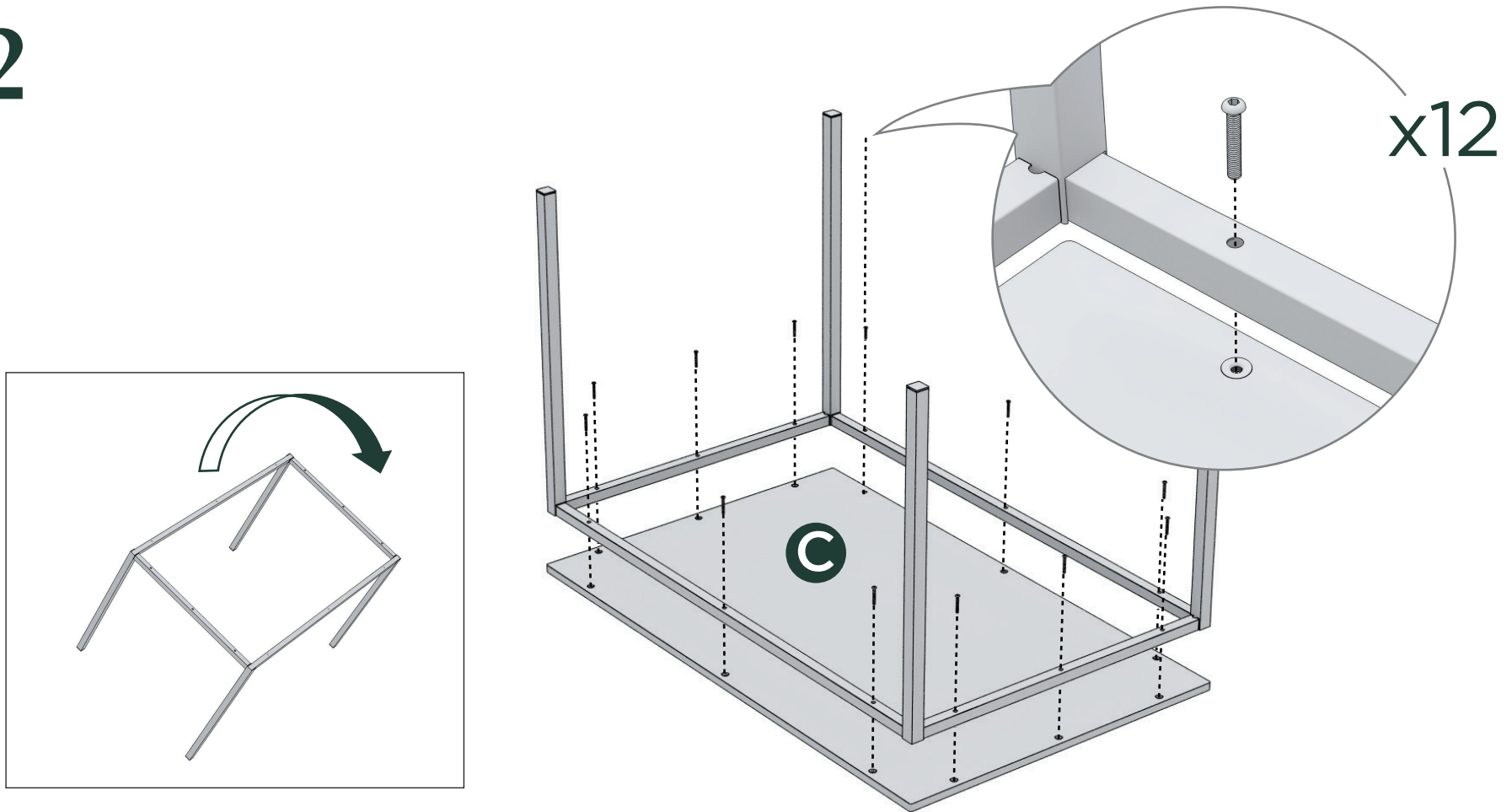

3

