

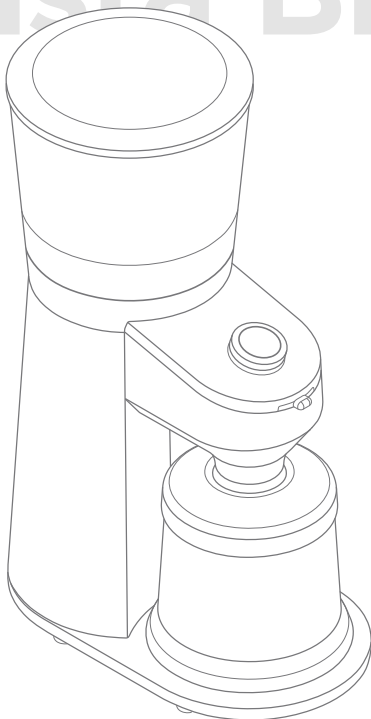

# Barista Brain



---

**CONICAL BURR COFFEE GRINDER  
WITH INTEGRATED SCALE  
INSTRUCTIONS FOR USE**

---



**CONGRATULATIONS**  
on your new OXO On appliance!

Don't forget to register your product  
at [OXO.com/registration.aspx](https://OXO.com/registration.aspx)  
for updates and other relevant information.

Although greatly appreciated, product registration is not required to activate any warranty.

---

## Perfect coffee, from the grounds up.

---

A truly perfect brew starts with ground coffee, but it takes the right grinder for coffee beans to reach their full potential. The Barista Brain Grinder's intelligent, built-in scale precisely measures coffee using pre-set grams-to-cup ratios; if you want more control, you can use the gram setting to grind exactly the amount of coffee you want.

The high torque/low speed Grinder helps keep beans from overheating during even the longest grinding session, creates a uniform grind for optimal flavor extraction, and generates minimal static to reduce mess.

Whether you like strong or weak, espresso or drip, French press or pour over, our Coffee Grinder can help you get the grind you need to make your perfect cup.

---

<b>A Note About Safety</b> .....	3	<b>Cleaning, Care and Storage</b> .....	16
<b>Before We Begin</b> .....	5	<b>Troubleshooting</b> .....	17
<b>Quick Start Guide</b> .....	6	<b>Our Guarantee</b> .....	19
<b>Meet Your Grinder</b> .....	7	<b>Registration Info</b> .....	19
<b>The Particulars of Grinding</b> .....	10		

---

## A Note About Safety



# IMPORTANT SAFEGUARDS

### Read all instructions.

When using electrical appliances, basic safety precautions should always be followed to reduce the risk of fire, electric shock, and/or injury to persons, including the following:

- **Read All Instructions.** Use this product only as described in this manual.
- Keep the packaging material (cardboard, plastic, etc.) out of the reach of children (danger of asphyxiation or injury).
- To protect against electrical shock, **do not immerse the power plug, power cord or Grinder in water or any other liquid.**
- Close supervision is necessary when any appliance is used by or near children.
- Always use the appliance on a dry, level surface.
- Do not place the appliance near the edge of a bench or table during operation. Vibration during operation may cause the appliance to move.
- Do not place the appliance on or near a hot gas or electric burner, or where it could touch any other source of heat.
- Do not allow the power cord to hang over the edge of a table or counter, touch hot surfaces or become knotted.
- Avoid contact with moving parts.
- Check the bean hopper for presence of foreign objects before using.
- Do not put any substances other than coffee beans and grinder cleaner into the Grinder.
- Unplug from outlet when not in use, before putting on or taking off parts, and before cleaning.
- Do not use appliance without lid properly placed on hopper.
- Keep area around scale clean to ensure proper function.
- The use of attachments not sold or recommended by OXO may cause fire, electric shock or injury.
- Do not leave the appliance unattended when in use.
- This appliance is not intended for use by young children without supervision. Young children should be supervised to ensure that they do not play with the appliance.
- Regularly inspect the power plug, power cord, burrs and appliance for any damage. Do not operate if damaged in any way or after the appliance malfunctions. Immediately cease use of the appliance and visit [www.oxo.com](http://www.oxo.com) or call OXO Customer Service at 1-800-545-4411 for replacement, repair or adjustment.
- **This appliance is for household use only.** Do not use the appliance for anything other than its intended purpose as described in this book. Do not use outdoors. Do not use in moving vehicles or boats.
- Do not use outdoors.

 **WARNING! Shock Hazard:** This appliance has a polarized plug (one wide blade) that reduces the risk of electric shock. The plug fits only one way into a polarized outlet. Do not defeat the safety purpose of the plug by modifying the plug in any way or using an adaptor. If the plug does not fit, reverse the plug. If it still does not fit, have an electrician replace the outlet. Do not plug this appliance into an outlet with a voltage other than specified on the bottom of this appliance. Do not use an adapter with this appliance.

### SHORT CORD STATEMENT

The length of the cord used on this appliance was selected to reduce the hazards of becoming tangled in, or tripping over a longer cord. If a longer cord is necessary, an approved extension cord may be used. The electrical rating of the extension cord must be equal to or greater than the rating of this appliance.

Care must be taken to arrange the extension cord so that it will not drape over the countertop or tabletop where it can be pulled on by children or tripped over.

To avoid an electrical circuit overload, do not use any high wattage appliance on the same circuit with this appliance.

## SAVE THESE INSTRUCTIONS.

 **WARNING!** 

**SHOCK HAZARD**

ONLY FOR USE WITH 110V AC OUTLET.  
DO NOT USE ADAPTER.

FAILURE TO FOLLOW THESE INSTRUCTIONS CAN  
RESULT IN DEATH, FIRE OR ELECTRICAL SHOCK.

 This symbol alerts you to important operating and service instructions.

 **WARNING!**   
RISK OF FIRE OR ELECTRIC SHOCK  
DO NOT OPEN

WARNING, TO REDUCE THE RISK OF FIRE OR ELECTRIC SHOCK,  
DO NOT REMOVE COVER (OR BACK)  
NO USER-SERVICEABLE PARTS INSIDE

REPAIR SHOULD BE DONE BY AUTHORIZED SERVICE PERSONNEL ONLY

 This symbol alerts you to the risk of fire or electric shock in the accompanying message.

## Before We Begin

1. Remove and recycle or discard all stickers, descriptive labels, cable ties and packing materials, including static stickers and hangtags with ties.
  2. Wipe body of appliance with a soft, damp cloth. Rinse hopper and ground coffee container and dry thoroughly.
- ⚠ CAUTION:** Do not use abrasive pads, harsh chemicals or spray cleaner chemicals to clean. These may damage the surface of the appliance. Do not put any part of your Grinder in the dishwasher.
3. Set the metal plate on the base and the ground coffee container on top of the metal plate.

## Quick Start Guide

1. Remove lid from hopper at top and fill with whole, roasted beans. Place lid back on hopper.
2. Select grind size by holding top of hopper and twisting. (1 = fine, 15 = coarse)
3. Plug into 110V outlet.
4. Choose number of cups by twisting dial and press OXO button to start Grinder.
5. While you are waiting for your beans to grind, please read on for additional features and functions.

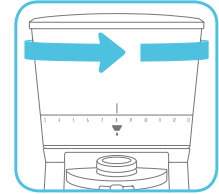

*Regularly clean the burrs of your Grinder with a brush to avoid clogging and to lengthen the life of the product. See “Cleaning, Care and Storage” on pg. 16 for more details.*



### LARGE CAPACITY BEAN HOPPER

Hopper holds 16 oz of coffee beans



### STAINLESS STEEL CONICAL BURRS

Durable 40mm burrs create a precise, uniform grind for optimal brewing



### GRIND SELECT FEATURE

Grinder locks into a wide range of settings from fine for espresso to coarse for French press coffee



### INTUITIVE LED INTERFACE

Grind based on number of cups you want to make or customize your brew by grinding in grams



### POWERFUL DC MOTOR

High torque/low speed (400 rpm) Grinder will not overheat beans, protecting flavor even during extended grinding, and generates minimal static to reduce mess

### GROUND COFFEE CONTAINER WITH TWIST-OFF LID

Container accommodates enough ground coffee to brew 12 cups

### REMOVABLE METAL PLATE

## Meet Your Coffee Grinder



### UV-BLOCKING TINT

Hopper keeps harmful UV rays away from delicate coffee beans to keep them fresh longer



### MESS-FREE DESIGN

Hopper features a “trap door” to hold beans in when removed; ground coffee container features a narrow top opening for less mess and easy dispensing



### STRENGTH ADJUSTER

Ratio can be fine-tuned to make a stronger or weaker brew to suit your preference

**NOTE:** Applies only to “cups” mode.



### PROTECTION

Built-in overheating protection and automatic no-bean detector protect the motor to ensure a long life



### BUILT-IN DIGITAL SCALE

Grinder’s intelligent, integrated scale measures output by weight instead of time, ensuring the precise amount of ground coffee every time

## ICONS

Familiarize yourself with the different scenarios you may encounter when using your Grinder. You can also reference the Troubleshooting section on pg. 17 for more information.



'Cups' selection mode. See pg. 11.



'Grams' selection mode. See pg. 12.



Portafilter icon for manual/portafilter mode. See pg. 12.



**No beans warning**—beans are not reaching the grinding burrs. Unplug the Grinder and dislodge stuck beans. If hopper is empty, fill with fresh beans.



& Solid Red Ring  
Around OXO Button

**Overheat warning**—Grinder is too hot. Grinder will pause function for a few minutes to cool down. Once the warning icon disappears, the Grinder will be ready to use again.

-or-

**Stalled motor warning**—something may be stuck in the burrs. Unplug your Grinder and clean the burrs according to instructions on pg 16. If problem persists, use cleaning granules.



& Solid Red Ring  
Around OXO Button

Tare is not done properly or a component (stainless steel plate, container, lid) is missing. Refer to "To Switch Grinder Container" section on pg. 13.

## The Particulars of Grinding

### TO SET GRIND SIZE

Optimal grind size depends on many factors including brewing method, roast darkness, bean type and freshness, and more. Experiment with different grind settings to achieve the brew that best suits your taste. If your coffee tastes too bitter, try a coarser grind size. If your brew is weak, adjust to a finer grind size.

1. Remove lid from hopper and fill with whole, roasted beans. Place lid back on hopper.
2. Grip the hopper from the top and slowly rotate to adjust the grind size setting (1 = fine, 15 = coarse). See chart below for grind setting recommendations.

**NOTE:** Adjust the grind size while the motor is running to prevent jamming.

3. Plug into 110V outlet.
4. See pg. 11 for instructions on grinding by number of cups, and pg. 12 for instructions on grinding by grams or grinding manually.

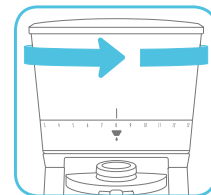

### GRIND SIZE SETTING RECOMMENDATIONS

Brewing Method	Espresso	Pour Over Drip Coffee	French Press Cold Brew
Suggested Grind Size	Fine	Medium	Coarse
Grind Setting	1-5	6-10	11-15

**⚠ WARNING! ⚠**

#### SHOCK HAZARD

ONLY FOR USE WITH 110V AC OUTLET.

DO NOT USE ADAPTER.

FAILURE TO FOLLOW THESE INSTRUCTIONS CAN  
RESULT IN DEATH, FIRE OR ELECTRICAL SHOCK.

## TO GRIND COFFEE

The Grinder lets you grind in 3 modes: cups, grams and manual/portafilter. In cups and grams mode the Grinder weighs output with an **integrated scale** to ensure consistent and accurate results. In manual/portafilter the integrated scale is disabled.

### Note:

- When in “cups” or “grams” mode, make sure to always have the stainless steel plate, the container and the lid on the base when grinding. If they are absent, the Grinder will not work properly. Refer to the Troubleshooting section for more details (pg. 17).
- Once Grinder has started, the display will show the weight increasing until it reaches the desired weight.
- Do not touch the container or shake the Grinder while grinding as it will affect the reading on the scale.
- Grinder will go into sleep mode after 20 seconds of no activity.
- You cannot adjust the number of cups or grams while grinding, but you can stop the grinding process at any time by pushing the OXO button.

## To Switch Between Modes

When you first plug it in, the Grinder will default to “cups mode.” To change to a different mode, hold down the OXO button for ~3 seconds, then twist the dial to select your preferred mode. Your Grinder will then default to the last mode used, even after being unplugged.

### Cups Mode

To grind based on the number of cups you wish to brew (up to 12):

1. Press the OXO button once to wake up your Grinder. Press and hold the OXO button for ~3 seconds to enter the mode selection menu.
2. Twist dial to select cups mode, then press the OXO button to select.
3. The scale will measure and display the number of cups in the ground coffee container. Twist the dial to select the **total number** of cups you would like in the ground coffee container.

For example, if there are 2 cups of ground coffee in the container, and you want a total of 8 cups of ground coffee, the number “2” will be displayed with a solid white ring around the OXO button. When you twist the dial, the ring will flash, and you can select the number “8”. When the grinding cycle is complete, you will have enough coffee in the container for 8 cups.

4. Press OXO button to grind.

OXO recommends using approximately 8 grams of ground coffee per cup (5 fl oz). If you want to adjust the pre-programmed setting to be a little less strong or a little stronger, use the strength adjuster (see “To Adjust Coffee Strength” on pg. 13).

Cups	1	2	3	4	5	6	7	8	9	10	11	12
Grams	8	16	24	33	41	49	57	65	73	81	89	98

(Grams rounded to nearest whole number)

Note: Coffee dosage recommendations are based on the SCAA gold cup ratio designed for optimal extraction and strength.

### Grams Mode

If you already know how many grams you need for your favorite brewing method, you can grind by grams by selecting your desired quantity, from 1 to 125 grams.

1. Press the OXO button once to wake up your Grinder. Press and hold the OXO button for ~3 seconds to enter the mode selection menu.
2. Twist dial to select grams mode, then press the OXO button to select.
3. The scale will measure and display the number of grams in the ground coffee container. Twist the dial to select the **total number** of grams you would like in the ground coffee container.  
For example, if there are 16 grams of ground coffee in the ground coffee container, and you want a total of 65 grams of ground coffee, the number “16” will be displayed with a solid white ring around the OXO button. When you twist the dial, the ring will flash, and you can select the number “65”. When the grinding cycle is complete, you will have 65 grams of ground coffee in the ground coffee container.
4. Press OXO button to grind.



### Manual/Portafilter Mode

You can disable the Grinder’s built-in scale if you want to manually determine the amount of coffee to grind or if you want to grind directly into a portafilter (☞☞). In the manual mode, the display selection is disabled: you cannot select cups or grams.

1. Once manual mode is selected, you can grind into the ground coffee container or a different container, or you can remove the ground coffee container and place a portafilter under the chute. For more information see “To Switch Ground Coffee Container” on pg. 13.
2. Press OXO button to start grinding.
3. Press OXO button again to stop grinding.



## TO ADJUST COFFEE STRENGTH

If you find your coffee too weak or too strong, you can fine tune the dosage for next time.

1. Move the Strength Adjuster to the right to add a little more ground coffee, or to the left for a little less. Each position of the Strength Adjuster represents a change of one gram per cup.

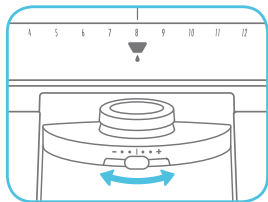

For example, if you select 4 cups and move the Strength Adjuster one position to the right, the Grinder will produce an additional 4 grams. (4 x 8 grams + 4 x 1 gram = 36 grams)

### Note:

- The Strength Adjuster only works in cups mode.
- Never overfill the ground coffee container. Grounds can back up, block the grounds chute and jam or burn out the motor.

**⚠ Caution:** Do not operate this appliance for longer than 4 minutes at a time as this can cause overheating. Allow Grinder to cool for at least 2 minutes after each use. Allow the appliance to cool down 10-15 minutes after long operation. If the motor overheats, the Grinder will stop working. The display will show a 30 minute countdown during which you cannot use the Grinder. Wait until the countdown has ended before using the Grinder again.

## TO SWITCH GROUND COFFEE CONTAINER or ZERO THE SCALE

The Grinder is designed and programmed to work with the steel plate, ground coffee container and lid it comes with.

If you prefer to grind in a different container than the one provided with the unit, you will have to tare the machine (which will set the scale to zero) with the new container on the scale.

1. Place the container you decide to use on the base. It can be a different container or our container without the lid or the steel plate, whatever combination works for you.
2. Press and hold the OXO button. You will pass the mode selection screen. After the mode selection, you will see a 3 second countdown. Keep holding during the countdown. When the countdown reaches "0", the Grinder will tare with the new container, display "0 g" or "0 cup" and be ready to grind.
3. The Grinder is now tared with the container you selected. If unplugged, the Grinder will remember this tare. If you decide to use a different container or switch back to the one provided with the Grinder, repeat steps 1 and 2 with new container.

## TO REMOVE/REPLACE HOPPER



Always unplug power cord from outlet before removing or replacing bean hopper.

### To Remove Hopper:

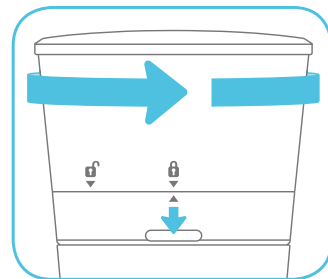
1. Press down on and hold hopper release lever on back of Grinder with one hand.
2. Keep pressing lever and twist hopper counter-clockwise with other hand until the arrow lines up with the  icon.
3. Lift hopper with lid straight up and off of the Grinder.



### To Replace Hopper:

1. Make sure there is no coffee debris on the flat surface around the burrs. For cleaning instructions, please see pg. 16.
2. Align  icon on hopper with the arrow above release button. If you do not align the  icon with the arrow, the hopper will not be installed properly and the Grinder will not work.
3. Gently slide hopper straight down onto Grinder. The hopper should seat easily and sit straight. If hopper sits crookedly, remove and try again until it sits straight.
4. Twist hopper clockwise until the arrow aligns with the  icon and release button clicks into place.

**NOTE:** The bean hopper is designed with a "trap door" that automatically closes when the hopper is removed. The "trap door" allows for easy bean changing and mess-free cleaning.

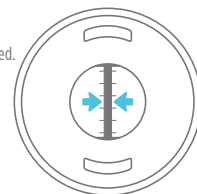

Underside of hopper



## Good Tips

- Freshly ground coffee is key to making better coffee. OXO recommends grinding coffee immediately before brewing.
- If you don't grind regularly, make sure to clear the ground coffee from the chute before each use, as some older coffee dust may be sitting inside your Grinder and will affect the quality of your next batch. Without adding beans to the hopper, select 1 cup and grind. Discard the grounds. You are now ready to grind your fresh beans.
- Coffee flavor and strength is a personal preference. Vary the type of coffee beans, amount of coffee and fineness of grind to achieve the flavor you prefer.
- Do not store beans in the bean hopper for an extended period of time.
- A grind size that is too fine can cause filters/brew baskets to clog and/or overflow. If you experience this, try a coarser grind size.
- Use fresh beans. Old/dry beans will create static. Excess static can lead to dust sticking to walls of Grinder.

## Cleaning, Care and Storage

Before cleaning, OXO recommends running the Grinder for 10 seconds with an empty bean hopper to help clear beans/grounds from the burrs and grounds chute.

1. Always unplug power cord from power outlet before cleaning.
2. Unlock and remove bean hopper from Grinder by pressing down on hopper release lever and twisting hopper counter-clockwise. See pg. 14 for full instructions.
3. Carefully remove any beans from between Grinder burrs.
4. Lift metal burr handle, and twist counter-clockwise. Pull handle straight up to remove upper burr.
5. Clean upper burr, lower burr and grounds chute with a small bristle brush.
6. Align indents in upper burr with tabs inside lower burr. Push upper burr straight into grinder and turn handle clockwise, until you hear a "click."

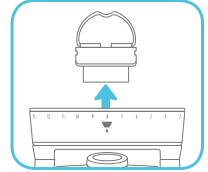

- Note:** Continue pressing down while turning handle to ensure upper burr engages with lower burr.
7. To test proper burr installment, pull metal burr handle straight up. If properly installed, burr will stay in place.
  8. Wash the ground coffee container, bean hopper and both lids in warm water and mild detergent, rinse and dry thoroughly.
  9. Wash and dry stainless steel plate and wipe free any coffee grounds sitting under plate.
  10. Replace bean hopper by aligning  icon with arrow, then gently seat hopper straight down.
  11. Wipe Grinder exterior with a soft, damp cloth.

**Note:** Do not use abrasive pads or harsh chemicals to clean Grinder. Do not wash any part of your Grinder in the dishwasher.

### **WARNING!**

#### **ELECTRICAL SHOCK HAZARD:**

**NEVER IMMERSE THIS APPLIANCE, POWER CORD OR POWER PLUG IN WATER OR ANY OTHER LIQUID. DOING SO CAN RESULT IN DEATH OR ELECTRICAL SHOCK.**

### **WARNING!**

#### **SHOCK HAZARD**

**ONLY FOR USE WITH 110V AC OUTLET.**

**DO NOT USE ADAPTER.**

**FAILURE TO FOLLOW THESE INSTRUCTIONS CAN RESULT IN DEATH, FIRE OR ELECTRICAL SHOCK.**

## Troubleshooting

Problem	Possible Cause	Solution
<b>Grinder does not start after pressing the OXO button</b>	Grinder not plugged in	Plug power cord into 110V outlet.
	Bean hopper not attached properly	Gently remove and re-install bean hopper ensuring it is seated properly.
	Grinder overheated	Grinder will pause function for a few minutes to cool down. Once the warning icon disappears, the Grinder will be ready to use again.
	If you see “☹ ☹” and nothing happens, scale is not tared properly.	Check that stainless steel plate, ground container and lid are on the scale. Tare scale again. Refer to the “To Switch Grinding Container” section on pg. 13.
<b>Grinder stops mid-cycle</b>	No beans in hopper	Fill hopper with fresh coffee beans.
	Foreign item trapped in burrs	Unplug power cord and remove hopper. Inspect hopper, upper and lower burrs. Remove any foreign objects. Refer to Cleaning and Care section.
	Grinder overheated	Grinder will pause function for a few minutes to cool down. Once the warning icon disappears, the Grinder will be ready to use again.
<b>Grinder is louder than normal</b>	Grinder blocked with foreign item	Unplug power cord and remove hopper. Inspect hopper, upper and lower burrs. Remove any foreign objects. Refer to Cleaning and Care section on pg. 16.

Problem	Possible Cause	Solution
<b>Grinder starts but produces no coffee grounds</b>	No beans in hopper	Fill hopper with fresh coffee beans.
	Hopper out feed is blocked	Unplug power cord and remove hopper. Inspect hopper, upper/lower burrs and grounds chute for blockage.
	Grounds chute is clogged	Unplug power cord and remove hopper. Use a small flexible brush to clean grounds chute.
<b>Grinder won't let me select the number of cups/grams I want</b>	The integrated scale is detecting coffee in the ground coffee container	Select the number of total cups/grams you want in the ground coffee container. See pg. 11-12 for more details.
	The scale is not tared properly and it thinks there is coffee in the ground coffee container	Check that stainless steel plate, container and lid are on the scale. Tare scale again. Refer to the “To Switch Grinding Container” section on pg. 13.
<b>Grinder display is not showing “0” when empty container is on the base/scale</b>	Tare has not been done with the container you're trying to use	Tare scale with the container you are trying to use. Refer to the “To Switch Your Ground Coffee Container” on pg. 13.





---

## It's On

---

For over 25 years, OXO's mission has been to provide innovative consumer products that make everyday living easier.

How do we do it? We study people – lefties and righties, male and female, young and old – interacting with products and we identify opportunities for meaningful improvement. Our “question everything” process and relentless attention to detail allow us to design products that help consumers make short work of everyday tasks.

We've applied the same philosophy to OXO On, our new line of intelligent kitchen appliances. Through intuitive interfaces, innovative digital controls and backlit LED displays, our On appliances give you the simplicity, functionality and thoughtfulness you've come to expect from OXO...

...all with the touch of a button.

©2015

OXO International Ltd.

1 Helen of Troy Plaza

El Paso, TX 79912

Printed in China

IB-8710200-00