

HOLLANDER / FABIAN / BERMAN

SIDEBOARD BUFFET

MODEL # AXCHLL-09

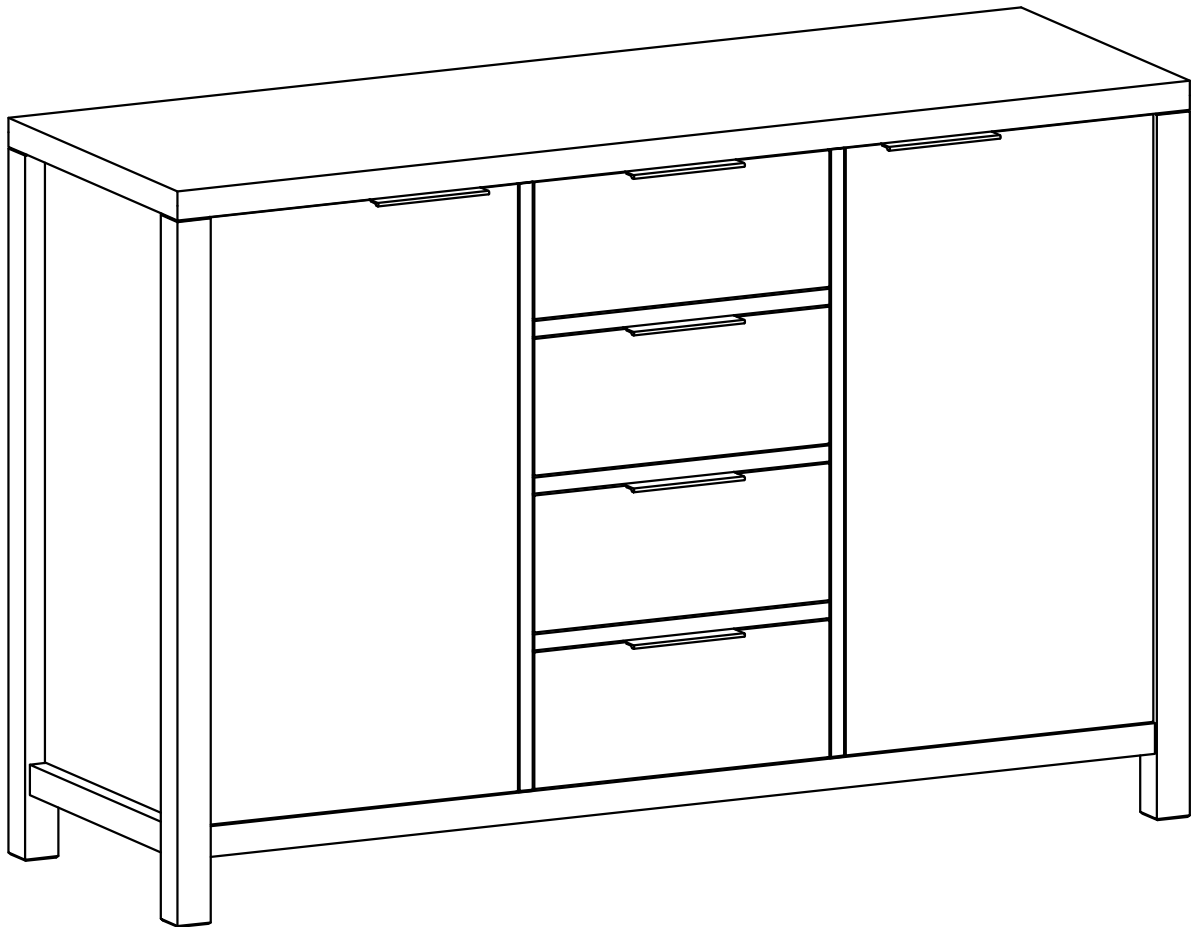



Questions, problems, assembly help, missing parts?

No need to return the product, we will gladly help and ship your replacement parts free of charge

Please call Customer Service at 1-866-518-0120 ext. 262

Monday to Friday between 9 am –4 pm EST

or go to

www.simpli-home.com/parts request

In order to assist you in a timely manner, please have the following information ready:

Model # _____ Part Number or Letter _____

Purchased at _____ Date of Purchase _____

If you wish to return the product, please contact the retailer where the product was purchased.

IMPORTANT : Please read this manual carefully before beginning assembly of this product. Keep this manual for future reference.

SAFETY INFORMATION

CAUTION: Injuries and damage can occur from furniture tip over if product is not properly anchored to the wall. Use the Furniture Anti-Tipping Restraint provided with the product. Consult our assembly instructions for help. If the Furniture Anti-Tipping Restraint kit is not in the box, please contact our customer service department in order to obtain another kit before using the furniture.

Identify all the parts and hardware. Do not discard of the packaging until you have checked that you have all of the parts and hardware required. Hardware package may have spare parts.

WARNING: This item contains small parts which can be swallowed by children and pets. Keep children and pets away during assembly. To avoid danger of suffocation, always keep plastic bags away from children and pets. We recommend that you assemble this unit on a carpeted floor to avoid scratches. If using power tools, set the tool to low torque to avoid damage.

May require 2 people for ease of assembly.

IMPORTANT : Please read this manual carefully before beginning assembly of this product. Keep this manual for future reference.

CARE and MAINTENANCE

Perhaps the greatest environmental damage to wood furniture comes from wide swings in relative humidity (RH) in our homes. Wood absorbs and desorbs water as relative humidity rises and falls, and in doing so it swells and shrinks. Making matters worse, it expands and contracts unequally along different grain directions. As humidity changes, the components of wooden objects are continually pushing and pulling against each other. This pressure often results in parts of furniture no longer fitting together closely or becoming distorted or breaking from their own internal stresses.

The response to relative humidity changes begins with determining the annual average RH for your particular space. Then try to keep the RH in the space where your furniture is as close to that average as possible, generally within about 10% up or down. De-humidify in the summer and humidify in the winter.

Be aware that raising the temperature lowers the humidity and vice versa. Thus, modern heating systems, which can drive down interior RH in the winter, almost invariably cause problems for furniture. To counteract their effect, you can either modify the RH by keeping furniture containing spaces cooler in the winter or most importantly, have a good working humidifier for your home. A humidistat automatically works to balance the humidity in your home so it is constant. Dry indoor air can suck enough moisture from its surroundings to do permanent damage to wood, causing it to crack or split.

Remember, that not all woods are created equal. Two factors that help determine how rapidly a wood will lose moisture are pore size and surface hardness. A piece made from a dense and hard wood will dry less rapidly than pieces made from softer woods.

Furniture that is sealed and lacquered will lose moisture more slowly than an unfinished piece while pieces with veneer finishes are not only stronger, but lose moisture more slowly than other finishes.

To help protect your wood furniture, take these steps:

- Use a humidifier, preferably one with an automatic control system that can sense the humidity level and adjust itself accordingly. Don't over-humidify; that can damage wood by causing it to expand and contract.
- Keep furniture out of direct sunlight, which can cause it to dry out, crack and warp.
- If you can avoid it, don't put furniture near heating vents. If you must, keep the piece 3 to 4 inches away from the wall, giving the heat and air space to circulate.
- Dust with soft dry cloth.
- Do not use liquid or aerosol products.
- To avoid marking, do not place rubber on surface (foot pads, etc.)
- For soil build-up, wipe with damp cloth & dry.
- Do not use abrasive cleaners.

PART DESCRIPTION

A

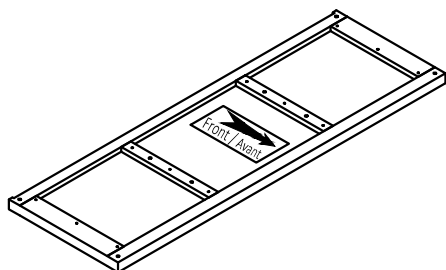

TOP
QTY 1

BL

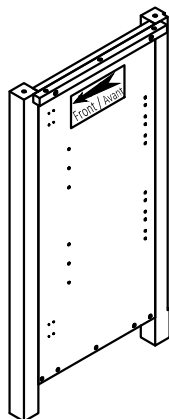

LEFT SIDE
QTY 1

BR

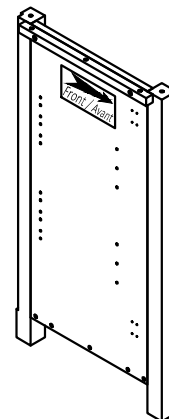

RIGHT SIDE
QTY 1

CL

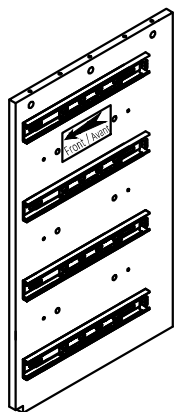

LEFT DIVIDER
QTY 1

CR

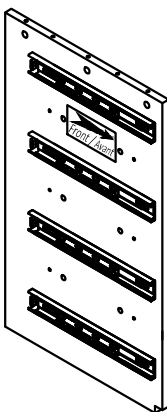

RIGHT DIVIDER
QTY 1

D

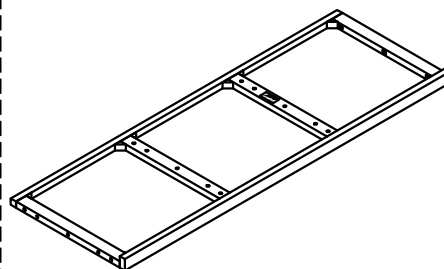

BOTTOM FRAME
QTY 1

E

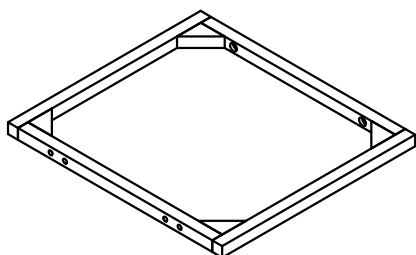

MIDDLE FRAME
QTY 3

F

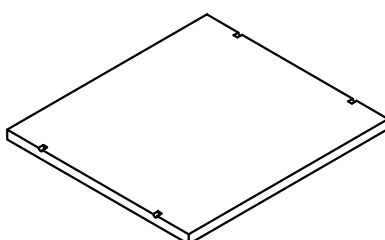

SHELF
QTY 4

G

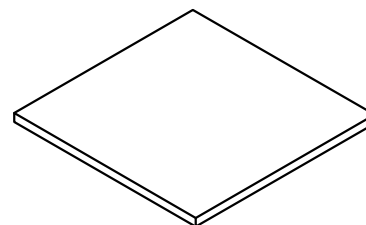

BOTTOM SHELF
QTY 2

NEED HELP? For help with assembly or if you are missing a part,
Please call customer service at 1-866-518-0120 ext. 262 (9 am to 4 pm EST)

PART DESCRIPTION

HL

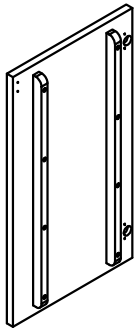

LEFT DOOR
QTY 1

HR

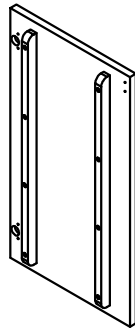

RIGHT DOOR
QTY 1

IL



LEFT BACK PANEL
QTY 1

IR

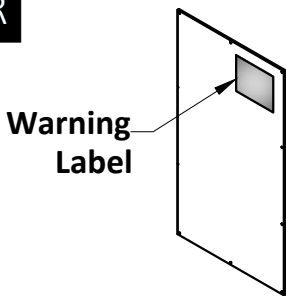

RIGHT BACK PANEL
QTY 1

I1

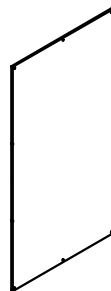

MIDDLE BACK PANEL
QTY 1

J

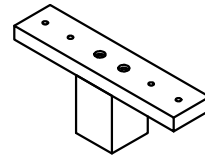

BOTTOM SUPPORT LEG
QTY 2

K

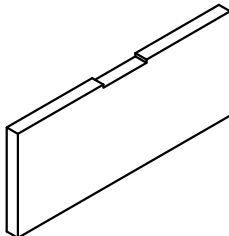

DRAWER FRONT
QTY 4

LL

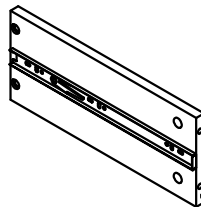

LEFT DRAWER SIDE
QTY 4

LR

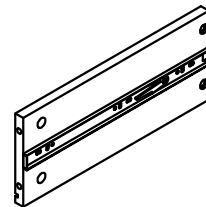

RIGHT DRAWER SIDE
QTY 4

M

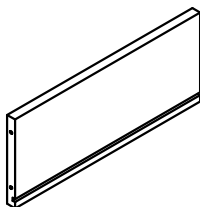

DRAWER BACK
QTY 4

N

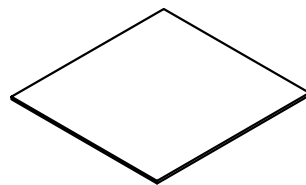

DRAWER BOTTOM
QTY 4

NEED HELP? For help with assembly or if you are missing a part,
Please call customer service at 1-866-518-0120 ext. 262 (9 am to 4 pm EST)

HARDWARE DESCRIPTION

1

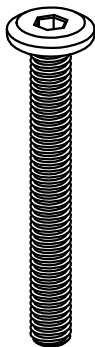

ALLEN KEY BOLT
M6 x 50 mm
QTY 6

2

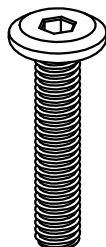

ALLEN KEY BOLT
M6 x 30 mm
QTY 6

3

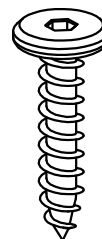

ALLEN KEY SCREW
M6 X 30mm
QTY 34

4

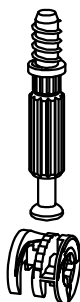

CAM LOCK PIN
CAM LOCK
QTY 22 SETS

5



ALLEN KEY
QTY 1

6



WOOD DOWEL
Ø8 X 30mm
QTY 28

7

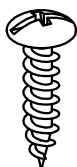

PHILLIPS SCREW ROUND HEAD
M4 X 15mm
QTY 26

8

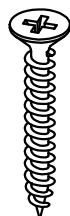

PHILLIPS SCREW
M4 X 30mm
QTY 12

9

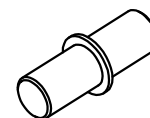

SHELF SUPPORT
QTY 24

NEED HELP? For help with assembly or if you are missing a part,
Please call customer service at 1-866-518-0120 ext. 262 (9 am to 4 pm EST)

HARDWARE DESCRIPTION

10

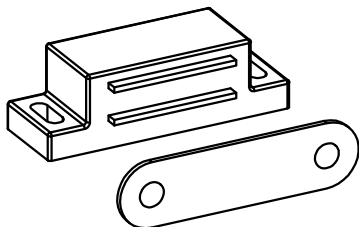

MAGNET AND PLATE
QTY 2 SETS

11

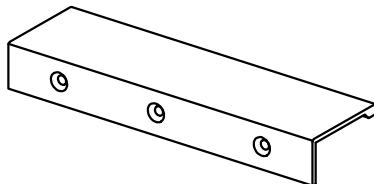

HANDLE
QTY 6

12

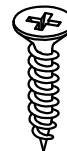

PHILLIPS SCREW
M3 X 15mm
QTY 26

13

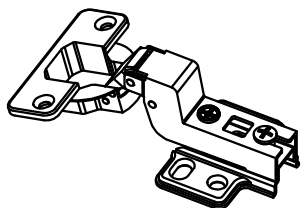

ADJUSTABLE HINGE
QTY 4



14

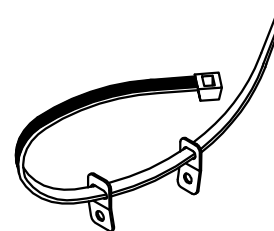

PHILLIPS SCREW
M3.5 X 15mm
QTY 24

15



- a.  M4 X 25mm - QTY 2
(1 is extra)
- b.  M4 X 15mm - QTY 1
- c.  M4 X 25mm - QTY 1

FURNITURE TIP OVER RESTRAINT
QTY 1 SET

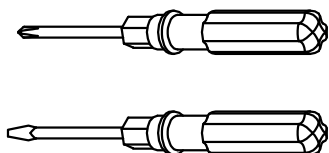

Required -
Flathead screwdriver
Phillips screwdriver
Rubber mallet
Not Included

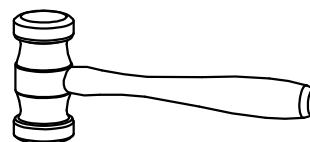

NEED HELP? For help with assembly or if you are missing a part,
Please call customer service at 1-866-518-0120 ext. 262 (9 am to 4 pm EST)

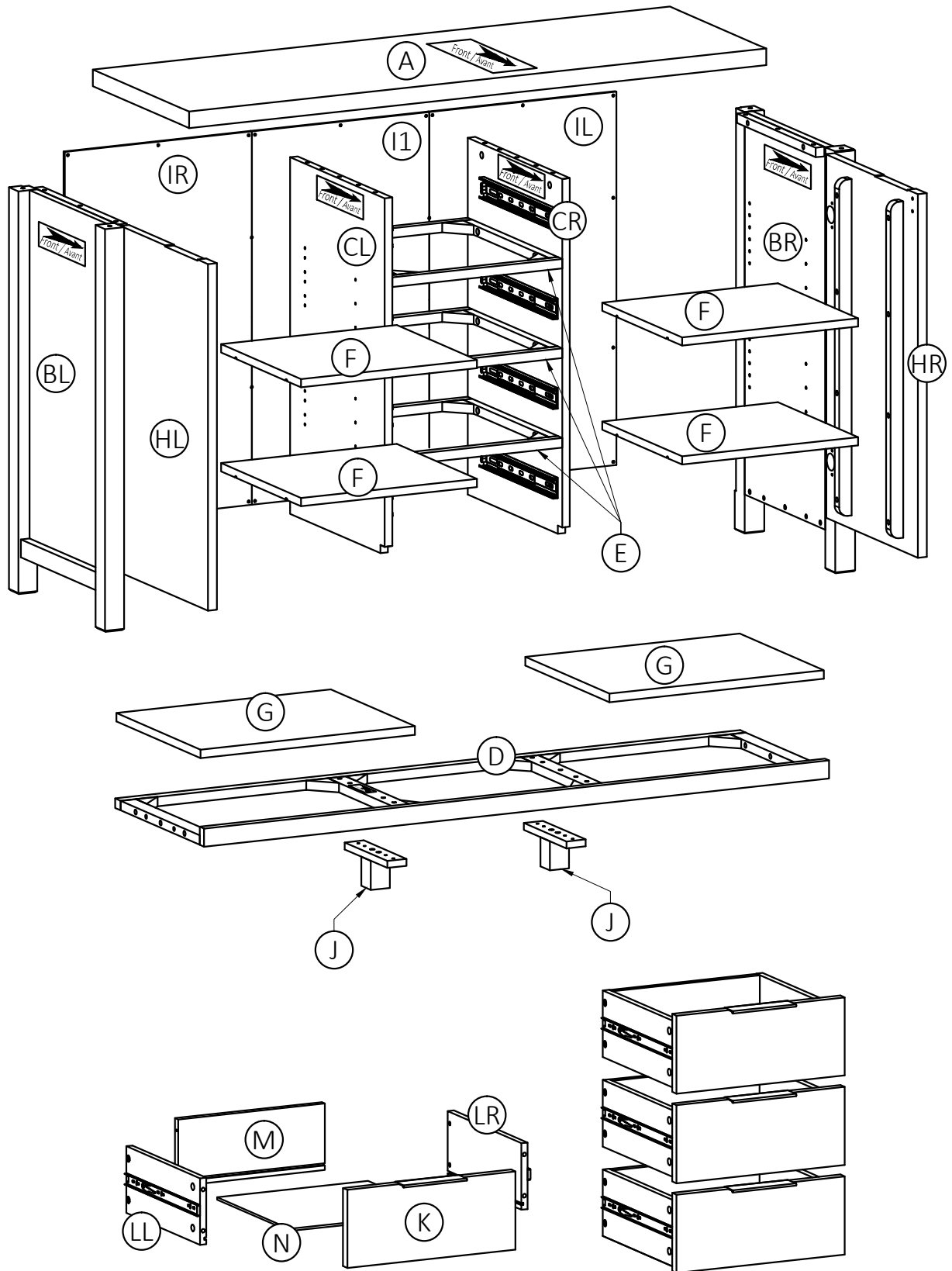

STEP-1

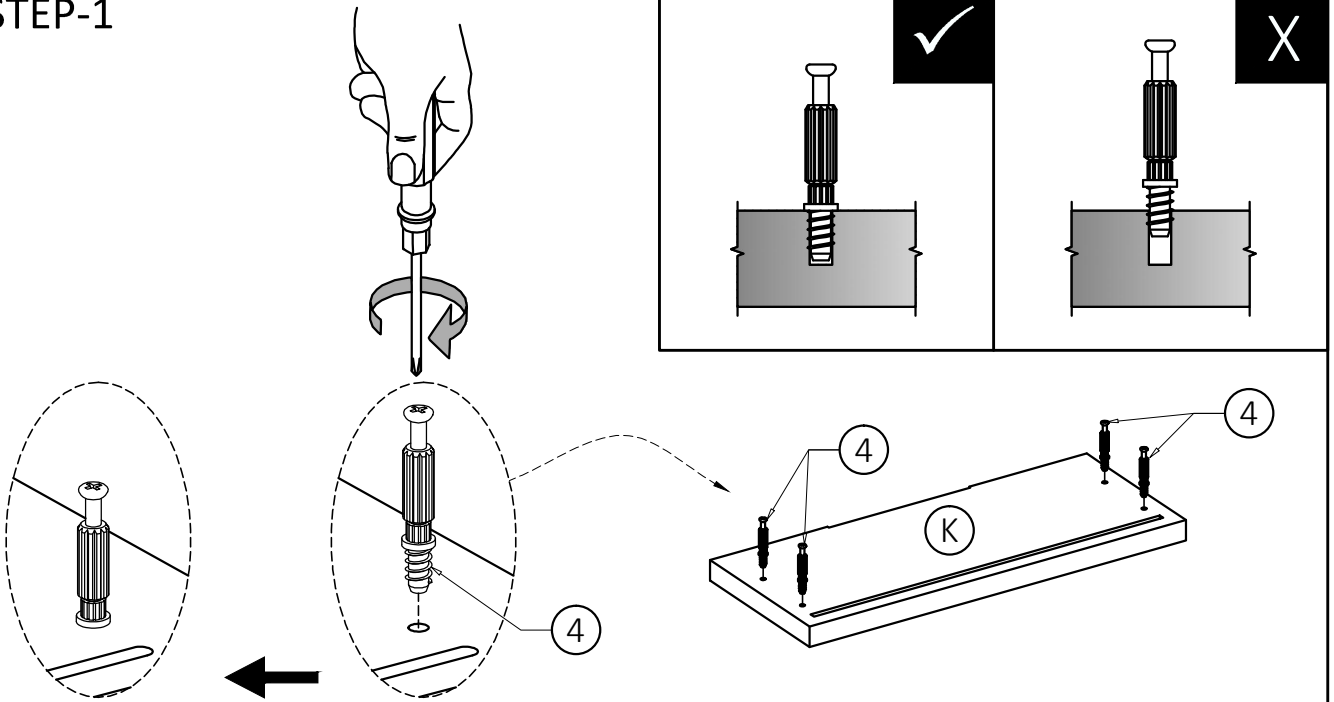

1. Attach four Cam Lock Pins (4) into pre-drilled holes at back of Drawer Front (K).
2. Use Phillips screwdriver to secure Cam Lock Pins. Do not over-tighten.

STEP-2

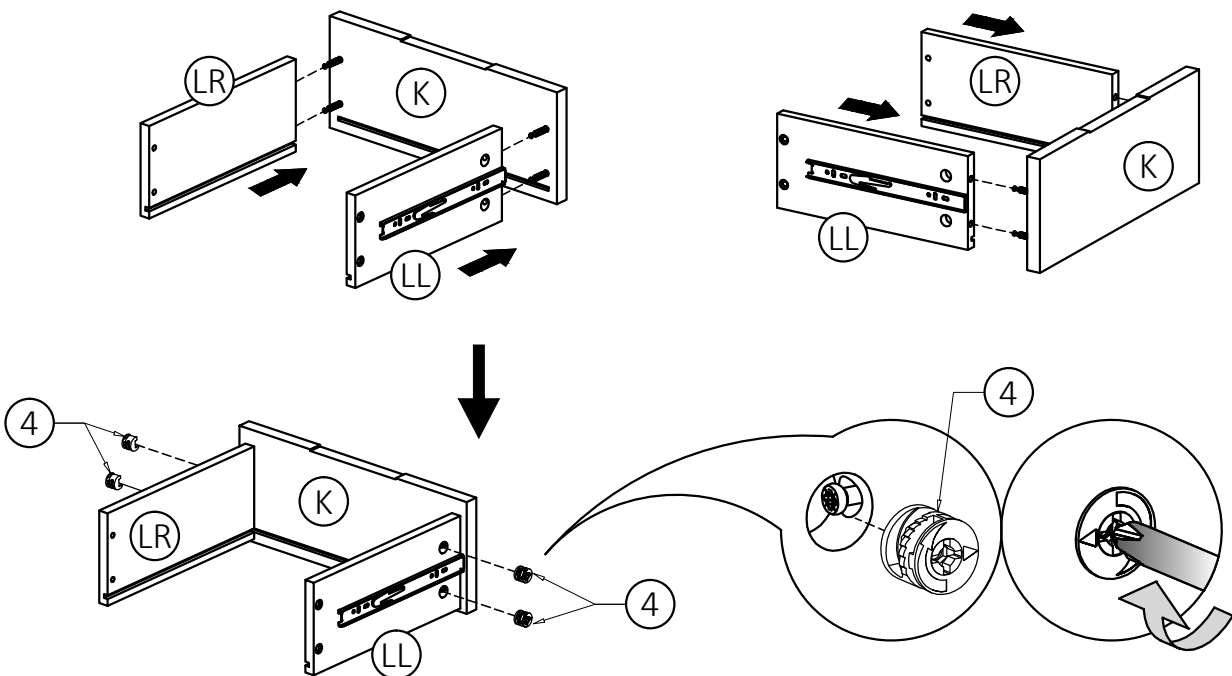

1. Align Cam Lock Pins with guide holes and attach Drawer Sides (LL, LR) to Drawer Front (K).
2. Insert two Cam Locks (4) into guide holes on each Drawer Side (LL, LR).
3. Use Phillips screwdriver to secure Cam Locks. Do not over-tighten.

STEP-3

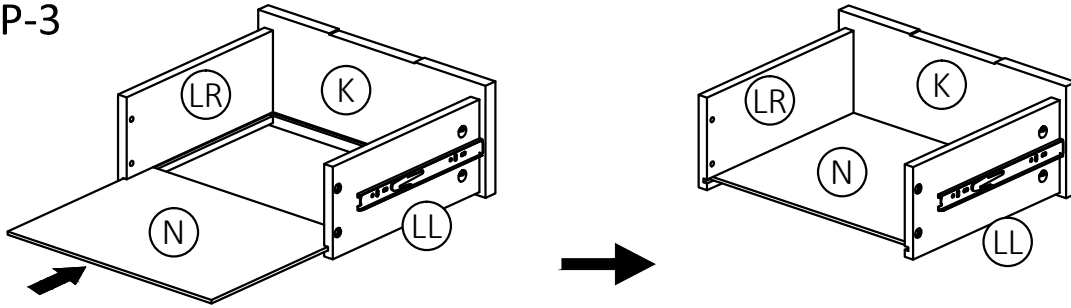

1. Slide Drawer Bottom (N) firmly into slots on Drawer Sides (LL, LR) and Drawer Front (K).

STEP-4

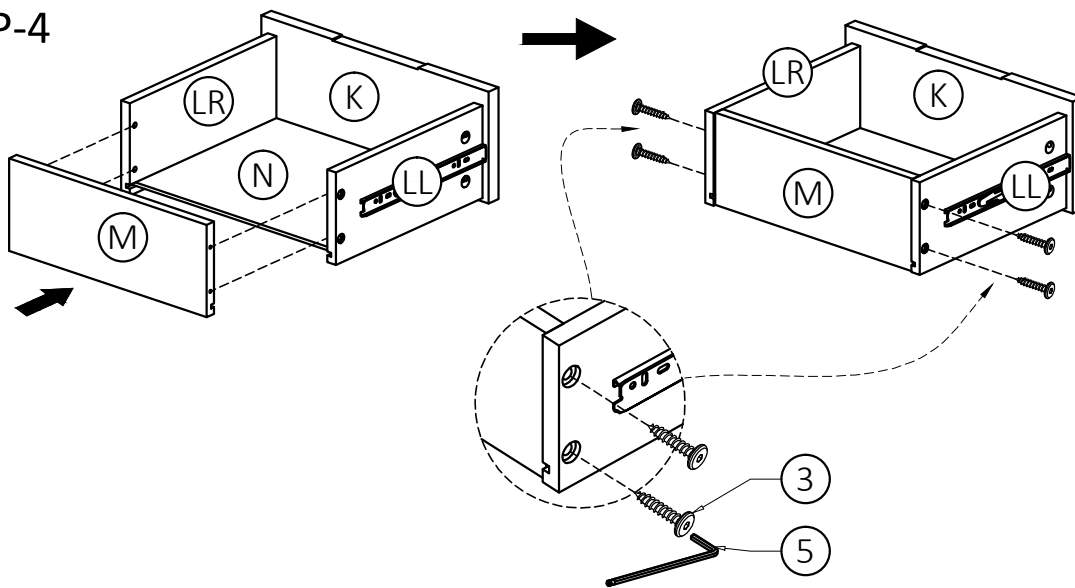

1. Align Drawer Back (M) with Drawer Bottom (N) and press firmly into slot .
2. Attach Drawer Back using two Allen Key Screws (3) through drilled holes on each Drawer Side (LL, LR).
3. Use Allen Key (5) to tighten Screws. Do not over-tighten

STEP-5

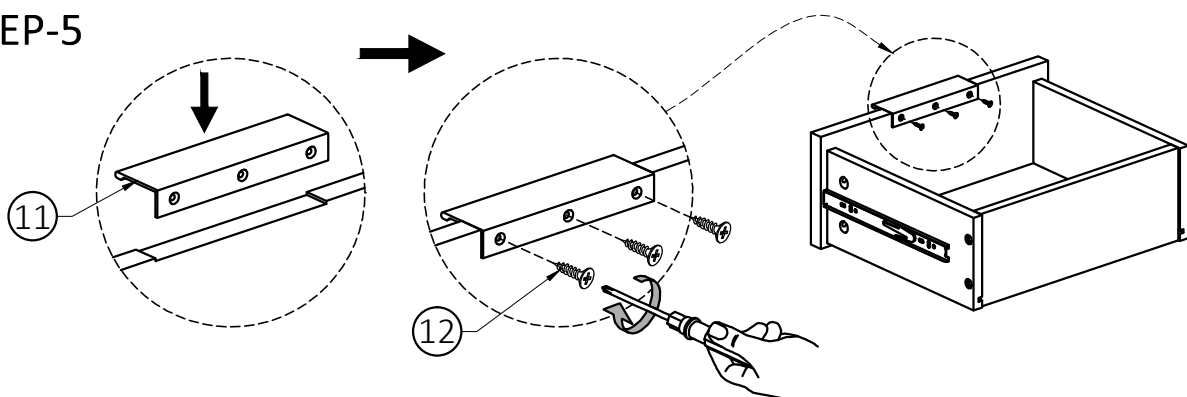

1. Use three Phillips Screws (12) to attach Handle (11) to Drawer Front .
2. Use Phillips screwdriver to snugly tighten Screws.

3. Repeat Step 1-5 for the other drawers.

STEP-6

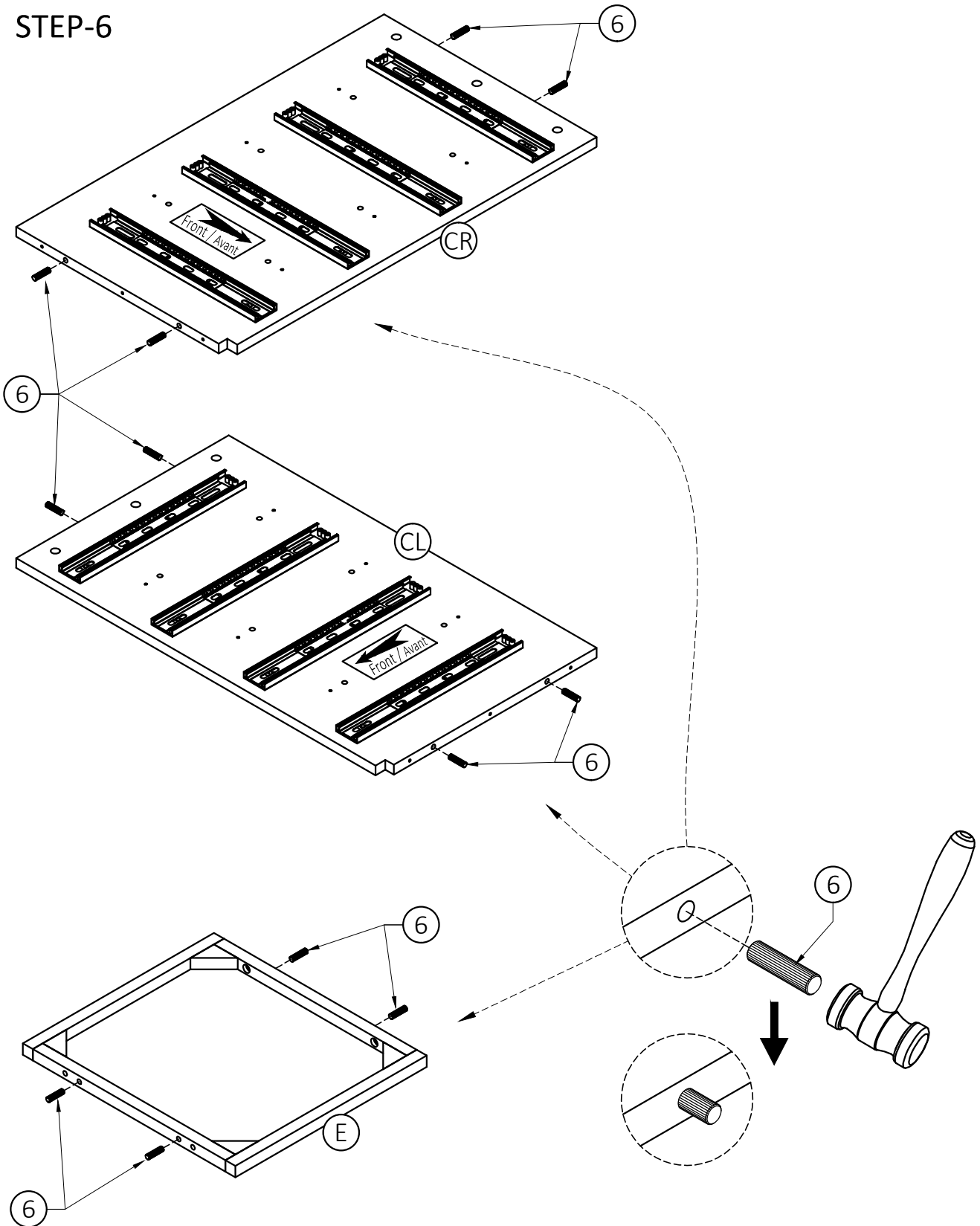

1. Insert four Wood Dowels (6) into guide holes on each Middle Frame (E).
2. Insert four Wood Dowels (6) into guide holes on each Divider (CL, CR).
3. Use rubber mallet to tap Dowels (6) into bottom of holes securely. 1/2 length of Dowels should be exposed.

STEP-7

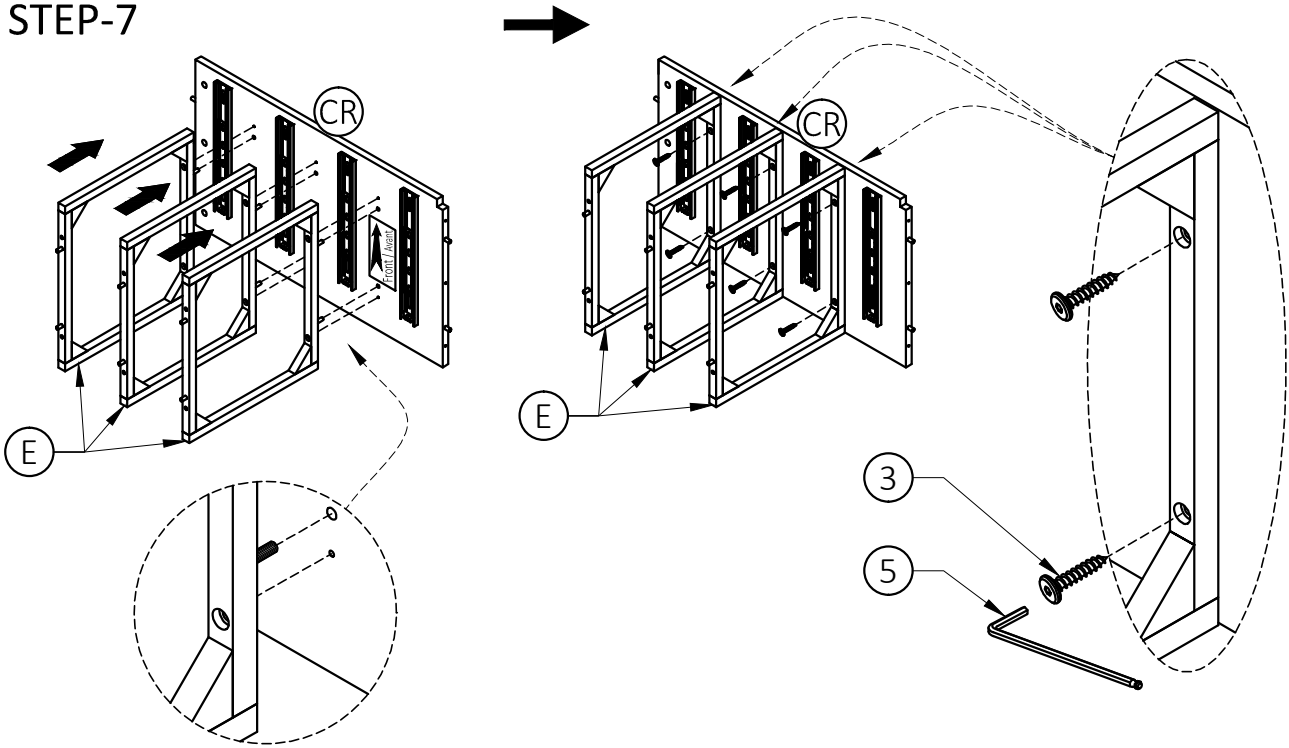

1. Align Wood Dowels with guide holes and attach Middle Frames (E) to Right Divider (CR).
2. Use two Allen Key Screws (3) to attach each Middle Frame (E) through guide holes to pre-drilled holes of Right Divider (CR).
3. Use Allen Key (5) to tighten Bolts. Do not over-tighten.

STEP-8

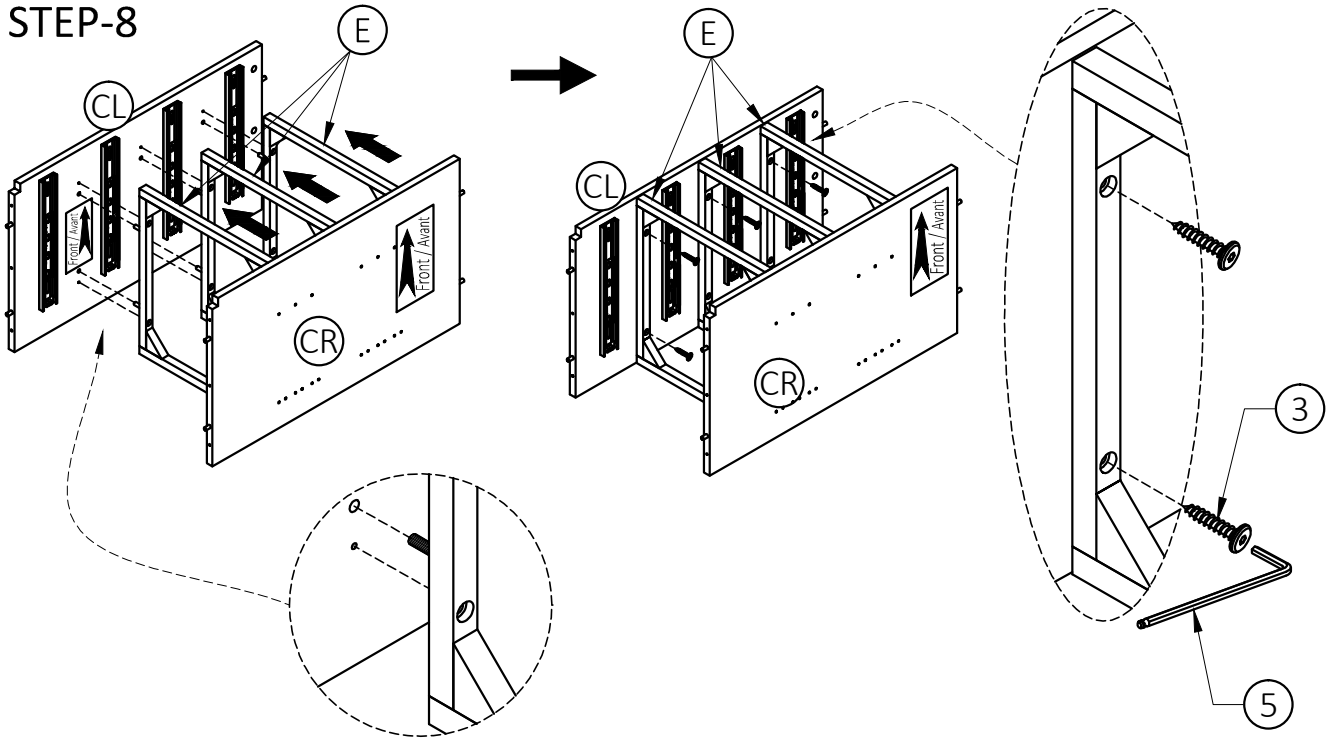

1. Repeat Step-7 for the Left Divider (CL).

STEP-9

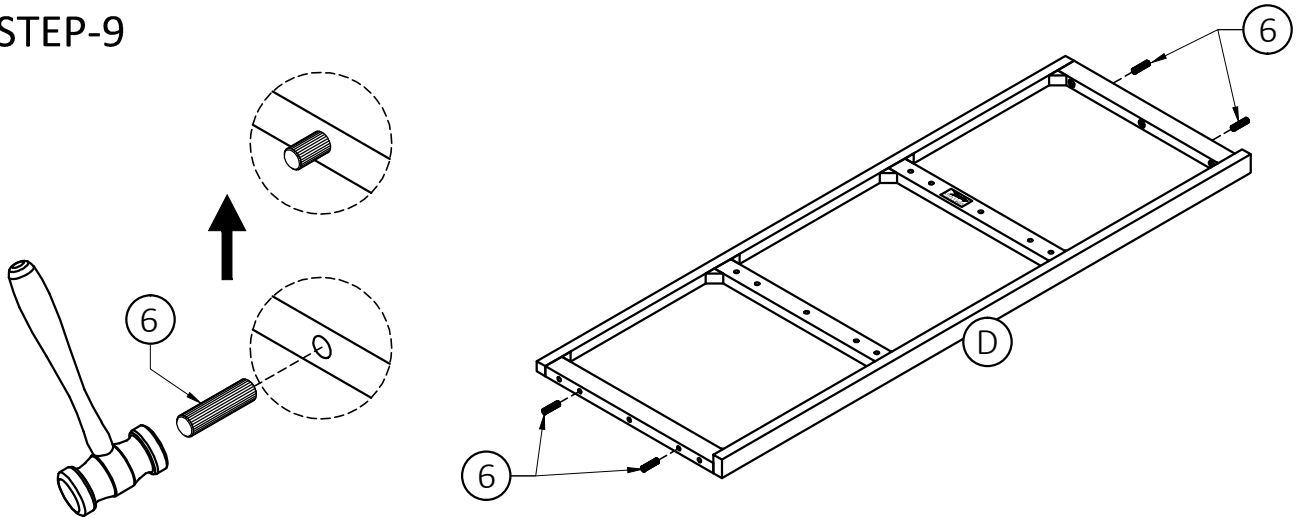

1. Insert four Wood Dowels (6) into guide holes on Bottom Frame (D).
2. Use rubber mallet to tap Dowels (6) into bottom of holes securely. 1/2 length of Dowels should be exposed.

STEP-10

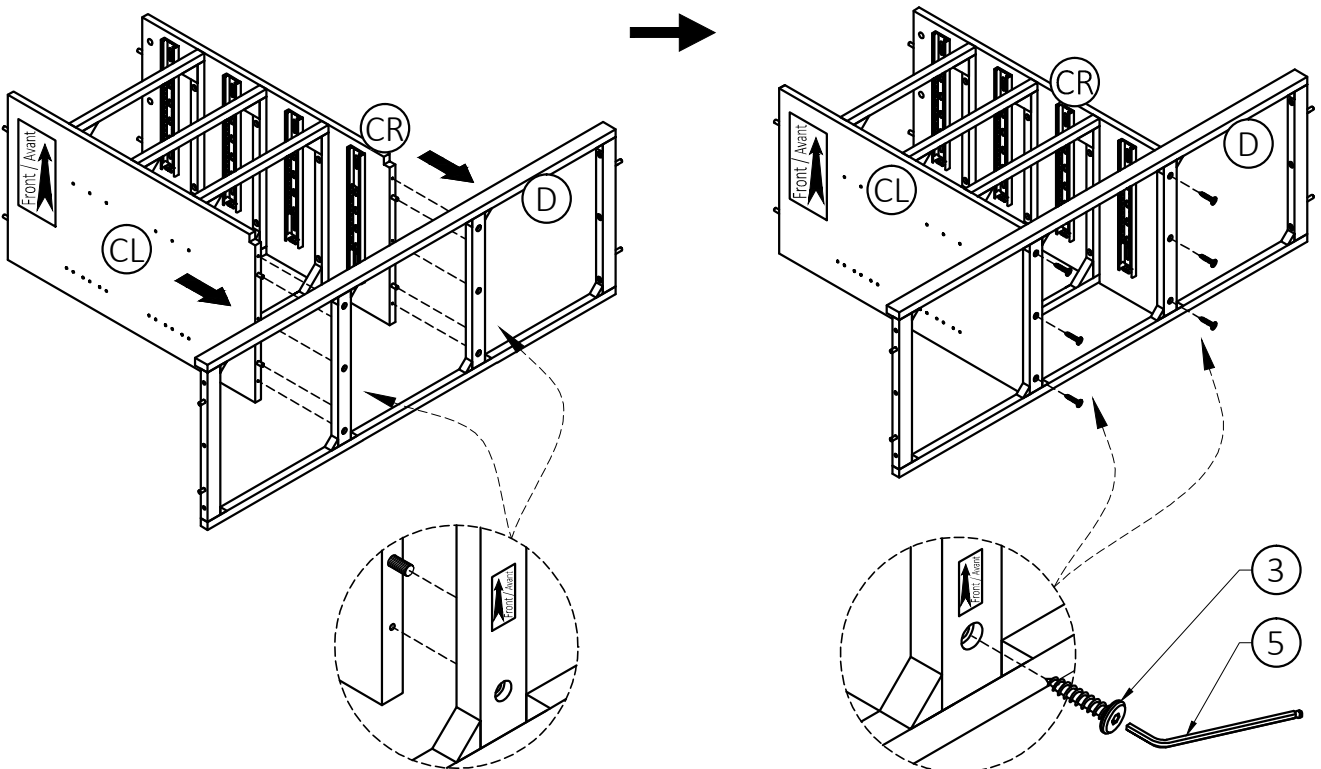

1. Align Wood Dowels with guide holes and attach Bottom Frame (D) to Divider (CL), (CR).
2. Use three Allen Key Screws (3) to attach Bottom Frame (D) through guide holes from Bottom Frame (D) to pre-drilled holes of each Divider (CL), (CR).
3. Use Allen Key (5) to tighten Screws. Do not over-tighten.

STEP-11

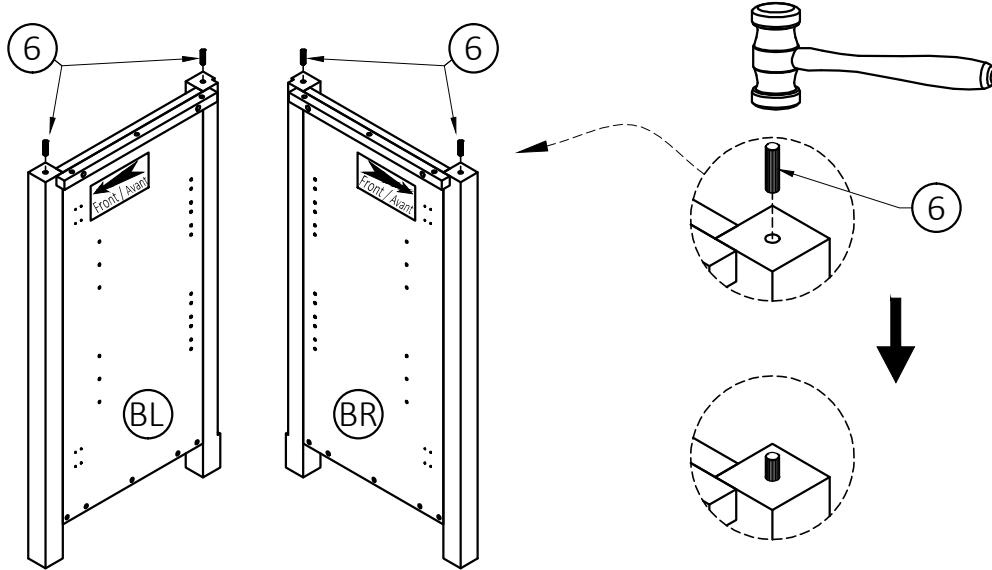

1. Insert two Wood Dowels (6) into guide holes on each Leg (BL), (BR).
2. Use rubber mallet to tap Dowels (6) into bottom of holes securely. 1/2 length of Dowels should be exposed.

STEP-12

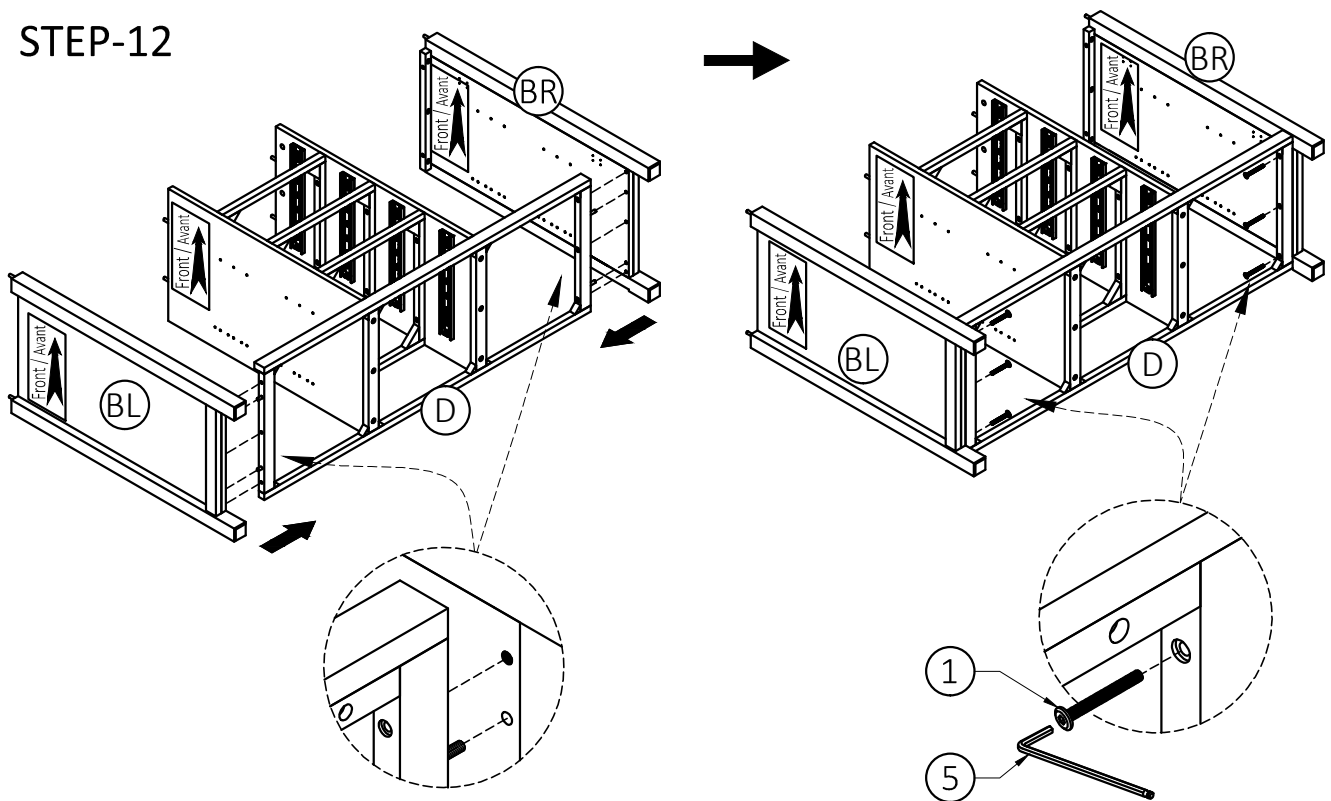

1. Align Wood Dowels with guide holes on Side (BL), (BR) and attach Sides (BL), (BR) to Bottom Frame (D).
2. Use six Allen Key Bolts (1) to attach Bottom Frame (D) through guide holes from Bottom Frame (D) to each Side (BL), (BR).
3. Use Allen Key (5) to tighten Screws. Do not over-tighten.

STEP-13

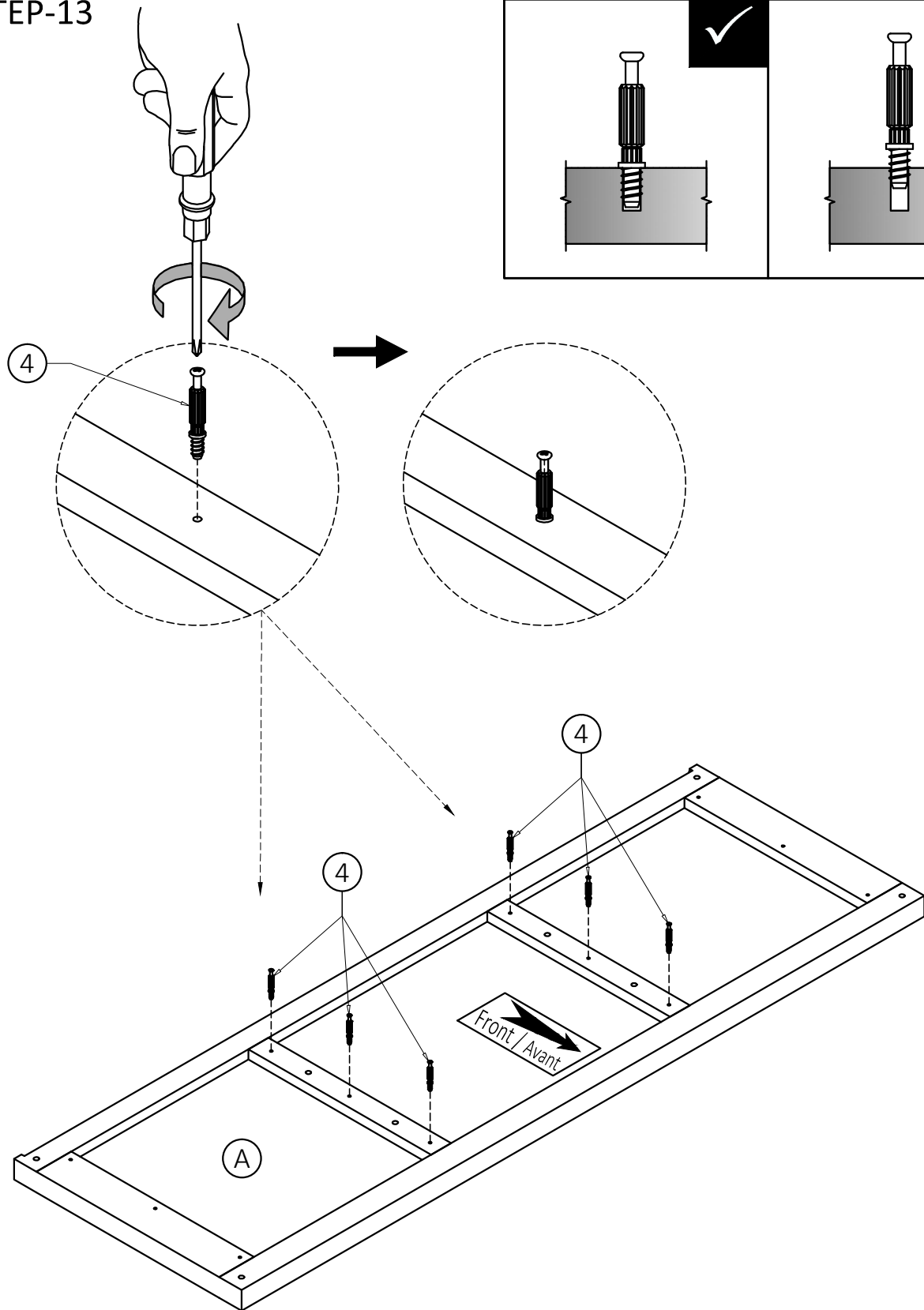

1. Attach six Cam Lock Pins (4) into pre-drilled holes at back of Top (A).
2. Use Phillips screwdriver to secure Cam Lock Pins. Do not over-tighten.

STEP-14

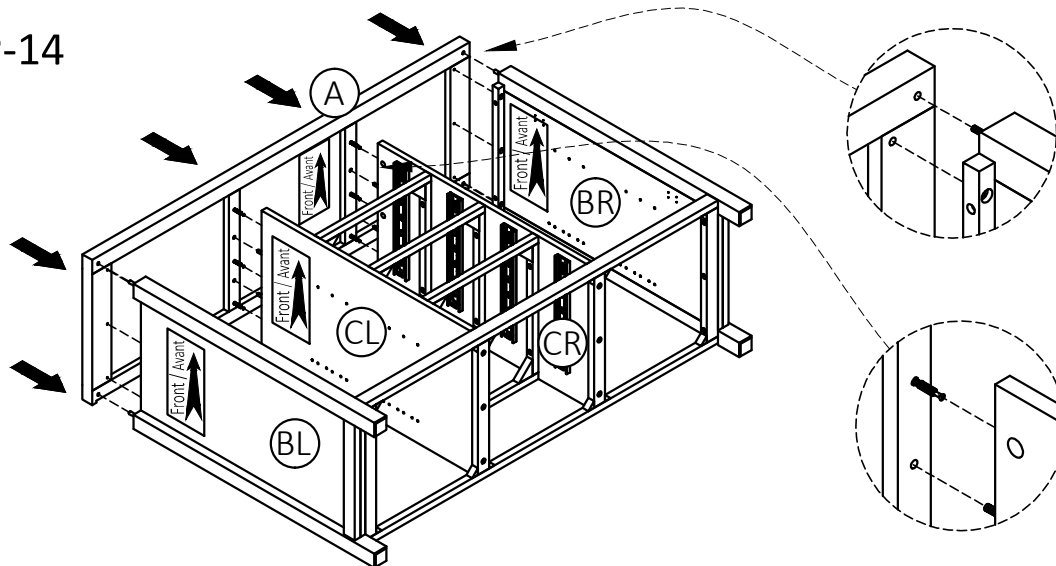

1. Align Wood Dowels with guide holes on Top (A) and attach Top (A).

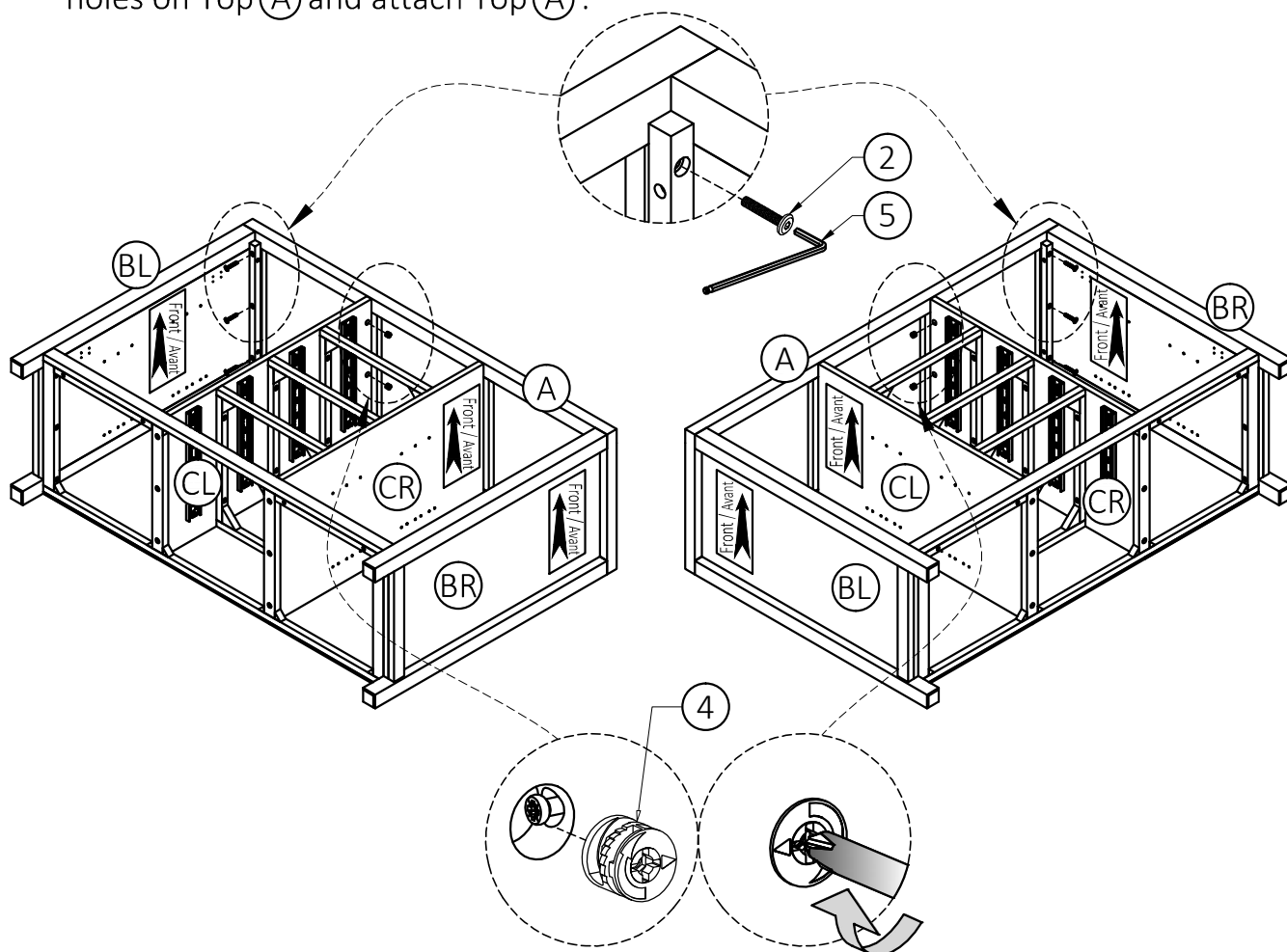

2. Insert three Cam Locks (4) into guide holes on each each Divider (CL), (CR). Use Phillips screwdriver to secure Cam Locks.
3. Use three Allen Bolts (2) to attach each Sides (BL), (BR) through guide holes to Top (A).
4. Use Allen Key (5) to tighten Screws and Bolts. Do not over-tighten.

STEP-15

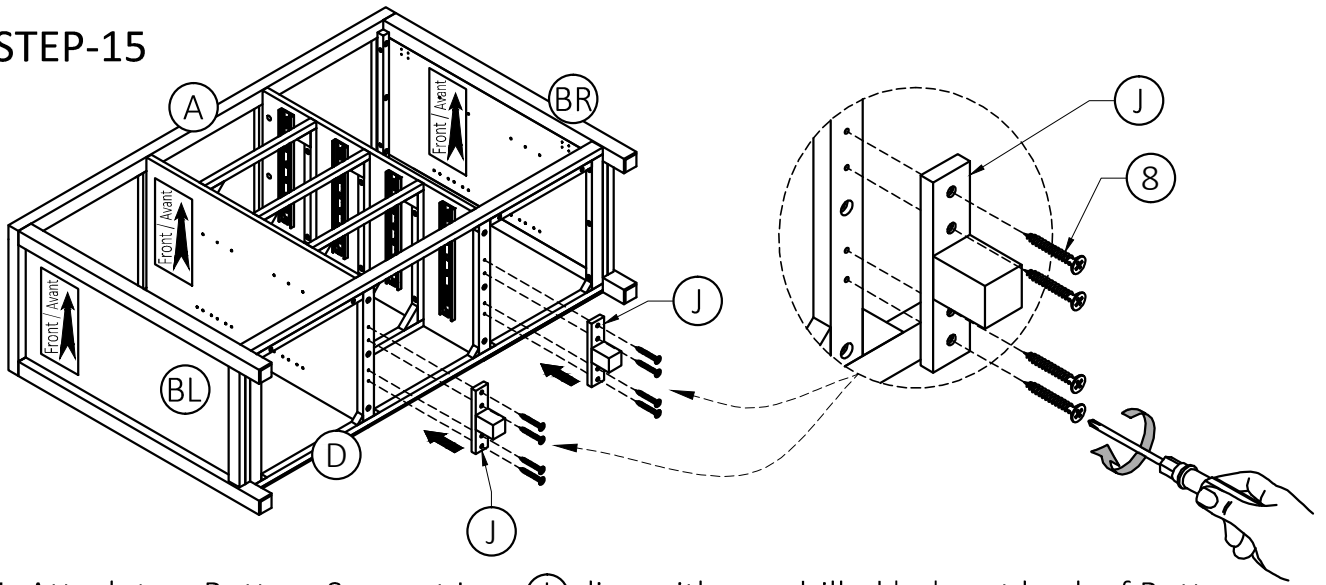

1. Attach two Bottom Support Legs (J) align with pre-drilled holes at back of Bottom Frame (D). Use Phillips Screwdriver to tighten four Phillips Screws (8).

STEP-16

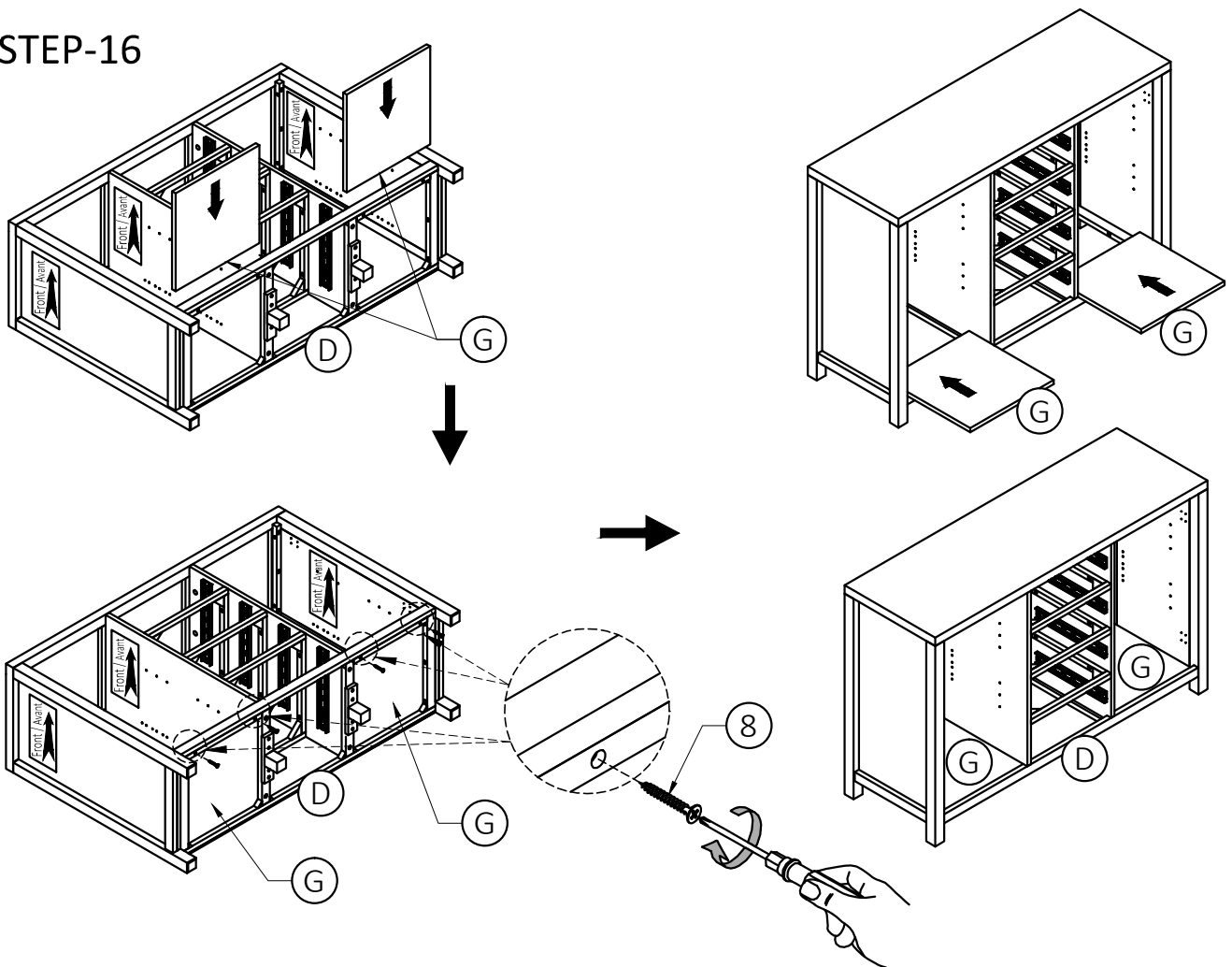

1. Use four Phillips Screws (8) to attach Bottom Frame (D) through guide holes to each Bottom Shelf (G).
2. Use Phillips Screwdriver to tighten four Phillips Screws (8).

STEP-17

Note:

The back of the cabinet frame does not have pre-drilled holes to attach the back panels.

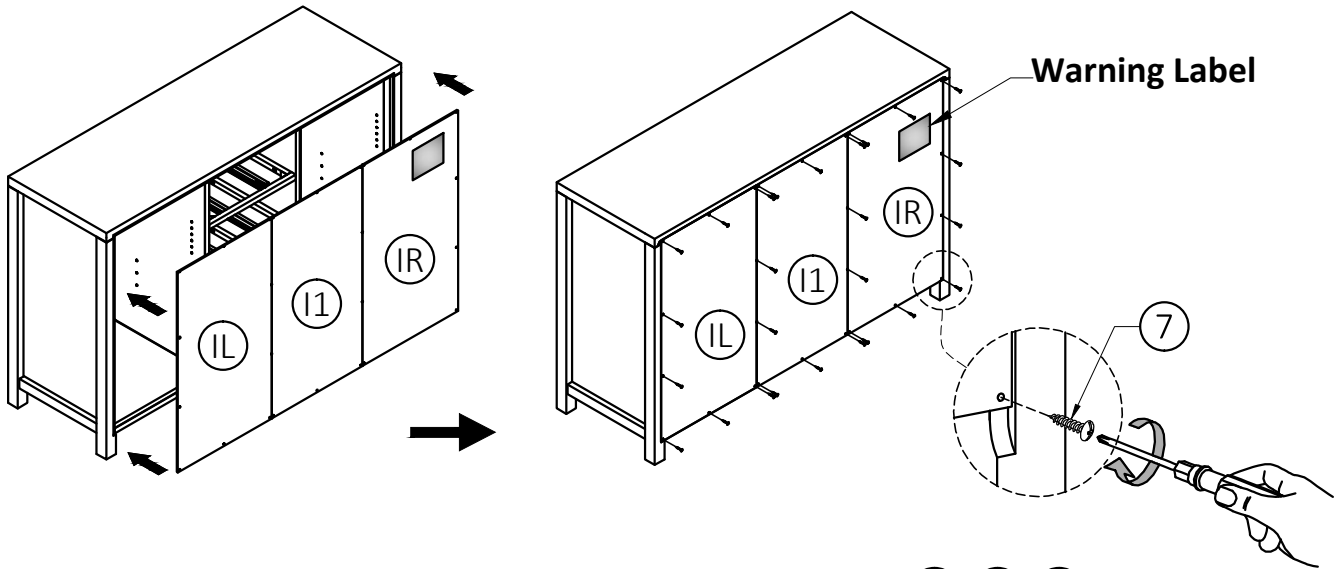

1. Use Phillips Screws Round Head (7) to attach Back Panels (IL), (IR), (I1) through guide holes to the back of Sideboard.
2. Use Phillips Screwdriver to tighten screws. Do not over-tighten.

STEP-18

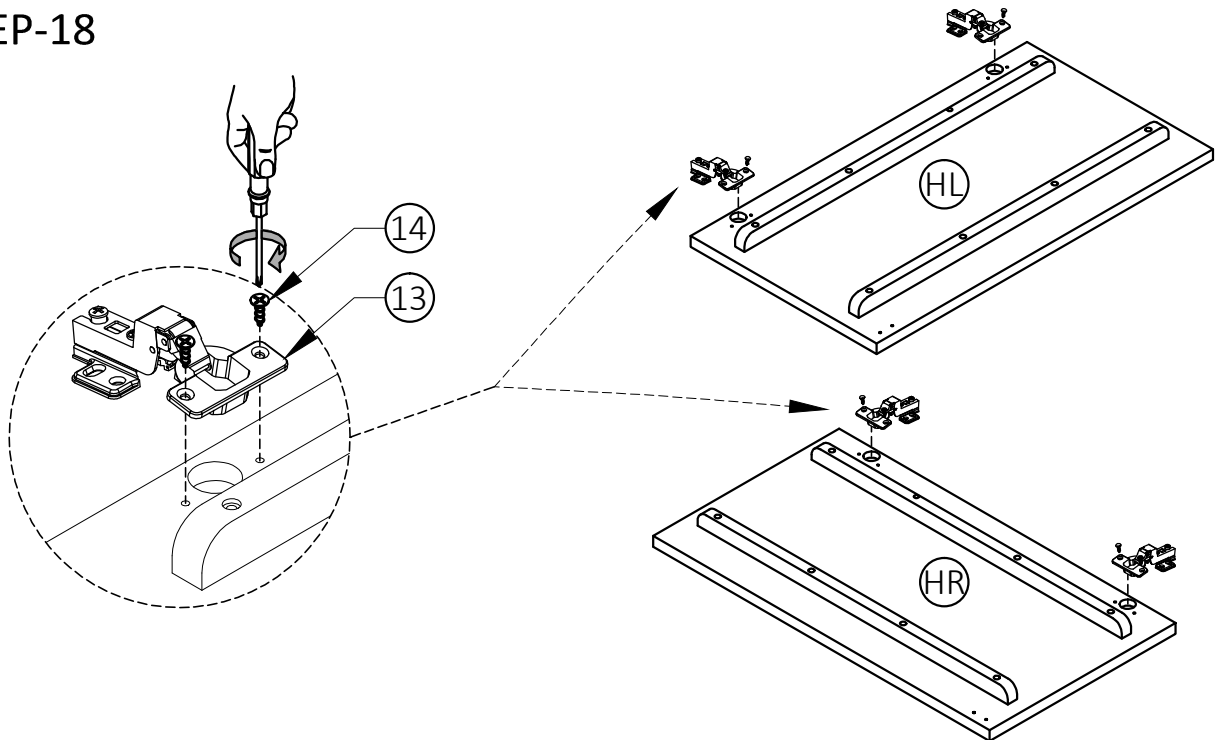

1. Attach Adjustable Hinges (13) to Doors (HL), (HR) using Phillips Screws (14) into pre-drilled holes on Doors (HL), (HR).

STEP-19

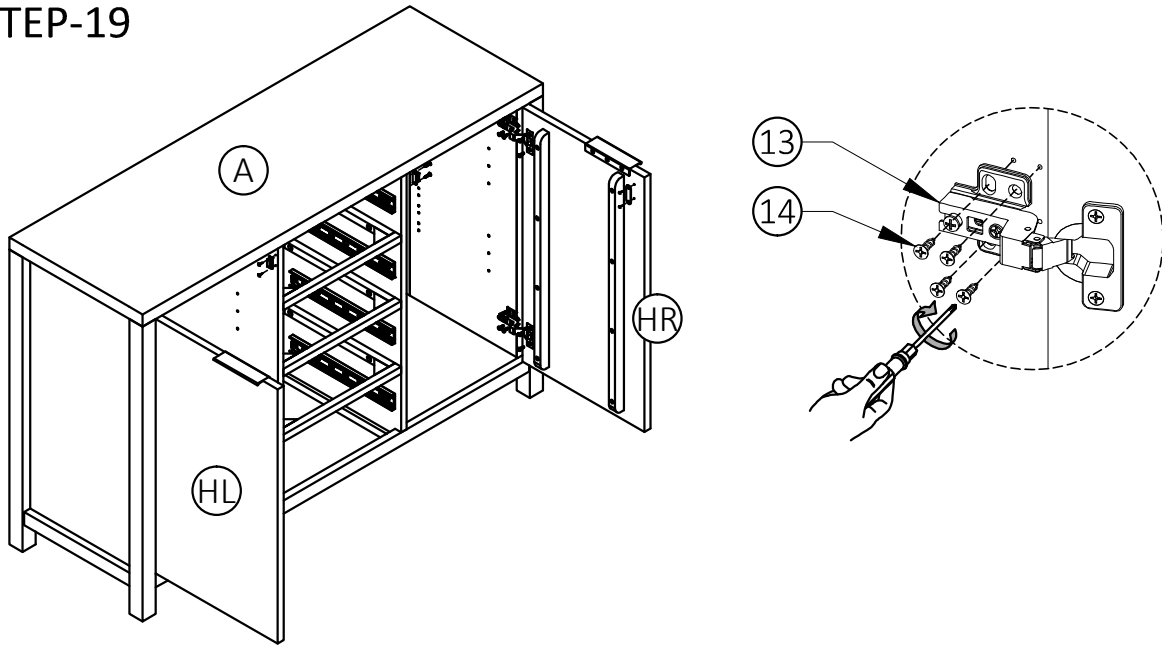

1. Attach Adjustable Hinges (13) on Doors (HL), (HR) to Sides (BL), (BR) using Phillips Screws (14) into guide holes on Sides (BL), (BR).
2. Use Phillips screwdriver to snugly tighten screws.

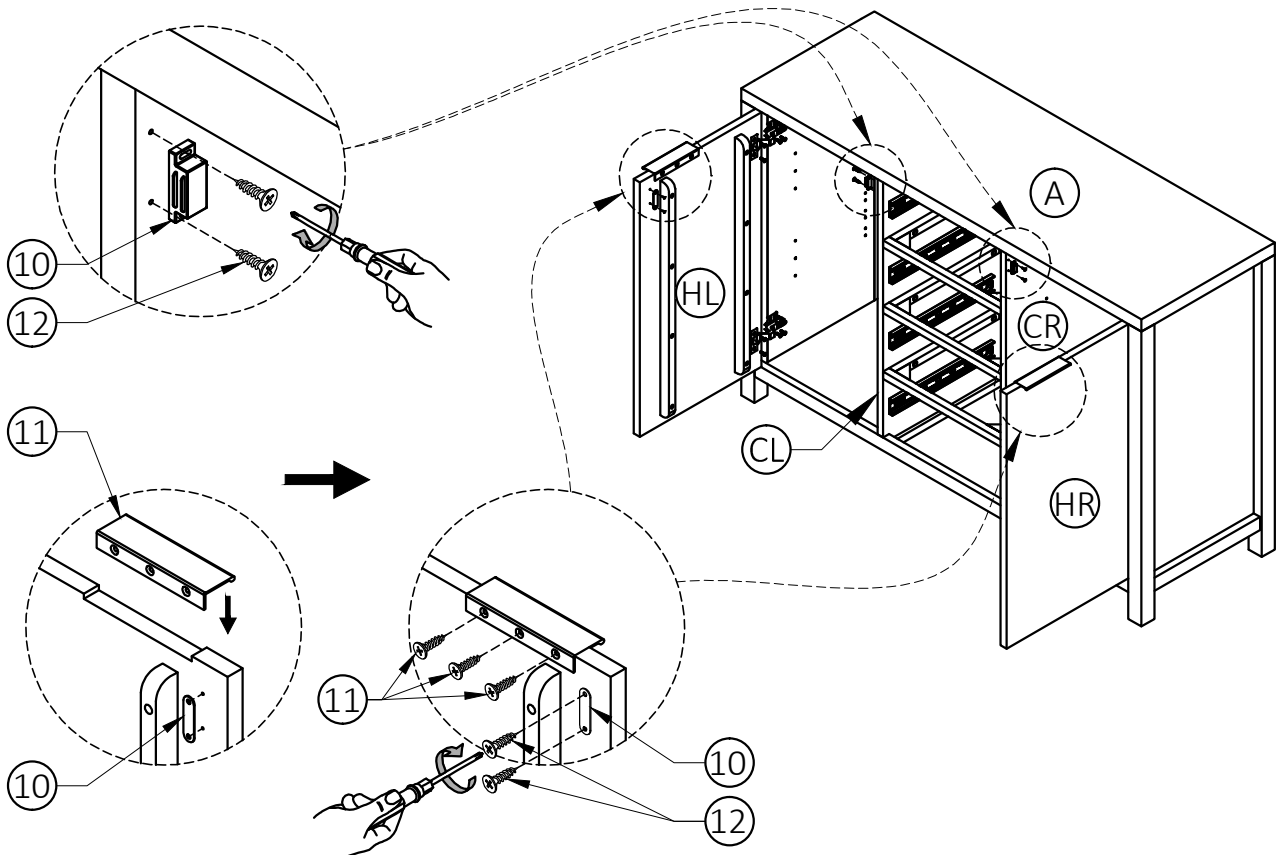

2. Use three Phillips Screws (12) to attach Handles (11) to Door (HL), (HR).
3. Attach Magnet Plates (10) to top corner of Doors (DL), (DR) using Phillips Screws (12) into pre-drilled holes on Doors (DL), (DR).
4. Attach Magnets (10) using Phillips Screws (12) into pre-drilled holes on Dividers (CL), (CR).
5. Use Phillips screwdriver to snugly tighten screw.

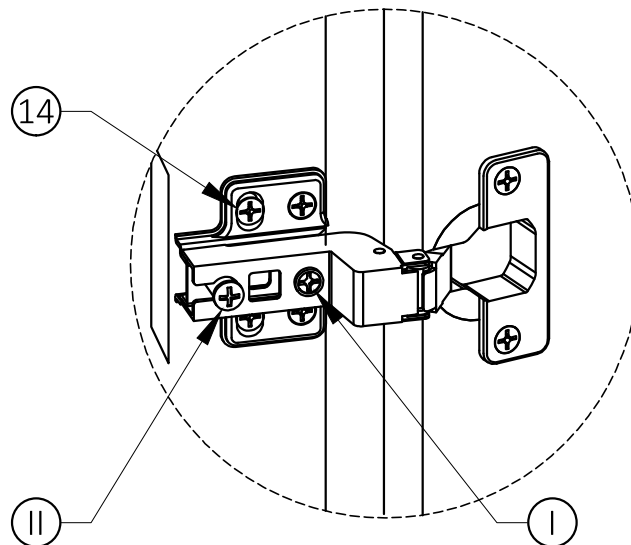
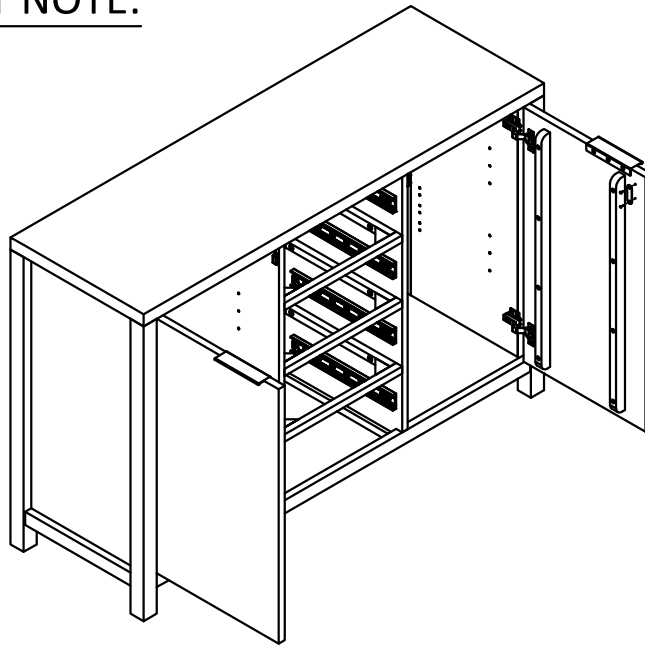
IMPORTANT NOTE:

Tighten the Screw marked ② to fasten hinge. The door may need to be adjusted so that all the spaces between the door and the unit sides are equal. To adjust, follow instructions:

1. Side adjustment 4 mm
To move the door towards the side panel, loosen screw ① and tighten screw ②.
To move the door away from the side panel, loosen screw ② and tighten screw ①.
2. Depth adjustment 4 mm
Loosen screw ② (just one turn), adjust door to desired position, re-tighten screw .
3. Height adjustment
Loosen screw ⑭ , adjust door to desired position, re-tighten screw .

STEP-20

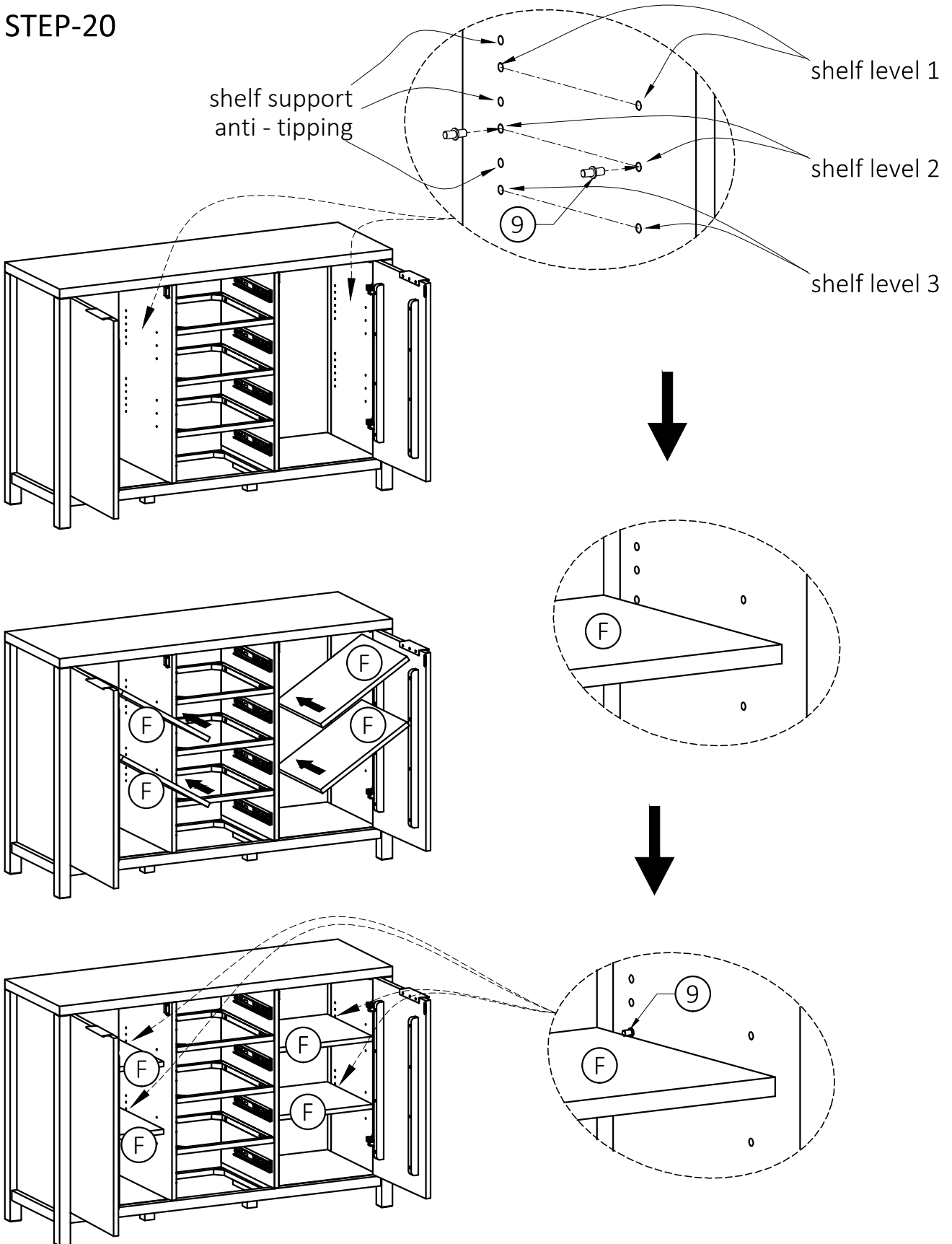

1. Use four Shelf Supports (9) for each Shelf (F) in desired location .
2. Two Shelf Supports (9) may be used on back top of each Shelf (F) as a tipping restraint.

STEP-21

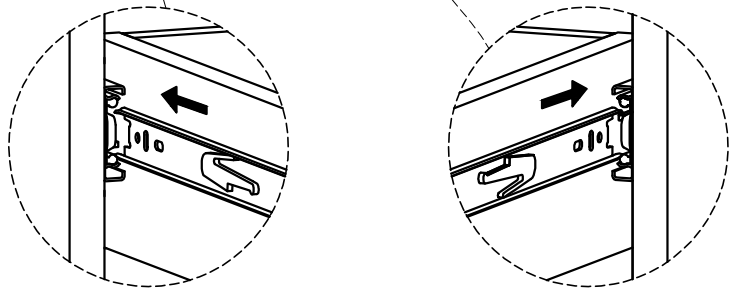
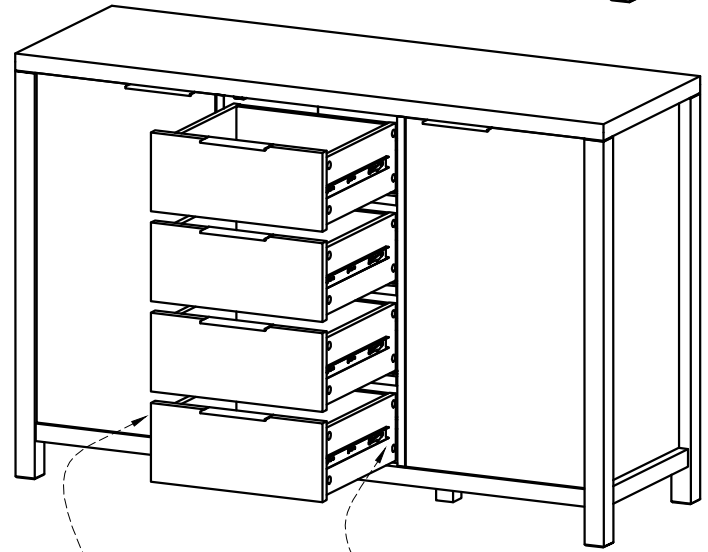
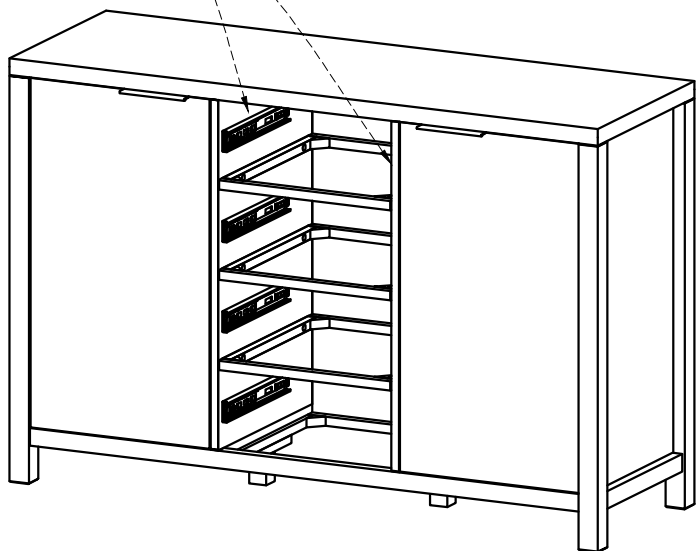
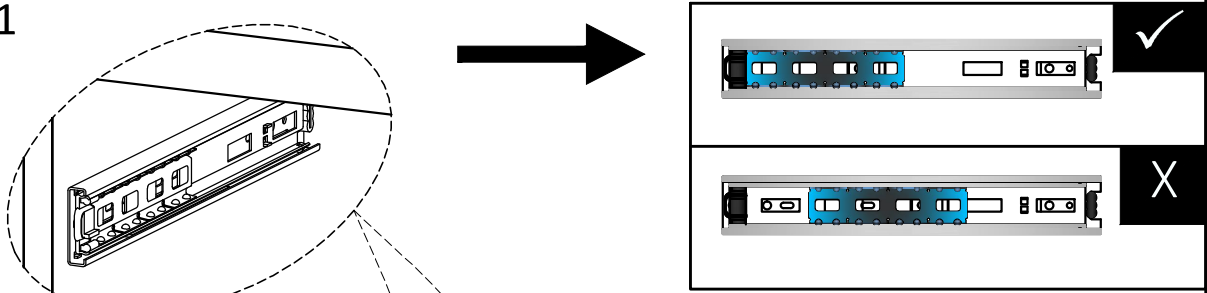

1. Insert assembled drawers into glides on assembled Sideboard.

FURNITURE TIP OVER RESTRAINT ASSEMBLY

WARNING

Serious or fatal crushing injuries can occur from furniture tip-over.
If the furniture tip over restraint kit is not in the box, please contact our customer service department in order to obtain another kit before using the furniture.

STEP-22

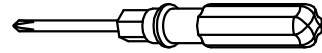

NOTE: The screwdriver is not included in the hardware pack.

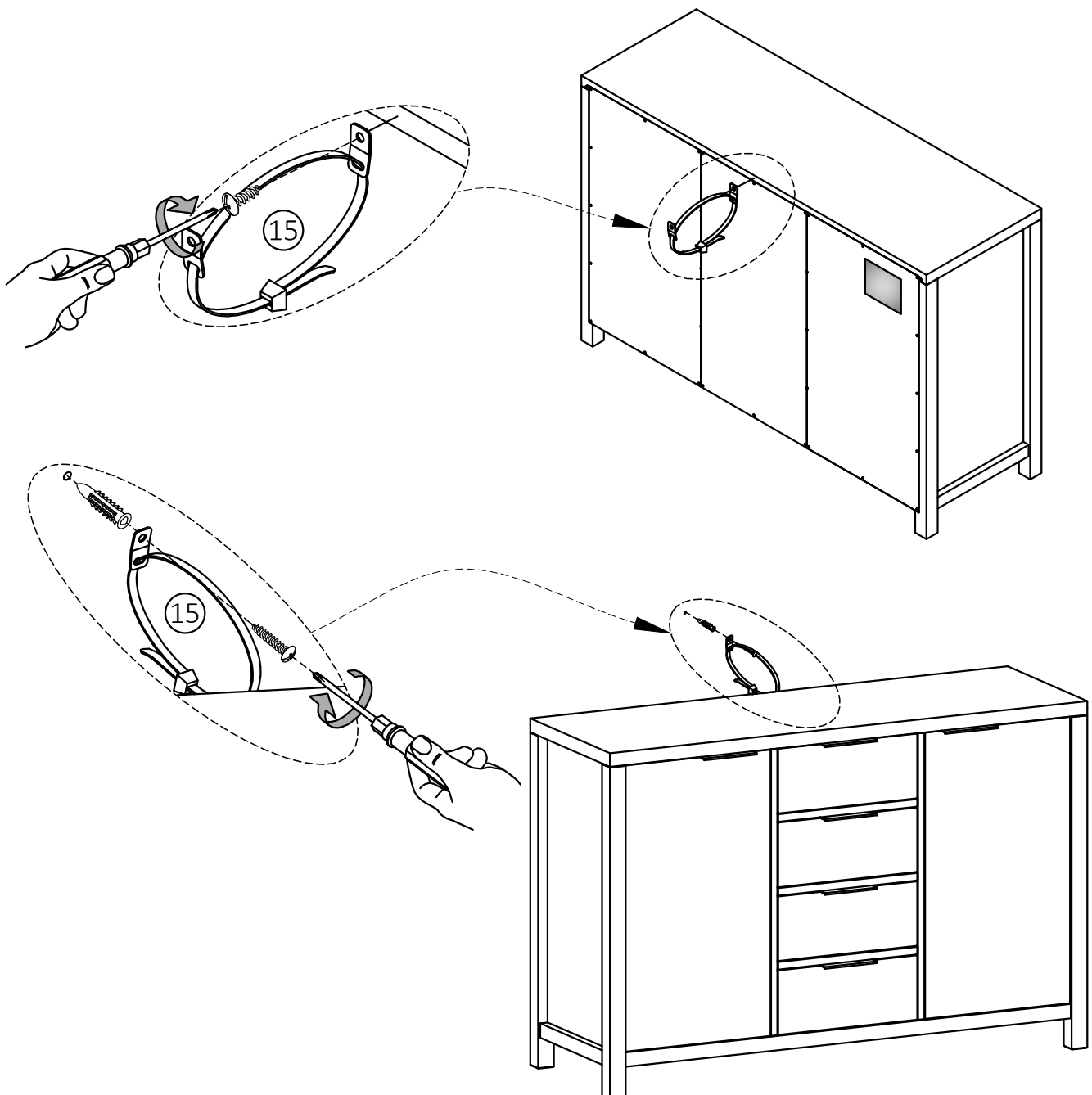

FURNITURE TIP OVER RESTRAINT ASSEMBLY

Furniture Tip Over Restraint Instructions:

1. Attach one of the mounting brackets securely to the back edge of the furniture. Use the shorter screw.

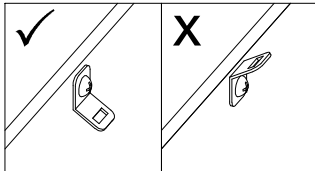

2. Determine where furniture is to be placed and mark location on the wall for mounting bracket screw hole approximately 2 inches **below** the bracket mounted to the furniture.

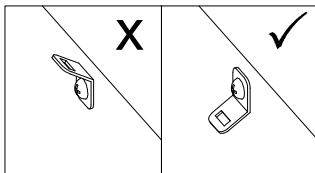

3. Drill a 3/16 inch hole in the wall. Press the plastic anchor into the hole and gently tap until the flange on the anchor is against the wall surface.
4. Position the bracket over the anchor and use the longer screw to securely attach the bracket to the wall.
5. Place the furniture so the back edge is in line with the bracket on the wall.
6. Lace an end of the nylon zip-tie strap down through each bracket. Bring both ends together and slide the smooth side upright through the square-shaped end and pull through to create the "locked" position.
7. Check to make sure the strap is securely laced and locked to the brackets.

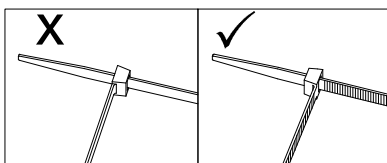

- **DO NOT** put a TV or other heavy objects on top of a chest of drawers or any other furniture not intended for use with a TV
- **DO NOT** place heavy objects in top drawers
- **DO NOT** let children climb or hang on drawers, doors or shelves



WARRANTY

Thank you for purchasing a Simpli Home – Wyndenhall – Brooklyn + Max product. These products have been made to demanding, high-quality standards and are guaranteed for domestic use against manufacturing faults for a period of 12 months from the date of purchase. This warranty does not affect your statutory rights.

In case of any malfunction of your product (failure, missing parts, etc.) please contact us at our toll free service line at 1-866-518-0120 ext. 262 from 9 am to 4 pm, Monday to Friday, Eastern Standard Time or by email at customerservice@simpli-home.com.

We reserve the right to repair or replace the defective product, at its discretion.

This product is guaranteed for 12 months if used for normal purposes. Any warranty is invalid if the product has been overloaded or subject to neglect, improper use or an attempted repair by other than an authorized agent. Heavy-duty or daily professional/commercial usage are not guaranteed.

Due to continuous product improvement, we reserve the right to change the product specifications without prior notice.