

USE AND CARE GUIDE

SPRING LAKE 5PC DINING SET W/ UPHOLSTERED CHAIRS-CHAIR

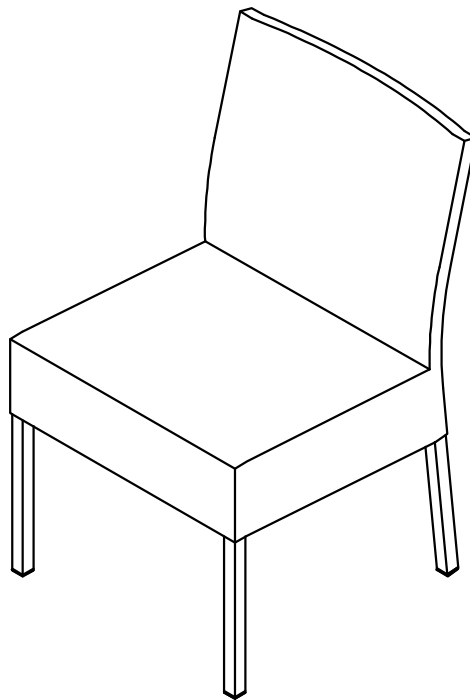

Questions, problems, missing parts?
Before returning to the store, call StyleWell Customer Service
8 a.m. - 7 p.m., EST, Monday - Friday, 9 a.m. - 6 p.m., EST, Saturday

1-877-527-0313

HOMEDEPOT.COM

THANK YOU

We appreciate the trust and confidence you have placed in StyleWell through the purchase of this dining chair. We strive to continually create quality products designed to enhance your home. Visit us online to see our full line of products available for your home improvement needs. Thank you for choosing StyleWell!!

Table of Contents

Table of Contents	2	Pre-Assembly.....	3
Important Safety Instructions.....	2	Planning Assembly	3
Warranty	2	Hardware Included	3
What is Covered.....	2	Package Contents	3
What is not Covered	2	Assembly	4
		Care and Cleaning	5

Important Safety Instructions

SAVE THESE INSTRUCTIONS

READ ALL INSTRUCTIONS BEFORE USE

To reduce the risk of injury to persons:

1. Close supervision is necessary when this furnishing is used by or near children, or disabled persons, if applicable.
2. Use this furnishing only for its intended use as described in these instructions. Do not use attachments not recommended by the manufacturer.

Warranty

THIS IS A RESIDENTIAL WARRANTY ONLY AND DOES NOT APPLY TO COMMERCIAL USE

1 YEAR FRAME AND FABRIC LIMITED WARRANTY

WHAT IS COVERED

We warrant the frame and the fabric to be free of manufacturing defects to the original purchaser for one year.

WHAT IS NOT COVERED

It remains the customer's responsibility for freight and packaging charges to and from our service center. This warranty does not cover commercial use, hardware, acts of nature, fire, freezing, and abusive use. In addition, purchased parts are not covered under this warranty. We reserve the right to make substitutions with similar merchandise, if the model in question is no longer in production.

For a copy of our full limited warranty, please contact our customer service team below.
Contact the Customer Service Team at 1-877-527-0313 or visit www.homedepot.com.

Pre-Assembly

PLANNING ASSEMBLY

Please read this entire instruction manual prior to assembly.

Compare all parts packed in the carton against the parts list. Remove all protective materials and place the parts on a non-abrasive surface to avoid scratching.



NOTE: More than one person may be required to complete the assembly of this product.

HARDWARE INCLUDED



NOTE: Hardware not shown to actual size.



_AA



_BB

Part	Description	Quantity
AA	M6 x 20 mm Allen bolt	8
BB	M6 Allen Wrench	1

PACKAGE CONTENTS

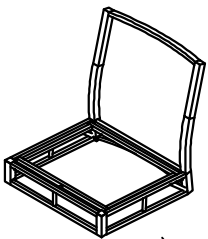

A



B



C

Part	Description	Quantity
A	Chair Frame	1
B	Front leg	2
C	Back leg	2

Assembly

1 Attaching the legs to the chair frame

- Place the chair frame upside down on a soft, flat, non-abrasive surface.
- Attach the 4 legs (B) and (C) to the chair frame (A) with M6 x 20 mm bolts (AA) using the M6 Allen wrench (BB).
- Once all of the bolts are in place, fully tighten all the bolts.

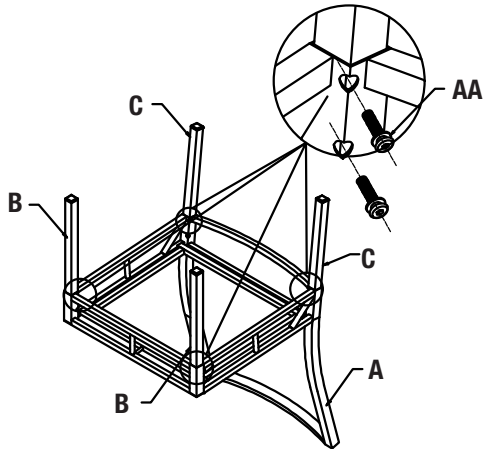

2 Positioning the chair

- Turn over the chair and set it down on its legs.
- The chair is now ready for use.

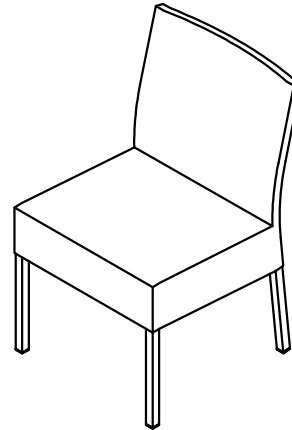

Care and Cleaning

- Do not allow water to build up in the frames. This will cause corrosion and possible freezing damage in cold climates.
- Use a mild soap and water for normal cleaning. Do not use janitorial or alcohol based cleaners. Some cleaners may be marked as natural, but some ingredients may cause discoloration or have an adverse reaction to your finish.
- Rinse with clean water and dry with a soft, absorbent cloth towel.
- Treat the frames with a liquid wax for maximum protection against UV rays and/or salty, damp air.

StyleWell™

Questions, problems, missing parts?

Before returning to the store,
call StyleWell Customer Service

8 a.m. - 7 p.m., EST, Monday - Friday, 9 a.m. - 6 p.m., EST, Saturday

1-877-527-0313

HOMEDEPOT.COM

Retain this manual for future use.