



Climate 5000 Series 36K BTU Multi Zone Hyper Heat Outdoor Unit – Non Ducted

Engineering
Submittal
Sheet



BOSCH

Overview and Project Information	
  	Project Name
	Location
	Architect
	Engineer
	General Contractor
	Reference #
	Date

36K Btu Multi Zone Hyper Heat Outdoor Unit - Non Ducted		
Indoor model #	8733953094 (Qty 4)	
Indoor model name	BMS500-AAU009-1AHWXB (Qty 4)	
Outdoor model #	8733953121	
Outdoor model name	BMS500-AAM036-1CSXHB	
Performance Data		
Cooling	Capacity (Btu/h):	36000
	Input (W)	2667
	Rated current (A)	11.6
	EER (Btu/w)	13.5
	SEER (Btu/w)	21.5
Heating at 47°F	Capacity (Btu/h)	36000
	Input (W)	2777
	Rated current (A)	12.1
	COP (W/W)	3.8
	HSPF4	10.5
	HSPF5	8.5
Electrical Data		
Power supply (V / Ø / Hz)	208-230 / 1 / 60	
Min. Circuit ampacity (A)	35.0	
Max. Fuse (A)	50.0	
Compressor Data		
Type:	Twin-Rotary	
Refrigerant oil /oil charge (ml)	ESTER OIL VG74 / 1400	
Input (W)	3040	
Rated current (RLA / A)	21.00	
Operation Range		
ODU	Cooling (°F / °C)	-22~122 / -30~50
	Heating (°F / °C)	-22~86 / -30~30

Piping		
Refrigerant precharge (ft / m)	98 / 30	
Refrigerant charge (oz / g)	162.3 / 4601	
Additional charge per ft (oz)	0.161	
Liquid side (in / mm)	4 x 1/4" / Ø6.35	
Gas side (in / mm)	3 x 3/8" + 1 x 1/2" 3 x Ø9.52 + 1 x Ø12.7	
Max. refrigerant pipe length (ft / m)	262 / 80	
Max. length to one IDU (ft / m)	115 / 35	
Max. height difference between IDU and ODU (ft / m)	49 / 15	
Max. height difference between IDU's (ft / m)	33 / 10	
System Data		
Refrigerant Type	R410A	
Design pressure (PSIG)	550/340	
Dehumidification (pts/hr)	8.45	
ODU	Fan motor qty (ea)	2
	Fan motor input (W)	126.0
	Fan motor RLA (A)	1.18
	Fan motor speed, H / M / L (RPM)	800 / 700 / 600
	Air flow, Max (CFM)	4500
	Noise level, Max (dB(A))	64.0
IDU	Net weight (lbs / kg)	223.8 / 101.5
	Gross weight (lbs / kg)	255.1 / 115.7
IDU	Minimum # of indoors	2
	Maximum # of indoors	4

Climate 5000 Series

36K Btu Multi Zone Hyper Heat Outdoor Unit – Non Ducted



BOSCH

Outdoor Unit Dimensions and Connections

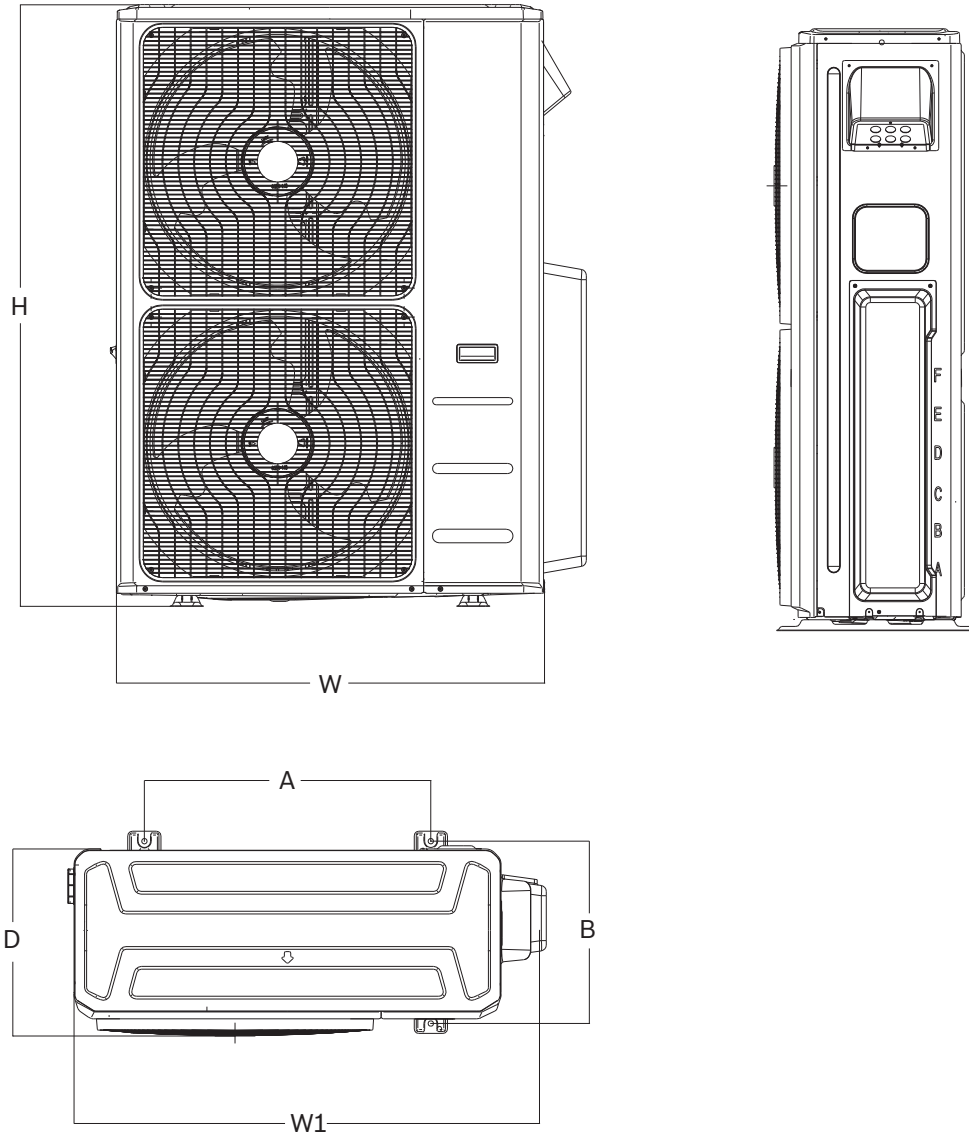

Model	W (in)	D (in)	H (in)	W1 (in)	A (in)	B (in)
BMS500-AAM036-1CSXHB	37.5	16.3	52.5	41.1	25.0	15.9