

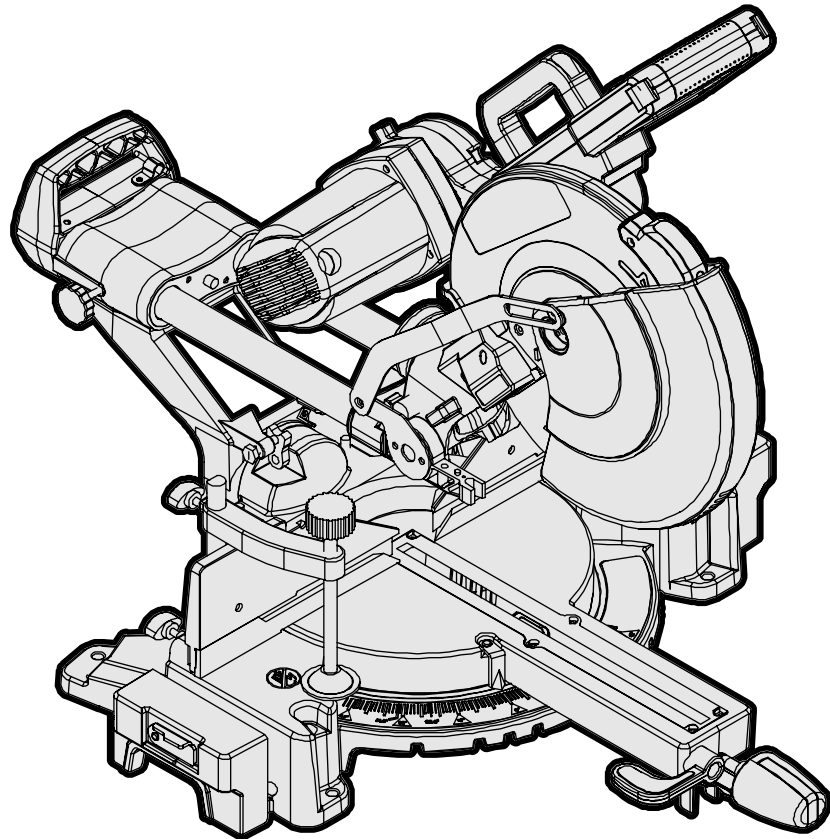

**MODEL MM1214, MM1214T**

# **12" DUAL-BEVEL MITER SAW**

**Instruction Manual**



## **NEED HELP? CONTACT US!**

Have product questions? Need technical support? Please feel free to contact us:



**1-800-232-1195 (M-F 8AM-5PM CST)**



**TECHSUPPORT@WENPRODUCTS.COM**

**IMPORTANT:** Your new tool has been engineered and manufactured to WEN's highest standards for dependability, ease of operation, and operator safety. When properly cared for, this product will supply you years of rugged, trouble-free performance. Pay close attention to the rules for safe operation, warnings, and cautions. If you use your tool properly and for its intended purpose, you will enjoy years of safe, reliable service.

For replacement parts and the most up-to-date instruction manuals, visit ***WENPRODUCTS.COM***

# CONTENTS

<b>WELCOME</b>	<b>3</b>
Introduction .....	3
Specifications.....	3
<b>SAFETY</b>	<b>4</b>
General Safety Rules .....	4
Miter Saw Safety Warnings.....	6
Electrical Information.....	8
<b>BEFORE OPERATING</b>	<b>9</b>
Unpacking & Transportation .....	9
Know Your Miter Saw .....	10
Assembly & Adjustments.....	12
<b>OPERATION &amp; MAINTENANCE</b>	<b>19</b>
Operation .....	19
Maintenance.....	21
Troubleshooting Guide.....	22
Exploded View & Parts List.....	23
Warranty Statement .....	27

To purchase accessories and replacement parts for your tool, visit ***WENPRODUCTS.COM***

**Replacement Miter Saw Blades** (Model MM1214B)  
**Replacement Carbon Brushes** (Model MM1214-114)

## INTRODUCTION

Thanks for purchasing the WEN Miter Saw. We know you are excited to put your tool to work, but first, please take a moment to read through the manual. Safe operation of this tool requires that you read and understand this operator's manual and all the labels affixed to the tool. This manual provides information regarding potential safety concerns, as well as helpful assembly and operating instructions for your tool.

 Indicates danger, warning, or caution. The safety symbols and the explanations with them deserve your careful attention and understanding. Always follow the safety precautions to reduce the risk of fire, electric shock or personal injury. However, please note that these instructions and warnings are not substitutes for proper accident prevention measures.

**NOTE:** The following safety information is not meant to cover all possible conditions and situations that may occur. WEN reserves the right to change this product and specifications at any time without prior notice.

At WEN, we are continuously improving our products. If you find that your tool does not exactly match this manual, please visit [wenproducts.com](http://wenproducts.com) for the most up-to-date manual or contact our customer service at **1-800-232-1195**.

**Keep this manual available to all users during the entire life of the tool and review it frequently to maximize safety for both yourself and others.**

## SPECIFICATIONS

Model Number	MM1214, MM1214T	
Motor	120V, 60 Hz, 15A	
Laser Type	650 nm, <1 mW	
Laser Class	II	
No-Load Speed	3800 RPM	
Blade Part Number	MM1214B	
Blade Size	12" (305mm) TCT	
Arbor Size	1" (25.4mm)	
Kerf	2.8mm	
Teeth	60T	
Miter Table Angles	0° - 45° Left & Right	
Bevel Cut Angles	0° - 45° Left & Right	
Positive Miter Stops	0°, 15°, 22.5°, 30°, and 45° Left & Right	
Cutting Capacity	0° Miter, 90° Bevel	3-1/2" x 13-3/8"
	45° Miter, 90° Bevel	3-1/2" x 9-1/2"
	0° Miter, 45° Bevel	2-1/8" x 13-3/8"
	45° Miter, 45° Bevel	2-1/8" x 9-1/2"
Weight	61 Pounds	
Product Dimensions	27 in. x 35 in. x 20 in.	

# GENERAL SAFETY RULES

 **WARNING!** Read all safety warnings and all instructions. Failure to follow the warnings and instructions may result in electric shock, fire and/or serious injury.

Safety is a combination of common sense, staying alert and knowing how your item works. The term “power tool” in the warnings refers to your mains-operated (corded) power tool or battery-operated (cordless) power tool.

## SAVE THESE SAFETY INSTRUCTIONS.

### WORK AREA SAFETY

- 1. Keep work area clean and well lit.** Cluttered or dark areas invite accidents.
- 2. Do not operate power tools in explosive atmospheres, such as in the presence of flammable liquids, gases or dust.** Power tools create sparks which may ignite the dust or fumes.
- 3. Keep children and bystanders away while operating a power tool.** Distractions can cause you to lose control.

### ELECTRICAL SAFETY

- 1. Power tool plugs must match the outlet. Never modify the plug in any way. Do not use any adapter plugs with earthed (grounded) power tools.** Unmodified plugs and matching outlets will reduce risk of electric shock.
- 2. Avoid body contact with earthed or grounded surfaces such as pipes, radiators, ranges and refrigerators.** There is an increased risk of electric shock if your body is earthed or grounded.
- 3. Do not expose power tools to rain or wet conditions.** Water entering a power tool will increase the risk of electric shock.
- 4. Do not abuse the cord. Never use the cord for carrying, pulling or unplugging the power tool. Keep cord away from heat, oil, sharp edges or moving parts.** Damaged or entangled cords increase the risk of electric shock.
- 5. When operating a power tool outdoors, use an extension cord suitable for outdoor use.** Use of a cord suitable for outdoor use reduces the risk of electric shock.

- 6. If operating a power tool in a damp location is unavoidable, use a ground fault circuit interrupter (GFCI) protected supply.** Use of a GFCI reduces the risk of electric shock.

### PERSONAL SAFETY

- 1. Stay alert, watch what you are doing and use common sense when operating a power tool. Do not use a power tool while you are tired or under the influence of drugs, alcohol or medication.** A moment of inattention while operating power tools may result in serious personal injury.
- 2. Use personal protective equipment. Always wear eye protection.** Protective equipment such as a respiratory mask, non-skid safety shoes and hearing protection used for appropriate conditions will reduce the risk of personal injury.
- 3. Prevent unintentional starting. Ensure the switch is in the off-position before connecting to power source and/or battery pack, picking up or carrying the tool.** Carrying power tools with your finger on the switch or energizing power tools that have the switch on invites accidents.
- 4. Remove any adjusting key or wrench before turning the power tool on.** A wrench or a key left attached to a rotating part of the power tool may result in personal injury.
- 5. Do not overreach. Keep proper footing and balance at all times.** This enables better control of the power tool in unexpected situations.
- 6. Dress properly. Do not wear loose clothing or jewelry. Keep your hair and clothing away from moving parts.** Loose clothes, jewelry or long hair can be caught in moving parts.

# GENERAL SAFETY RULES

 **WARNING!** Read all safety warnings and all instructions. Failure to follow the warnings and instructions may result in electric shock, fire and/or serious injury.

Safety is a combination of common sense, staying alert and knowing how your item works. The term “power tool” in the warnings refers to your mains-operated (corded) power tool or battery-operated (cordless) power tool.

## SAVE THESE SAFETY INSTRUCTIONS.

**7. If devices are provided for the connection of dust extraction and collection facilities, ensure these are connected and properly used.** Use of dust collection can reduce dust-related hazards.

### POWER TOOL USE AND CARE

**1. Do not force the power tool. Use the correct power tool for your application.** The correct power tool will do the job better and safer at the rate for which it was designed.

**2. Do not use the power tool if the switch does not turn it on and off.** Any power tool that cannot be controlled with the switch is dangerous and must be repaired.

**3. Disconnect the plug from the power source and/or the battery pack from the power tool before making any adjustments, changing accessories, or storing power tools.** Such preventive safety measures reduce the risk of starting the power tool accidentally.

**4. Store idle power tools out of the reach of children and do not allow persons unfamiliar with the power tool or these instructions to operate the power tool.** Power tools are dangerous in the hands of untrained users.

**5. Maintain power tools. Check for misalignment or binding of moving parts, breakage of parts and any other condition that may affect the power tool's operation. If damaged, have the power tool repaired before use.** Many accidents are caused by poorly maintained power tools.

**6. Keep cutting tools sharp and clean.** Properly maintained cutting tools with sharp cutting edges are less likely to bind and are easier to control.

**7. Use the power tool, accessories and tool bits, etc. in accordance with these instructions, taking into account the working conditions and the work to be performed.** Use of the power tool for operations different from those intended could result in a hazardous situation.

**8. Use clamps to secure your workpiece to a stable surface.** Holding a workpiece by hand or using your body to support it may lead to loss of control.

**9. KEEP GUARDS IN PLACE** and in working order.

### SERVICE

**1. Have your power tool serviced by a qualified repair person using only identical replacement parts.** This will ensure that the safety of the power tool is maintained.

### CALIFORNIA PROPOSITION 65 WARNING

Some dust created by power sanding, sawing, grinding, drilling, and other construction activities may contain chemicals, including lead, known to the State of California to cause cancer, birth defects, or other reproductive harm. Wash hands after handling. Some examples of these chemicals are:

- Lead from lead-based paints.
- Crystalline silica from bricks, cement, and other masonry products.
- Arsenic and chromium from chemically treated lumber.

Your risk from these exposures varies depending on how often you do this type of work. To reduce your exposure to these chemicals, work in a well-ventilated area with approved safety equipment such as dust masks specially designed to filter out microscopic particles.

## MITER SAW SAFETY WARNINGS

 **WARNING!** Do not operate the miter saw until you have read and understood the following instructions and the warning labels.

### SAW BLADE SAFETY

1. Always wear protective gloves when handling saw blades.
2. Only use blades with correct size and type for both your miter saw and your workpiece.
  - The rated diameter of the saw blade is 12" with a 1" arbor.
  - The no-load speed of the miter saw is 3800 RPM. The maximum permissible speed of your saw blade should always be higher than the no-load rotational speed of the saw.
3. Never use damaged or deformed saw blades. Only use sharp blades.
4. Install the saw blade in the correct orientation indicated in the instructions (see "Changing the Saw Blade", p. 17).
5. Keep hands out of path of saw blade. Never use your hands to remove sawdust, chips or workpiece near the saw blade or the cutting path of the saw.
6. Never reach around saw blade or reach in back of the saw blade.
7. Do not use blades made from high-speed steel, abrasive blades, metal-cutting blades or masonry-cutting blades. The guards of this saw are not designed to protect against the failure of such blades.
8. The use of accessories or attachments not recommended by the manufacturer may result in a risk of personal injury.

### PERSONAL SAFETY

1. Operate in a well ventilated area. Keep the floor area around the miter saw level and free of slippery substances or other tripping hazards.
2. Wear ANSI-approved safety goggles to protect your eyes from sparks and saw dust. Use hearing protection to protect yourself from hearing loss.

3. People with pacemakers should consult their physician(s) before use. Electromagnetic fields in close proximity to pacemakers could cause pacemaker interference or pacemaker failure.

4. Wear work gloves when handling saw blades. DO NOT wear gloves while operating the saw.

5. Sawdust is harmful to your health. Use NIOSH-approved dust masks or other respiratory protection during operation and cleaning.

6. Always turn off and unplug the miter saw before making any adjustments or repair tasks. Never adjust the miter saw or the workpiece while the saw is running.

7. The lock down pin is to be used only to lock the head in place for carrying and storage. It is not to be used for any cutting operation.

8. Never use damaged or incorrect blade flanges or bolt. The blade flanges and bolt were specially designed for your saw, for optimum performance and safety of operation.

9. Do not use to cut metal, logs, tree limbs, or uneven lumber.

10. Wet lumber, green (unseasoned) lumber, and pressure treated lumber all have an increased potential for kickback and should only be cut with a blade specifically designed for that lumber type. Wear a NIOSH-approved respirator and have appropriate ventilation whenever cutting pressure treated lumber.

### PREPARING THE MITER SAW

1. When transporting the miter saw, carry it by either the carrying handle or the base. Never carry the device by its guards or its accessories. Make sure that the lower part of the saw blade is covered by the blade guard during transportation.

2. Securely bolt the miter saw onto a miter saw stand or a workbench before operating.

# MITER SAW SAFETY WARNINGS

 **WARNING!** Do not operate the miter saw until you have read and understood the following instructions and the warning labels.

3. Examine the miter saw for any damaged or missing parts. Replace or repair damaged parts before operation. Periodically check that all nuts, bolts and other fasteners are properly tightened.

## SECURE YOUR WORKPIECE

1. Always position the workpiece on the miter table and firmly against the fence. Use the included hold-down clamp to secure the workpiece. Never perform any operation freehand.

2. Use a clamp or other securing methods to support the workpiece whenever possible.

3. When cutting round workpieces, use clamps on both sides of the table to prevent the workpiece from turning. Position the convex (curved) side against the fence.

4. Always support long workpieces properly using stands or roller tables.

5. Never hand-hold a workpiece that is too small to be clamped, as it can be launched away and cause injury. Use proper support and guides to secure the small workpiece.

## DURING CUTTING OPERATIONS

1. Make sure the path of the saw blade is clear of obstruction. Before turning on the miter saw, do a dry run and make sure that the saw blade does not touch anything other than the workpiece during its entire line of travel.

2. Always stand to one side when operating the saw. Never have any part of the body in line with the path of the saw.

3. Feed work into a blade against the direction of rotation of the blade only.

4. Do not use the miter saw unless all guards are in place. Do not operate with any guard disabled, damaged, or removed. Moving guards must move freely and close instantly.

5. Turn on the miter saw and let it reach full speed, then slowly lower the saw into the workpiece. This will help produce safer and cleaner cuts.

6. During slide cutting, always push the saw blade away from you. Do not pull the saw towards you.

7. Never cut more than one piece at a time. Do not stack workpieces together.

8. Turn off tool and wait for saw blade to stop before moving workpiece or changing settings. Do not slow or stop a blade with a piece of wood. Let the blade come to rest naturally. Do not attempt to free a jammed blade while the machine is still running.

9. To reduce risk of injury, return carriage to the full rear position after each crosscut operation.

## LASER SAFETY

 **ATTENTION: LASER RADIATION.** Class 2 laser.  
**DO NOT STARE INTO THE BEAM**

1. Do not look directly into the laser beam with unprotected eyes. Never look into the path of the beam.

2. Never point the laser beam towards reflecting surfaces. Never point the laser towards people or animals. Even a laser beam with a low output can cause damage to the eyes.

3. Never open the laser module as unexpected exposure to the beam can occur. The laser cannot be replaced with a different type of laser.

4. Repairs of the laser may only be carried out by the laser manufacturer or an authorized representative.

# ELECTRICAL INFORMATION

## GROUNDING INSTRUCTIONS

IN THE EVENT OF A MALFUNCTION OR BREAKDOWN, grounding provides the path of least resistance for an electric current and reduces the risk of electric shock. This tool is equipped with an electric cord that has an equipment grounding conductor and a grounding plug. The plug **MUST** be plugged into a matching outlet that is properly installed and grounded in accordance with ALL local codes and ordinances.

**DO NOT MODIFY THE PLUG PROVIDED.** If it will not fit the outlet, have the proper outlet installed by a licensed electrician.

**IMPROPER CONNECTION** of the equipment grounding conductor can result in electric shock. The conductor with the green insulation (with or without yellow stripes) is the equipment grounding conductor. If repair or replacement of the electric cord or plug is necessary, **DO NOT** connect the equipment grounding conductor to a live terminal.

**CHECK** with a licensed electrician or service personnel if you do not completely understand the grounding instructions or whether the tool is properly grounded.

**USE ONLY THREE-WIRE EXTENSION CORDS** that have three-pronged plugs and outlets that accept the tool's plug (Fig. 1). Repair or replace a damaged or worn cord immediately.

**CAUTION:** In all cases, make certain the outlet in question is properly grounded. If you are not sure, have a licensed electrician check the outlet.

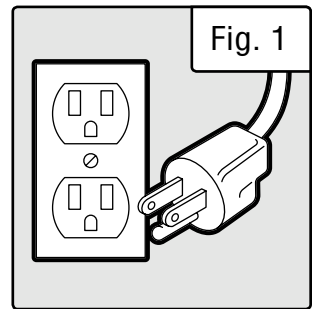

## GUIDELINES AND RECOMMENDATIONS FOR EXTENSION CORDS

When using an extension cord, be sure to use one heavy enough to carry the current your product will draw. An undersized cord will cause a drop in line voltage resulting in loss of power and overheating. The table below shows the correct size to be used according to cord length and ampere rating. When in doubt, use a heavier cord. The smaller the gauge number, the heavier the cord.

AMPERAGE	REQUIRED GAUGE FOR EXTENSION CORDS			
	25 ft.	50 ft.	100 ft.	150 ft.
15A	14 gauge	12 gauge	Not Recommended	

1. **EXAMINE EXTENSION CORD BEFORE USE.** Make sure your extension cord is properly wired and in good condition. Always replace a damaged extension cord or have it repaired by a qualified person before using it.

2. **DO NOT ABUSE EXTENSION CORD.** Do not pull on cord to disconnect from receptacle; always disconnect by pulling on plug. Disconnect the extension cord from the receptacle before disconnecting the product from the extension cord. Protect your extension cords from sharp objects, excessive heat and damp/wet areas.

3. **USE A SEPARATE ELECTRICAL CIRCUIT FOR YOUR TOOL.** This circuit must not be less than a 12-gauge wire and should be protected with a 15A time-delayed fuse. Before connecting the motor to the power line, make sure the switch is in the OFF position and the electric current is rated the same as the current stamped on the motor nameplate. Running at a lower voltage will damage the motor.



# UNPACKING & TRANSPORTATION

## UNPACKING

With the help of a friend or trustworthy foe, carefully remove the miter saw from the packaging. Make sure to take out all contents and accessories. Do not discard the packaging until everything is removed. Check the packing list below to make sure you have all of the parts and accessories. If any part is missing or broken, please contact our customer service at 1-800-232-1195.

## PACKING LIST

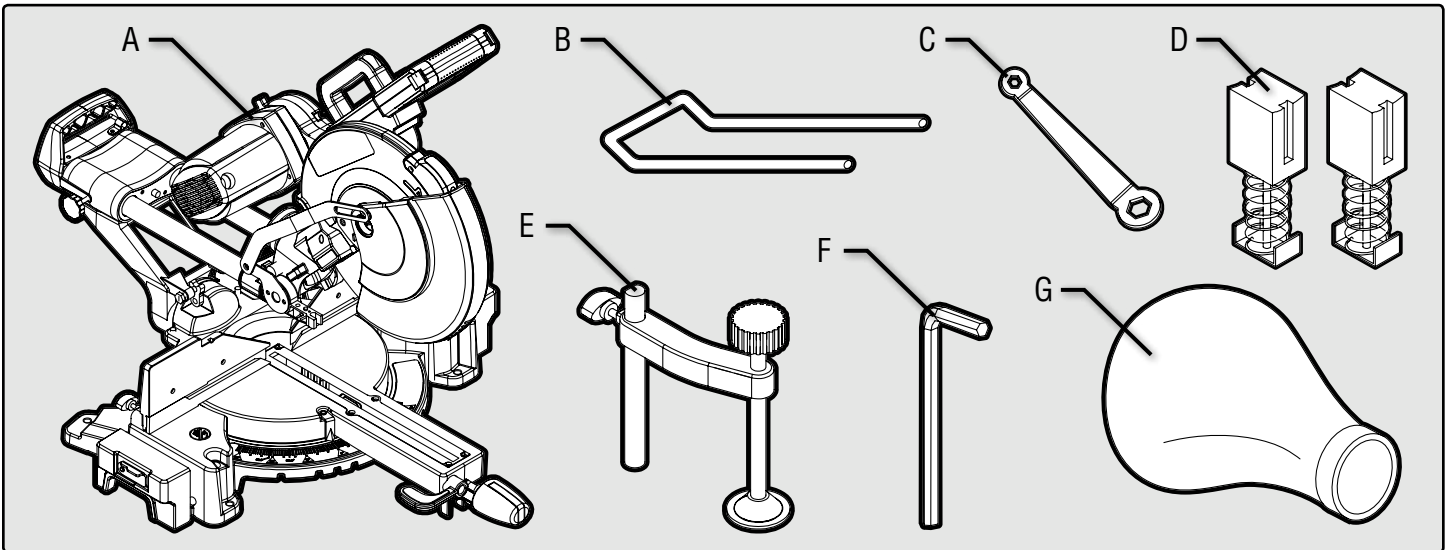

- A. Miter Saw (1)
- B. Support Stand (1)
- C. 10mm/13mm Box-End Wrench (1)
- D. Carbon Brush Replacement (2)
- E. Clamp Assembly (1)
- F. 6mm Hex Wrench (1)
- G. Dust Collection Bag (1)

The tools listed below are not included but are required for either assembly or adjustment.

- Mounting Hardware
- Combination Square
- Phillips-head Screwdriver

## TRANSPORTING THE MITER SAW

Before transporting your miter saw, make sure saw arm is locked down, the miter table is locked in position and the slide lock knob is tightened. Only lift the saw by the carrying handle located on top of the belt housing or at the back of the rails. Do not lift the saw using the guards or the operating handle.

**⚠ WARNING:** Do not plug in or turn on the tool until it is fully assembled according to the instructions. Failure to follow the safety instructions may result in serious personal injury.

# KNOW YOUR MITER SAW

## TOOL PURPOSE

Miter Saws allow you to easily make cuts at a variety of angles. Refer to the following diagrams to become familiarized with all the parts and controls of your miter saw. The components will be referred to later in the manual for assembly and operation instructions.

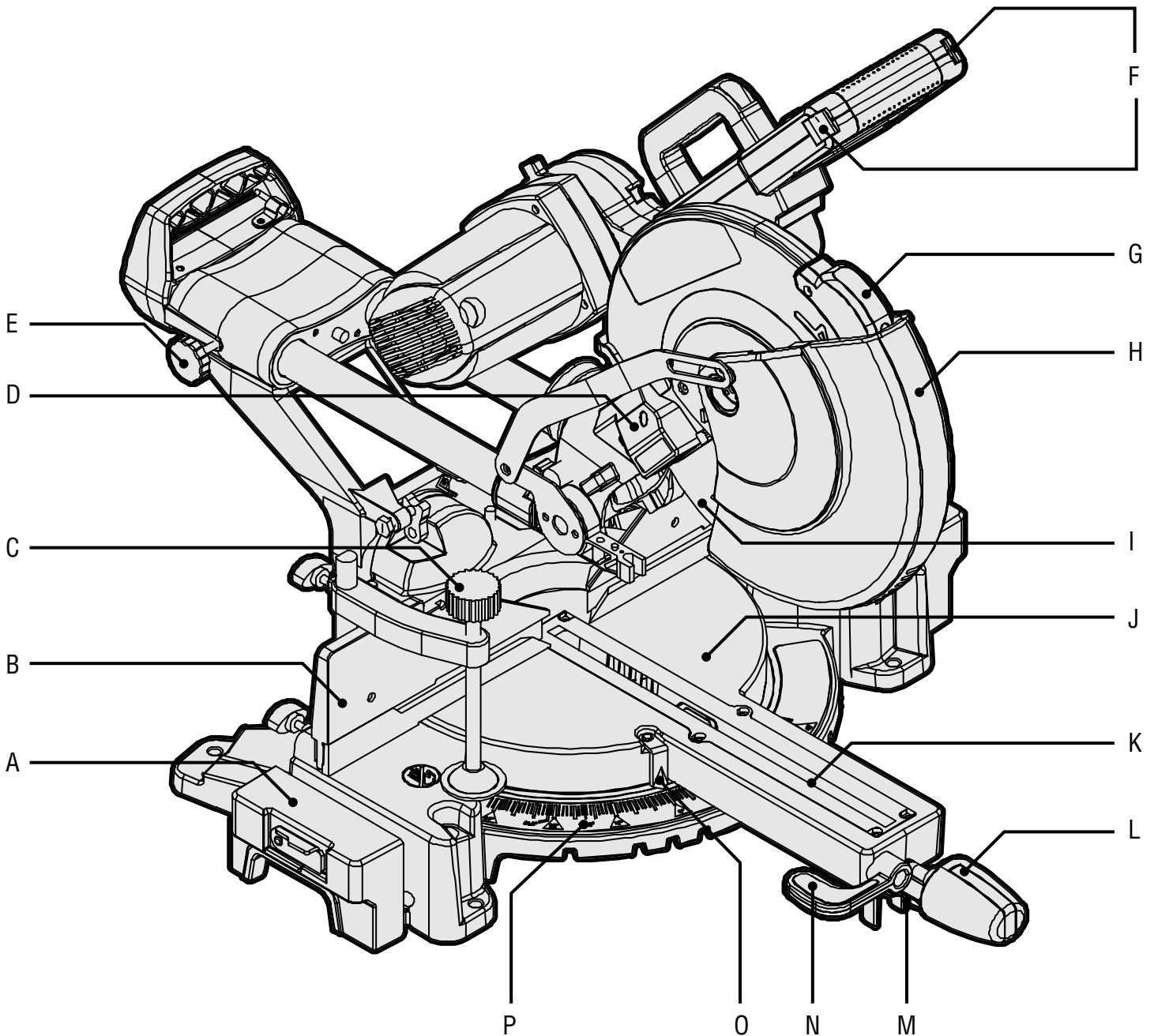

- A. Table Extension
- B. Fence
- C. Clamp Assembly
- D. LED Work Light
- E. Slide Lock Knob
- F. Trigger Locks

- G. Laser
- H. Lower Blade Guard
- I. Blade
- J. Miter Table
- K. Kerf Board
- L. Miter Lock Knob

- M. Miter Stop Lever
- N. Bevel Lock Lever
- O. Miter Angle Indicator
- P. Miter Scale

# KNOW YOUR MITER SAW

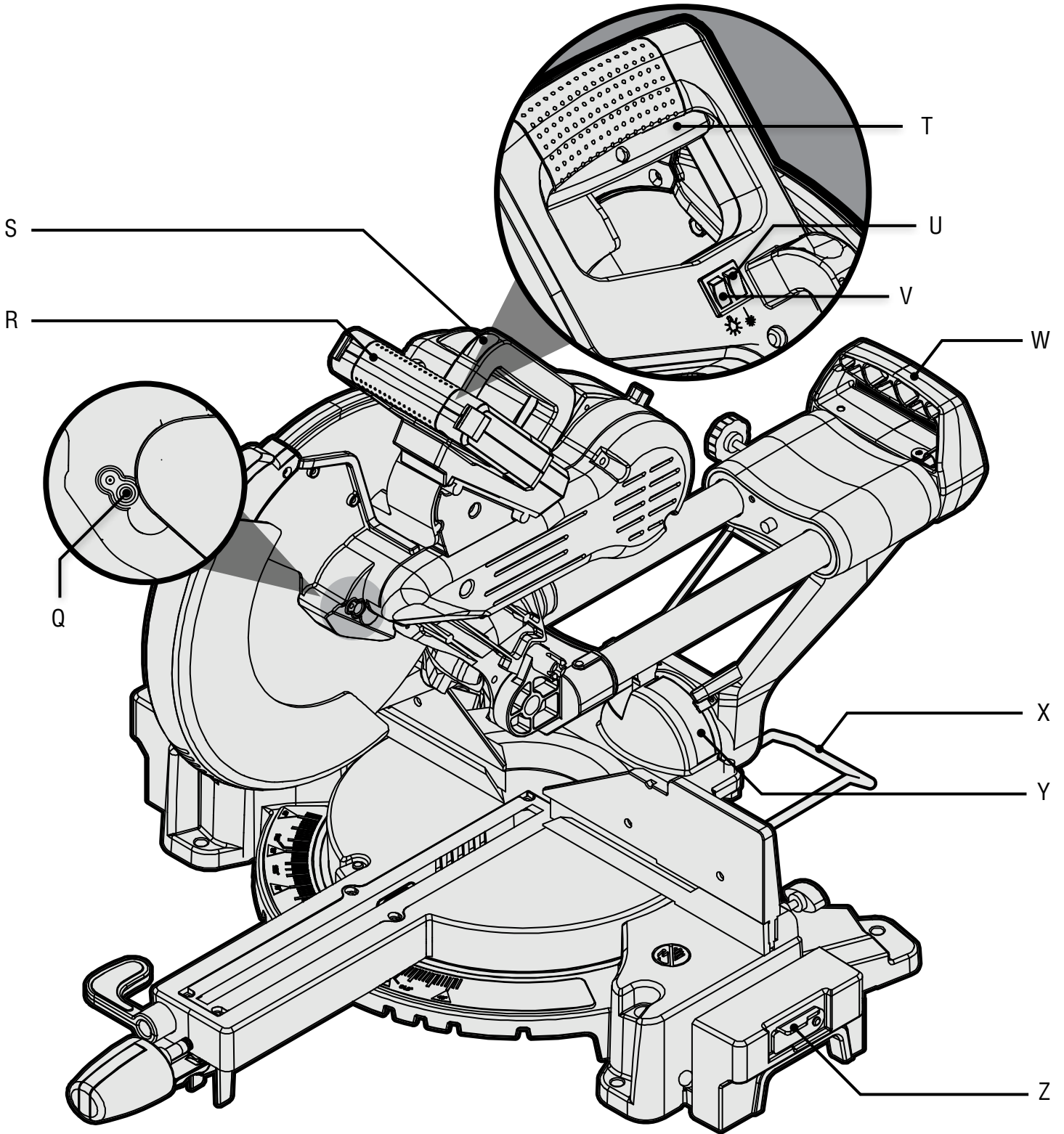

Q. Spindle Lock  
R. Operating Handle  
S. Carrying Handle  
T. Power Trigger

U. Laser ON/OFF  
V. Work Light ON/OFF  
W. Rear Carrying Handle  
X. Support Stand

Y. Bevel Scale  
Z. Stop Plate

## ASSEMBLY & ADJUSTMENTS

**⚠ WARNING:** Do not plug in or turn on the tool until it is fully assembled according to the instructions. Read through and become familiarized with the following procedures of handling and adjusting your miter saw. Failure to follow the safety instructions may result in serious personal injury.

### GUARD OPERATION

**NOTE:** Keep hands clear of the blade when the operating handle is lowered. Do not interfere with the proper movement of the blade guard.

**When the handle is lowered**, the blade guard raises automatically. **When the handle is raised**, the blade guard returns to its safety position, covering the blade.

### RAISING/LOWERING THE SAW ARM

The saw arm needs to be raised up before operation and locked down for transporting and storing.

#### To raise saw arm from the lower position:

1. Holding the operating handle (Fig. 2 - 3), lightly press down on the saw arm and pull out the release knob (Fig. 2 - 2). Slowly raise the saw arm to the upper position.
2. Set the release knob pin into the deep groove (Fig. 3 - 1) to lock the cutting head. Set the release knob pin into the shallow groove (Fig. 3 - 2) to unlock the cutting head.

#### To lower saw arm from the upper position:

1. Holding the operating handle (Fig. 2 - 3), push the blade guard lever and pull out the release knob (Fig. 2 - 2).
2. Slowly lower the saw arm to the lower position and lock the release knob into the deep groove (Fig. 3 - 1).

### ADJUSTING THE BEVEL ANGLE

The saw arm can bevel from 0° to 45° to the left or right.

1. Unlock the bevel lock lever (Fig. 2 - 1) by rotating it upwards (clockwise).
2. Tilt the saw arm until the bevel angle indicator points to the desired angle on the bevel scale (Fig. 2 - 5).
3. Tighten the bevel lock lever (Fig. 2 - 1) by rotating it down (counterclockwise). Be sure to tighten firmly without over-tightening.

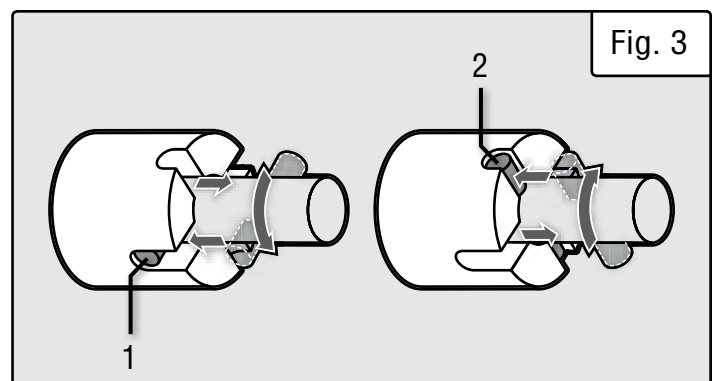
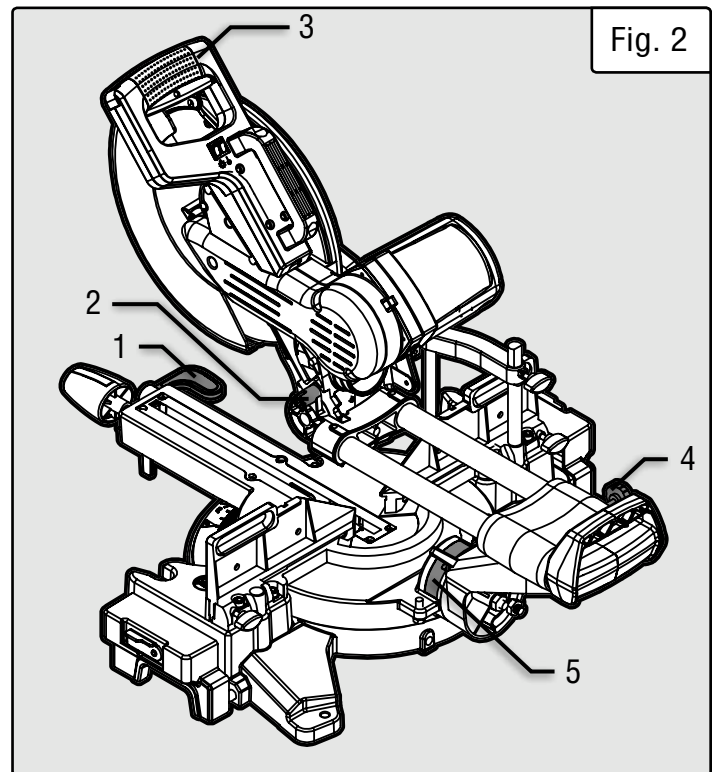

### SETTING UP ARM SLIDE

The saw arm can be adjusted to different lengths using the slide bar, and can slide back and forth when cross-cutting.

**For sliding cuts:** Loosen the slide lock knob (Fig. 2 - 4) and slide the saw arm to desired position.

**For non-sliding cuts and transportation:** Tighten the slide lock knob (Fig. 2 - 4) for non-sliding operations and before transporting the miter saw.

## ASSEMBLY & ADJUSTMENTS

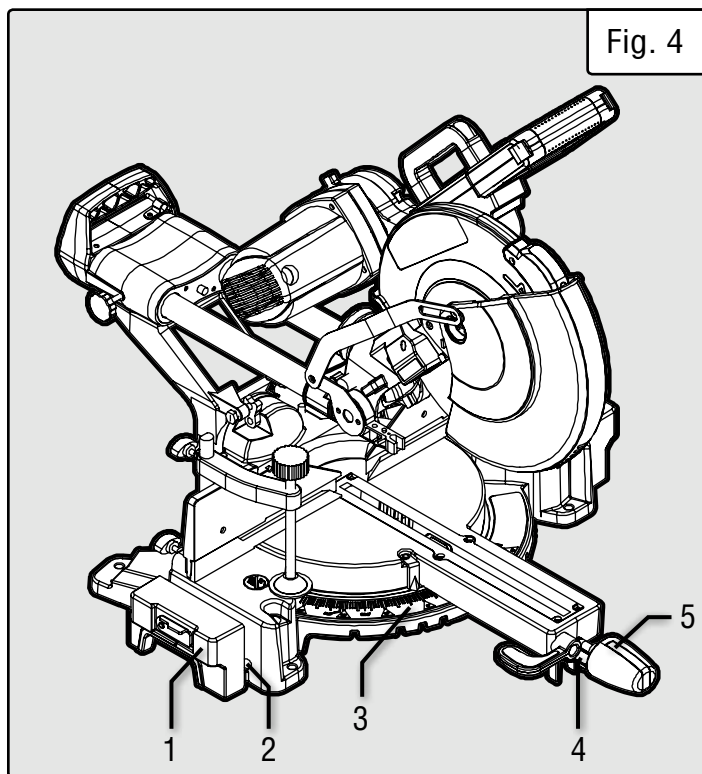

Fig. 4

### ADJUSTING THE MITER ANGLE

The miter table can be adjusted from 0° to 45° to both left and right to create miter cuts.

1. Loosen the miter lock knob (Fig. 4 - 5) by turning it one or two turns counterclockwise.

2. Pull up on the miter stop lever (Fig. 4 - 4) to unlock the table. While holding the miter stop lever up, adjust the table to the desired angle. The miter scale indicator (Fig. 4 - 3) will point towards the selected angle. To make micro adjustments to a specific angle, rotate the table while pulling up on the miter stop lever. The miter table has positive stops at 0°, 15°, 22.5°, 30°, and 45° in both directions for quick adjustments.

3. After selecting your miter angle, release the miter stop lever and tighten the miter lock knob (Fig. 4 - 5) by turning it clockwise to lock the table in place.

**WARNING:** Be sure the miter table is locked in place before making a cut. Failure to do so can cause the table to move during the cut, which could result in serious personal injury.

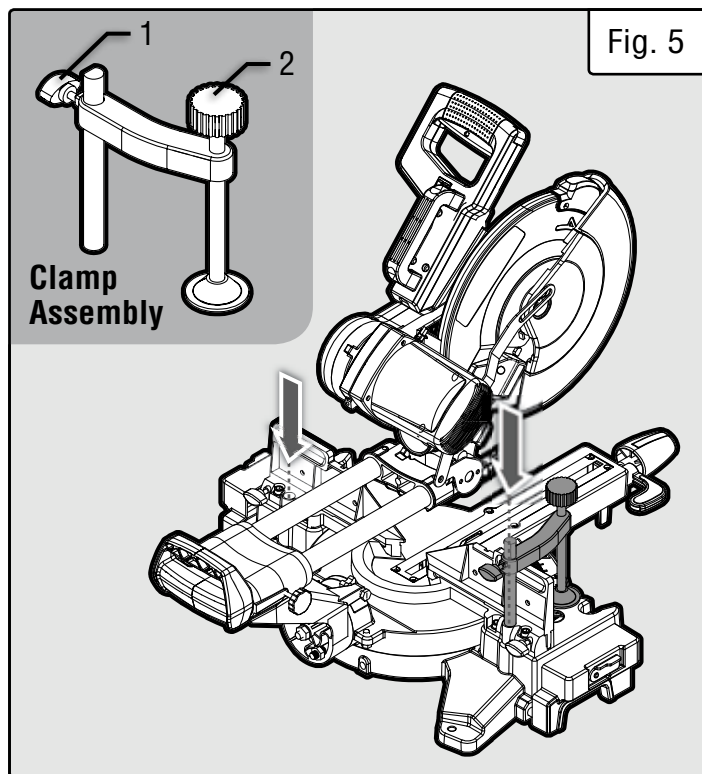

Fig. 5

### USING THE TABLE EXTENSIONS

The table extensions (Fig. 4 - 1) come pre-installed on either side of your miter saw and serve as extra support for your workpiece. Loosen the table extension knobs (Fig. 4 - 2) to adjust their positioning. The stop plate on each table extension can be raised to quickly and easily make repeated cuts.

### INSTALLING THE CLAMP ASSEMBLY

The clamp comes pre-assembled and can be mounted on the left or right side of the saw depending on the cutting task at hand.

1. Locate the hole for the clamp on the left or right side of the miter saw behind the fence (Fig. 5 - arrows). Insert the clamp assembly (Fig. 5) into the slot.

2. Secure the clamp into place by tightening the clamp lock screw (Fig. 5 - 1).

**NOTE:** Check that the clamp won't interfere with the blade travel before operating the saw.

3. Rotate the clamp knob (Fig. 5 - 2) to move it up or down as needed to securing the workpiece. Check that the workpiece is secure and does not wobble before cutting.

## ASSEMBLY & ADJUSTMENTS

**⚠ WARNING:** Do not plug in or turn on the tool until it is fully assembled according to the instructions. Read through and become familiarized with the following procedures of handling and adjusting your miter saw. Failure to follow the safety instructions may result in serious personal injury.

### INSTALLING THE SUPPORT STAND

The support stand offers additional stability for your miter saw. Follow the instructions below to install the support stand.

1. Locate the two holes for the support stand on the back of the miter saw (Fig. 6 - arrows). Loosen the Phillips-head screw on the bottom of the left hole (Fig. 6 - 2), then insert the support stand (Fig. 6 - 1) into the holes.
2. Secure the stand into place by tightening the stand lock screw (Fig. 6 - 1). See p. 11 - X for installation orientation.

### BENCH MOUNTING

1. The miter saw base has four holes on the base for bench mounting (Fig. 7 - arrows). Mount and fix the saw to a level, horizontal bench, worktable, or miter saw stand (compatible with WEN Models MSA330 and MSA750) using four bolts and nuts (not included).
2. If desired, you can mount the saw to a piece of 1/2" or thicker plywood which can then be clamped to your work bench or moved to other job sites and reclamped.

**CAUTION:** Make sure that the mounting surface is not warped. Uneven surfaces can cause binding and inaccurate sawing.

### INSTALLING THE DUST COLLECTION BAG

The dust collection bag should be used at all times. Follow the instructions below to install the bag.

1. Locate the dust port on the back of the miter saw (Fig. 8 - arrow).
2. Squeeze the metal clip on the dust collection bag to open the mouth of the bag. Slip the mouth of the dust collection bag over the dust port and release the clip to secure the bag to the outlet.
3. Open the zipper on the bottom of the bag to empty. For efficient operation, empty the dust bag when half full to allow for better air flow through the bag.

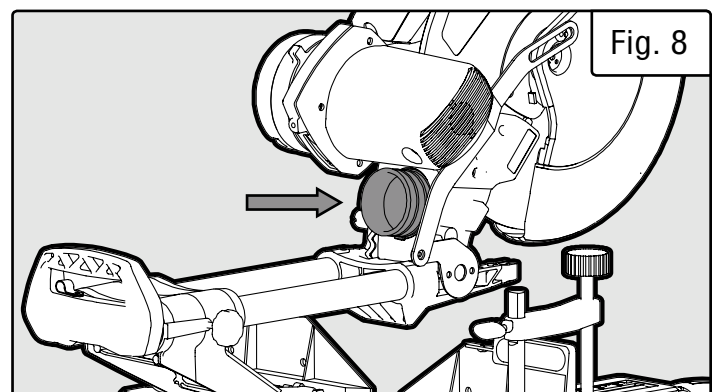
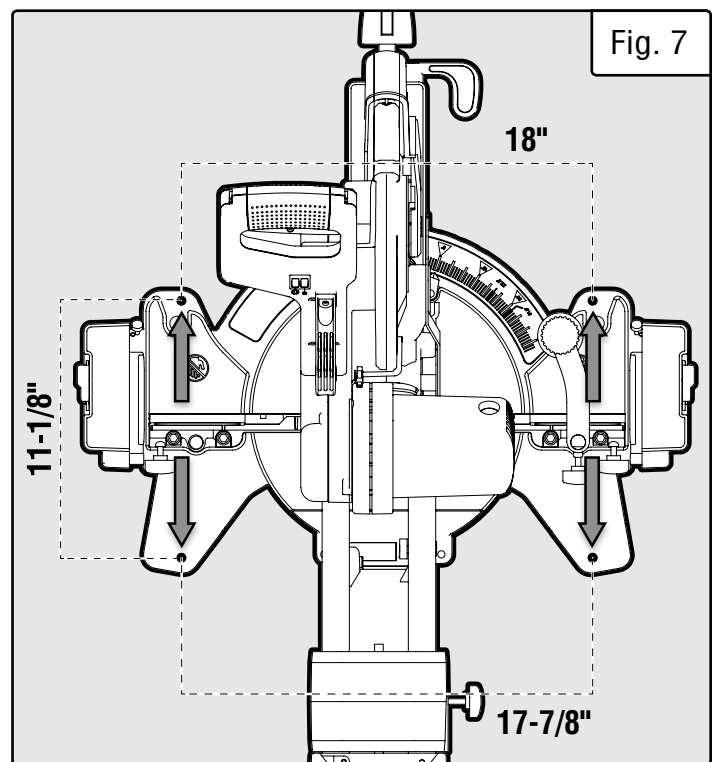
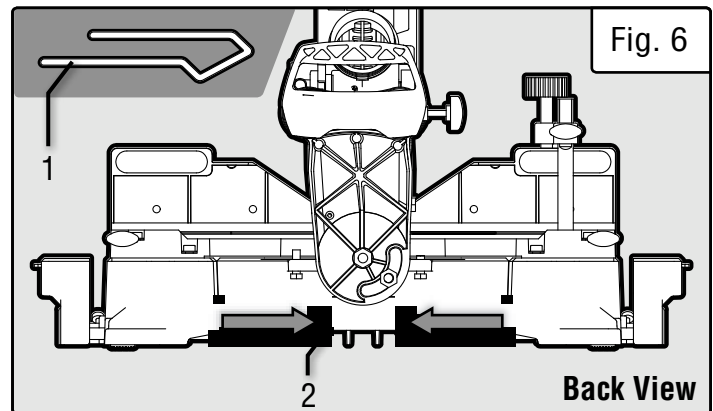

## ASSEMBLY & ADJUSTMENTS

**! WARNING:** Do not plug in or turn on the tool until it is fully assembled according to the instructions. Read through and become familiarized with the following procedures of handling and adjusting your miter saw. Failure to follow the safety instructions may result in serious personal injury.

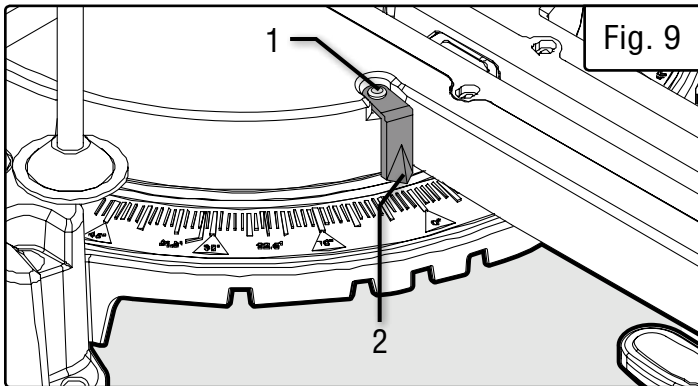

### SQUARING THE FENCE WITH THE BLADE

To make accurate cuts, the fence must be perpendicular to the saw blade.

1. Lower the saw arm down to the lower position and lock the release knob. See section titled, "Raising/Lowering the Saw Arm" on page 12.
2. Slide the saw arm to the back and tighten the slide lock knob. See section titled, "Setting Up Arm Slide" on page 12.
3. Set the miter table indicator (Fig. 9 - 2) to 0° and tighten the miter lock knob. Place a combination square (not included) against the fence and alongside the saw blade (should be in contact with the surface of the blade, not the teeth).
4. Slightly loosen the four fence adjusting bolts on the back of the fence (Fig. 10 - arrows) with the included hex wrench. Adjust the fence position until it is 90° with the blade. Tighten the four bolts to secure the fence.
5. Make a test cut. Repeat step 4 until your test cut is accurate.

### SETTING THE MITER SCALE INDICATOR

1. Loosen the screw (Fig. 9 - 1) holding the miter scale indicator.
2. Adjust the direction of the indicator (Fig. 9 - 2) so that it accurately points to 0° on the miter scale. Tighten the screw.

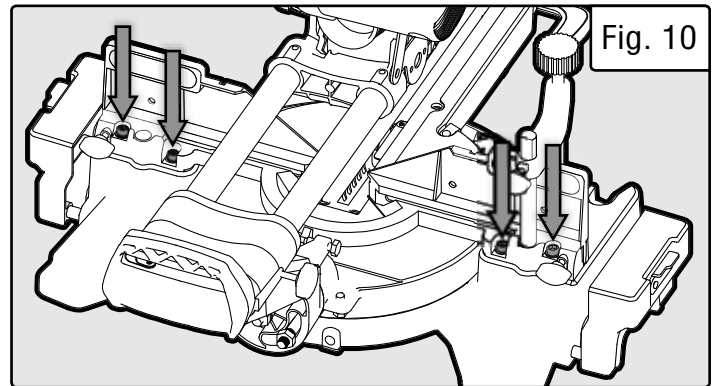

### SQUARING THE TABLE WITH THE BLADE

To make accurate cuts, the table must be perpendicular to the saw blade.

1. Lower the saw arm down to the lower position and lock the release knob. See section titled, "Raising/Lowering the Saw Arm" on page 12.
2. Slide the saw arm to the back and tighten the slide lock knob. See section titled, "Setting Up Arm Slide" on page 12.
3. Set the miter table indicator (Fig. 9 - 2) to 0° and tighten the miter lock knob. Set the bevel angle indicator to 0° (Fig. 11 - 6, p. 16) and tighten the bevel lock lever.
4. Place a combination square (not included) against the table and alongside the saw blade (should be in contact with the surface of the blade, not the teeth). Wearing work gloves, rotate the blade by hand and check the blade-to-table alignment at several points. The edge of the combination square and the saw blade should be parallel. If the saw blade tilts away from the combination square, continue on with the steps on the following page.

**! WARNING:** To prevent serious injury, after making any adjustments to the cutting angle, make sure the both sides of the fence are clear of the blade's cutting path. With the power OFF, move the blade through its full range of motion to check this.

**Instructions continue on the next page.**

## ASSEMBLY & ADJUSTMENTS

**⚠ WARNING:** Do not plug in or turn on the tool until it is fully assembled according to the instructions. Read through and become familiarized with the following procedures of handling and adjusting your miter saw. Failure to follow the safety instructions may result in serious personal injury.

5. Flip the bevel stop block (Fig. 11 - 4) up. Loosen the zero stop lock nut (Fig. 11 - 2) and adjust the zero stop screw (Fig. 11 - 1) until the table is 90° with the blade. Tighten the zero stop lock nut to secure the blade.

6. Make a test cut. Repeat step 5 until your test cut is accurate.

**NOTE:** To adjust one of the 45° bevel stop screws (Fig. 11 - 3 & 7), loosen the bevel adjustment nut (Fig. 11 - 8), flip down the bevel stop block, and turn the bevel adjustment screw (Fig. 11 - 7) using a hex wrench. Turn clockwise to increase the bevel and counterclockwise to decrease the bevel. Tighten the nut after adjustment.

### SETTING THE BEVEL SCALE INDICATOR

1. Before setting the bevel scale indicator, the table must be perpendicular to the saw blade. See section titled, "Squaring the Table with the Blade" on page 15.

2. Loosen the screw (Fig. 11 - 5) holding the bevel scale indicator.

3. Adjust the direction of the indicator so that it accurately points to 0° on the bevel scale. Tighten the screw.

### ADJUSTING THE CUTTING DEPTH

The saw cutting depth can be adjusted if you would like to perform a kerfing or rabbet cut that does not cut all the way through the workpiece.

**⚠ WARNING:** Only adjust the front bolt (Fig. 12 - 1). The rear bolt is used to prevent the blade from cutting the table during normal cutting. DO NOT adjust the rear depth bolt.

1. Unplug the tool from its power source and raise the saw head assembly.

2. Locate the depth stop settings on the left side of the saw (Fig. 12). Rotate the depth stop plate (Fig. 12 - 3) to the left to use the depth stop bolt setting.

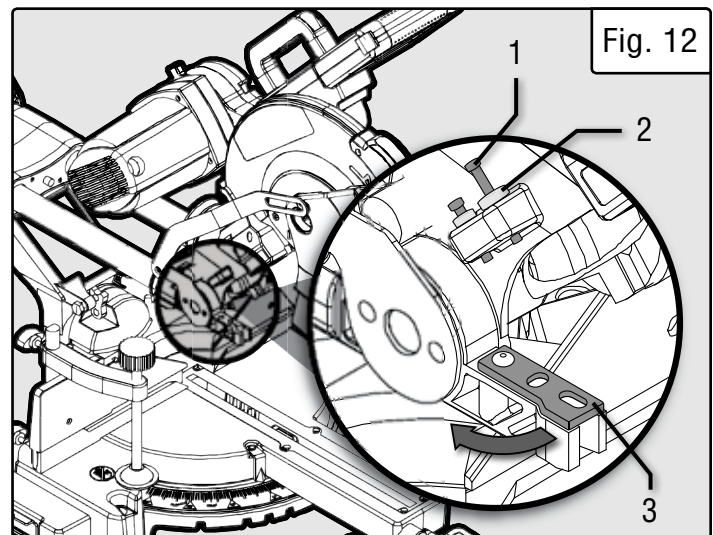
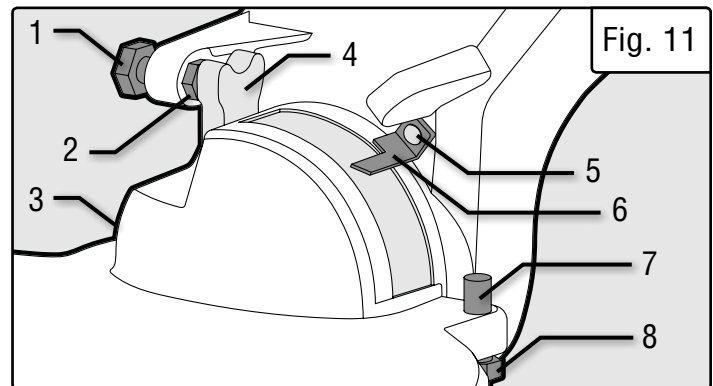

3. Pull down on the saw head to check the current setting. To change the setting, continue to step 4.

4. Loosen the depth stop nut (Fig. 12 - 2) on the depth stop bolt (Fig. 12 - 1). **To decrease depth**, turn the depth stop bolt clockwise. **To increase depth**, turn the depth stop bolt counterclockwise. Tighten the nut after adjustment.

**NOTE:** If needed, push the depth stop plate (Fig. 12 - 3) to the position shown in Fig. 12 to temporarily disable it. Make sure the depth stop is properly aligned to allow the bolt to pass through it.

5. Check the cutting depth setting by completing a test cut on a piece of scrap wood. Repeat steps 4 - 5 until the desired depth is achieved.



## ASSEMBLY & ADJUSTMENTS

**⚠ WARNING:** Do not plug in or turn on the tool until it is fully assembled according to the instructions. Read through and become familiarized with the following procedures of handling and adjusting your miter saw. Failure to follow the safety instructions may result in serious personal injury. Wear gloves while changing the blade.

### CHANGING THE SAW BLADE

**DANGER!** Never try to use a blade larger than the stated capacity of the saw. Do not use a blade thicker than 1.9mm. It will prevent the blade screw from properly securing the blade on the spindle. Install the suitable blade for your cutting operation.

1. Unplug the tool from its power source. Place a piece of paper on the miter table to catch the screws.

2. Lift the saw arm to the upper position and lock it in place. Raise the lower blade guard (Fig. 13 - 2) out of the way and hold it up. Loosen the lower blade guard screw (Fig. 14 - 1) with a Phillips-head screwdriver (not included) until it disengages the guard plate (Fig. 14 - 2). Swing the guard plate up and out of the way. **NOTE:** the safety guard does not need to be taken off from the saw.

3. Firmly press down the saw spindle lock (p. 11 - Q) on the back of the saw's head and hold it in. Use the 13mm box-end wrench to turn the arbor bolt (Fig. 15) clockwise and remove it (the bolt is left-hand threaded), remove outer flange (Fig. 16 - 4), and arbor insert (Fig. 16 - 2). Make sure the inner flange (Fig. 16 - 5) stays in place on the spindle (Fig. 16 - 6).

4. Slowly remove the blade by pulling it out and down. Clean the arbor bolt (Fig. 15 - 3), outer flange (Fig. 15 - 4), and arbor insert (Fig. 15 - 2).

5. Place the arbor insert (Fig. 16 - 2) onto the spindle (Fig. 16 - 6). Place the new blade over the arbor insert.

**IMPORTANT:** Make sure the blade's rotation arrow points in the same direction as the rotation arrow on the upper blade guard (Fig. 16 - 7).

6. Reinstall the outer flange and arbor bolt. Hold down the spindle lock and tighten the arbor bolt with the 13mm box-end wrench, turning it counterclockwise. Release the spindle lock.

7. Return the guard plate (Fig. 14 - 2) back into place, and secure it with the guard plate screw (Fig. 14 - 1).

**IMPORTANT:** Carefully rotate the saw blade and make sure that it does not wobble. Lower the saw arm and check if the blade spins freely in the table insert in both perpendicular and 45° angles. Make sure the lower blade guard operates properly before using the saw.

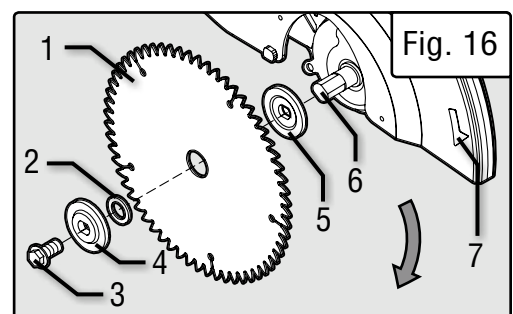
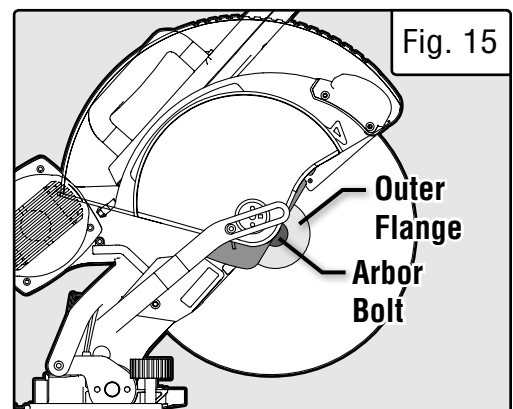
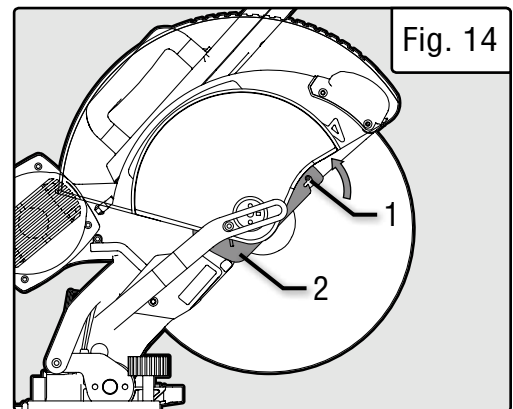
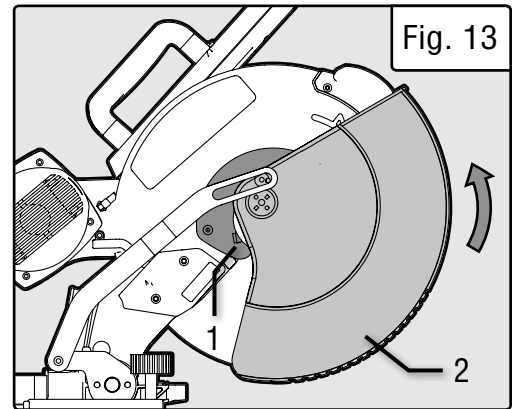

## ASSEMBLY & ADJUSTMENTS

**⚠ WARNING:** Do not plug in or turn on the tool until it is fully assembled according to the instructions. Read through and become familiarized with the following procedures of handling and adjusting your miter saw. Failure to follow the safety instructions may result in serious personal injury.

### ADJUSTING THE DRIVE BELT

1. Unplug the tool from its power source. Loosen the 3 screws securing the drive belt housing cover (Fig. 17) to the drive belt housing. Remove the drive belt housing cover.

2. Using a 5mm hex wrench (not included), loosen, but do not remove, the 6 hex screws (Fig. 18) that secure the motor to the belt drive housing.

3. Using a 4mm hex wrench (not included), turn counterclockwise to loosen the set screw (Fig. 19 - 1) at the top of the of the belt drive housing. This will release the tension on the drive belt and allow for adjustments or replacements of the belt.

4. Re-seat the belt on the pulley, making sure the belt is properly seated in the grooves of both pulleys. Re-tighten the belt by turning the set screw (Fig. 19 - 1) clockwise. Re-tighten the 6 hex screws (Fig. 18).

5. Test belt tension by squeezing both sides of the belt. If properly adjusted, the belt should “give” between 1/16" - 1/8" (1.5mm - 3mm). Make sure that the belt grooves are properly seated in the pulleys.

6. Carefully reinstall the drive belt housing cover by tightening the 3 screws (Fig. 17).

**NOTE:** Excessive tightness on the pulley belt will cause increased noise and motor overload. Premature failure will occur if the belt is too loose.

### ADJUSTING THE FENCES

1. Loosen the fence adjustment knob (Fig. 20 - 2).

2. Adjust the fence as desired. The top portion of the fence (Fig. 20 - 1) can slide to the left and right, while the bottom portion of the fence (Fig. 20 - 3) stays stationary.

3. Tighten the fence adjustment knob to lock the fence into place.

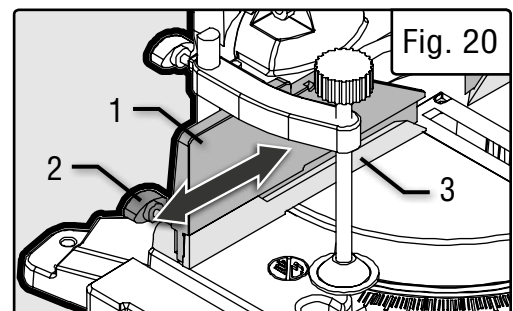
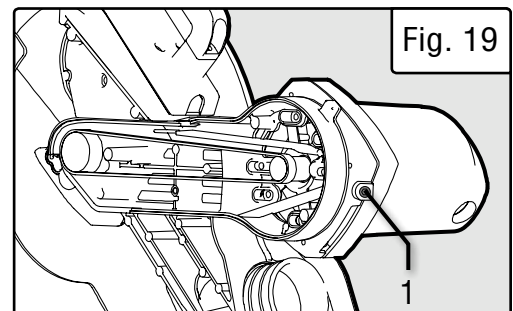
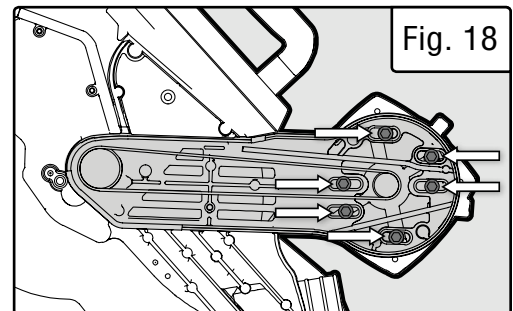
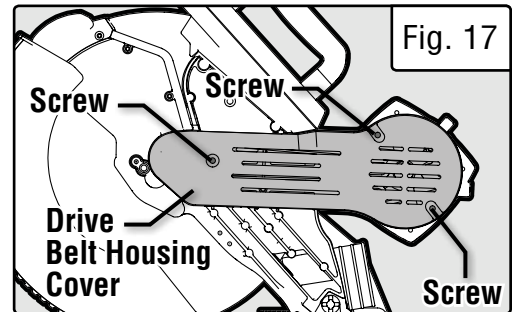

**⚠ WARNING:** To prevent serious injury, after making any adjustments to the cutting angle, make sure the both sides of the fence are clear of the blade's cutting path. With the power OFF, move the blade through its full range of motion to check this.

# OPERATION

**! WARNING:** Do not plug in or turn on the tool until it is fully assembled according to the instructions. Read through and become familiarized with the following procedures of handling and adjusting your miter saw. Failure to follow the safety instructions may result in serious personal injury.

## 1. RAISE THE SAW ARM

Before operation, raise the saw arm from the lower position. See section titled, "Raising/Lowering the Saw Arm" on page 12.

## 2. SET UP THE CUT ANGLE & DEPTH

The miter saw can be set up to create cuts at different angles by adjusting the angle of the miter table and the saw bevel angle. There are four types of cuts you can create: a cross cut, a miter cut, a bevel cut, and a compound cut. See Fig. 21 to understand each type of cut. If you do not want to cut all the way through your workpiece, adjust the cutting depth. See note below.

**To adjust the bevel angle:** see section titled, "Adjusting the Bevel Angle" on page 12. **To adjust the miter angle:** see section titled, "Adjusting the Miter Angle" on page 13. **To adjust the cutting depth:** see section titled, "Adjusting the Cutting Depth" on page 16.

## 2. SET UP SLIDING FUNCTION (FIG. 22)

**For materials with a width under 4 inches (100 mm):** the sliding function isn't necessary. See section titled, "Setting Up Arm Slide" on page 12 to disable the sliding function.

**For materials with a width over 4 inches (100 mm):** the saw arm will need to slide to cut through the workpiece. See section titled, "Setting Up Arm Slide" on page 12 to enable the sliding function.

## 4. SET UP WORKPIECE

Place the workpiece flat on the table with one edge securely against the fence.

**Warped Boards:** If the board is warped, place the convex side against the fence (Fig. 23). **CAUTION:** The board could break and jam the blade if the concave side is placed against the fence

**Long Boards:** When cutting long workpieces, support the opposite end of the material with the support table, a roller stand or a work surface that is level with the saw table.

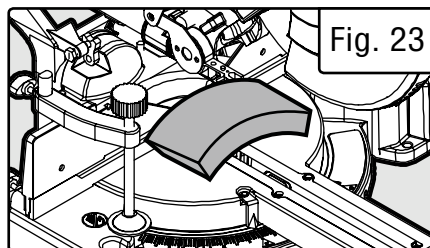
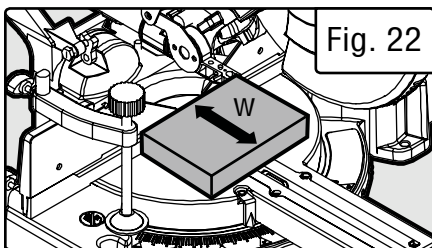
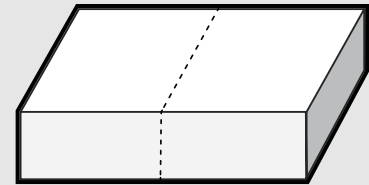

Fig. 21

### CROSS CUT

Miter table 0°, Saw arm 0°



### BEVEL CUT

Miter table 0°, Saw arm 0° - 45°

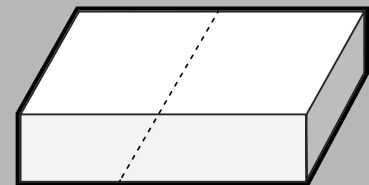

### MITER CUT

Miter table 0° - 45°, Saw arm 0°

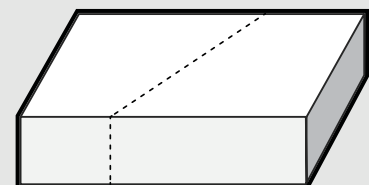

### COMPOUND CUT

Miter table 0° - 45°,  
Saw arm 0° - 45°

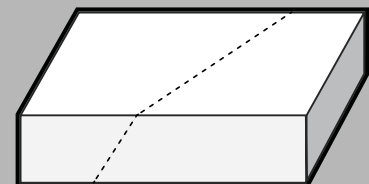

# OPERATION

**! WARNING:** Before operating the miter saw, make sure to equip yourself with a dust mask, ear protection, and safety glasses for protection from possible injuries. Tie back long hair and do not wear loose clothing or jewelry. DO NOT look into the laser beam, this can cause serious eye damage or blindness. Do not wear gloves while operating the saw.

## 5. SECURE WORKPIECE

Secure the workpiece with the clamping device on the fixed table whenever possible to prevent the material from moving during the cutting operations. See section, "Installing the Clamp Assembly" on page 13.

## 6. CHECK BEFORE OPERATION

- Check that the miter table does not rotate and the saw arm does not bevel.
- Check that the workpiece is fully supported, against the fence and securely clamped down.
- Check that you have the proper blade for the material you are cutting.
- Without turning on the saw, perform a dry run of the cutting operation to check that nothing is obstructing the path of the saw.

## 7. PERFORM THE CUT

1. Plug in the miter saw. Turn on the work light (Fig. 24 - 2) so you can easily see what you are working on. Turn on the laser (Fig. 24 - 1) to see where your cut will land on the material. **CAUTION:** DO NOT look into the laser beam.

2. Grip the operating handle firmly, press one of the blade trigger lock buttons (Fig. 24 - 4) with your thumb, and squeeze the power trigger (Fig. 24 - 3) to turn the saw ON. **NOTE:** The trigger locks are a safety feature that prevent the power trigger from being pressed down to reduce the risk of accidentally starting the machine.

2. Allow the blade to reach full speed. Make sure the workpiece is held securely against the table and fence at all times. If the material binds the blade, release the power trigger.

- **For non-sliding cuts:** Slowly lower the blade into and through the workpiece.
- **For sliding cuts:** Pull the saw arm all towards the front of the machine. Slowly lower the blade into the workpiece while steadily pushing it away from you until the workpiece is cut (Fig. 25). **CAUTION:** Never slide the saw arm towards yourself while cutting. Always push away.

3. Release the power trigger and wait until the blade fully stops before raising it from the workpiece.

4. Unplug the miter saw before leaving your work station. Clean your work station and store tools out of reach of children.

**! WARNING:** Be sure to tighten the miter lock and bevel lock before making a cut. Failure to do so could result in the table moving during the cut and may cause serious personal injuries.

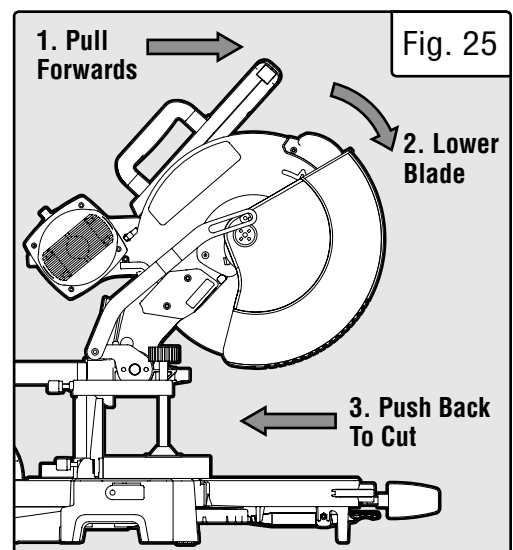
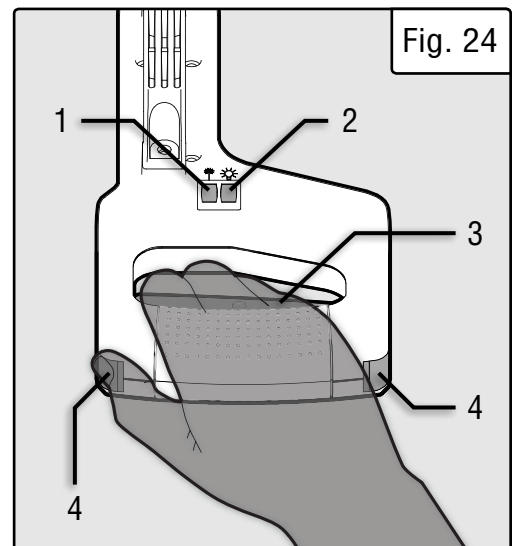

# MAINTENANCE

**⚠ WARNING:** To avoid accidents, turn OFF and unplug the tool from the electrical outlet before cleaning, adjusting, or performing any maintenance work.

**⚠ WARNING:** Any attempt to repair or replace electrical parts on this tool may be hazardous. Servicing of the tool must be performed by a qualified technician. When servicing, use only identical WEN replacement parts. Use of other parts may be hazardous or induce product failure.

## ROUTINE INSPECTION

Before each use, inspect the general condition of the tool. If any of these following conditions exist, do not use until parts are replaced or the sharpener is properly repaired.

### Check for:

- Loose hardware,
- Misalignment or binding of moving parts,
- Damaged cord/electrical wiring,
- Cracked or broken parts, and
- Any other condition that may affect its safe operation

## CLEANING & STORAGE

1. Keep the ventilation openings free from dust and debris to prevent the motor from overheating.

2. Wipe the tool surfaces clean with a clean cloth. Make sure water does not get into the tool.

3. Store the tool in a clean and dry place away from the reach of children. Store in temperatures between 41° to 86°F.

4. Cover the miter saw in order to protect it from dust and moisture. It is preferable to store it in its original packaging with the instruction manual.

## CARBON BRUSH REPLACEMENT

Replacement carbon brushes (Part No. MM1214-114) can be ordered at [wenproducts.com](http://wenproducts.com). Only genuine WEN replacement brushes designed specifically for your tool should be used.

1. To access the carbon brushes, remove the carbon brush cap (Fig. 26) with a flat-head screwdriver (not included).

2. Carefully remove the old carbon brushes using pliers.

3. Install the new carbon brushes. Both carbon brushes should be replaced at the same time. Replace the carbon brush cap. **NOTE:** New carbon brushes tend to spark for a few minutes during the first use as they wear down.

## PRODUCT DISPOSAL

Used power tools should not be disposed of together with household waste. This product contains electronic components that should be recycled. Please take this product to your local recycling facility for responsible disposal and to minimize its environmental impact.

**CAUTION:** Most plastics are susceptible to damage from various types of commercial solvents. Do not use any solvents or cleaning products that could damage the plastic parts. Some of these include but are not limited to: gasoline, carbon tetrachloride, chlorinated cleaning solvents, and household detergents that contain ammonia.

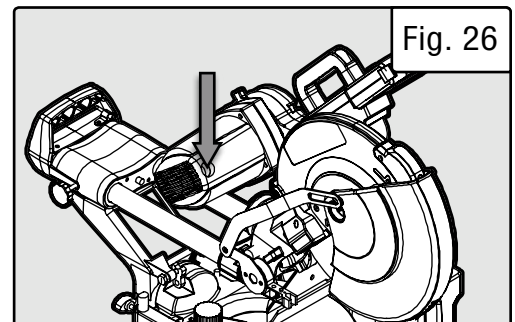

## TROUBLESHOOTING GUIDE

**⚠ WARNING:** Stop using the tool immediately if any of the following problems occur. Repairs and replacements should only be performed by an authorized technician. For any questions, please contact our customer service at (800) 232-1195, M-F 8-5 CST or email us at [techsupport@wenproducts.com](mailto:techsupport@wenproducts.com).

PROBLEM	CAUSE	SOLUTION
Ineffective cutting performance	Blade is dull	Sharpen or replace blade.
	Blade is dirty	Remove the blade and clean the surface and cutting edge with steel wool and turpentine.
	The blade is not secure	Make sure the blade flanges are flush against the blade and arbor bolt is tightened completely.
	Belt is worn	See page 18 to replace the belt.
	Incorrect blade used for workpiece	Ensure the blade is compatible with the material type and thickness being cut.
	Blade mounted backwards.	Mount blade in correct orientation.
Excessive noise or vibration	Not mounted properly	Make sure the saw is mounted securely to a flat and level work surface.
	Damaged saw blade	Replace blade.
	The blade is not secure	Make sure the blade flanges are flush against the blade and arbor bolt is tightened completely.
	Belt is worn	See page 18 to replace the belt.
Blade will not turn	Excessive sawdust or chips between blade and frame	Clean the space between the blade and frame with compressed air and ensure no chips are stuck within.
	Spindle lock is depressed	Move the blade back and forth to unlock the spindle lock button.
	Belt is broken	See page 18 to replace the belt.
Motor does not start	Power cord damaged or not properly plugged in	Check the power cord, extension cord, power plug and the power outlet. Do not use the tool if any cord is damaged.
	Defective power switch	Stop using the tool and contact customer service at (800) 232-1195, M-F 8-5 CST for assistance.
	Insufficient power from power outlet.	Make sure the outlet is functional and is the right capacity for the tool.
	Carbon brushes are worn	Inspect and replace carbon brushes as needed (see page 21) Replacement brushes (Model MM1214-114) can be ordered from <a href="http://wenproducts.com">wenproducts.com</a> .
	Defective motor or other internal problem	Stop using the tool and contact customer service at (800) 232-1195, M-F 8-5 CST for assistance.
Saw overheats	Tool forced to work too fast	Do not force the tool and make sure the workpiece is compatible with the blade in use.
	The extension cord is too long or too thin	See page 8 for selecting the proper size of extension cord for your tool.
	Blocked motor housing vents	Blow dust out of the motor housing vents while wearing safety goggles and dust mask.

# EXPLODED VIEW & PARTS LIST

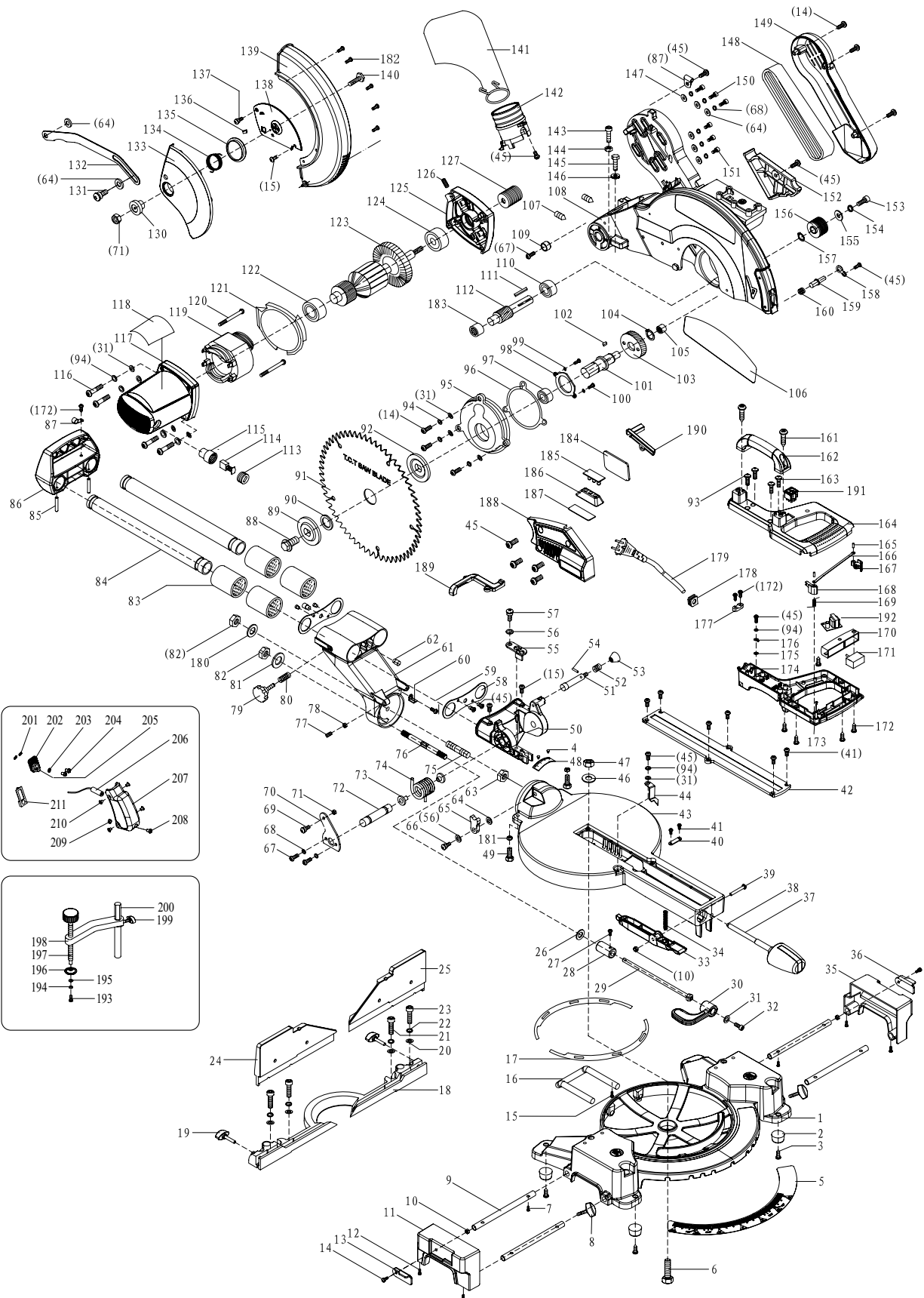

**NOTE:** Not all parts may be available for purchase. Parts and accessories that wear down over the course of normal use are not covered under the warranty.

## EXPLODED VIEW & PARTS LIST

No.	Part. No.	Description	Qty.
1	MM1214-001	Base	1
2	MM1214-002	Foot	4
3	MM1214-003	M4x12 Self-Tapping Screw	4
4	MM1214-004	Ø2x4 Rivet	2
5	MM1214-005	Miter Scale	1
6	MM1214-006	M8x55 Hex Bolt	1
7	MM1214-007	M5x6 Cross Head Screw	2
8	MM1214-008	M6x25 Table Extension Knob	2
9	MM1214-009	Table Extension Rod	4
10	MM1214-010	M5 Lock Nut	3
11	MM1214-011	Table Extension Block (Left)	1
12	MM1214-012	M5x8 Cross Head Screw	4
13	MM1214-013	Left Table Extension Stop Plate	1
14	MM1214-014	M5x20 Cross Head Screw	9
15	MM1214-015	M6x10 Cross Head Screw	4
16	MM1214-016	Anti-Tip Support	1
17	MM1214-017	Swivel Plate	2
18	MM1214-018	Fence	1
19	MM1214-019	M6x32 Knob	2
20	MM1214-020	M8 Flat Washer	4
21	MM1214-021	M8x25 Hex Screw	2
22	MM1214-022	M8 Spring Washer	4
23	MM1214-023	M8x35 Hex Screw	2
24	MM1214-024	Left Fence Extension	1
25	MM1214-025	Right Fence Extension	1
26	MM1214-026	M12 Washer	1
27	MM1214-027	M5x10 Cross Head Screw	1
28	MM1214-028	Lock Nut	1
29	MM1214-029	Locking Rod	1
30	MM1214-030	Bevel Lock Lever	1
31	MM1214-031	M5 Flat Washer	9
32	MM1214-032	M5x10 Hex Screw	1
33	MM1214-033	Miter Detent Lever	1
34	MM1214-034	Compression Spring	1

No.	Part. No.	Description	Qty.
35	MM1214-035	Table Extension Block (Right)	1
36	MM1214-036	Right Table Extension Stop Plate	1
37	MM1214-037	Miter Lock Knob	1
38	MM1214-038	Miter Lock Knob Washer	1
39	MM1214-039	M5x35 Socket Head Screw	1
40	MM1214-040	Small Press Board	1
41	MM1214-041	M4x8 Cross Head Screw	8
42	MM1214-042	Kerf Board	1
43	MM1214-043	Table	1
44	MM1214-044	Miter Angle Indicator	1
45	MM1214-045	M5x10 Cross Head Screw	17
46	MM1214-046	M8 Flat Washer	1
47	MM1214-047	M8 Lock Nut	2
48	MM1214-048	Bevel Scale	1
49	MM1214-049	M8x20 Hex Screw	2
50	MM1214-050	Bevel Hinge	1
51	MM1214-051	Lock-Down Pin	1
52	MM1214-052	Lock-Down Spring	1
53	MM1214-053	Lock-Down Pin Head	1
54	MM1214-054	Ø3x16 Spring Cylindrical Pin	1
55	MM1214-055	Depth Stop	1
56	MM1214-056	M8 Wavy Washer	2
57	MM1214-057	M8 Pan Head Bolt	1
58	MM1214-058	Bearing Cover	2
59	MM1214-059	M4x10 Cross Head Screw	1
60	MM1214-060	Bevel Angle Indicator	1
61	MM1214-061	Table Support	1
62	MM1214-062	Stop Pin	2
63	MM1214-063	M10 Hex Nut	1
64	MM1214-064	M6 Flat Washer	8
65	MM1214-065	Bevel Stop Block	1
66	MM1214-066	M6x16 Non-Standard Screw	1
67	MM1214-067	M6x14 Cross Head Screw	3



## EXPLODED VIEW & PARTS LIST

No.	Part. No.	Description	Qty.
68	MM1214-068	M6 Spring Washer	8
69	MM1214-069	M6x10 Cross Bolt	1
70	MM1214-070	Connecting Bar Support	1
71	MM1214-071	M6 Lock Nut	2
72	MM1214-072	Hinge Pin	1
73	MM1214-073	Spring Sleeve	2
74	MM1214-074	Torsion Spring	1
75	MM1214-075	M10x80 Stud	1
76	MM1214-076	Locking Rod	1
77	MM1214-077	M8x25 Zero Stop Screw	1
78	MM1214-078	M8 Zero Stop Lock Nut	1
79	MM1214-079	M6x25 Slide Lock Knob	1
80	MM1214-080	Spring	1
81	MM1214-081	M10xM28x3 Flat Washer	1
82	MM1214-082	M10 Lock Nut	1
83	MM1214-083	Ø45xØ30x35 Linear Bearing	4
84	MM1214-084	Slide Rail	2
85	MM1214-085	Ø5x44 Roll Pin	2
86	MM1214-086	Slide Rail Cover	1
87	MM1214-087	Cable Clamp	2
88	MM1214-088	M8x18 Arbor Screw (Left)	1
89	MM1214-089	Outer Flange	1
90	MM1214-090	Arbor Insert	1
91	MM1214B	TCT 12 in. Blade	1
92	MM1214-092	Inner Flange	1
93	MM1214-093	M5x40 Cross Pan Head Screw	2
94	MM1214-094	M5 Spring Washer	9
95	MM1214-095	Gearbox Cover	1
96	MM1214-096	Gasket	1
97	MM1214-097	6003 Bearing	1
98	MM1214-098	Bearing Retainer	1
99	MM1214-099	M4 Spring Washer	2
100	MM1214-100	M4x12 Cross Head Screw	2
101	MM1214-101	Spindle	1
102	MM1214-102	Flat Key 4x4x8	1
103	MM1214-103	Large Gear	1
104	MM1214-104	Ø15 Retaining Ring	1

No.	Part. No.	Description	Qty.
105	MM1214-105	Roller Bearing HK1010	1
106	MM1214-106	Guard Label	1
107	MM1214-107	M6x10 Set Screw	2
108	MM1214-108	Upper Blade Guard	1
109	MM1214-109	Upper Blade Guard Bushing	1
110	MM1214-110	6001 Bearing	1
111	MM1214-111	Flat Key 4x4x20	1
112	MM1214-112	Gear Shaft	1
113	MM1214-113	Brush Holder Cap	2
114	MM1214-114	Carbon Brush	2
115	MM1214-115	Brush Holder	2
116	MM1214-116	M5x35 Cross Head Screw	4
117	MM1214-117	Motor Housing	1
118	MM1214-118	Motor Housing Label	1
119	MM1214-119	Stator	1
120	MM1214-120	ST4.8x65 Self-Tapping Screw	2
121	MM1214-121	Seal	1
122	MM1214-122	6000 Bearing	1
123	MM1214-123	Rotor	1
124	MM1214-124	6002 Bearing	1
125	MM1214-125	Middle Cover	1
126	MM1214-126	M8x25 Set Screw	1
127	MM1214-127	Small Pulley	1
130	MM1214-130	Lower Blade Guard Washer	1
131	MM1214-131	Connecting Bar Screw	1
132	MM1214-132	Connecting Bar	1
133	MM1214-133	Lower Blade Guard Panel	1
134	MM1214-134	Lower Blade Guard Coil Spring	1
135	MM1214-135	Lower Blade Guard Washer	1
136	MM1214-136	Rubber Stopper	1
137	MM1214-137	M6x7 Flat Head Bolt	1
138	MM1214-138	Guard Plate	1
139	MM1214-139	Lower Blade Guard	1
140	MM1214-140	M6x14 Hex Screw	1
141	MM1214-141	Dust Collection Bag	1

## EXPLODED VIEW & PARTS LIST

No.	Part. No.	Description	Qty.
142	MM1214-142	Dust Outlet	1
143	MM1214-143	M6x25 Hex Screw	2
144	MM1214-144	M6 Hex Nut	2
145	MM1214-145	M6x35 Hex Screw	1
146	MM1214-146	Depth Adjustment Nut	1
147	MM1214-147	M6 Flat Washer	1
148	MM1214-148	Belt (10PJ560)	1
149	MM1214-149	Belt Cover	1
150	MM1214-150	M6x20 Hex Screw	3
151	MM1214-151	M6x16 Hex Screw	3
152	MM1214-152	Cover	1
153	MM1214-153	M6x16 Cap Screw (Left)	1
154	MM1214-154	M6 Spring Washer	1
155	MM1214-155	M6 Thick Flat Washer	1
156	MM1214-156	Large Pulley	1
157	MM1214-157	Ø28 Retaining Ring	1
158	MM1214-158	Spindle Lock Bracket	1
159	MM1214-159	Spindle Lock	1
160	MM1214-160	Spindle Lock Taper Spring	1
161	MM1214-161	ST6x18 Screw	2
162	MM1214-162	Handle	1
163	MM1214-163	M5x50 Cross Pan Head Bolt	2
164	MM1214-164	Upper Handle	1
165	MM1214-165	Pin	2
166	MM1214-166	Trigger Lock Connector	1
167	MM1214-167	Right Trigger Lock	1
168	MM1214-168	Left Trigger Lock	1
169	MM1214-169	Switch Torsion Spring	1
170	MM1214-170	Trigger	1
171	MM1214-171	Switch	1
172	MM1214-172	ST3.9x14 Self-Tapping Screw	7
173	MM1214-173	ST3.9x10 Self-Tapping Screw	2
174	MM1214-174	Lower Handle	1
175	MM1214-175	M5 Toothed Washer	1
176	MM1214-176	Terminal	1
177	MM1214-177	Cable Clamp	1
178	MM1214-178	Grommet	1

No.	Part. No.	Description	Qty.
179	MM1214-179	Power Cord	1
180	MM1214-180	M10 Flat Washer	1
181	MM1214-181	M8 Hex Nut	2
182	MM1214-182	M5 Cross Head Screw	5
183	MM1214-183	607 Bearing	1
184	MM1214-184	Cover	1
185	MM1214-185	LED Light	1
186	MM1214-186	Reflecting Board	1
187	MM1214-187	Transparent Panel	1
188	MM1214-188	LED Light Cover	1
189	MM1214-189	LED Wire Cover	1
190	MM1214-190	Laser Wire Cover	1
191	MM1214-191	Double Switch	1
192	MM1214-192	Transformer PCB	1
<b>Clamp Assembly MM1214-197ASM</b>			
193	MM1214-193	M5x12 Cross Screw	1
194	MM1214-194	M5 Spring Washer	1
195	MM1214-195	M6 Flat Washer	1
196	MM1214-196	Clamp Pressure Plate	1
197	MM1214-197	Clamp	1
198	MM1214-198	Small Connecting Bar	1
199	MM1214-199	M6x20 Knob	1
200	MM1214-200	Clamp Locating Bar	1
<b>Laser Module MM1214-206ASM</b>			
201	MM1214-201	M4 Wavy Washer	2
202	MM1214-202	Laser Seat	1
203	MM1214-203	M3 Flat Washer	2
204	MM1214-204	M3x8 Cross Screw	2
205	MM1214-205	M4x6 Screw	1
206	MM1214-206	Laser	1
207	MM1214-207	Laser Cover	1
208	MM1214-208	M4x14 Screw	1
209	MM1214-209	M4 Nut	1
210	MM1214-210	M4x8 Cross Screw	8
211	MM1214-211	Dust Cover	1

**NOTE:** Not all parts may be available for purchase. Parts and accessories that wear down over the course of normal use are not covered under the warranty.

## **WARRANTY STATEMENT**

WEN Products is committed to building tools that are dependable for years. Our warranties are consistent with this commitment and our dedication to quality.

### **LIMITED WARRANTY OF WEN PRODUCTS FOR HOME USE**

GREAT LAKES TECHNOLOGIES, LLC (“Seller”) warrants to the original purchaser only, that all WEN consumer power tools will be free from defects in material or workmanship during personal use for a period of two (2) years from date of purchase or 500 hours of use; whichever comes first. Ninety days for all WEN products if the tool is used for professional or commercial use. Purchaser has 30 days from the date of purchase to report missing or damaged parts.

SELLER’S SOLE OBLIGATION AND YOUR EXCLUSIVE REMEDY under this Limited Warranty and, to the extent permitted by law, any warranty or condition implied by law, shall be the replacement of parts, without charge, which are defective in material or workmanship and which have not been subjected to misuse, alteration, careless handling, misrepair, abuse, neglect, normal wear and tear, improper maintenance, or other conditions adversely affecting the Product or the component of the Product, whether by accident or intentionally, by persons other than Seller. To make a claim under this Limited Warranty, you must make sure to keep a copy of your proof of purchase that clearly defines the Date of Purchase (month and year) and the Place of Purchase. Place of Purchase must be a direct vendor of Great Lakes Technologies, LLC. Purchasing through third party vendors, including but not limited to garage sales, pawn shops, resale shops, or any other secondhand merchant, voids the warranty included with this product. Contact [techsupport@wenproducts.com](mailto:techsupport@wenproducts.com) or 1-800-232-1195 with the following information to make arrangements: your shipping address, phone number, serial number, required part numbers, and proof of purchase. Damaged or defective parts and products may need to be sent to WEN before the replacements can be shipped out.

Upon the confirmation of a WEN representative, your product may qualify for repairs and service work. When returning a product for warranty service, the shipping charges must be prepaid by the purchaser. The product must be shipped in its original container (or an equivalent), properly packed to withstand the hazards of shipment. The product must be fully insured with a copy of the proof of purchase enclosed. There must also be a description of the problem in order to help our repairs department diagnose and fix the issue. Repairs will be made and the product will be returned and shipped back to the purchaser at no charge for addresses within the contiguous United States.

THIS LIMITED WARRANTY DOES NOT APPLY TO ITEMS THAT WEAR OUT FROM REGULAR USAGE OVER TIME, INCLUDING BELTS, BRUSHES, BLADES, BATTERIES, ETC. ANY IMPLIED WARRANTIES SHALL BE LIMITED IN DURATION TO TWO (2) YEARS FROM DATE OF PURCHASE. SOME STATES IN THE U.S. AND SOME CANADIAN PROVINCES DO NOT ALLOW LIMITATIONS ON HOW LONG AN IMPLIED WARRANTY LASTS, SO THE ABOVE LIMITATION MAY NOT APPLY TO YOU.

IN NO EVENT SHALL SELLER BE LIABLE FOR ANY INCIDENTAL OR CONSEQUENTIAL DAMAGES (INCLUDING BUT NOT LIMITED TO LIABILITY FOR LOSS OF PROFITS) ARISING FROM THE SALE OR USE OF THIS PRODUCT. SOME STATES IN THE U.S. AND SOME CANADIAN PROVINCES DO NOT ALLOW THE EXCLUSION OR LIMITATION OF INCIDENTAL OR CONSEQUENTIAL DAMAGES, SO THE ABOVE LIMITATION OR EXCLUSION MAY NOT APPLY TO YOU.

THIS LIMITED WARRANTY GIVES YOU SPECIFIC LEGAL RIGHTS, AND YOU MAY ALSO HAVE OTHER RIGHTS WHICH VARY FROM STATE TO STATE IN THE U.S., PROVINCE TO PROVINCE IN CANADA AND FROM COUNTRY TO COUNTRY.

THIS LIMITED WARRANTY APPLIES ONLY TO ITEMS SOLD WITHIN THE UNITED STATES OF AMERICA, CANADA AND THE COMMONWEALTH OF PUERTO RICO. FOR WARRANTY COVERAGE WITHIN OTHER COUNTRIES, CONTACT THE WEN CUSTOMER SUPPORT LINE. FOR WARRANTY PARTS OR PRODUCTS REPAIRED UNDER WARRANTY SHIPPING TO ADDRESSES OUTSIDE OF THE CONTIGUOUS UNITED STATES, ADDITIONAL SHIPPING CHARGES MAY APPLY.

**THANKS FOR  
REMEMBERING**  <sup>®</sup>