



iSpring Whole House Ultraviolet Light Water Filter

Installation and Maintenance Manual

Model UVF55FS



Please read the User's Manual Carefully and keep it available

Overview

UV has proven to be a quick, reliable, and cost-effective method of water treatment for both point-of-use (POU) and point-of-entry (POE) systems. Being a chemical-free, environmentally friendly, and affordable UV water filter system, iSpring's upgraded UVF55FS UV water filter can protect the whole house against water concerns commonly found in private wells. For houses that get water from municipal water suppliers, this UV light water filter provides an effective solution against chlorine-resistant substances so that you know you and your loved ones get clean and worry-free water for drinking, washing, showers and more.

Build your trust in water for your entire household by removing risks unable to be addressed by your municipal treatment plant or those born with well water or other natural water sources. This whole house UV light water filter is a perfect last step to add to your whole house water filtration system and give you the peace of mind of knowing you can trust your water.

Table of Content

Overview/Table of Content-----	1
Components in thePackage -----	2
Precautions-----	3
Specs and Conditions-----	3
Installation-----	4
System Operation-----	9
Maintenance -----	10
Trouble Shooting-----	11
Warranty-----	12
Warranty Registration-----	14
Contact Us-----	14

Components in the Package

Model: UVF55FS

POE/POU:POE(Point of Entry)

Input: 110-120V 50/60Hz

UV Bulb: Model#UVB55FS

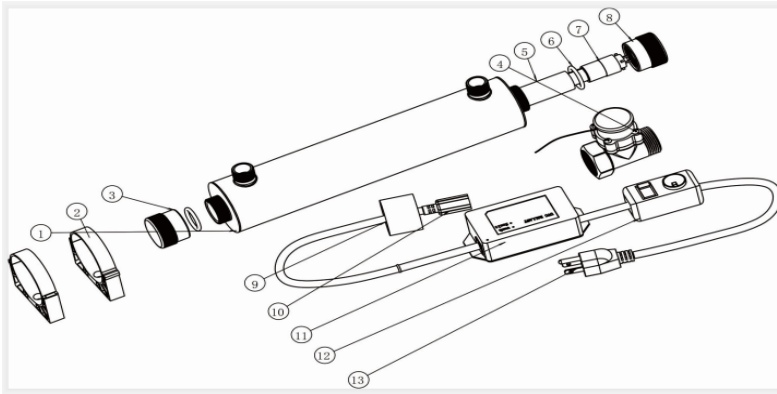

1.Filter chamber(304SS)

2. Clamps

3. Nut

4. Flow switch

5. Quartz tube

6. O-rings

7. UV Lamp

8. Open-end nut

9. Cover Cap

10. UV lamp socket

11. Electronic ballast

12. Control Switch

13. Plug

Reminders

- Please do not install this product outside or at a place where it is exposed to direct sunlight or freezing temperature.
- Please install this product at a place where it is easy to access and maintain.
- Avoid jarring/bumping, freezing, overheating and corrosive chemicals.

Specs and Conditions

Operating Parameters	
Maximum Operating Pressure	85psi
Minimum Operating Pressure	4psi
Maximum Ambient Air Temperature	100°F
Minimum Ambient Air Temperature	32°F
Maximum Humidity	100%
Maximum Hardness	120ppm
Maximum Iron	0.3ppm
Minimum UVT	70%
Installation	Vertical or horizontal
Rated Flow	UVF55FS – 12GPM
Rated Service life of the lamp	1 Year

Installation

Before Installation

- The unit comes with two ports. Both are 1-inch MNPT and can be used as an inlet or outlet. Please choose the correct fittings to fit your plumbing. For easy maintenance, it is recommended that you install an inlet valve and an outlet valve before and after the unit. Please make sure that it can be easily disassembled from the water line for future maintenance.
- The unit should be installed after a sediment filter, as sediments in the water can block UV light and become a shelter for germs. Thus, water coming into the UV filter must be clear (free of particles larger than 20 microns). It is recommended that you install the UV filter after the filters as the last stage.
- If water flow speed exceeds rated flow, please install a flow-limiting or pressure-limiting device. If the water pressure is over 43 psi, please install a pressure regulator in the inlet/outlet in order to protect the quartz sleeve.
- Please install the filter at a position by the retaining clip, retaining nuts or other mounting device in order to prevent it from dropping due to the vibration caused by water and causing damages to the internal fragile parts.
- The ultraviolet water filter is not a water filter. It is unable to eliminate bad tastes or smells, biological materials, chemicals, silt, heavy metal and other kinds of impurities, and it does not reduce sediments which affects the efficiency of the UV lamp. Therefore, it is necessary to install a pre-filter to ensure that the filter can achieve optimal performance.

Installation Steps

Step1 - Before mounting the two black plastic clips onto the wall, make sure there is enough room for both the stainless-steel housing and access for future servicing. It can be installed horizontally or vertically. (If you choose vertical mounting, make sure that water inlet is mounted at a lower level while the outlet is at a higher level to slow down water flow and increase exposure to the UV light.

Step2—Open the package to check all components inside: Filter Chamber, UV Lamp, Quartz Tube, O-rings, Electronic Ballast, Clamps, Flow switch. Make sure that the Quartz Tube and UV Lamp are clean before installation (clean it with alcohol or mild detergent). Wear soft non-abrasive gloves to keep any finger marks away from them.

Step3—Remove both Open and Closed End Nut from filter Chamber.

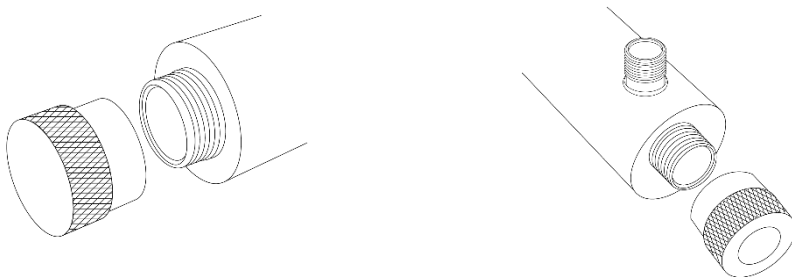

Step4—Install O-ring onto the open end of Quartz Tube (12mm from the edge).

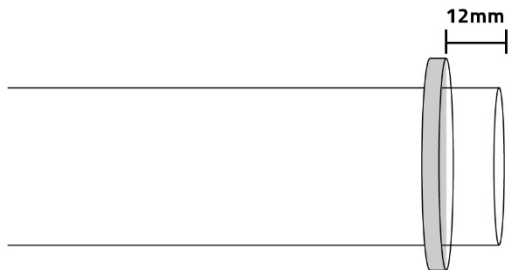

Step 5—Insert the quartz tube into the Filter chamber.

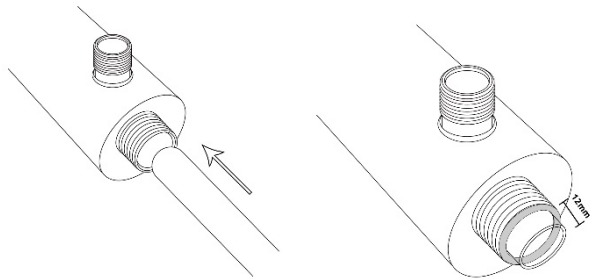

Step 6—Install O-ring onto the closed end of the quartz tube.

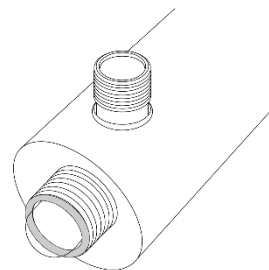

Step 7—Hand-screw closed end nut on the filter chamber (closed end of quartz tube). To protect the O-ring, do not over tighten.

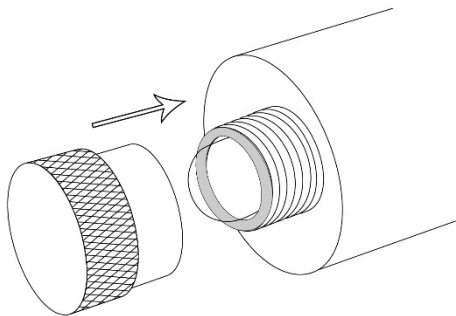

Step 8—Hand-screw open end nut on the filter chamber (open end of quartz tube). To protect the O-ring, do not over tighten.

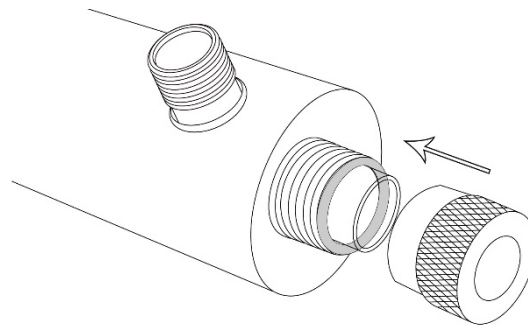

Step 9—Connect 4-pin electrical socket with UV lamp pins tightly.

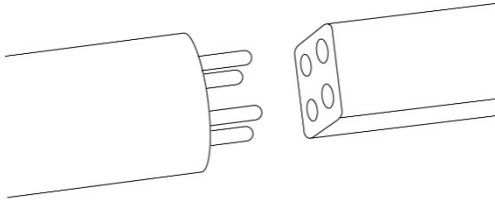

Step 10—Carefully insert the UV lamp into the quartz tube through open end nut.

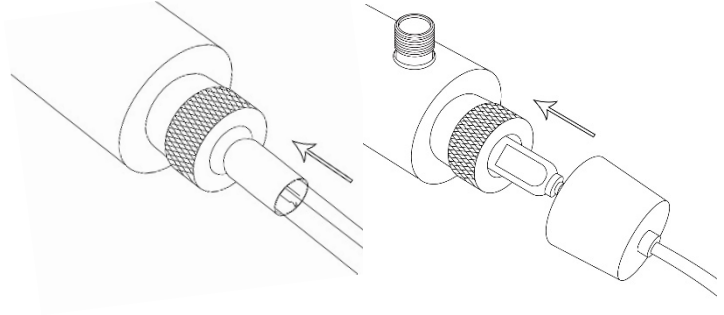

Step 11—Install the cover cap and hand-tighten onto open End Nut.

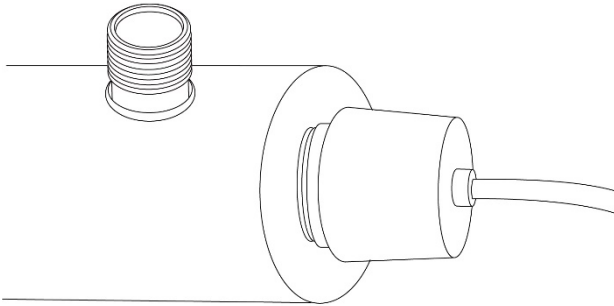

Step 12—Insert the flow switch on the outlet, please notice the water flowing direction.

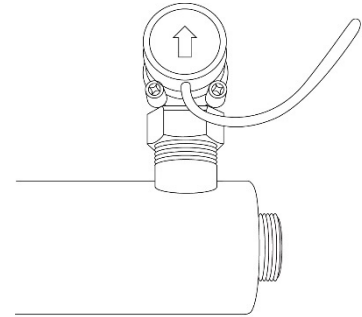

Step 13—Connect flow switch cable with control switch, close the switch cover.

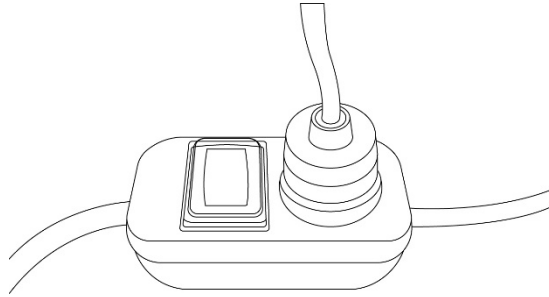

Step 14—Push control switch to button “AUTO”, the UV lamp will start working automatically when there is only water flowing. Push control switch to button “MOVE”, the UV lamp keeps working continuously. Push control switch button “STOP” to turn off the UV lamp. Mode AUTO is highly recommended to protect the UV lamp.

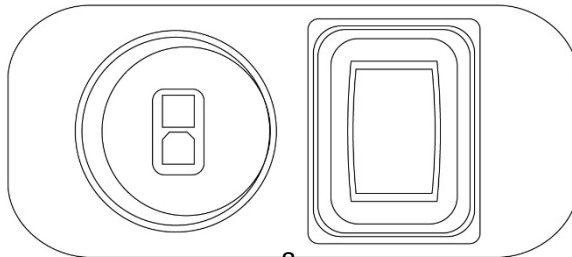

Step 15–Select a readily accessible and well lit location to fix the system. The system should always be located close to the point of use and can either be installed horizontally or vertically.

Step 16–When all plumbing connections are finished, slowly turn on the water supply and check for leaks.

Step 17–Allow the water to run for a few minutes to clear any air or dust that may be in the filter chamber.

Step 18–Connect the power for starting up.

System Operation

Water Quality Guidelines

- A. The ultraviolet water filter is intended for the use with visually clear water, not colored, cloudy or turbid.
 - ◆ Ambient Water Temperature: 2-45°C
 - ◆ Iron: <0.3ppm (0.3mg/l)
 - ◆ Hardness: <7gpg (120mg/l)
 - ◆ Turbidity: <1NTU
 - ◆ Manganese: 0.05ppm (0.05mg/l)
 - ◆ UV Transmittance: >75%
- B. Recheck the installation before plug the filter into power.
- C. Do not proceed to install the equipment when UV Lamp or Sleeve Tube is broken, buy one again and continue.
- D. Ultraviolet Disinfection System is designed for continuous operation and frequent switching will reduce Ultraviolet radiation and service life.
- E. If this unit falls into the water, turn mainpower off and then retrieve it. Do not attempt to use this filter if it has been submerged.
- F. Donot operate this unit if it has a damaged cord or plug, if it is malfunctioning or if it has beendropped or been damaged in any manner.

- G. The UV system should be installed after the filter on the return line.

Always disconnect the water supply and completely drain the water purifier if it will be subjected to temperatures below freezing for extended periods of time.

Maintenance

- **For your safety, ALWAYS wear goggles and turn the power OFF before REPLACING the UV lamp or CLEANING the quartz sleeve! Servicing the unit with power on will also cause damage to the ballast. Never service the UV lamp or quartz sleeve without wearing protective eyewear!**
- Over time, minerals in the water slowly form a coating on the quartz sleeve. This coating must be removed periodically, as it reduces the amount of UV light reaching the water. **Please carefully clean the lamp and quartz sleeve at least 3 times a year if the unit can be unmounted easily. Otherwise, please replace the lamp and quartz sleeve every 1-2 years.**
- To clean the lamp—Wear rubber, latex or nitrile gloves to avoid contaminating the lamp.
 - Unplug the power, shut off both inlet and outlet valves, and remove the entire housing from the water line. Next, drain the water and remove the black rubber cap which has the power cord attached, then remove the lamp from the quartz sleeve. Wipe the lamp with a piece of lint free cloth moistened with white vinegar.
- To clean the quartz sleeve—Use great care when handling the quartz sleeve as it is very fragile; avoid bumping or jarring it.
 - Unplug the power, shut off both inlet and outlet valves, and remove the entire housing from the water line. Next, drain the water and remove the black rubber cap which has the power cord attached, then remove the lamp from the

quartz sleeve. Pour vinegar into the water inlet and soak the quartz sleeve until it is clear. Rinse thoroughly and carefully.

- The UVF55FS is designed to operate continuously and should not be switched on and off frequently.

The UVF11 series come with a flow sensor that turns the UV unit on and off automatically with water flow.

- The amount of UV light created by the lamp decreases over time, therefore the lamp should be replaced every 12 months.

Troubleshooting

Symptom	Solution
Leaking from the UV filter steel pipe nuts	The O-ring inside the quartz sleeve might be damaged. Please contact us for assistance
Leaking from the quartz sleeve	Replace the quartz sleeve
Leaking at the inlet/outlet	Wrap Teflon tape on the threads and reconnect the water pipe
Ballast alarm goes off; green indicator light is out, and the lamp doesn't power on	Lamp has exhausted its service life, replace the lamp
Lamp doesn't turn on after replacing	Check the lamp connector wires
Lamp turns on but indicator lights and alarm are abnormal	Indicator lights are broken, replace the ballast

Warranty

This Limited Warranty extends to the original purchaser of the system only. This warranty only covers all Manufacturer-supplied items that prove to be defective in material, workmanship, or factory preparation. This warranty covers parts only; all labor is excluded from this warranty, including, but not limited to, services related to the removal, replacement, installation, adjustment, maintenance, and/or repair of the unit or its component items. Excludes all non-Manufacturer labor required for any servicing of the unit, including, but not limited to, servicing related to installation, adjustment, maintenance, and repair of the unit. This warranty applies only for the first full calendar year from date of purchase. The following items are excluded from this warranty: UV lamp, and the quartz sleeve that require regular replacement as a result of ordinary usage.

Disclaimers: This Limited Warranty applies only if the system is installed, used, and maintained in compliance with all instructions and requirements enclosed with the system. This warranty will be void for failure to observe the following conditions:

1. The system is to be used with potable water supply only.
2. Feed water pressure to the unit is no less than 4 PSI and no greater than 85 PSI.
3. The system is to be used on water supplies with chlorine concentrations of 1.0 mg/L (ppm) or less.
4. Feed water temperature to the unit must be no less than 32°F and no more than 100°F.
5. Maximum hardness in feed water must be less than 120ppm.
6. Feed water must have a pH between 4 and 8.
7. Turbidity must be less than 1.0 NTU.
8. SDI must be less than 5.
9. Maximum iron in feed water must be less than 0.3ppm.

While the testing was performed under standard laboratory conditions, actual performance may vary. The Manufacturer does not know the characteristics of your water supply. The quality of water supplies may vary seasonably, or over a period of time. Your water usage may vary as well. The Manufacturer assumes no liability for the determination of the proper equipment necessary to meet your requirements, and we do not authorize others to assume such obligation on our behalf.

This Limited Warranty does not cover any Manufacturer-supplied items that are defective as a result of the use of improper parts, equipment or materials. This warranty does not cover alterations or modifications of the unit or failure of a unit caused by such alterations and modifications.

This Limited Warranty does not cover malfunctions of the unit due to tampering, misuse, alteration, lack of regular maintenance, misapplication, fouling due to hydrogen sulfide, manganese or iron, scaling from excessive hardness, turbidity greater than 1.0 NTU, Silt

Density Index (SDI) greater than 5.0. In addition, damage to the unit due to fire, accident, negligence, acts of God, or events beyond the control of the Manufacturer are not covered by this warranty.

Incidental and Consequential Damages Limitation: The Manufacturer will not be responsible for any incidental or consequential damages as a result of the failure of this unit to comply with express or implied warranties or any defect in the unit, including but not limited to, lost time, inconvenience, damage to personal property, loss of revenue, commercial losses, postage, travel, telephone expenditures, or other losses of this nature. In case some states do not allow the exclusion or limitation of incidental or consequential damages, you may choose to return the system. If you choose to keep it, you understand this exclusion WILL STILL apply to you.

Owner's Warranty Responsibilities: As a condition of this Limited Warranty, the owner must ensure that periodic maintenance of the system is performed as described in the literature enclosed with the system. Neglect, improper maintenance, abuse, modification, or alteration of the unit will invalidate this Warranty. Should your unit develop a defect or otherwise fail to perform in accordance with this warranty, you should contact the retailer from whom the product was originally purchased.

Implied Warranties: The implied at-law warranties of merchantability and fitness for a particular purpose shall terminate on the date one year after the date of purchase.

NOTE: IN CASE SOME STATES DO NOT ALLOW LIMITATIONS ON HOW LONG AN IMPLIED WARRANTY LASTS, YOU MAY CHOOSE TO RETURN THE SYSTEM. IF YOU CHOOSE TO KEEP IT, YOU AGREE THAT THE ABOVE LIMITATIONS STILL APPLY TO YOU.

Warranty Registration

To register your product for the warranty, please visit our website at 123filter.com and go to the “Warranty Registration” tab. We provide a 30-day money back guarantee, a 1-year manufacturer warranty, and lifetime tech support for all of our products. However, we do not have the order information from websites other than 123Filter.com (Amazon, Home Depot, etc.), so please be sure to fill in that information upon registration of your system. If you have any questions or concerns about your product, please do not hesitate to call or email us. You may always insert notes/comments upon your warranty registration. Your satisfaction is our business!

If you are happy with our products and service, please show your support by writing a product review on Amazon--even just a single line. It takes you just a minute but means a lot to us. Thank you.

How To Contact Us

Office Hours: Monday-Friday 9:00 a.m. - 5:00 p.m. EST

Phone: (678) 261-7611

Email: support@ispringfilter.com



iSpring Water Systems, LLC

Atlanta, Georgia, USA