

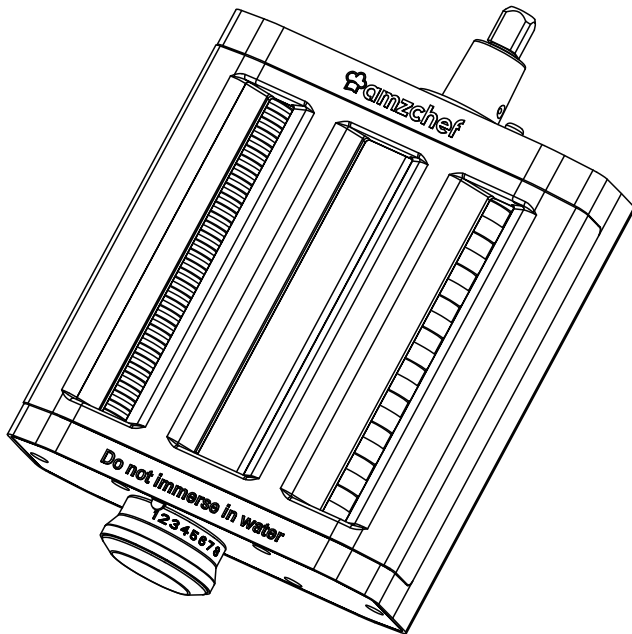

INSTRUCTION MANUAL

3 IN 1 PASTA MAKER ATTACHMENT



Model No.:DT-10-A

PLEASE READ INSTRUCTIONS CAREFULLY BEFORE ASSEMBLY
RETAIN THIS MANUAL FOR FUTURE REFERENCE

Contents

PART AND FEATURES	1
PASTA ROLLER AND CUTTER SAFETY.....	2
USING THE PASTA ROLLER AND CUTTERS	3-8
CARE AND CLEANING	9
RECIPE	10
TROUBLESHOOTING	11
WARRANTY.....	12

PARTS AND FEATURES

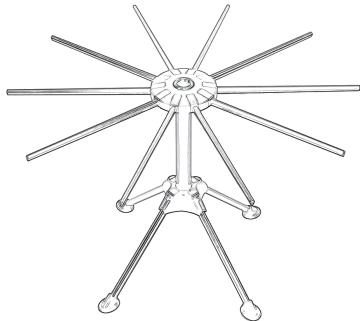
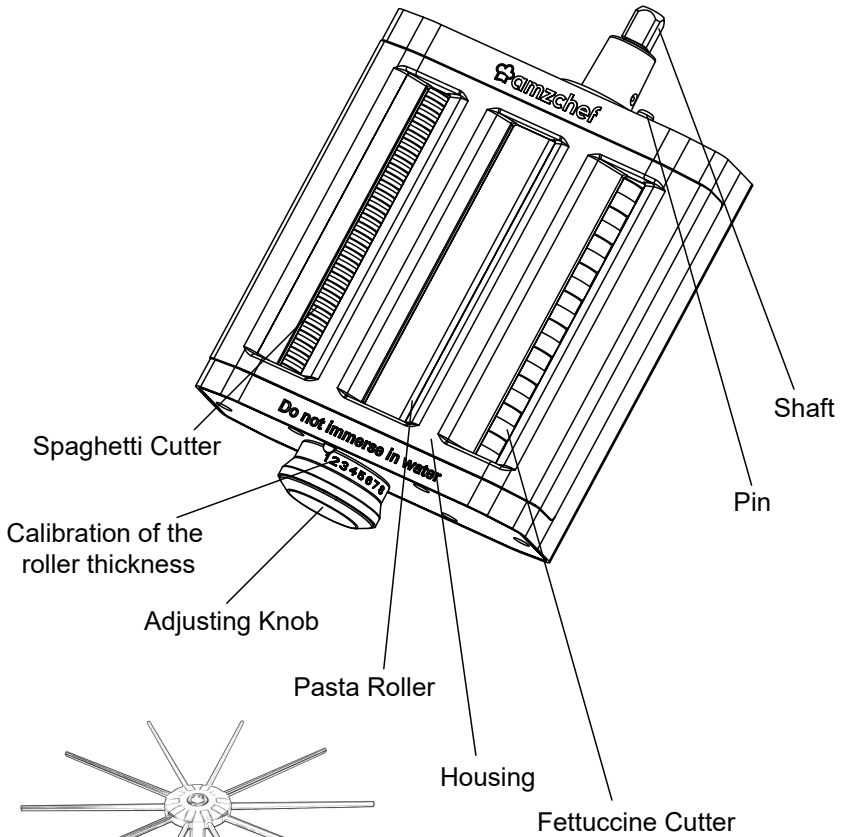

Pasta Dryer

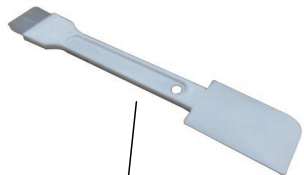

Cleaning Brush

PASTA ROLLER AND CUTTERS SAFETY

Your safety and the safety of others are very important.

We have provided many important safety messages in this manual and on your appliance. Always read and obey a safety messages.



This is the safety alert symbol.

This symbol alerts you to potential hazards that can kill or hurt you and others.

All safety messages will follow the safety alert symbol and either the word "DANGER" or "WARNING".

These words mean:



You can be killed or seriously injured if you don't immediately follow instructions.



You can be killed or seriously injured if you don't follow instructions.

All safety messages will tell you what the potential hazard is, tell you how to reduce the chance of injury and tell you what can happen if the instructions are not followed.

IMPORTANT SAFEGUARDS

When using electrical appliances, basic safety precautions should always be followed, including the following:

1. Read all instructions.
2. To protect against risk of electrical shock, do not put Stand Mixer in water or other liquid.
3. Close supervision is necessary when this or any appliance is used near children.
4. Unplug and Stand Mixer from outlet when not in use, before putting on or taking off parts, and before cleaning.
5. Avoid contacting moving parts, Keep fingers out of discharge opening.



6. Do not operate the Stand Mixer with a damaged cord or plug or after the Stand Mixer malfunctions, or is dropped or damaged in any manner. Return the Stand Mixer to the nearest Authorized Service for examination, repair or electrical or mechanical adjustment.
7. The use of attachments not recommended or sold by KitchenAid may cause fire, electric shock or injury.
8. Do not use the Stand Mixer outdoors.
9. Do not let the Stand Mixer cord hang over the edge of table or counter.
10. Do not let the Stand Mixer cord contact hot surfaces, including the stove.
11. Also see Important Safeguards included in the Stand Mixer Instructions manual.

SAVE THESE INSTRUCTIONS

This product is designed for household use only.

USING THE PASTA ROLLER AND CUTTERS

SPEED SETTINGS CHART

ATTACHMENT	SPEED	NOODLE WIDTH	SUGGESTED USES
PASTA ROLLER 	2	up to 130mm	See roller settings chart
FETTUCCINE CUTTER 	2	1.9mm	Thick Noodles
SPAGHETTIE CUTTER 	2	6.5mm	Egg Noodles Fettuccine

USING THE PASTA ROLLER AND CUTTERS

ROLLER SETTINGS CHART

PASTA ROLLER	ROLLER SETTING	SUGGESTED USES
	1 or 2	Kneading and thinning dough
	3	Thick "Kluski"- type noodles
	4	Egg noodles
	4 or 5	Lasagna noodle, fettuccine spaghetti and ravioli
	6 or 7	Tortellini, thin fettuccine and linguini fini
	7 or 8	Very thin "angel-hair"-type pasta/capellini or very fine linguine

ATTACHING THE PASTA ROLLER AND CUTTERS

Before first use

To avoid damage, do not wash or immerse attachments in water or other liquid. Do not wash in dishwasher.

Note: These attachments are designed to be used with pasta dough only. To avoid damaging your Pasta Roller, do not cut or roll anything other than pasta.

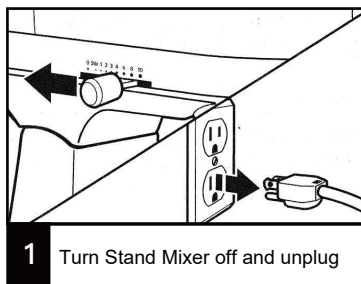

2

For Stand Mixers with a hinged attachment hub cover: Flip up to open.

For Stand Mixers with a removable attachment hub cover: Turn the attachment knob counterclockwise to remove attachment hub cover.

USING THE PASTA ROLLER AND CUTTERS

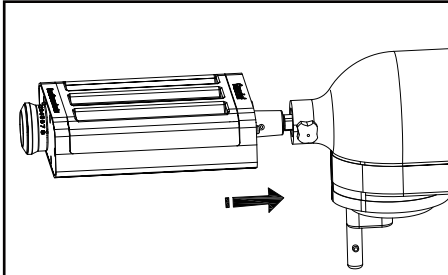

3

Insert attachment shaft housing into the attachment hub, making certain the power shaft fits into the square hub socket. If necessary, rotate the Pasta Roller or Cutter back and forth. The pin on the attachment housing fits into the notch of the hub rim when in the proper position.

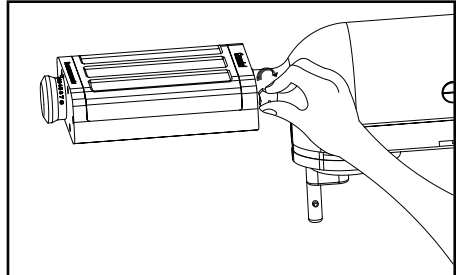

4

Tighten the Stand Mixer attachment hub knob until the attachment is completely secured to the Stand Mixer.

MAKING PASTA

IMPORTANT: When using the Pasta Roller and Cutters, do not wear ties, scarves, loose clothing or long necklaces; gather long hair with a clasp.

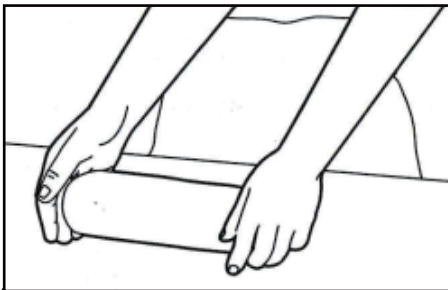

1

Prepare pasta dough (see "Recipe" section). Cut dough into sections that fit in the Pasta Roller

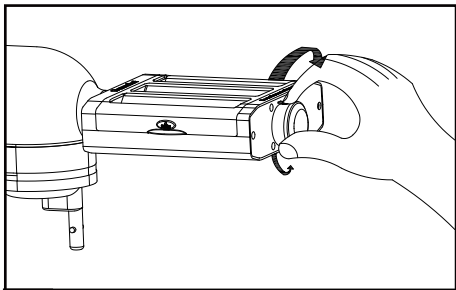

2

Pull the Pasta roller adjustment knob straight out and turn to setting 1. Release the knob, making certain the pin on the Pasta roller housing engages the opening on the back of the adjustment knob, allowing the knob to fit flush against the roller housing.

USING THE PASTA ROLLER AND CUTTERS

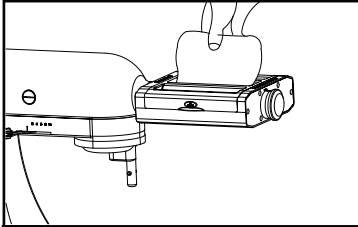

3

Turn Stand Mixer to speed 2. Feed flattened dough into rollers to knead. Fold dough in half and roll again. Repeat until dough is smooth and pliable and covers the width of the roller. Lightly dust pasta with flour while rolling and cutting to aid in drying and separation.

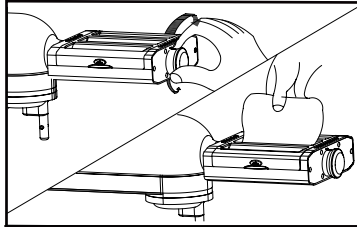

4

Feed dough through rollers to further flatten the sheet of dough. Change the roller to setting 3, and repeat the rolling process. Continue to increase roller setting until desired thickness is reached. Do not fold the dough during this step.

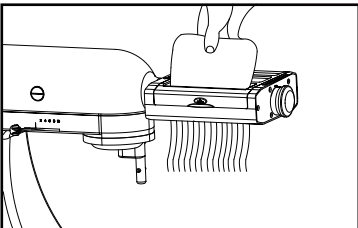

5

To make noodles, exchange the Pasta Roller for the Cutter of your choice. Feed the flattened sheets of dough through the cutter. See the "Roller settings chart" to determine the correct thickness for each type of pasta.

USING THE PASTA ROLLER AND CUTTERS

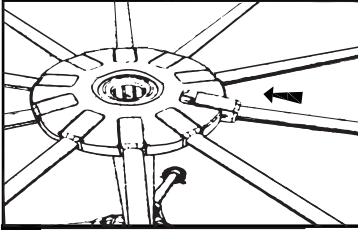

1

When using, lift the pasta holder up to 90 degrees, and then insert it into the slot as shown.

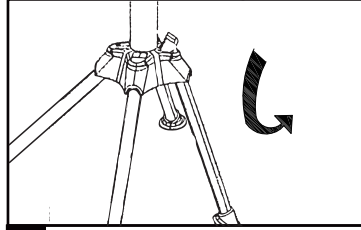

2

Pull the legs up to the right top as shown, and lock it.

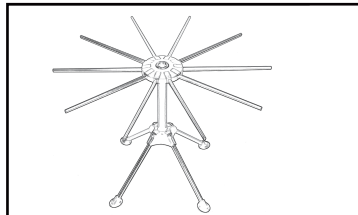

3

Once fully opened, as shown above.

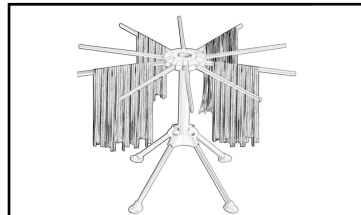

4

After the noodles are pressed, they are placed on the hanging rack to distinguish hanging up without bonding, which is convenient and practical.

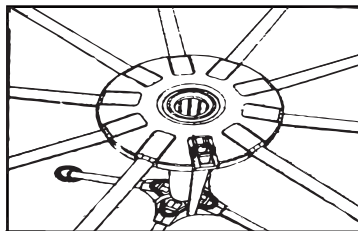

5

When storing, pull out the noodle holder and it can be folded down.

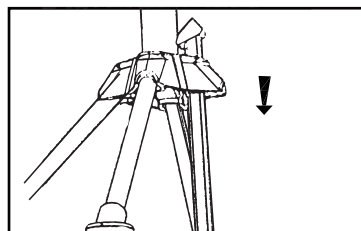

6

Pull the legs down to slot position as shown.

USING THE PASTA ROLLER AND CUTTERS

DISASSEMBLING THE PASTA ROLLER AND CUTTERS

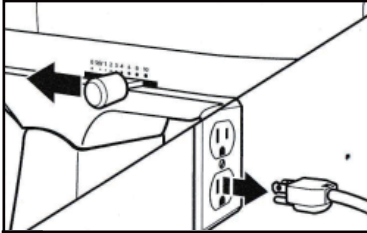

1 Turn Stand Mixer off and unplug.

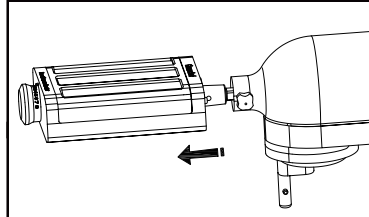

2 Remove the Pasta Roller or Cutter from the Stand Mixer.

IMPORTANT: After removing the Pasta Roller or Cutter from the Stand Mixer, be sure to clean any dried dough. See "Care and Cleaning" for details.

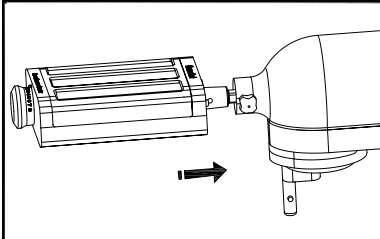

OPTIONAL: If desired, attach the next Pasta Roller or Cutter, using the directions in the "Attaching the Pasta Roller and Cutters" section.

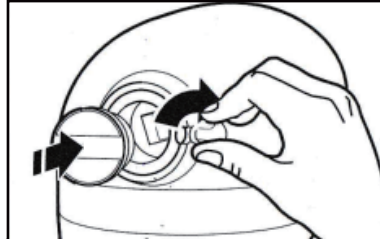

3 After finishing with the Pasta Roller and Cutters replace the hub cover and tighten attachment knob on the Stand Mixer.

NOTE: Allow Stand Mixer to rest for at least 1 hour after extruding 2 consecutive pasta dough recipes.

CARE AND CLEANING

CLEANING THE PASTA ROLLER AND CUTTERS

These accessories are designed to be used with pasta dough only. To avoid damaging your Pasta Roller and Cutters, do not insert anything other than pasta dough.

IMPORTANT: Do not use metal objects to clean out the Pasta Roller and Cutters. Do not wash the Pasta Roller and Cutters in the dishwasher, or immerse in water or other liquids. The Pasta Roller and Cutters should be hand washed.

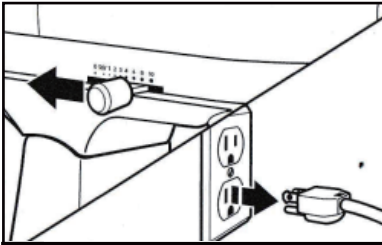

1 Turn Stand Mixer off and unplug.

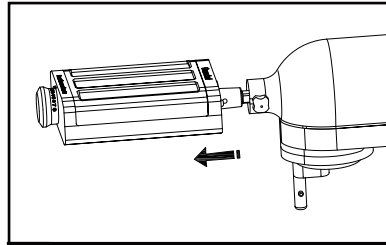

2 Completely disassemble Pasta Roller and Cutters. Use the directions from the "Disassembling the Pasta Roller and Cutters" section.

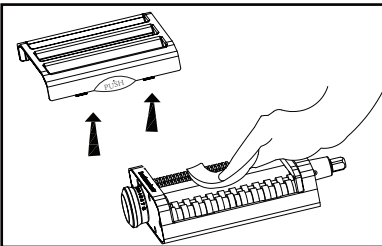

3 After cutting pasta, let Pasta Roller and Cutters air dry for one hour, then remove any dried dough using the Cleaning brush. If dried dough is difficult to remove, try tapping the attachment with your hand. Use a toothpick if necessary.

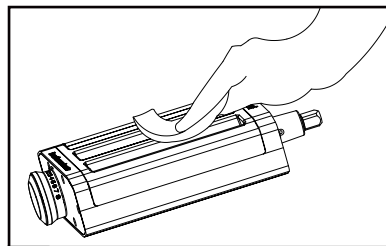

4 After cleaning out all remaining dried dough, polish the Pasta Roller and Cutters with a soft, dry cloth and store in dry place at room temperature. Do not wash the Pasta Roller and Cutters in the dishwasher.

NOTE:

1. Press "PUSH" and flip open to open the lid.
2. Never use a knife or any other sharp object to remove excess dough. Do not run a dish towel or any other cloth through the rollers to clean them.

CARE AND CLEANING

MAINTERNANCE

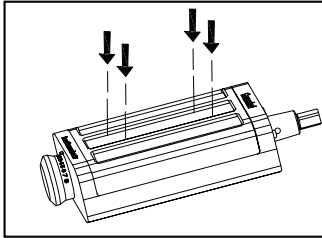

To maintain properly (annually or after 50 uses) we recommend using a light mineral oil to lubricate the gears. Add a drop of mineral oil to each of the 4 corners of the Pasta Roller and Cutters.

RECIPE

COOKING PASTA



WARNING

Food Poisoning Hazard
Do not let foods that contain perishable ingredients such as eggs, dairy products, and meats remain unrefrigerated for more than one hour. Doing so can result in food poisoning or sickness.

Add 2 tsp (10 mL) salt and 1 tbs. (15 mL) oil (optional) to 6 qt (5.7 L) boiling water. Gradually add pasta and continue to cook at a boil until pasta is "al dente" or slightly firm to the bite. Pasta floats to the top of the water while cooking, so stir occasionally to keep it cooking evenly. Use a colander to drain.

Dry Pasta -7 minutes

Fresh Pasta - 2-5 minutes, depending on noodle thickness.

BASIC EGG NOODLE PASTA

4 large eggs
3½ cups (830 mL) sifted all-purpose flour
1 tbs (15 mL) water
1 tsp (2 mL) salt

Break eggs into a glass measuring cup. Check to see that the eggs measure 7/8 cup (207 mL). If less than 7/8 cup (207 mL), add water, 1 tsp (2 mL) at a time, until measurement is reached.

RECIPE

COOKING PASTA



Place flour and salt in Stand Mixer bowl. Attach bowl and flat beater. Turn to Speed 2 and gradually add eggs and 1 tbs (15 mL) water. Mix for 30 seconds. Stop the Stand Mixer and exchange the flat beater for the dough hook. Turn to Speed 2 and knead for 2 minutes.

Let dough rest for 20 minutes.

Divide dough into 4 pieces before processing with Pasta Roller attachment. Follow cooking instructions above.

Yield: About 1 4 pounds (579 a) dough.

TROUBLESHOOTING

 WARNING

<p>Electrical Shock Hazard Plug into a grounded 3 prong outlet. Do not remove ground prong. Do not use an adapter. Do not use an extension cord. Failure to follow these instructions can result in death, fire, or electrical shock.</p>

1. Is the Stand Mixer plugged in?
2. Is the fuse in the circuit to the Stand Mixer in working order? If you have a circuit breaker box, be sure the circuit is closed.
3. Turn off the Stand Mixer for 10-15 seconds, then turn it back on. If the Stand Mixer still does not start, allow it to cool for 30 minutes before turning it back on.
4. Did you use the correct speed for the Pasta Roller and Cutters as suggested in the "Roller Settings Chart"?
5. Did you attach the Pasta Roller or Cutter attachment properly as shown in the "Using the Pasta Roller and Cutters" section?
6. Did you follow the usage instructions as described in the "Using the Pasta Roller and Cutters" section?
7. Is your dough prepared according to the recipe?

If your Stand Mixer should malfunction or fail to operate while using the Pasta Roller and Cutter attachment, please check the following:

If the problem is not due to one of the above items, see the attaching "Warranty Card".



1-YEAR WARRANTY

Thank you for choosing **AMZCHEF** product. We sincerely hope that you are satisfied with it.

This product is warranted against any electronic or mechanical defects for a period of 1 year from the date of original purchase by the consumer. Replacement unit/parts will be warranted for the remaining portion of the original warranty period.

Questions? Problems? Concerns?

If you need any help, please feel free to contact us, via our website: www.iamzchef.com or email: info@iamzchef.com. Problem + Order number+ a photo or a video attached in the email would help us solve the problem better and faster. We will get back to you within 24 hours once we received the email.

