



Use and Care Guide

18 in. Tank Cover for Sewage Basin

Item # 100027541
Model # SF2000E

EVERBILT



TOOLS REQUIRED

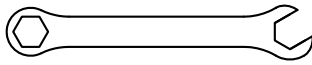

7/16" WRENCH

PACKAGE CONTENTS

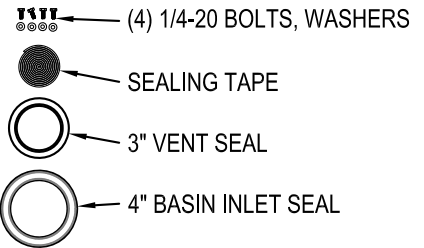
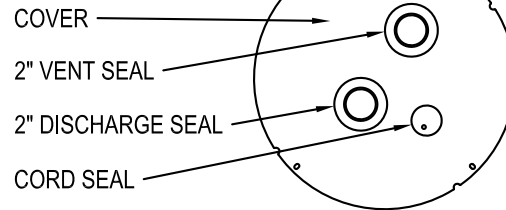

Installation

NOTE: This 20.5" diameter cover with 19.5" bolt circle fits most 18" sump and sewage basins. A 3" vent seal and 4" basin inlet seal are provided if needed.

1. Unplug your pump.
2. Remove pipe and cord seals from cover.
3. Apply seal tape to basin rim inside the bolt circle as shown.
4. Pull your pump's power cord through the cover's cord hole as shown.
5. Slide the cover over the pump's discharge pipe through the discharge opening as shown.
6. Bolt the cover down as shown with the discharge pipe positioned in the center of the discharge opening. Do not overtighten. Slide the discharge pipe seal over the discharge pipe and snap in place in the cover as shown.
7. Slide the vent pipe seal up over your vent pipe. Position the vent pipe in the center of the vent opening extending into the basin at least one inch. The vent pipe will need to be self-supporting in this position as the seal will not support the vent pipe. Snap the vent seal into the cover as shown.
8. Pull the pump's power cord through the cord opening, eliminating slack inside the basin. Insert the cord through the cord hole in the cord seal and press the cord seal into the cover as shown.
9. Install your check valve and the rest of your discharge plumbing to complete your installation.

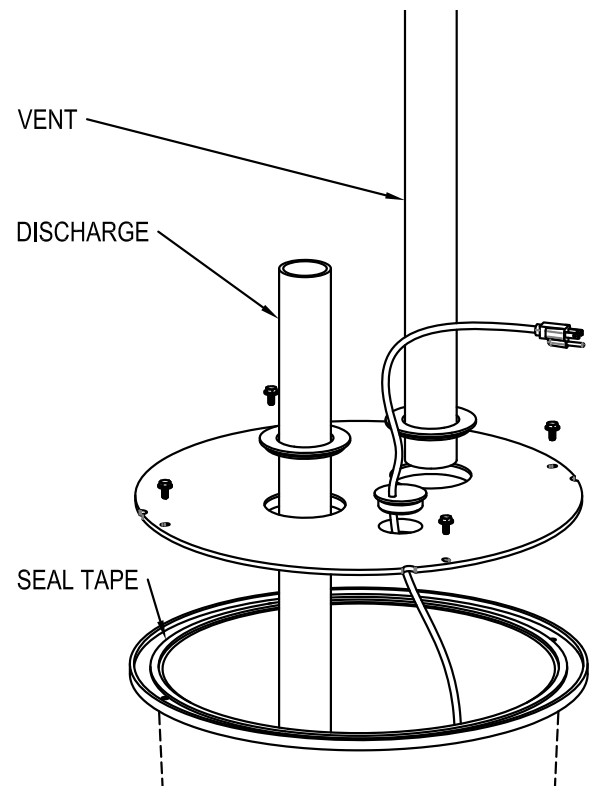

Safety Information



WARNING: Failure to install basin cover as shown will create a safety risk. Install cover as shown.

Warranty

This product is warranted to the original consumer purchaser to be free from defects in material and workmanship for a period of one year from the date of purchase. For additional details and questions, please contact Everbilt Customer Service at 1-877-297-6069.

EVERBILT

HOMEDEPOT.com

Please contact 1-877-297-6069 for further assistance.