

Assembly Instructions



Caution: You must read this before you proceed

Trolley





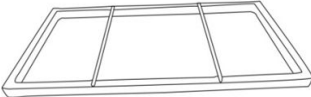

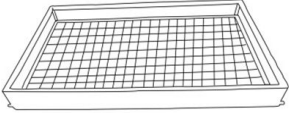
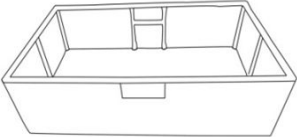
**CAUTION : This Trolley is NOT a TOY.
Keep your child / children at bay during the assembly process.**

Parts List

Label	Picture	Description	QTY
A		Top Shelf	1
B		Bottom Shelf	1
C		Side Panels with Handrail	2
D		Middle Tray	1
E		Drawer	1

Hardware

Label	Picture	Description	QTY
G		Wheel(with break)	2
H		Bolt(M6*50MM)	9
I		Allen Key	1
J		Wheel(with no break)	2

Assembly Preparation

Before Beginning Assembly:

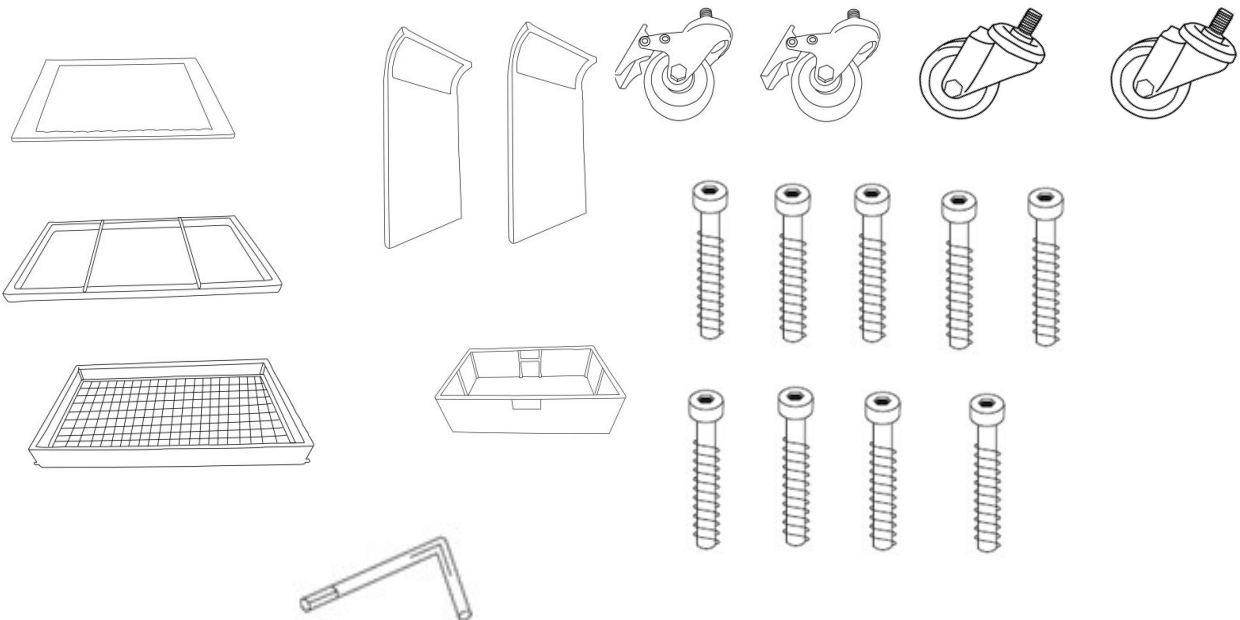

- Read instructions, cover to cover-



- Have 2 adults on hand for assembly-



- Do not assemble on flooring or carpet-



- Assemble on a clean non-marring surface (packing foam)-



- Save all packaging until finished-

Assembly Steps

Step 1

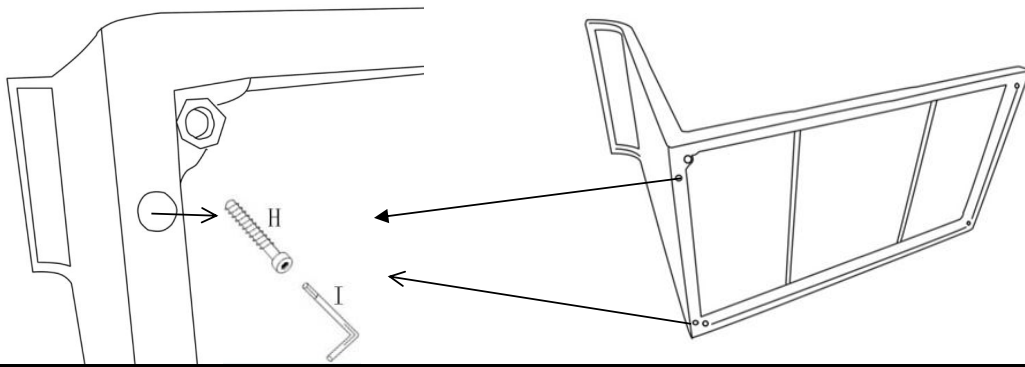

Open the carton and place all the parts onto a clean, non-marring surface. Attach Bottom Shelf(B) to Side Panel with Handrail(C) using Bolt(H) with Allen Key(I).

Do not over tighten Bolts.

Caution: The Trolley Parts are heavy, always have a second Adult to assist you whenever lifting or moving them.

Step 2

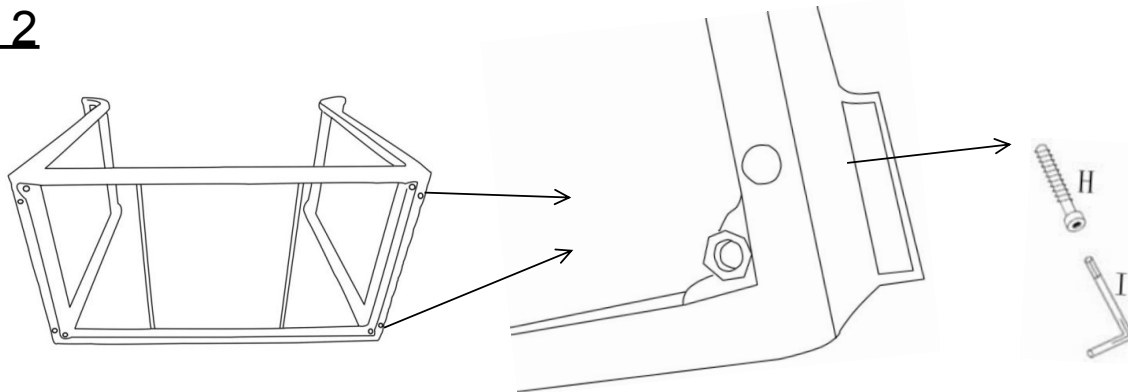

Attach the second Side Panel with Handrail(C) to Bottom Shelf(B) using Bolt(H) with Allen Key(I).

Do not over tighten Bolts.

Step 3

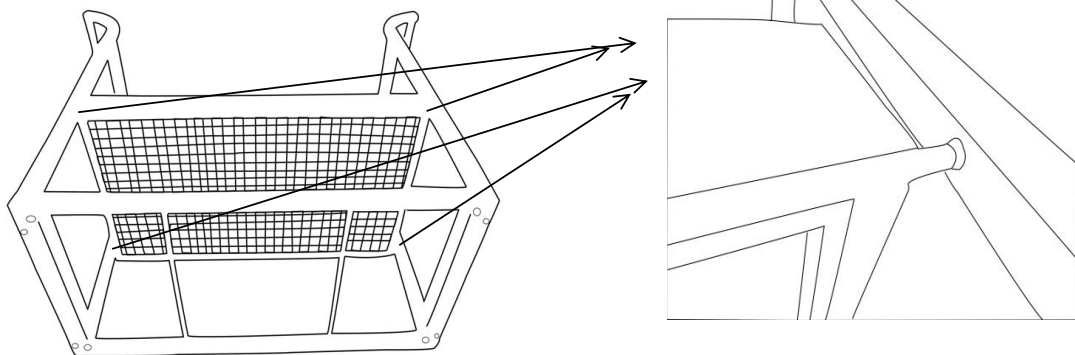

Place Middle Tray (D) between Side Panels with Handrail (C) by inserting the four pegs into the mounting points at the center of the Side Panels with Handrail (C).

Step 4

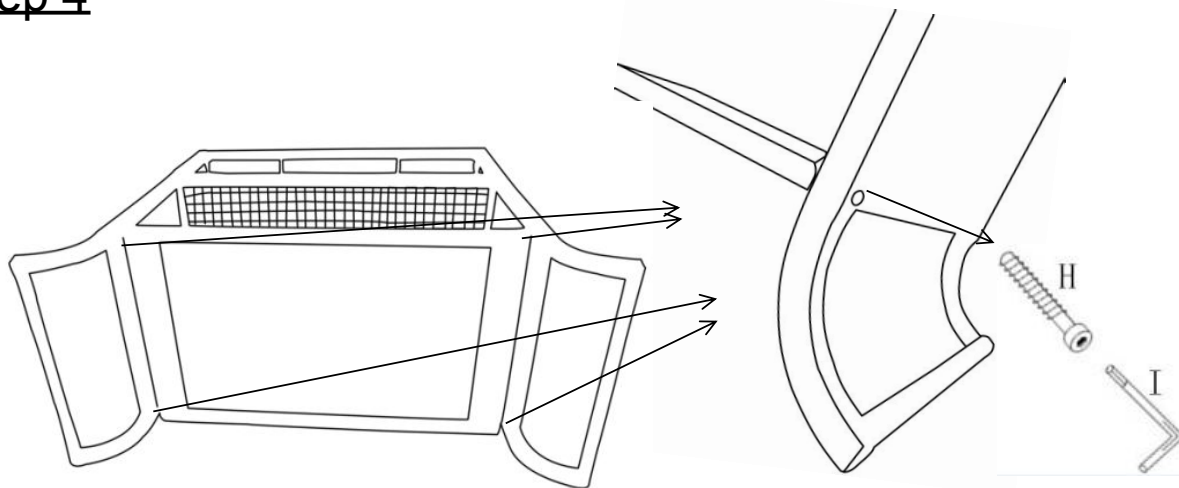

Attach Top Shelf(A) to both sides of the Side Panels with Handrail(C) using Bolt(H) with Allen Key(I).

Do NOT over tighten Bolts.

Stand Trolley up and test for levelness.

Now, in a sequential manner, tighten all Bolts at all joints.

NOTE : DO NOT fully tighten A BOLT in one go and then move on to the next. In a sequential manner and a gradual tightening method of a bolt, then move on to the next bolt, in a sequential manner. This latter methodology will ensure minimal unevenness once all bolts are fully tightened down.

Step 5

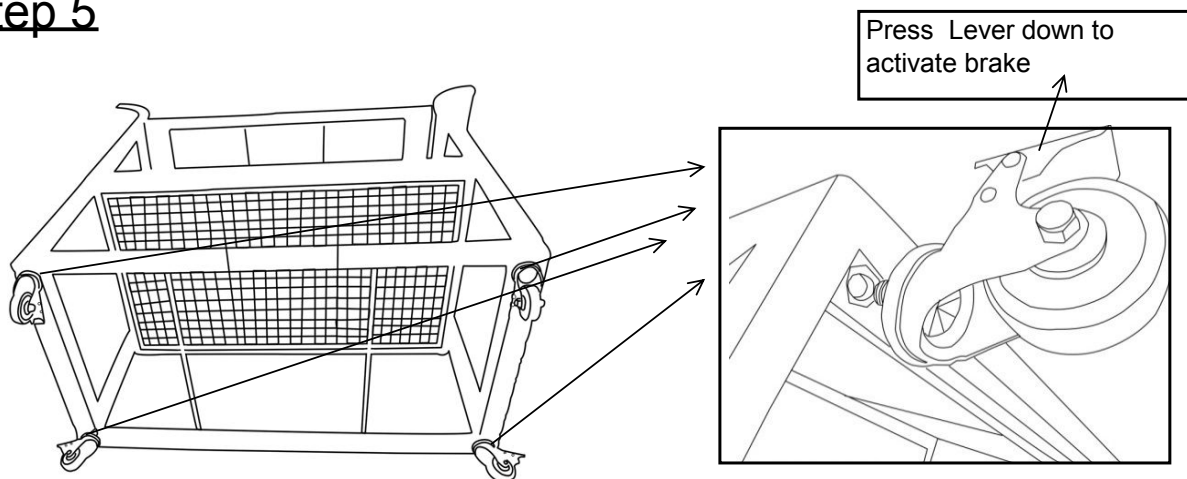

Turn-in Wheels(G&J) by hand, into the four Mounting Positions.

Note: There are two wheels have braking functions.,you must keep this two wheels installed in the same end. To activate the Brake press the Lever down. To release the Brake lift the Lever up.

Step 6



Place the Drawer(E) in the Bottom Shelf(B) by threading the slots located on the sides of each together.

Step 7



Your Trolley is ready for use.

Care & Maintenance

-  Do not put hot items directly on furniture surface.
 -  Do not clean furniture with harsh cleansers or polish.
 -  To obtain the longest lifespan of your outdoor products, minimizing exposure to direct sunlight is recommended.
 -  Children should not climb or jump on the furniture.
 -  Do not write on furniture without a padded barrier to protect the surface.
 -  To obtain the longest lifespan of your outdoor products, avoid extended and lengthy exposure to rain, snow, and direct sunshine. Whenever possible cover the product and /or place under patio or awnings.
 -  Not for commercial use. For residential use only .
 -  Stains may be removed with mild soap solution and damp cloth.
 -  Keep away from sources of ignition.
-
-  Dust and pick-up spills using a clean, non-colored, lint-free cloth .