

GREX®

P6 SERIES

23 Ga. Headless Pinners

P635

23 Ga. Headless Pinner
3/8" to 1-3/8" Length Fastener Range

P645

23 Ga. Headless Pinner
3/8" to 1-3/4" Length Fastener Range

P645L

23 Ga. Headless Pinner w/ Auto Lock-Out
1/2" to 1-3/4" Length Fastener Range

P650

23 Ga. Headless Pinner
3/8" to 2" Length Fastener Range

P650L

23 Ga. Headless Pinner w/ Auto Lock-Out
1/2" to 2" Length Fastener Range

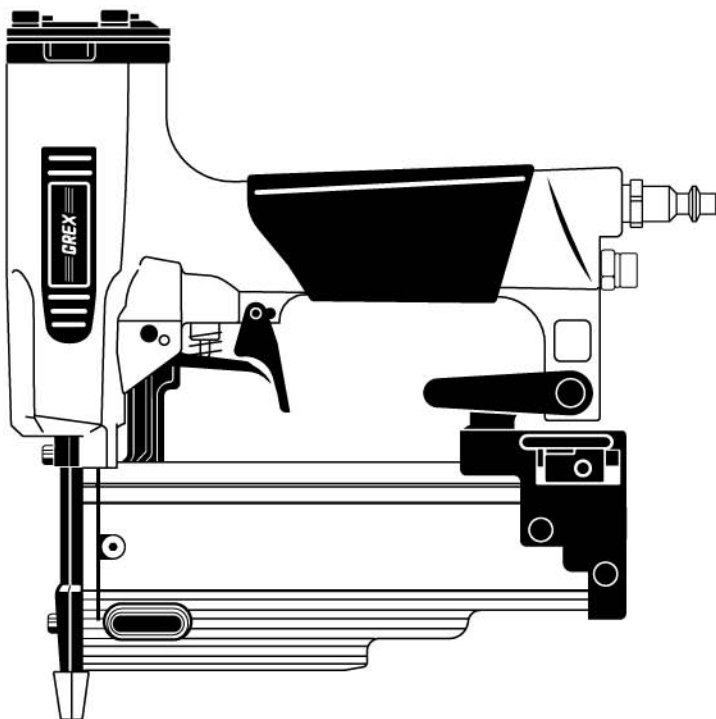

CAUTION: Before attempting to use or service this tool, carefully read and understand all rules and instructions for safe operation.



NOTE: This manual includes safety warnings, operation instructions, and tips on the maintenance and inspection of this tool.

Congratulations on your purchase of a **GreX 23 Gauge Headless Pinner**; a high performance precision tool that has become an industry standard in driving the smallest nails. Precision machining and carefully selected materials are employed in the manufacturing process of each tool to ensure consistent high performance and adherence to GreX's high quality standards. Because of the fine and narrow tip of the driver, to maintain your GreX 23 Gauge Headless Pinner at its peak performance, proper care and attention to its operation must be observed. Please take the time to read and understand this owner's manual so you can get the most out of your pinner and ensure long-lasting, reliable operation. **Thank you for choosing GreX.**

TABLE OF CONTENTS

| | |
|---------------------------------------|----|
| 1.0 Safety Instructions | 1 |
| 1.1 Registering Your Tool | 1 |
| 1.2 Employer's Responsibilities | 1 |
| 1.3 Safety Instructions | 2 |
| 2.0 Compressed Air System | 4 |
| 3.0 Tool Specifications | 5 |
| 3.1 Kit Contents | 5 |
| 3.2 Suggested Applications | 5 |
| 3.3 Technical Specifications | 5 |
| 3.4 Tool Anatomy | 6 |
| 4.0 Fastener Specifications | 7 |
| 4.1 Fastener Length Compatibility | 7 |
| 4.2 Fastener Product Numbers | 8 |
| 5.0 Tool Operation | 9 |
| 5.1 Pre-Operation Checklist | 9 |
| 5.2 Testing the Tool | 10 |
| 5.3 Adjusting Air Pressure | 12 |
| 5.4 Loading Fasteners | 13 |
| 5.5 Mode of Operation | 14 |
| 5.6 No-Mar Rubber Tip | 15 |
| 5.7 Auto Lock-out Feature | 16 |
| 6.0 Maintenance and Inspection | 17 |
| 6.1 Clearing Jammed Fasteners | 17 |
| 6.2 Clean and Inspect Daily | 18 |
| 6.3 Lubrication | 18 |
| 6.4 Storage | 18 |
| 6.5 Cold Weather Care | 19 |
| 6.6 Troubleshooting | 20 |

1.1 REGISTERING YOUR TOOL

IMPORTANT: Please fill out and return the enclosed Product Registration Card or register online at www.grexusa.com within the next ten days. By registering your tool, we will be able to acknowledge the limited warranty offered for your GreX product.

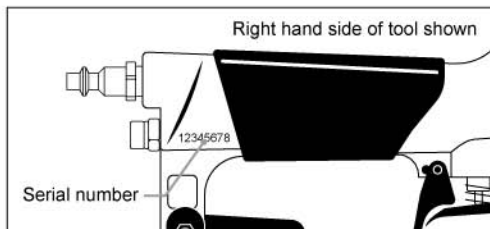

1.2 EMPLOYER'S RESPONSIBILITIES

1. Keep this manual available for use by all people assigned to use this tool.
2. Employer must enforce compliance with safety warnings & all instructions contained in this manual.
3. For personal safety & proper operation of this tool, read and follow all of these instructions carefully.
4. Ensure that tools are used only when operators & others in work area are wearing safety protection.
5. Enforce the use of safety protection, especially safety eyewear, by operators and others in area.
6. Keep tools in safe working order and maintain them properly.
7. Ensure that tools that require repair are not further used before repair.

1.3 SAFETY INSTRUCTIONS



WARNING: Do not attempt to operate this tool unless you have read and fully understood all instructions and safety precautions contained in this manual. Failure to comply can result in serious injury to yourself and bystanders.

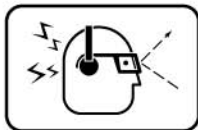

1. Always wear protective equipment.

To prevent eye injuries, safety glasses should be worn by the operator and others in the work area that conforms to requirements of ANSI Z87.1 & provides both frontal & side protection. Always wear other personal protective equipment such as hearing protection & hard hats.



2. Use only clean, dry, regulated compressed air.

Do not operate the tool on oxygen, carbon dioxide, combustible gases or any other bottled gases; the tool will explode and cause serious injury.



3. Operate within the proper air pressure range.

Do not exceed the maximum recommended air pressure of 120 psi (8.3 bar) and never connect the tool to air pressure which potentially exceeds 200 psi (13.7 bar) as the tool can burst.

4. Use the correct type of air hose.

Air hose must have a minimum working pressure rating of 150 psi (10.4 bar) or 150% of the maximum pressure produced in the system, whichever is higher.

5. Do not operate tool near flammable substances.

Volatile fumes from these substances can be drawn into the compressor and compressed together with the air, causing risk of explosion.

6. Never point tool toward yourself or anyone else.

Always assume tool contains fasteners. Keep tool pointed away from yourself and others at all times. Never engage in horseplay with your tool. Respect your tool as a working implement.

7. Keep visitors away.

Do not let visitors handle the tool. All visitors should be kept safely away from the work area.

8. Inspect tool condition and maintain with care.

Make sure screws and caps are securely tightened at all times. Never use tool if parts are missing or damaged, leaks air, or needs repair. Keep tool clean and lubricated for better and safer performance.

9. Drive fasteners carefully.

Never drive fasteners into materials too hard to penetrate. Do not drive fasteners into thin boards or near corners and edges of work piece; they may be driven through or away from work piece. Do not drive fasteners on top of other fasteners or with tool at too steep an angle; the fastener can ricochet and cause personal injury or injury to bystanders.

1.3 SAFETY INSTRUCTIONS (continued)

10. Load fasteners carefully.

Always disconnect air supply from tool before loading fasteners. Have tool pointed downwards and away from yourself or any bystanders at all times.

11. Use only relieving couplers on tool and air supply hose.

The tool and air supply hose must have a hose coupling such that all pressure is removed from the tool when the coupling is disconnected. If not, the tool can remain charged with air after disconnecting and be able to drive a fastener even after being disconnected.

12. Only connect air hose when actively operating tool.

Disconnect tool from air before performing any tool maintenance, clearing jammed fasteners, leaving work area, moving tool to another location, or handing the tool to another person.

13. Empty fasteners from magazine when tool is not in use.

Remove all fasteners from tool before connecting air hose, doing tool maintenance, or when operation has been completed or suspended.

14. Dress properly.

Be sure not to wear clothing or jewelry that may be caught in moving parts. Rubber gloves and non-slip footwear are recommended when working outdoors. Wear protective hair covering to contain long hair.

15. Handle tool carefully and correctly.

Operate tool according to this manual. Never allow the tool to be operated by children, individuals unfamiliar with its operation or unauthorized personnel. Do not drop the tool or strike the tool against hard surfaces; and do not scratch or engrave signs on the tool. Doing so may result in cracks on the tool surface, which can be extremely dangerous because of the high pressures.

16. Keep work area clean.

Cluttered areas invite injuries. Clear work areas free of unnecessary tools, debris, furniture, etc.

17. Stay alert.

Watch what you are doing. Use common sense. Do not operate tool when tired, or under the influence of alcohol, drugs, or medication that causes drowsiness.

18. Do not overreach.

Keep proper footing and balance at all times.

19. Keep idle tool in storage.

When not in use, tool should be kept in dry, and high or locked-up places - out of reach of children.

20. Never use tool for application other than those specified in this manual.

Using tool for applications other than those intended for may harm the tool, cause personal injury to operator and injury to bystanders.

21. Use only parts, accessories or fasteners supplied or recommended by GREX.

Unauthorized parts, accessories, or fasteners may void your warranty and can lead to malfunction and resulting injuries. Do not modify the tool without written approval from GREX.

2.0 COMPRESSED AIR SYSTEM



NOTE: The following illustration shows the ideal mode of connection to the compressed air system which will increase the efficiency and useful life of the tool.

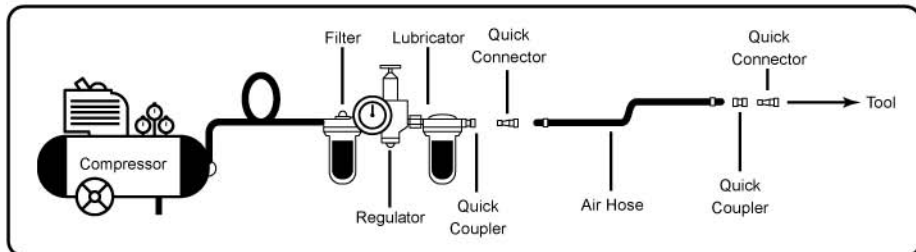

1. Power Source

- Use clean, dry, regulated compressed air as a power source for the tool.
- Air compressors used to supply air to this tool must comply with the requirements of the latest version of ANSI Standard B 19.3 "Safety Standard For Compressors For Process Industries".
- Moisture or oil in the air compressor may accelerate wear and corrosion in the tool.
- Never use oxygen, combustible gases or any other bottled gases.

2. Filter-Regulator-Lubricator

- Use a regulator with a pressure range of 0-120 psi (0-8.3 bar).
- Filter-regulator-lubricator units supply an optimum condition for the tool and extend tool life.
- These units should always be used:
 - » Filter The filter removes moisture and dirt mixed in the compressed air. Drain daily unless fitted with an automatic drain. Keep the filter clean by regular maintenance.
 - » Regulator The regulator controls the operating pressure for safe operation of the tool. Inspect the regulator before operation to be sure it operates properly.
 - » Lubricator The lubricator supplies an oil mist to the tool. Inspect the lubricator before operation to be sure the supply of lubricant is adequate.



NOTE: If manual lubrication is used, then a lubricator is not necessary. See "Lubrication" under the "Maintenance and Inspection" Section on page 18.

3. Air Hose

Air hose must have a minimum working pressure rating of 150 psi (10.4 bar, 10.6 kgf/cm²) or 150% of the maximum pressure produced in the system, whichever is higher.

4. Hose Coupling

Install a 1/4" NPT male plug at the air inlet of the tool. A female coupler must be installed on the air hose. The hose coupling (male-female coupler) must remove all pressure from the tool when disconnected. Never use a non-relieving coupler on the tool. Doing so will leave the tool charged with air after disconnecting and be able to drive a fastener even after being disconnected.

3.1 KIT CONTENTS

- **GreX 23 Ga. Headless Pinner**
- **Tool Carrying Case**
- **Owner's Manual**
with Parts diagram and Product Warranty Card
- **Safety Goggle**
Not included with P635
- **Bottle of Tool Oil**
After first use, to avoid oil from leaking, store the bottle up right in a safe place.
- **Hex Keys**
2.0mm, 2.5mm, & 4.0mm Hex Keys
3.0mm Hex Key (stored on tool)



3.2 SUGGESTED APPLICATIONS

Crown molding, Light wood assembly, Finish and trim work, Molding and decorative trim, Dowel and joint pinning, Mirror and picture frame assembly, Paneling, External softwood trim, Rattan furniture, Glazing strips, Craft work, Window beading, Display and sign work.

3.3 TECHNICAL SPECIFICATIONS

| | P635 | P645 | P645L | P650 | P650L |
|---------------------------|----------------------------|--------------------|--------------------|--------------------|--------------------|
| Tool Length | 7.75" 20cm | 7.75" 20cm | 7.75" 20cm | 7.75" 20cm | 7.75" 20cm |
| Tool Height | 7.5" 19cm | 8.75" 22cm | 8.75" 22cm | 8.75" 22cm | 8.75" 22cm |
| Tool Width | 1.5" 3.8cm | 1.5" 3.8cm | 1.5" 3.8cm | 1.5" 3.8cm | 1.5" 3.8cm |
| Min. Operating Pressure * | 60 psi 4.2 bar | 60 psi 4.2 bar | 60 psi 4.2 bar | 60 psi 4.2 bar | 60 psi 4.2 bar |
| Max. Operating Pressure * | 100 psi 6.9 bar | 110 psi 7.6 bar | 110 psi 7.6 bar | 110 psi 7.6 bar | 110 psi 7.6 bar |
| Fastener Capacity | 1 strip (approx. 100 pins) | | | | |
| Air Inlet | 1/4" (6mm) NPT male plug | | | | |

* Refer to section titled "Adjusting Air Pressure" on page 12 for optimal operating air pressure settings.

3.4 TOOL ANATOMY

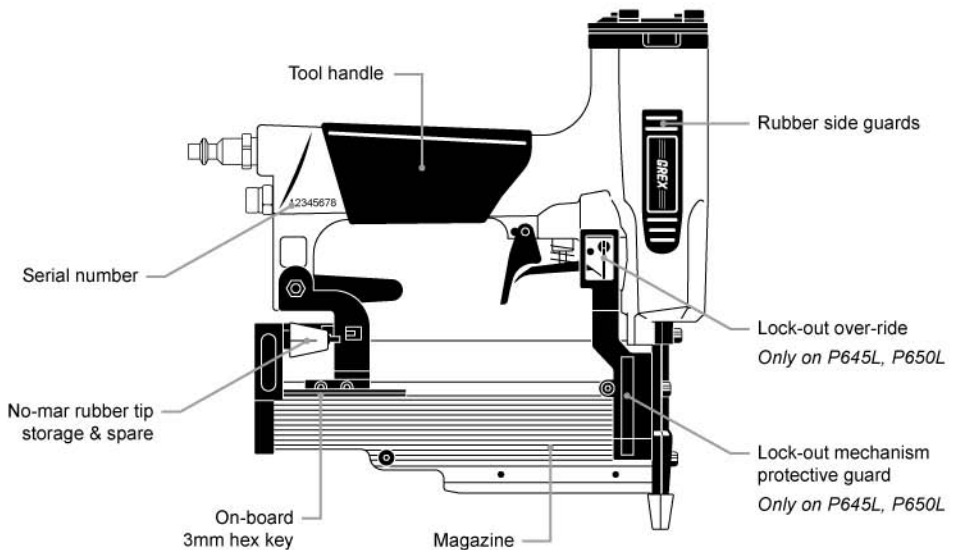
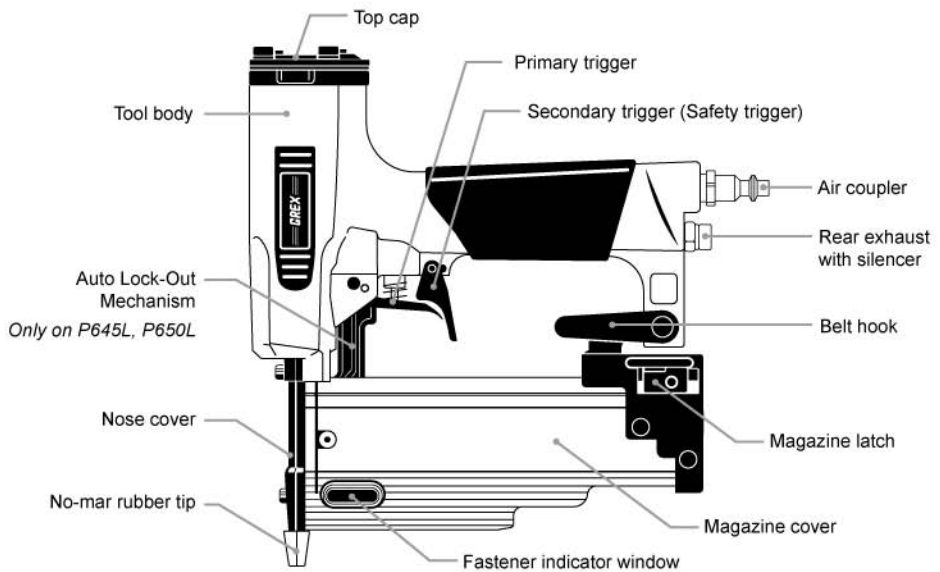

4.1 FASTENER LENGTH COMPATIBILITY



WARNING

ONLY use fasteners designated as **23 GAUGE HEADLESS PINS**.

Do not use 23 gauge pins that have a brad or slight headed brad, doing so may cause jamming and damage to your tool.

DO NOT use 1-1/4" (32mm) length pins. Doing so may result in jamming, because the magazine is not designed to accommodate this pin length.

DO NOT use 3/8" (10mm) length pins with a **P645L** or **P650L**. Because these two models have the auto lock-out feature, using 3/8" (10mm) length pins will keep the trigger in the locked position.

Follow the chart below to determine which pin lengths can be used with your GreX 23 Gauge Headless Pinner model. Using pin lengths not intended for your particular tool may result in jamming and damage to your tool.

| Fastener Lengths | | P635 | P645 | P645L | P650 | P650L |
|------------------|------|--|------------------------------|------------------------------|------------------------------|------------------------------|
| 3/8" | 10mm | • | • | | • | |
| 1/2" | 12mm | • | • | • | • | • |
| 5/8" | 15mm | • | • | • | • | • |
| 3/4" | 20mm | • | • | • | • | • |
| 7/8" | 22mm | • | • | • | • | • |
| 1" | 25mm | • | • | • | • | • |
| 1-1/8" | 28mm | • | • | • | • | • |
| 1-3/16" | 30mm | • | • | • | • | • |
| 1-1/4" | 32mm | Do not use 1-1/4" (32mm) pins for any of these tools. | | | | |
| 1-3/8" | 35mm | • | • | • | • | • |
| 1-1/2" | 38mm | | • | • | • | • |
| 1-9/16" | 40mm | | • | • | • | • |
| 1-3/4" | 45mm | | • | • | • | • |
| 2" | 50mm | | | | • | • |
| | | 9 Total Length | 12 Total Length | 11 Total Length | 13 Total Length | 12 Total Length |

4.2 FASTENER PRODUCT NUMBERS



WARNING

Although any brand of **23 GAUGE HEADLESS PINS** are compatible with your GreX Pinner, GreX pins are highly recommended due to the optimal tensile strength of the steel used. Using poor quality pins will cause jamming and damage to your tool.









Use the following chart to identify the product number for the types and different lengths of 23 Gauge Headless Pins available from GreX.

| Fastener Lengths | | Galvanized & Coated 10,000 pcs. per box | Galvanized & Coated 2,500 pcs. per pack | Stainless Steel 5,000 pcs. per box |
|--|------|--|--|---------------------------------------|
| 3/8" | 10mm | P6/10L | P6/10-2.5 | P6/10-ST |
| 1/2" | 12mm | P6/12L | P6/12-2.5 | P6/12-ST |
| 5/8" | 15mm | P6/15L | P6/15-2.5 | P6/15-ST |
| 3/4" | 20mm | P6/20L | P6/20-2.5 | P6/20-ST |
| 7/8" | 22mm | P6/22L | P6/22-2.5 | |
| 1" | 25mm | P6/25L | P6/25-2.5 | P6/25-ST |
| 1-1/8" | 28mm | P6/28L | P6/28-2.5 | |
| 1-3/16" | 30mm | P6/30L | P6/30-2.5 | P6/30-ST |
| 1-3/8" | 35mm | P6/35L | P6/35-2.5 | P6/35-ST |
| 1-1/2" | 38mm | P6/38L | P6/38-2.5 | P6/38-ST |
| 1-9/16" | 40mm | P6/40L | P6/40-2.5 | |
| 1-3/4" | 45mm | P6/45L | P6/45-2.5 | P6/45-ST |
| 2" | 50mm | P6/50L | P6/50-2.5 | P6/50-ST |
| <p>P6/MP-3 Multi-Pack Pins 3/8" (10mm), 1/2" (12mm), 5/8" (20mm), 3/4" (20mm), 1" (25mm), 1-3/8" (35mm) 3,000 pcs. total per pack, 500 pcs. of each length</p> | | | | |

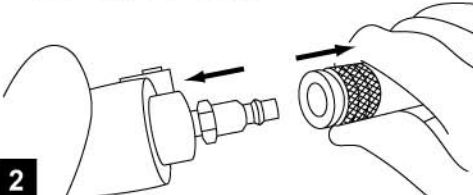
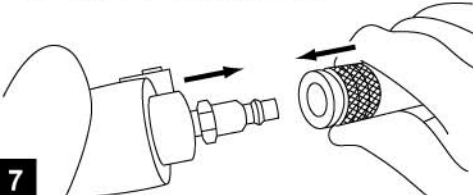
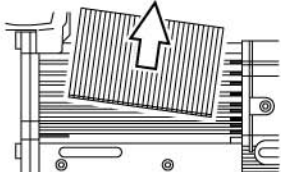
5.1 PRE-OPERATION CHECKLIST

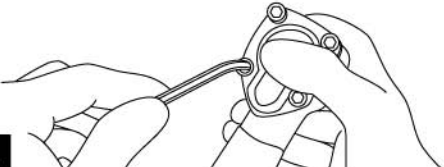

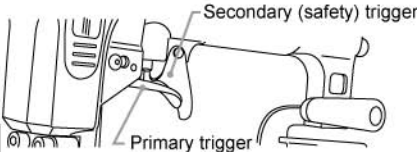
WARNING: Read section titled "Safety Instructions" on pages 2 and 3 before operating tool.

| | |
|--|--|
| <p>1</p> <p>Wear safety glasses or goggles.</p>  | <p>6</p> <p>Adjust the air supply to 70 psi.</p>  |
| <p>2</p> <p>Disconnect the air supply.</p>  | <p>7</p> <p>Connect the air supply to the tool.</p>  |
| <p>3</p> <p>Remove all fasteners from tool.</p>  | <p>8</p> <p>Check for any air leakage. The tool must not leak air to operate properly.</p>  |
| <p>4</p> <p>Inspect all screw tightness.</p>  | <p>9</p> <p>Follow steps in the section "Testing the Tool".</p>  |
| <p>5</p> <p>Check for the smooth and proper operation of primary and secondary triggers.</p>  | <p>10</p> <p>Adjust operating air pressure by following steps in section "Adjusting Air Pressure".</p>  |

5.2 TESTING THE TOOL



WARNING

Read section titled "Safety Instructions" on pages 2 and 3 before operating tool.

Never use tool unless safety is operating properly.

If abnormal operation occurs, contact GreX or an authorized service center immediately.

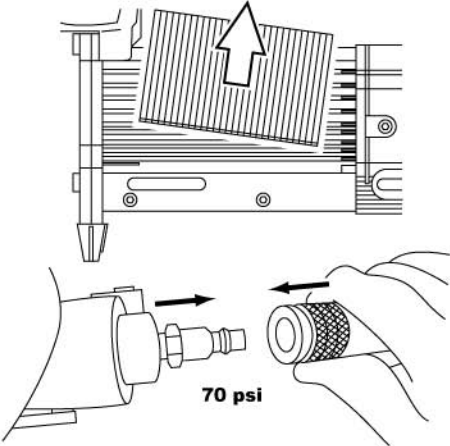
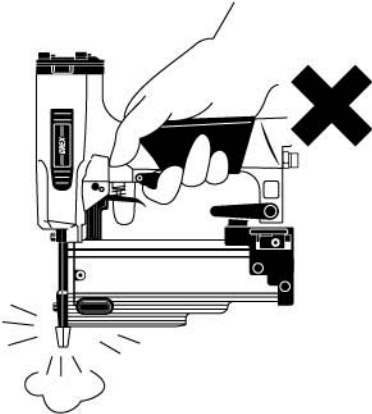
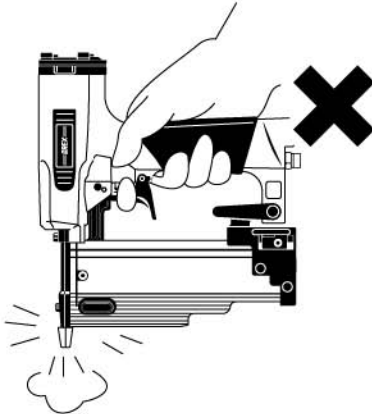
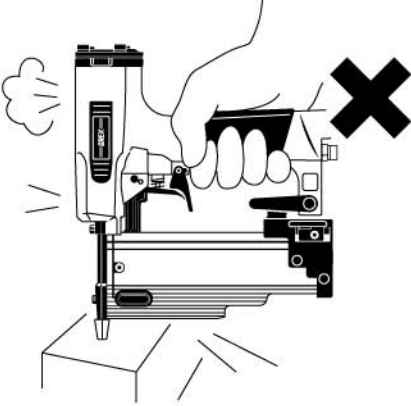
| | |
|--|--|
| <p>1 With fasteners removed, set air supply to 70 psi and connect air hose.</p>  | <p>3 Release primary trigger. Pull secondary trigger ONLY. The tool must NOT drive.</p>  |
| <p>2 Hold tool pointed downward. Pull primary trigger ONLY. The tool must NOT drive.</p>  | <p>4 With fingers OFF BOTH triggers. Place tool nose against work piece. The tool must NOT drive.</p>  |

Instructions continued on following page.

5.2 TESTING THE TOOL (continued)



WARNING

Read section titled "Safety Instructions" on pages 2 and 3 before operating tool.

Never use tool unless safety is operating properly.

If abnormal operation occurs, contact GreX or an authorized service center immediately.

5 For models: P635, P645, P650

With fingers **OFF BOTH** triggers,
Place tool nose against work piece.
Then pull secondary (safety) trigger,
Followed by primary trigger.

The tool **MUST** drive.

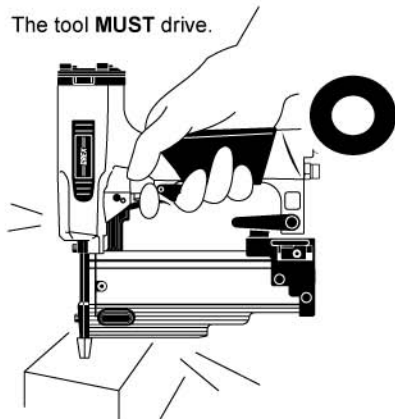

5 For models: P645L, P650L

With fingers **OFF BOTH** triggers,
Place tool nose against work piece.
Then pull secondary (safety) trigger,
Followed by primary trigger.

The tool must **NOT** drive.



Then release **BOTH** triggers.
Depress and hold the Lock-out over-ride.
Pull secondary (safety) trigger,
Followed by primary trigger.

The tool must **MUST** drive.



Lock-out
over-ride

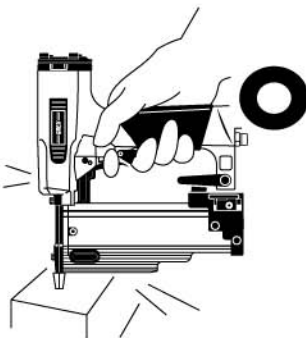

If no abnormal operation is observed, you may load fasteners into the tool.

5.3 ADJUSTING AIR PRESSURE



WARNING

Read section titled "Safety Instructions" on pages 2 and 3 before operating tool.

Insufficient operating air pressures will damage your tool. Your GreX Pinner is a precision tool capable of driving very fine 23 gauge pins. Optimal operating air pressures are required to minimize wear and prevent damage.

- Before driving fasteners into the work piece, test drive fasteners on similar materials to be used in the actual application to determine the optimal air pressure.
- Insufficient operating air pressures will prevent your tool from setting pins all the way into your work piece and also cause the driver to drive pins in at insufficient speeds. This forces the driver to "push" rather than quickly "punch" pins into the work piece resulting in excessive stress on the driver tip, which will lead to increased wear and damage.
- Excessive operating air pressures may set pins too deep into your work piece, damage the work piece, over stress the tool and increase driver wear.

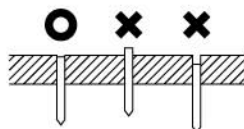

- Use the guide below to adjust the operating air pressure for the particular GreX Pinner that you own.

| | |
|--|---|
| <p>P635</p> | <ul style="list-style-type: none"> • Begin with the recommended operating air pressure of 100 psi. • For hard woods, maintain the operating air pressure at 100 psi. • For soft woods, the air pressure can be adjusted lower to prevent setting pins too deep. |
| <p>P645 P645L P650 P650L</p> | <ul style="list-style-type: none"> • Begin with the recommended operating air pressure of 110 psi. • For pins longer than 1-3/8", maintain the operating air pressure at 110 psi. • For pins shorter than 1-3/8", adjust operating air pressure to 100 psi <ul style="list-style-type: none"> - In hard woods, maintain the operating air pressure at 100 psi. - In soft woods, the air pressure can be lowered to prevent setting pins too deep. |



WARNING

When setting the operating air pressure for your tool, make sure your air compressor is capable of maintaining the recommended air pressures outlined above. Even if you regulate the air to a certain pressure, the actual line pressure may be lower due to the lower kick-in pressure set on your compressor. To constantly maintain sufficient air pressure for your tool, it may be necessary to adjust your compressor's kick-in pressure. Refer to your compressor's owner's manual for more information on your compressor's settings.

5.4 LOADING FASTENERS



WARNING

Read section titled "Safety Instructions" on pages 2 and 3 before operating tool.

NEVER load different lengths and/or types of fasteners at the same time. Doing so, could result in jamming and/or damage to your tool.

Before loading fasteners, **ALWAYS** remove existing fasteners and/or fastener strip fragments in the nose area that may have been left over from the previous work session.

Your GreX 23 Ga. Headless Pinner is designed with the patented "adjust-free magazine". Adjustments are unnecessary when using different fastener lengths. Follow the fastener loading instructions below carefully. Improper loading may cause jamming and/or damage to your tool.

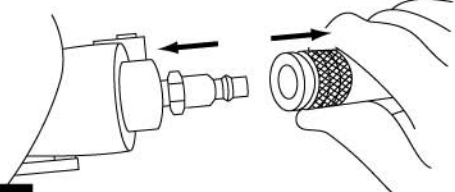
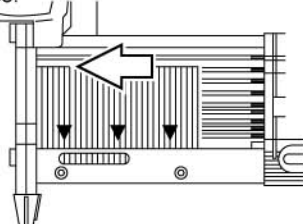
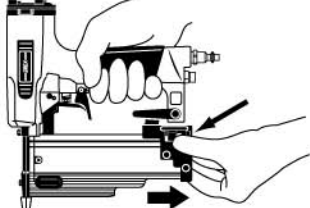
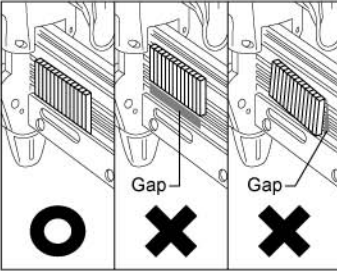
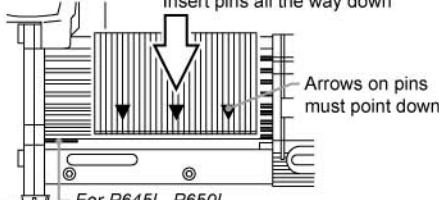
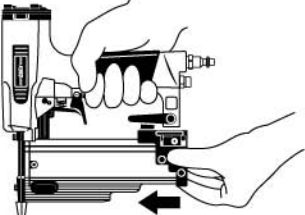
| | |
|--|---|
| <p>Disconnect your tool from the air supply.</p>  <p>1</p> | <p>Slide fasteners forward all the way into the tool nose.</p>  <p>4</p> |
| <p>Push down on magazine latch and gently pull magazine cover back as far as possible.</p>  <p>2</p> |  <p>5</p> |
| <p>Insert a strip of fasteners into the magazine. Insert pins all the way down</p>  <p>Arrows on pins must point down</p> <p>For P645L, P650L Insert fasteners behind this lock-out</p> <p>3</p> | <p>Push magazine cover forward until the magazine latch catches securely.</p>  <p>6</p> |



WARNING

When loading fasteners into the tool, do not depress the primary or secondary trigger. Keep yourself as well as other persons away from the nose to avoid possible injury.

5.5 MODE OF OPERATION



WARNING

Read section titled "Safety Instructions" on pages 2 and 3 before operating tool.

Before operating tool, make sure you have gone through the pre-operation checklist with no problems, adjusted the operating pressure correctly and loaded the fasteners correctly.



WARNING

The double trigger design is meant to prevent accidentally firing the tool. This tool does not have a contact safety at the nose. Once the secondary (safety) trigger is pulled, the primary trigger is active and will drive a pin if pulled. Operate your tool with extreme caution.

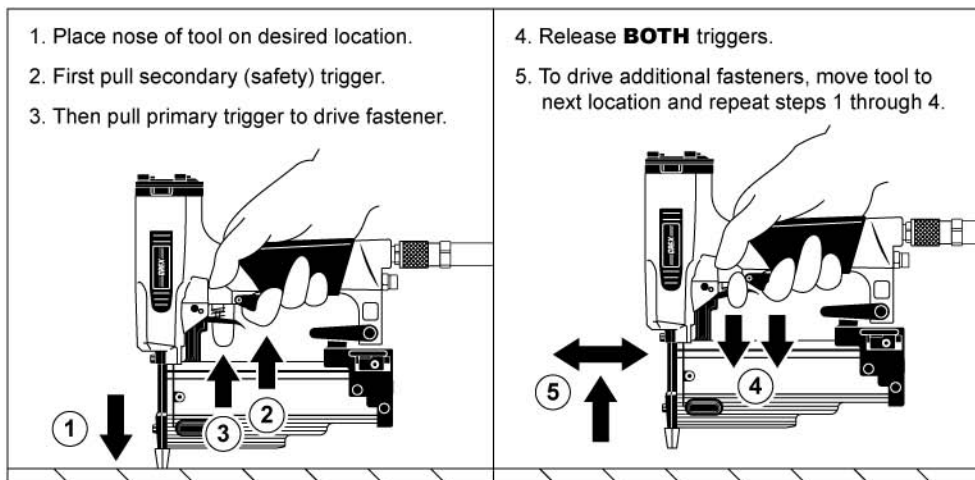

1. Place nose of tool on desired location.
2. First pull secondary (safety) trigger.
3. Then pull primary trigger to drive fastener.

4. Release **BOTH** triggers.
5. To drive additional fasteners, move tool to next location and repeat steps 1 through 4.



WARNING

DO NOT drive pins into metal. Doing so will damage the driver and may cause personal injury to yourself and/or bystanders. Make sure there is no hidden metal in the workpiece (such as screws and nails) that your pinner can potentially drive pins into.

DO NOT move or drag the nose of your tool across the workpiece surface when both triggers are pulled. Doing so may damage and possibly break the tip of your driver.

5.6 NO-MAR RUBBER TIP

The removable rubber tip prevents marring of your work material. It can also be easily removed and stored for safe-keeping behind the magazine cover end cap. Markings on the side of the tip creates a 4-point alignment guide to precisely place fasteners.

Attaching the Rubber Tip - Firmly push tip onto nose of the tool as shown in **Fig. A**. To ensure the tip locks securely onto the nose, face the side with the letter "P" towards the front.

No-Mar Tip Storage - When no-mar rubber tip is not necessary, it can be easily removed and stored for safe-keeping behind the magazine cover end cap. **Fig. B**

4-Point Alignment Guide - Markings on the side of the tip creates a 4-point alignment guide to precisely place fasteners. As shown in **Fig. C**, the markings on each side of the tip indicates the precise location where fastener will be driven. Simply align the four marks as a target shown in the figure.

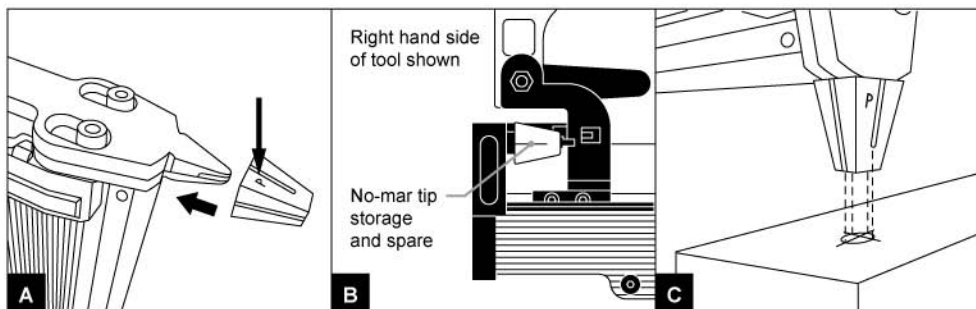

5.7 AUTO LOCK-OUT FEATURE (For P645L and P650L ONLY)

When tool magazine has approximately 6 ~ 7 fasteners remaining, the auto lock-out mechanism will activate and lock the primary trigger to prevent dry firing. Tool will **NOT** operate unless either more fasteners are loaded or the lock-out is over-ridden by following the steps below.

Auto Lock-out Over-ride



Over-riding the lock-out mechanism is not recommended unless for maintenance and tool inspection purposes only.

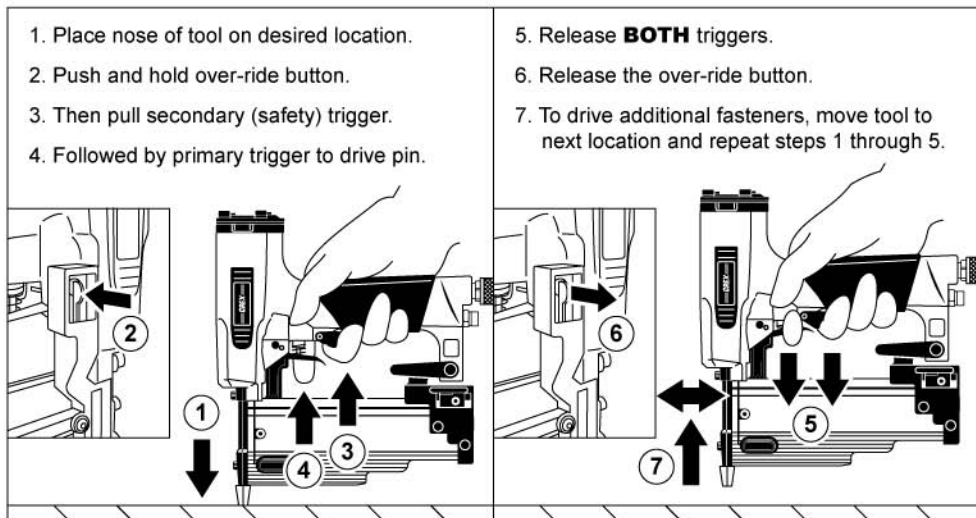

Removing Locked-Out Fasteners



WARNING

Before loading fasteners, **ALWAYS** remove existing fasteners and/or fastener strip fragments in the nose area that may have been left over from the previous work session. Loading fasteners of different lengths may cause jamming and/or damage to the driver.

Activated lock-out mechanism will leave remaining fasteners in the nose hidden from the operator's view. These fasteners can be accessed by:

1. Removing the nose cover plate by following the steps in the "Clearing Jammed Fasteners" section.
2. And/or using the lock-out over-ride method:
 - Disconnect tool from air supply.
 - Push and hold down lock-out over-ride button.
 - Tilt tool back to allow remaining fasteners to fall back from the nose. Be sure to remove all fasteners.
 - If fasteners still remain in nose, follow Step 1.



WARNING: Do not attempt to use a screw driver or any other object to remove fasteners from behind the lock-out plate. Doing so may damage the lock-out system.

6.1 CLEARING JAMMED FASTENERS

Disconnect air hose from tool and remove any remaining fasteners in magazine. Remove no-mar rubber tip.

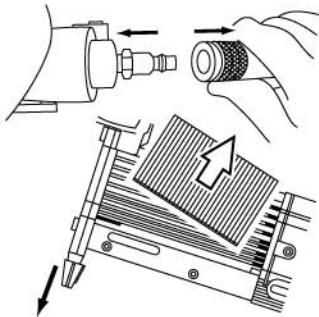

1

Remove the jammed fastener. It may be necessary to use a needle nose plier.

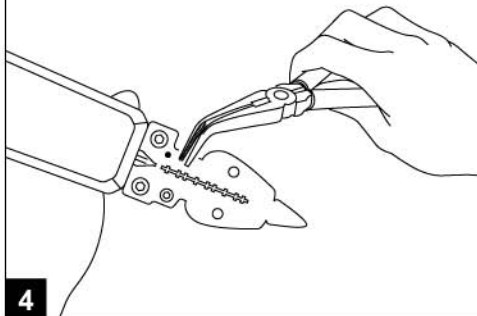

4

Loosen front nose plate screws using 3mm hex key stored on tool. Then slide down and lift off the front plate.

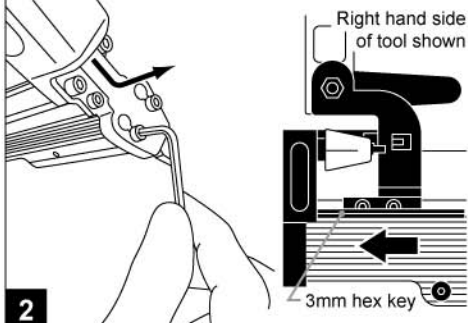

2

Align nose plate with screws, plate guide and driver blade. Then slide completely up.

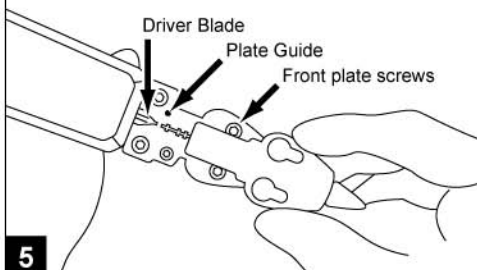

5

If the driver blade is in the down position, gently and carefully push it back into the tool. A flat-head screwdriver or something with a flat surface may be necessary.

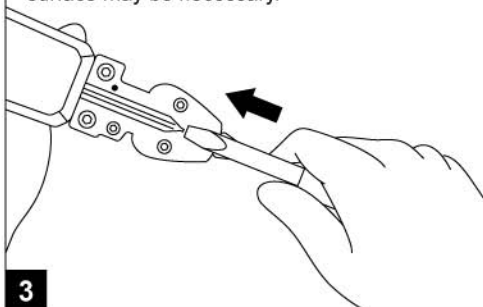

3

Tighten the front nose plate screws securely.

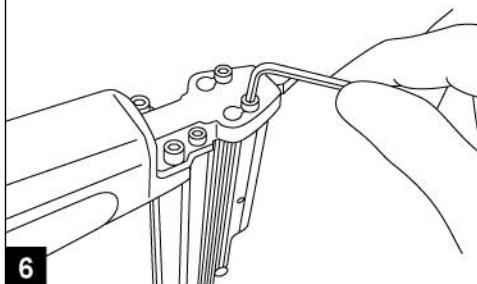

6



WARNING: Read section titled "Safety Instructions" on pages 2 and 3 before performing maintenance and inspection on tool.

6.2 CLEAN AND INSPECT DAILY

DANGER: Never use gasoline or other flammable liquids to clean the tool. Vapors in the tool will ignite by a spark and cause the tool to explode and result in death or serious injury.

Wipe tool clean

Use non-flammable cleaning solutions to wipe exterior of tool only if necessary. **DO NOT SOAK** tool with cleaning solutions, such solutions can damage internal parts.

Remove tar buildup

Use kerosene #2 fuel oil or diesel fuel. Do not allow solvent to get into cylinder or damage may occur.

CAUTION: Dry off tool completely before use.

Clean the magazine

Remove wooden chips which may have accumulated in the magazine. Lubricate with tool lubricant.

CAUTION: Check that the magazine cover slides smoothly by pulling it with a finger. If not smooth, fasteners can be driven at an irregular angle and injure someone.

Maintain compressed air system

Drain air line filter daily to prevent accumulation of moisture and dirt by opening the manual petcock on your compressor. Keep lubricator filled to maintain proper lubrication to tool. Clean air filter element to prevent clogging of filter with dirt. Also drain the air compressor when not in use. **ALWAYS** follow your compressor's owner's manual for safe and proper operation.

6.3 LUBRICATION

1. Tool requires lubrication before first time use and occasionally depending on frequency of usage.
2. First disconnect the air supply from the tool before lubricating.
3. Put in a drop of spindle oil UNOCAL RX22, or 3-in-1 oil into air inlet. Never use detergent oil or additives. Operate tool briefly after adding oil.
4. Wipe off excess oil at exhaust. Do not over lubricate, excessive oil will damage o-rings, and can mix with spent air which may stain the work surface. Blank fire the nailer (without fasteners) to purge excess oil before beginning work.

If in-line oiler is used (refer to section titled "Compressed Air System" for more information), manual lubrication through the air inlet is not required on a daily basis.

6.4 STORAGE

- When not in use for an extended period, apply a thin coat of lubricant to the steel parts to avoid rust.
- Do not store tool in a cold weather environment. Keep tool in a warm area.
- When not in use, the tool should be stored in a warm and dry area - out of reach of children.



WARNING: Read section titled "Safety Instructions" on pages 2 and 3 before performing maintenance and inspection on tool.

6.5 COLD WEATHER CARE

Do not store tool in a cold weather environment. Keep your tool in a warm area until the beginning of work. If the tool is already cold, bring it to a warm area and use the following procedures to warm up the components:

1. Reduce regulated pressure to 30 psi.
2. Remove **ALL** fasteners from tool.
3. Connect air hose & blank fire the tool. Slow speed operation tends to warm up moving parts.
4. Once tool is warmed up, re-adjust regulator to working pressure and reload tool.

6.6 TROUBLESHOOTING



WARNING

Read section titled "Safety Instructions" before attempting to troubleshoot tool. Stop using the tool immediately if any of the following problems occur. Serious personal injury could occur. Most minor problems can be resolved quickly and easily by the table below. If problems persist, contact Grex or an authorized service center only.

Disconnect tool from air supply before performing any service procedures.

| Symptom | Possible Cause | Remedy |
|---|--|--|
| Fasteners will not drive deep enough. | Driver blade rounded off and slipping off fastener head or broken. | Replace driver blade. |
| | Air pressure too low. | Increase to adequate air pressure. |
| Fasteners driven too deeply. | Worn bumper and/or piston spacer. | Replace bumper or piston spacer. |
| | Excessive air pressure. | Reduce to adequate air pressure. |
| Tool operates, but no fastener is driven. | There is a jam. | Clear jam. |
| | Pusher spring weakened or damaged. | Replace pusher spring. |
| Fastener misfire (skips). | Worn bumper. | Replace bumper. |
| | Dirt in nose. | Clean. |
| | Dirt or damage prevents fasteners from moving freely in magazine. | Clean magazine. |
| | Inadequate air flow to tool. | Check fitting hose of air compressor. |
| | Worn o-ring on piston or lack of lubrication. | Replace o-ring or lubricate. |
| | Damaged o-ring in trigger valve. | Replace o-rings. |
| | Air leaks. | Tighten screws and fittings. |
| Air leaks between housing and nose. | Cap seal leaking. | Replace seal. |
| | Loose screws in housing. | Tighten screws. |
| | Damaged o-rings. | Replace o-rings. |
| Sluggish operation or power loss. | Damaged bumper. | Replace bumper. |
| | Tool not lubricated sufficiently. | Lubricate tool. |
| | Worn out o-rings. | Replace o-rings. |
| Fastener jamming. | Exhaust port in cap is blocked. | Replace damaged internal parts. |
| | Driver guide worn or damaged. | Replace driver guide. |
| | Fastener size not correct. | Fasteners recommended for tool must be used. |
| | Fasteners are bent. | Replace with undamaged fasteners. |
| Air leaks at trigger valve area | Magazine or nose screws loose. | Tighten screws. |
| | O-rings in trigger valve are damaged. | Replace o-rings. |

GreX Power Tools One Year Limited Warranty

GreX Power Tools warrants its professional power tools are to be free of defects from workmanship and material for a period of one year from the date of original date of purchase (exceptions: rubber o-rings, bumpers, seals & driver blades). We will repair or replace at our option, any parts of the product and accessories covered under this warranty, which after examination, proves to be defective in workmanship or material during the warranty period. For repair or replacement, contact GreX directly. Proof of purchase may be required.

This warranty does not apply to repair or replacement required due to misuse, abuse, normal wear and tear or repairs and alterations attempted or made by other than our Service Center or Authorized Service Stations. In no event shall GreX be liable for any indirect, incidental, or consequential damage from the sale or use of this product. This disclaimer applies both during and after the term of warranty.

This is the only warranty and our company makes no warranties expressed or implied, including merchantability and fitness for a particular purpose, after the one year term of this warranty.

This limited warranty gives you specific rights, and you may also have other rights, which vary from state to state.

All information, text and images contained in this publication are the property of GreX Power Tools. Unauthorized distribution, duplication, appropriation or reproduction in whole or in part is strictly prohibited.

© 2009 GreX Power Tools. All Rights Reserved.

GREX POWER TOOLS

705 South Electric Avenue, Alhambra, CA 91803
Tel. 626-289-7618 Fax. 626-289-8121
www.greXusa.com