

HILTI

Hilti Corporation
 LI-9494 Schaan
 Tel.: +423 / 234 21 11
 Fax: +423 / 234 29 65
 www.hilti.com

HILTI

DCH 230/
 DCH 180-SL

Operating instructions en
 Mode d'emploi fr
 Manual de instrucciones es
 Manual de instruções pt



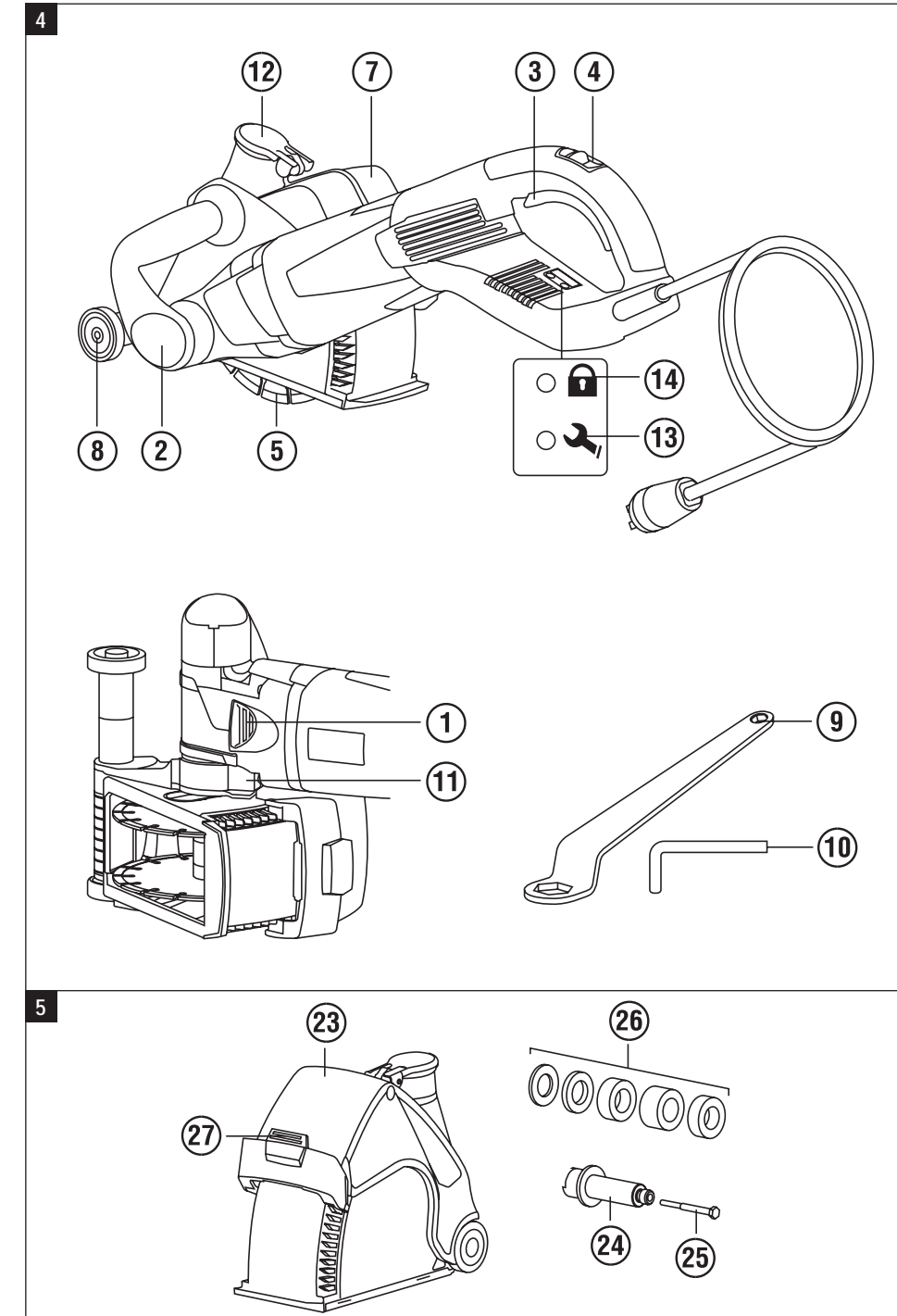
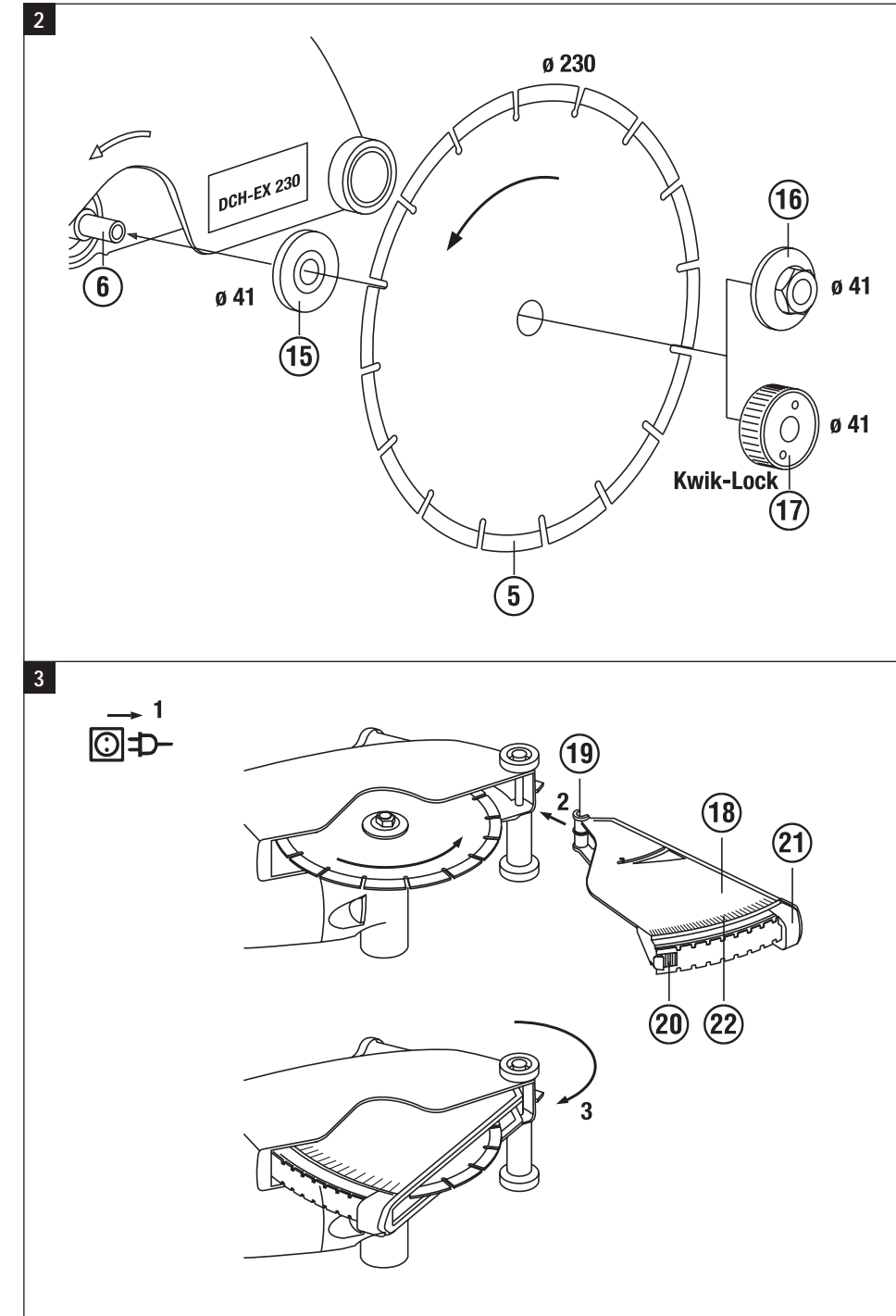
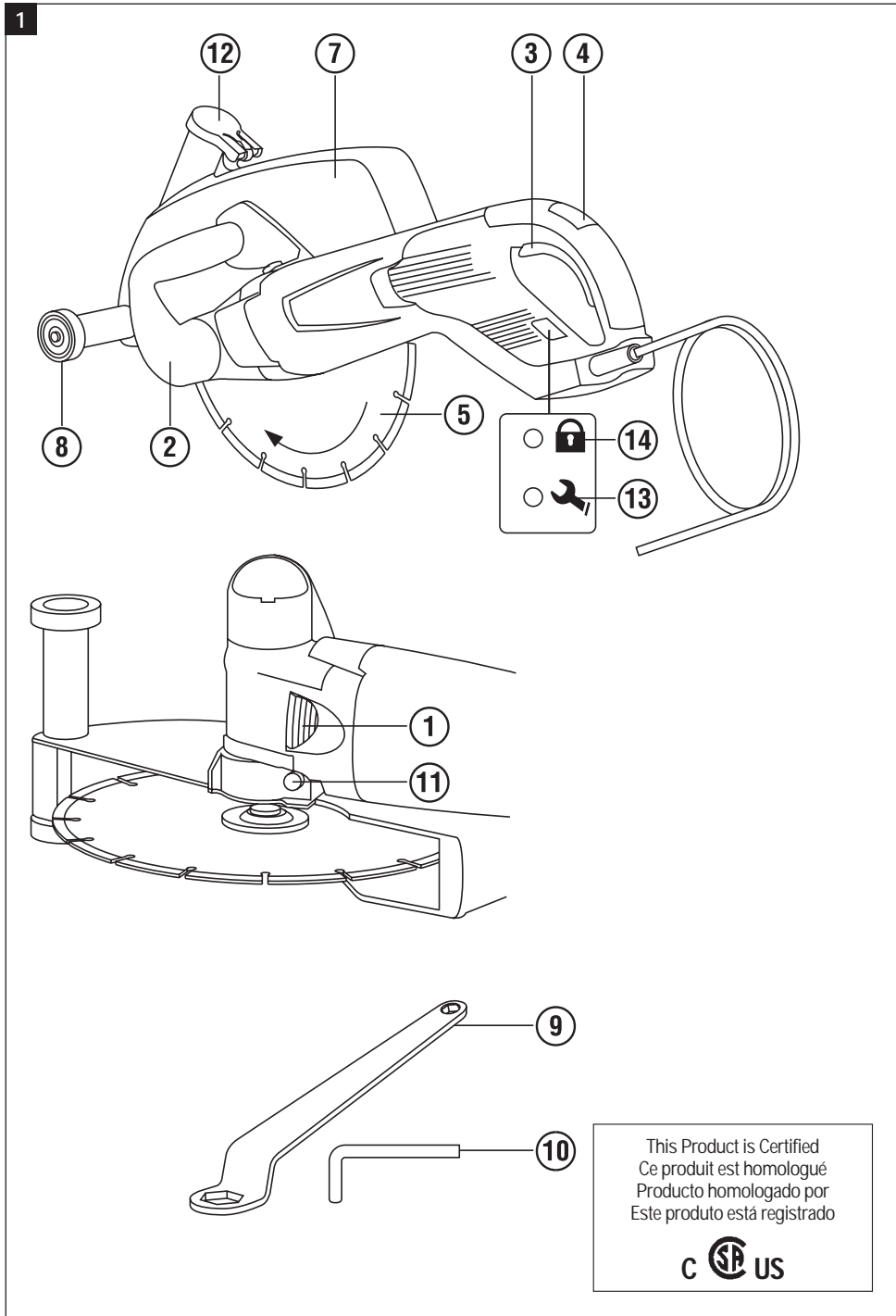

DCH 230/ DCH 180-SL Diamond cutter

It is essential that the operating instructions are read before the machine is operated for the first time.

Always keep these operating instructions together with the machine.

Ensure that the operating instructions are with the machine when it is given to other persons.

Contents	Page
1. General information	2
2. Description	3
3. Accessories	5
4. Technical data	6
5. Safety instructions	6
6. Before use	11
7. Operation	14
8. Care and maintenance	16
9. Troubleshooting	17
10. Disposal	18
11. Manufacturer's warranty	18

1 These numbers refer to the corresponding illustrations. The illustrations can be found on the fold-out cover pages. Keep these pages open while studying the operating instructions.

In these operating instructions, the designation "power tool" always refers to the DCH 230 and/or DCH 180-SL diamond cutters.

DCH 230 operating controls and indicators 1

- ① Spindle lockbutton
- ② Front grip
- ③ On / off switch
- ④ Switch-on interlock release button
- ⑤ Diamond cutting disc
- ⑥ Spindle
- ⑦ DCH-EX 230 guard
- ⑦ Guard (hood)

- ⑧ Guide wheels
- ⑨ Clamping nut wrench, 24 mm AF / 10 mm AF
- ⑩ Hex. socket wrench, 6 mm AF
- ⑪ Guard (hood) clamping screw
- ⑫ Dust removal connector cap
- ⑬ Service indicator
- ⑭ Theft protection indicator (option)

DCH 230 mounting system 2

- ⑮ Clamping flange, 41 mm dia., with O-ring
- ⑯ M 14 clamping nut
- ⑰ Kwik-Lock quick-release clamping nut (optional)

Depth gauge (option for the DCH 230) 3

- ⑱ Hood extension
- ⑲ Hook
- ⑳ Stop
- ㉑ Cutting depth sliding indicator
- ㉒ Cutting depth scale

DCH 180-SL operating controls and indicators 4

- ① Spindle lockbutton
- ② Front grip
- ③ On / off switch
- ④ Switch-on interlock release button
- ⑤ Diamond cutting disc
- ⑥ Spindle
- ⑦ DCH-EX 180-SL slitting hood
- ⑧ Guide wheels
- ⑨ Clamping nut wrench, 24 mm AF / 10 mm AF
- ⑩ Hex. socket wrench, 6 mm AF
- ⑪ Guard (hood) clamping screw
- ⑫ Dust removal connector cap
- ⑬ Service indicator
- ⑭ Theft protection indicator (option)

Parts of the DCH 180-SL 5

- ㉓ DCH-EX 180-SL slitting hood
- ㉔ Spindle extension
- ㉕ M 6 x 65 screw
- ㉖ Spacer ring
- ㉗ Hood extension release catch / cutting depth adjustment

en

1. General information

1.1 Safety notices and their meaning

en

DANGER

Draws attention to imminent danger that could lead to serious bodily injury or fatality.

WARNING

Draws attention to a potentially dangerous situation that could lead to serious personal injury or fatality.

CAUTION

Draws attention to a potentially dangerous situation that could lead to slight personal injury or damage to the equipment or other property.

NOTE

Draws attention to an instruction or other useful information.

1.2 Explanation of the pictograms and other information

Warning signs



General warning



Warning: electricity

Obligation signs



Wear a hard hat.



Wear eye protection.



Wear ear protection.



Wear protective gloves.



Wear safety shoes.



Wear breathing protection.

Symbols



Read the operating instructions before use.



Return waste material for recycling.

A

Amps

V

Volts



Alternating current

/min

Revolutions per minute

∅

Diameter

n_0

Nominal speed under no load



Double insulated

Location of identification data on the machine

The type designation and serial number can be found on the type identification plate on the machine. Make a note of this data in your operating instructions and always refer to it when making an enquiry to your Hilti representative or service department.

Type: _____

Generation: 01 _____

Serial no.: _____



2. Description

2.1 Use of the product as directed

The DCH 230 is an electrically-powered diamond cutter and the DCH 180-SL is an electrically-powered diamond slitting tool, both designed for professional use in the construction industry.

The DCH 230 is designed for cutting mineral materials using diamond cutting discs without water and can also be used for cutting metals when fitted with a synthetic resin-bonded fiber-reinforced cutting disc.

The DCH 180-SL is designed for slitting mineral materials using diamond cutting discs without water.

A vacuum cleaner with the appropriate filter, e.g. Hilti VCD 50 vacuum cleaner, must be used when cutting mineral materials.

In order to avoid electrostatic effects, a vacuum cleaner equipped with an antistatic hose should be used.

Use only diamond cutting discs with a maximum permissible peripheral speed of at least 80 m/sec (16000 ft/min) or synthetic resin-bonded fiber-reinforced cutting discs with a maximum permissible peripheral speed of at least 80 m/sec (16000 ft/min).

The power tool is to be used exclusively in pushing mode (counter rotation).

The use of liquids, e.g. to cool the disc or suppress dust, is not permissible.

Do not use the power tool for cutting with cutting tools of a type not specified in these operating instructions (e.g. circular saw blades) or for grinding.

The working environment may be as follows: construction site, workshop, renovation, conversion or new construction.

To avoid the risk of injury, use only genuine Hilti accessories and cutting tools.

Observe the safety rules and operating instructions for the accessories used.

Observe the information printed in the operating instructions concerning operation, care and maintenance.

The machine is designed for professional use and may be operated, serviced and maintained only by trained, authorized personnel. This personnel must be informed of any special hazards that may be encountered. The machine and its ancillary equipment may present hazards when used incorrectly by untrained personnel or when used not as directed.

The machine may be used only in a dry environment.

The machine may be operated only when connected to a power supply providing a voltage and frequency in compliance with the information given on its type identification plate.

Do not use the machine where there is a risk of fire or explosion.

Working on materials hazardous to the health (e.g. asbestos) is not permissible.

Modification of the machine or tampering with its parts is not permissible.

2.2 Switches

On/off switch with switch-on interlock

2.3 Starting current limitation

The starting current drawn by the power tool is several times higher than its rated current. The electronic starting current limiter reduces the starting current drawn by the power tool and thus prevents the mains fuse blowing. It also allows the power tool to start smoothly, without a jolt.

2.4 Restart interlock

The power tool does not restart by itself after an interruption in the electric supply. The switch must first be released and then pressed again after approx. 1 second.

2.5 TPS theft protection system (optional)

The power tool may be optionally equipped with the TPS theft protection system. If equipped with this feature, the power tool can be unlocked and made ready for operation only through use of the corresponding TPS key.

en



2.6 LED indicators

Service indicator LED (see section "Care and maintenance / service indicator")

Theft protection system indicator (optional) (see section "Operation / TPS theft protection system (optional)")

en

2.7 Guard (hood) with guide wheels

Cutting and slitting work on mineral materials may be carried out only when the power tool is equipped with a dust removal hood with guide wheels.

2.8 Electronic overload protection

The electronic overload protection system monitors current input and thus protects the power tool from overload.

If the motor is overloaded through application of excessive working pressure, the power tool's performance drops noticeably or it may come to a complete standstill. A standstill should be avoided.

Permissible overload cannot be given as a specific value as it depends on the temperature of the motor.

If the power tool has been overloaded, release the pressure applied and then allow it to run under no load for approx. 30 seconds.

2.9 Using extension cords

Use only extension cords of a type approved for the application and with conductors of adequate gauge. The power tool may otherwise lose performance and the extension cord may overheat. Check the extension cord for damage at regular intervals. Replace damaged extension cords.

Recommended minimum conductor gauge (cross section) and max. cable lengths

Conductor cross section	14 AWG	12 AWG
Mains voltage 110-120 V	-	125 ft

Do not use extension cords with 16 AWG conductor cross section.

2.10 Using extension cords outdoors

When working outdoors, use only extension cords that are approved and correspondingly marked for this application.

2.11 Using a generator or transformer

This tool may be powered by a generator or transformer when the following conditions are fulfilled: The unit must provide a power output in watts of at least twice the value printed on the type identification plate on the power tool. The operating voltage must remain within +5% and -15% of the rated voltage at all times, frequency must be in the 50 – 60 Hz range and never above 65 Hz, and the unit must be equipped with automatic voltage regulation and starting boost.

Never operate other power tools or appliances from the generator or transformer at the same time. Where applicable, use a generator or transformer designed for simultaneous power tool and vacuum cleaner operation. Switching other power tools or appliances on and off may cause undervoltage and / or overvoltage peaks, resulting in damage to the power tool.

2.12 Depth gauge (option for the DCH 230)

The DCH 230 can also be fitted with an optional depth gauge. This improves dust removal performance for cutting mineral materials. The desired maximum cutting depth can be set with the aid of the cutting depth scale on the hood extension.

The depth gauge is standard equipment with the DCH 180-SL.

2.13 Kwik-Lock clamping nut for cutting discs (optional, only for the DCH 230)

The Kwik-Lock nut can be used instead of the 41 mm dia. clamping nut. No tools are then required for changing cutting discs.

2.14 Items supplied as standard with the DCH 230

- 1 Power tool with DCH-EX 230 hood
- 1 Clamping flange, 41 mm dia., with O-ring
- 1 M 14 clamping nut
- 1 Clamping nut wrench, 24 mm AF / 10 mm AF
- 1 Hex. socket wrench, 6 mm AF
- 1 Cardboard box
- 1 Operating instructions

en

2.15 Items supplied as standard with the DCH 180-SL

- 1 DCH-EX 180-SL with dust hood and depth gauge
- 5 Spacer ring (3 mm, 6 mm, 2 x 13 mm, 21 mm)
- 1 M 14 clamping nut
- 1 Clamping nut wrench, 24 mm AF / 10 mm AF
- 1 Hex. socket wrench, 6 mm AF
- 1 Cardboard box
- 1 Operating instructions

2.16 Cutting disc specifications

Diamond cutting discs in compliance with ANSI B7.1 are to be used with the DCH 230 and DCH 180-SL. Synthetic resin-bonded fiber-reinforced cutting discs in compliance with ANSI B7.1 (cutting-off wheels of the straight, not offset type) may also be used with the DCH 230 for working on metals. The mounting instructions issued by the disc manufacturer must also be observed.

3. Accessories

DCH 230 / 180-SL conversion set	DCH-EX 180-SL slitting hood, comprising; spindle extension; M 6 x65 screw; 5 spacer rings (3 mm, 6 mm, 2 x 13 mm, 21 mm)
Kwik-Lock clamping nut (only for the DCH 230)	
Key for quick-release clamping nut	
Depth gauge for the DCH 230	
Vacuum cleaner	VCD 50
Antistatic hose, complete	Length 5 m (16.4 ft), Ø36 mm
Hilti toolbox	

4. Technical data

Right of technical changes reserved.

en

Other information about the power tool	DCH 230	DCH 180-SL
Rated voltage	120 V	120 V
Rated current input	20 A	20 A
Mains frequency	60 Hz	60 Hz
Dimensions (L x W x H)	670 mm (26.38 in) x 240 mm (9.45 in) x 210 mm (8.27 in)	620 mm (24.41 in) x 275 mm (10.83 in) x 185 mm (7.28 in)
Drive spindle thread	M 14	M 14
Disc arbor size	22.2 mm (0.87 in)	22.2 mm (0.87 in)
Cutting disc	Ø Max. 230 mm (9")	Ø Max. 180 mm (7")
Cutting disc thickness	Max. 3 mm (Max. 0.12 in)	Max. 3 mm (Max. 0.12 in)
Weight of the power tool	8.6 kg (18.96 lb)	9.2 kg (20.28 lb)
Protection class	Protection class I (grounded) or protection class II (double insulated). See type identification plate.	Protection class I (grounded) or protection class II (double insulated). See type identification plate.
Rated speed under no load	Max. 6,500/min	Max. 6,500/min
Clamping nut tightening torque	M14: 30 Nm (22 lb/ft)	M14: 30 Nm (22 lb/ft)
Spindle extension tightening torque		9 Nm (7 lb/ft)

5. Safety instructions

5.1 General power tool safety warnings

WARNING! Read all safety warnings and all instructions. Failure to follow the warnings and instructions may result in electric shock, fire and/or serious injury. **Save all warnings and instructions for future reference.** The term "power tool" in the warnings refers to your mains-operated (corded) power tool or battery-operated (cordless) power tool.

5.1.1 Work area safety

- Keep work area clean and well lit.** Cluttered or dark areas invite accidents.
- Do not operate power tools in explosive atmospheres, such as in the presence of flammable liquids, gases or dust.** Power tools create sparks which may ignite the dust or fumes.
- Keep children and bystanders away while operating a power tool.** Distractions can cause you to lose control.

5.1.2 Electrical safety

- Power tool plugs must match the outlet. Never modify the plug in any way. Do not use any adapter plugs with earthed (grounded) power tools.** Unmodified plugs and matching outlets will reduce risk of electric shock.
- Avoid body contact with earthed or grounded surfaces, such as pipes, radiators, ranges and refrigerators.** There is an increased risk of electric shock if your body is earthed or grounded.
- Do not expose power tools to rain or wet conditions.** Water entering a power tool will increase the risk of electric shock.
- Do not abuse the cord. Never use the cord for carrying, pulling or unplugging the power tool. Keep cord away from heat, oil, sharp edges or moving parts.** Damaged or entangled cords increase the risk of electric shock.

- e) **When operating a power tool outdoors, use an extension cord suitable for outdoor use.** Use of a cord suitable for outdoor use reduces the risk of electric shock.
- f) **If operating a power tool in a damp location is unavoidable, use a residual current device (RCD) protected supply.** Use of an RCD reduces the risk of electric shock.

5.1.3 Personal safety

- a) **Stay alert, watch what you are doing and use common sense when operating a power tool. Do not use a power tool while you are tired or under the influence of drugs, alcohol or medication.** A moment of inattention while operating power tools may result in serious personal injury.
- b) **Use personal protective equipment. Always wear eye protection.** Protective equipment such as dust mask, non-skid safety shoes, hard hat, or hearing protection used for appropriate conditions will reduce personal injuries.
- c) **Prevent unintentional starting. Ensure the switch is in the off-position before connecting to power source and/or battery pack, picking up or carrying the tool.** Carrying power tools with your finger on the switch or energising power tools that have the switch on invites accidents.
- d) **Remove any adjusting key or wrench before turning the power tool on.** A wrench or a key left attached to a rotating part of the power tool may result in personal injury.
- e) **Do not overreach. Keep proper footing and balance at all times.** This enables better control of the power tool in unexpected situations.
- f) **Dress properly. Do not wear loose clothing or jewellery. Keep your hair, clothing and gloves away from moving parts.** Loose clothes, jewellery or long hair can be caught in moving parts.
- g) **If devices are provided for the connection of dust extraction and collection facilities, ensure these are connected and properly used.** Use of dust collection can reduce dust-related hazards.

5.1.4 Power tool use and care

- a) **Do not force the power tool. Use the correct power tool for your application.** The correct power tool will do the job better and safer at the rate for which it was designed.
- b) **Do not use the power tool if the switch does not turn it on and off.** Any power tool that cannot be

controlled with the switch is dangerous and must be repaired.

- c) **Disconnect the plug from the power source and/or the battery pack from the power tool before making any adjustments, changing accessories, or storing power tools.** Such preventive safety measures reduce the risk of starting the power tool accidentally.
- d) **Store idle power tools out of the reach of children and do not allow persons unfamiliar with the power tool or these instructions to operate the power tool.** Power tools are dangerous in the hands of untrained users.
- e) **Maintain power tools. Check for misalignment or binding of moving parts, breakage of parts and any other condition that may affect the power tool's operation. If damaged, have the power tool repaired before use.** Many accidents are caused by poorly maintained power tools.
- f) **Keep cutting tools sharp and clean.** Properly maintained cutting tools with sharp cutting edges are less likely to bind and are easier to control.
- g) **Use the power tool, accessories and tool bits etc. in accordance with these instructions, taking into account the working conditions and the work to be performed.** Use of the power tool for operations different from those intended could result in a hazardous situation.

5.1.5 Service

- a) **Have your power tool serviced by a qualified repair person using only identical replacement parts.** This will ensure that the safety of the power tool is maintained.

5.2 Safety instructions for all operations

5.2.1 Safety warnings for abrasive cutting-off operations

- a) **This power tool is intended to function as a cut-off tool. Read all safety warnings, instructions, illustrations and specifications provided with this power tool.** Failure to follow all instructions listed below may result in electric shock, fire and/or serious injury.
- b) **Operations such as grinding, sanding, wire brushing or polishing are not recommended to be performed with this power tool.** Operations for which the power tool was not designed may create a hazard and cause personal injury.

en

en

- c) **Do not use accessories which are not specifically designed and recommended by the tool manufacturer.** Just because the accessory can be attached to your power tool, it does not assure safe operation.
- d) **The rated speed of the accessory must be at least equal to the maximum speed marked on the power tool.** Accessories running faster than their rated speed can break and fly apart.
- e) **The outside diameter and the thickness of your accessory must be within the capacity rating of your power tool.** Incorrectly sized accessories cannot be adequately guarded or controlled.
- f) **The arbour size of wheels, flanges, backing pads or any other accessory must properly fit the spindle of the power tool.** Accessories with arbour holes that do not match the mounting hardware of the power tool will run out of balance, vibrate excessively and may cause loss of control.
- g) **Do not use a damaged accessory. Before each use inspect the accessory such as abrasive wheels for chips and cracks, wire brush for loose or cracked wires. If power tool or accessory is dropped, inspect for damage or install an undamaged accessory. After inspecting and installing an accessory, position yourself and bystanders away from the plane of the rotating accessory and run the power tool at maximum no-load speed for one minute.** Damaged accessories will normally break apart during this test time.
- h) **Wear personal protective equipment. Depending on application, use face shield, safety goggles or safety glasses. As appropriate, wear dust mask, hearing protectors, gloves and workshop apron capable of stopping small abrasive or workpiece fragments.** The eye protection must be capable of stopping flying debris generated by various operations. The dust mask or respirator must be capable of filtrating particles generated by your operation. Prolonged exposure to high intensity noise may cause hearing loss.
- i) **Keep bystanders a safe distance away from work area. Anyone entering the work area must wear personal protective equipment.** Fragments of workpiece or of a broken accessory may fly away and cause injury beyond immediate area of operation.
- j) **Hold power tool by insulated gripping surfaces only, when performing an operation where the cutting accessory may contact hidden wiring or its own cord.** Cutting accessory contacting a “live” wire may make exposed metal parts of the power tool “live” and shock the operator.
- k) **Position the cord clear of the spinning accessory.** If you lose control, the cord may be cut or snagged and your hand or arm may be pulled into the spinning accessory.
- l) **Never lay the power tool down until the accessory has come to a complete stop.** The spinning accessory may grab the surface and pull the power tool out of your control.
- m) **Do not run the power tool while carrying it at your side.** Accidental contact with the spinning accessory could snag your clothing, pulling the accessory into your body.
- n) **Regularly clean the power tool's air vents.** The motor's fan will draw the dust inside the housing and excessive accumulation of powdered metal may cause electrical hazards.
- o) **Do not operate the power tool near flammable materials.** Sparks could ignite these materials.
- p) **Do not use accessories that require liquid coolants.** Using water or other liquid coolants may result in electrocution or shock.

5.2.2 Further safety instructions for all operations

Kickback and related warnings

Kickback is a sudden reaction to a pinched or snagged rotating wheel. Pinching or snagging causes rapid stalling of the rotating accessory which in turn causes the uncontrolled power tool to be forced in the direction opposite of the accessory's rotation at the point of the binding.

For example, if an abrasive wheel is snagged or pinched by the workpiece, the edge of the wheel that is entering into the pinch point can dig into the surface of the material causing the wheel to climb out or kick out. The wheel may either jump toward or away from the operator, depending on direction of the wheel's movement at the point of pinching. Abrasive wheels may also break under these conditions.

Kickback is the result of power tool misuse and/or incorrect operating procedures or conditions and can be avoided by taking proper precautions as given below.

- a) **Maintain a firm grip on the power tool and position your body and arm to allow you to resist kickback forces. Always use auxiliary handle, if provided, for maximum control over kickback**

or torque reaction during start-up. The operator can control torque reactions or kickback forces, if proper precautions are taken.

- b) **Never place your hand near the rotating accessory.** Accessory may kickback over your hand.
- c) **Do not position your body in the area where power tool will move if kickback occurs.** Kickback will propel the tool in direction opposite to the wheel's movement at the point of snagging.
- d) **Use special care when working corners, sharp edges, etc. Avoid bouncing and snagging the accessory.** Corners, sharp edges or bouncing have a tendency to snag the rotating accessory and cause loss of control or kickback.
- e) **Do not attach a saw chain woodcarving blade or toothed saw blade.** Such blades create frequent kickback and loss of control.

5.2.3 Safety warnings specific for abrasive cutting-off operations

- a) **Use only wheel types that are recommended for your power tool and the specific guard designed for the selected wheel.** Wheels for which the power tool was not designed cannot be adequately guarded and are unsafe.
- b) **The guard must be securely attached to the power tool and positioned for maximum safety, so the least amount of wheel is exposed towards the operator.** The guard helps to protect operator from broken wheel fragments and accidental contact with wheel.
- c) **Wheels must be used only for recommended applications. For example: do not grind with the side of cut-off wheel.** Abrasive cut-off wheels are intended for peripheral grinding, side forces applied to these wheels may cause them to shatter.
- d) **Always use undamaged wheel flanges that are of correct size and shape for your selected wheel.** Proper wheel flanges support the wheel thus reducing the possibility of wheel breakage. Flanges for cut-off wheels may be different from grinding wheel flanges.
- e) **Do not use worn down wheels from larger power tools.** Wheel intended for larger power tool is not suitable for the higher speed of a smaller tool and may burst.

5.2.4 Additional safety warnings specific for abrasive cutting-off operations

- a) **Do not "jam" the cut-off wheel or apply excessive pressure. Do not attempt to make an excessive**

depth of cut. Overstressing the wheel increases the loading and susceptibility to twisting or binding of the wheel in the cut and the possibility of kickback or wheel breakage.

- b) **Do not position your body in line with and behind the rotating wheel.** When the wheel, at the point of operation, is moving away from your body, the possible kickback may propel the spinning wheel and the power tool directly at you.
- c) **When wheel is binding or when interrupting a cut for any reason, switch off the power tool and hold the power tool motionless until the wheel comes to a complete stop. Never attempt to remove the cut-off wheel from the cut while the wheel is in motion otherwise kickback may occur.** Investigate and take corrective action to eliminate the cause of wheel binding.
- d) **Do not restart the cutting operation in the workpiece. Let the wheel reach full speed and carefully reenter the cut.** The wheel may bind, walk up or kickback if the power tool is restarted in the workpiece.
- e) **Support panels or any oversized workpiece to minimize the risk of wheel pinching and kickback.** Large workpieces tend to sag under their own weight. Supports must be placed under the workpiece near the line of cut and near the edge of the workpiece on both sides of the wheel.
- f) **Use extra caution when making a "pocket cut" into existing walls or other blind areas.** The protruding wheel may cut gas or water pipes, electrical wiring or objects that can cause kickback.

5.3 Safety instruction for all operations

5.3.1 Safety instructions for all operations

- a) **Do not use wheels that require liquid coolants.** Using water or other liquid coolants may result in electrocution or shock.
- b) **Use only wheel types that are recommended for your power tool and the specific guard designed for the selected wheel.** Wheels for which the power tool was not designed cannot be adequately guarded and are unsafe.

5.3.2 Personal safety

- a) **Always hold the machine securely with both hands on the grips provided. Keep the grips dry, clean and free from oil and grease.**
- b) **Breathing protection must be worn if the power tool is used without a dust extraction system for**

en

en

- work that creates dust. Close the cap over the dust removal connector.
- c) **Improve the blood circulation in your fingers by relaxing your hands and exercising your fingers during breaks between working.**
 - d) **Avoid touching rotating parts. Switch the power tool on only after bringing it into position at the workpiece.** Touching rotating parts, especially rotating drill bits, discs or blades, etc. may lead to injury.
 - e) **Always lead the supply cord and extension cord away from the power tool to the rear while working.** This helps to avoid tripping over the cord while working.
 - f) **The guard must always be fitted when the power tool is used for cutting metals. Close the cap over the dust removal connector.**
 - g) **If the work involves breaking right through, take the appropriate safety measures at the opposite side.** Parts breaking away could fall out and / or fall down and injure other persons.
 - h) **Children must be instructed not to play with the appliance.**
 - i) **The appliance is not intended for use by children, by debilitated persons or those who have received no instruction or training.**
 - j) **Do not use the power tool if it starts with a jolt.** This may be an indication that the electronic control unit is defective and that the power tool can no longer be controlled in the usual way. Have the tool repaired at an authorized Hilti service center right away.
 - k) **WARNING: Some dust created by grinding, sanding, cutting and drilling contains chemicals known to cause cancer, birth defects, infertility or other reproductive harm; or serious and permanent respiratory or other injury.** Some examples of these chemicals are: lead from lead-based paints, crystalline silica from bricks, concrete and other masonry products and natural stone, arsenic and chromium from chemically-treated lumber. Your risk from these exposures varies, depending on how often you do this type of work. **To reduce exposure to these chemicals, the operator and bystanders should work in a well-ventilated area, work with approved safety equipment, such as respiratory protection appropriate for the type of dust generated, and designed to filter out microscopic particles and direct dust away from the face and body. Avoid prolonged contact with dust. Wear protective clothing and wash ex-**

posed areas with soap and water. Allowing dust to get into your mouth, nose, eyes, or to remain on your skin may promote absorption of harmful chemicals.

5.3.3 Power tool use and care

- a) **Cutting discs must be stored, handled and fitted carefully in accordance with the manufacturer's instructions.**
- b) **If use of a spacer ring or other intermediate part is specified and the part is supplied with the cutting disc, check to ensure that the part is fitted.**
- c) **Secure the workpiece. Use clamps or a vice to secure the workpiece.** The workpiece is thus held more securely than by hand and both hands remain free to operate the machine.
- d) **Before use, check that the cutting disc has been fitted correctly and the clamping nut tightened. Then allow the power tool to run for 30 seconds under no load while holding it in a secure position. Switch off the power tool immediately if significant vibration or any other faults are noticed. Should this occur, check the entire system in order to determine the cause.**
- e) **Take steps to ensure that flying sparks from the power tool do not present a hazard, i.e. by striking yourself or other persons. Adjust the position of the disc guard accordingly.**
- f) **Slits cut in loadbearing walls of buildings or other structures may influence the statics of the structure, especially when steel reinforcing bars or load-bearing components are cut through. Consult the structural engineer, architect, or person in charge of the building project before beginning the work.**
- g) **Guide the power tool carefully and make straight cuts in order to avoid jamming the cutting disc. Cutting curves is not permissible.**
- h) **Guide the power tool evenly and do not apply lateral pressure to the cutting disc. Always bring the power tool into contact with the workpiece at right angles. Do not attempt to alter the line of cut by applying lateral pressure or by bending the cutting disc while cutting is in progress.** This presents a risk of damaging or breaking the cutting disc.

5.4 Safety instruction for all operations

5.4.1 Electrical safety



- a) **Before beginning work, check the working area (e.g. using a metal detector) to ensure that no concealed electric cables or gas and water pipes are present.** External metal parts of the machine may become live, for example, when an electric cable is damaged accidentally. This presents a serious risk of electric shock.
- b) **Check the machine's supply cord at regular intervals and have it replaced by a qualified specialist if found to be damaged. Check extension cords at regular intervals and replace them if found to be damaged. Do not touch the supply cord or extension cord if it is damaged while working. Disconnect the supply cord plug from the power outlet.** Damaged supply cords or extension cords present a risk of electric shock.
- c) **Dirty or dusty machines which have been used frequently for work on conductive materials should be checked at regular intervals at a Hilti Service Center.** Under unfavorable circumstances, dampness or dust adhering to the surface of the machine, especially dust from

conductive materials, may present a risk of electric shock.

- d) **When working outdoors with a power tool check to ensure that the tool is connected to the electric supply by way of a ground fault circuit interrupter (GFCI) with a rating of max. 30 mA (tripping current).** Use of a ground fault circuit interrupter reduces the risk of electric shock.
- e) **Use of a ground fault circuit interrupter (GFCI) with a maximum tripping current of 30 mA is recommended.**

en

5.4.2 Work area safety

Ensure that the workplace is well ventilated. Exposure to dust at a poorly ventilated workplace may result in damage to the health.

5.4.3 Personal protective equipment

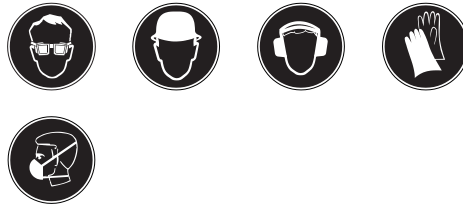

The user and any other persons in the vicinity must wear ANSI Z87.1-approved eye protection, a hard hat, ear protection, protective gloves and breathing protection while the machine is in use.

6. Before use



WARNING

The supply cord must be disconnected from the electric supply and the cutting disc or drive spindle must have come to a complete stop before attempting to change or adjust discs, parts of the tool or its accessories.

CAUTION

The mains voltage must comply with the specification given on the type identification plate. Ensure that the power tool is disconnected from the electric supply.

CAUTION

Wear protective gloves, especially when changing discs, adjusting the guard (hood) and when fitting the depth gauge.

6.1 Guard (hood)

WARNING

Never use the power tool without the guard (hood).

NOTE

If the guard (hood) clamping force is found to be inadequate, this can be increased by tightening the clamping screw slightly.

6.1.1 Fitting and adjusting the guard (hood) **6 7**

1. Disconnect the supply cord plug from the power outlet.
2. Use the hex. socket wrench to release the clamping screw.
3. Fit the guard (hood) onto the collar on the gearing section.
4. Rotate the guard (hood) into the desired position.
5. Use the hex. socket wrench to tighten the clamping screw.

6.1.2 Removing the guard (hood)

1. Disconnect the supply cord plug from the power outlet.
2. Use the hex. socket wrench to release the clamping screw.
3. Rotate the guard (hood) and pull it away from the tool.

6.2 Depth gauge (optional)

6.2.1 Fitting / removing the depth gauge for the DCH 230 **3**

1. Disconnect the supply cord plug from the power outlet.
2. Fit the hook over the guide wheel axle.
3. Pivot the hood extension into the hood until the catch is heard to engage.
4. To remove the hood extension, press the catch and pivot the hood extension down and away from the hood.

6.2.2 Using the depth gauge to set the cutting depth for the DCH 230

1. Press the cutting depth sliding indicator.
2. Move the cutting depth sliding indicator to the desired cutting depth.

6.2.3 Using the depth gauge to set the cutting depth for the DCH 180-SL

The depth gauge forms and integral part of the DCH 180-SL and cannot be removed.

1. Press the catch.
2. Set the desired cutting depth by adjusting the depth gauge.

6.3 Fitting a cutting disc

CAUTION

Use only cutting tools with a rated maximum permissible speed which is at least as high as the machine's highest no-load running speed.

CAUTION

Cutting discs which are damaged or out of round (causing vibration) must not be used.

CAUTION

Do not use synthetic resin-bonded fiber-reinforced cutting discs that have exceeded their use-by date.

CAUTION

The spindle extension may used only in conjunction with the DCH-EX 180-SL slitting hood.

NOTE

Diamond cutting discs in compliance with ANSI B7.1 are to be used with the DCH 230 and DCH 180-SL. Synthetic resin-bonded fiber-reinforced cutting discs in compliance with ANSI B7.1 (cutting-off wheels of the straight, not offset type) may also be used with the DCH 230 for working on metals. The mounting instructions issued by the disc manufacturer must also be observed.

6.3.1 Fitting diamond cutting discs and synthetic resin-bonded fiber-reinforced cutting discs to the DCH 230

1. Disconnect the supply cord plug from the power outlet.
2. Clean the clamping flange and the clamping nut.
3. **CAUTION** The clamping flange is equipped with an O-ring. **If this O-ring is missing, the clamping flange must be replaced.**
Place the 41 mm dia. clamping flange on the spindle so that it cannot rotate.
4. Place the cutting disc on the centering collar of the clamping flange.
5. Fit the clamping nut.
6. **CAUTION** **Do not press the spindle lockbutton before the drive spindle has stopped rotating.**
Press the spindle lockbutton and hold it in this position.

7. Use the wrench to tighten the clamping nut securely and then release the spindle lockbutton.
8. Check to ensure that the spindle lockbutton has disengaged.

6.3.2 Using the Kwik-Lock nut to fit cutting discs (only for the DCH 230)

NOTE

The Kwik-Lock nut may be used instead of the standard clamping nut. No tools are then required for fitting/changing the cutting discs.

NOTE

The arrow on the upper surface of the nut must be within the index marks. If the arrow is not within the index marks when the nut is tightened it will be impossible to release the nut by hand. Should it be necessary, use the key to release the Kwik-Lock nut (do not use a pipe wrench!).

1. Disconnect the supply cord plug from the power outlet.
2. Clean the clamping flange and the quick release clamping nut.
3. **CAUTION** The clamping flange is equipped with an O-ring. **If this O-ring is missing, the clamping flange must be replaced.**
Place the 41 mm dia. clamping flange on the spindle so that it cannot rotate.
4. Place the cutting disc on the centering collar of the clamping flange.
5. Screw the quick-release clamping nut onto the spindle until it contacts the cutting disc (the side with the lettering should be visible after the nut is screwed on).
6. **CAUTION Do not press the spindle lockbutton before the drive spindle has stopped rotating.**
Press the spindle lockbutton and hold it in this position.
7. Turn the cutting disc firmly by hand in a clockwise direction until the quick-release clamping nut is tightened securely.
8. Release the spindle lockbutton.
9. Check to ensure that the spindle lockbutton has disengaged.

6.3.3 Fitting cutting discs to the DCH 180-SL slitting tool

NOTE

Use of the Kwik-Lock nut with the DCH 180-SL slitting tool is not permissible.

1. Disconnect the supply cord plug from the power outlet.
2. Press the catch and pivot the hood extension down and away from the hood.
3. Place the first diamond disc on the spindle extension.
4. Fit the spacer ring corresponding to the desired slitting width.
5. Fit the second diamond cutting disc.
NOTE To achieve the maximum slitting width, all spacer rings have to be positioned between the diamond discs.
NOTE All the spacer rings thus have to be fitted.
6. **CAUTION Do not press the spindle lockbutton before the drive spindle has stopped rotating.**
Press the spindle lockbutton and hold it in this position.
7. Screw the clamping nut onto the drive spindle and tighten it securely with the wrench.
8. Release the spindle lockbutton.
9. Check to ensure that the spindle lockbutton has disengaged.
10. Press the catch to release the hood extension and allow it to be pushed in and, at the same time, set to the desired cutting depth.

6.4 Removing the cutting disc from the tool

To remove the cutting disc from the tool, follow the instructions for fitting the disc but carry out the steps in the reverse order.

6.5 Instructions for converting the DCH 230 to a DCH 180-SL

1. Disconnect the supply cord plug from the power outlet.
2. To remove the depth gauge (optional), press the catch and pivot the combined hood extension / depth gauge out of the hood.
3. Press the spindle lockbutton.
4. Use a wrench to release and remove the M 14 clamping nut or remove the Kwik-Lock nut by hand.
5. Remove the diamond cutting disc.
6. Remove the 41 mm diameter clamping flange from the spindle.
7. Use the 6 mm hex. socket wrench to release the hex. socket screw securing the hood.
8. Rotate the DCH-EX 230 guard (hood) and pull it away from the tool.

en

en

9. Check that the set of parts required for the conversion is complete (DCH-EX 180-SL slitting hood, spindle extension, M 6 x 65 screw, 5 spacer rings (3 mm, 6 mm 2 x 13 mm, 21 mm)).
10. Fit the DCH-EX 180-SL slitting hood onto the spindle collar.
11. Rotate the guard (hood) into the desired position.
12. Use the hex. socket wrench to tighten the hex. socket screw.
13. Press the catch and pivot the hood extension down and away from the hood.
14. Place the spindle extension on the spindle so that it cannot rotate.
15. Fit the M 6 x 65 screw through the spindle extension.
16. Press the spindle lockbutton.
17. Secure the spindle extension on the spindle with the M 6 x 65 screw and tighten the screw with the 10 mm AF wrench.
18. From here on, follow the instructions for fitting the cutting discs to the slitting tool.
NOTE The procedure for fitting the cutting discs is described in the section "Fitting cutting discs to the DCH 180-SL slitting tool".

6.6 Instructions for converting the DCH 180-SL to a DCH 230

Items required for the conversion: DCH-EX 230 hood, 41 mm dia. clamping flange with O-ring, M 14 clamping nut; 24 mm AF / 10 mm AF wrench, 6 mm hex. socket wrench, diamond cutting discs max. 230 mm diameter.

1. Disconnect the supply cord plug from the power outlet.
2. Press the catch on the DCH-EX 180-SL hood and pull out the depth gauge.
3. Press the spindle lockbutton.
4. Use a 24 mm AF wrench to release the 41 mm diameter clamping nut and remove the nut from the spindle extension.
5. Release the spindle lockbutton.
6. Remove all spacer rings and both diamond cutting discs from the spindle extension.
7. Use the 10 mm AF wrench to release the M 6 x 65 screw and remove the screw.
8. Remove the spindle extension from the spindle.
9. Use the hex. socket wrench to release the slitting hood.
10. Rotate the slitting hood on the spindle collar and remove it.
11. The procedure for fitting the DCH-EX 230 guard and the corresponding cutting disc is described in the sections "Fitting and adjusting the guard" and "Fitting cutting discs".

6.7 Storing and transporting cutting discs

CAUTION

Remove the cutting disc from the power tool after use. The cutting disc may suffer damage if the power tool is transported with the disc fitted.

CAUTION

Store the cutting disc in accordance with the manufacturer's recommendations. Incorrect or careless storage may damage the cutting disc.

7. Operation



Hold tool by insulated gripping surfaces when performing an operation where the cutting tool may contact hidden wiring or its own cord. Contact with a "live" wire will make exposed metal parts of the tool "live" and shock the operator.

WARNING

Do not use the power tool if it starts with a jolt. This may be an indication that the electronic control unit is defective and that the power tool can no longer be controlled in the usual way. Have the tool repaired at an authorized Hilti service center right away.

CAUTION

The power tool and the cutting operation generate noise. **Wear ear protectors.** Exposure to noise can cause hearing loss.

CAUTION

The cutting operation may cause dangerous splinters. Splintering material presents a risk of injury to the eyes and body. **Wear eye protection and a hard hat.**

CAUTION

The direction of advance is important. The power tool must always be advanced with the guide wheels ahead and in contact with the material being cut. There is otherwise a risk of kick-back.

WARNING

The electric supply voltage must comply with the information given on the type identification plate on the power tool.

CAUTION

The cutting disc and parts of the power tool may get hot through use. There is a risk of burning your hands. **Wear protective gloves. Touch the power tool only at the grips provided.**

CAUTION

Use clamps or a vice to hold the workpiece securely.

WARNING

Slits cut in loadbearing walls of buildings or other structures may influence the statics of the structure, especially when steel reinforcing bars or load-bearing components are cut through. **Consult the structural engineer, architect, or person in charge of the building project before beginning the work.**

7.1 Working with the power tool

Take care to ensure that the closed side of the guard is always positioned toward the operator's body. Adjust the position of the guard (hood) to suit each cutting application.

7.2 TPS theft protection system (optional)

NOTE

The power tool may be equipped with the optional theft protection system. If the power tool is equipped with this feature, it can be unlocked and made ready for operation only with the corresponding TPS key.

7.2.1 Unlocking the power tool

1. Plug the supply cord into the power outlet. The yellow theft protection indicator LED blinks. The power tool is then ready to receive the signal from the TPS key.

2. Hold the TPS key against the lock symbol. The power tool is unlocked as soon as the yellow theft protection indicator LED no longer lights.

NOTE If, for example, the electric supply is briefly interrupted due to a power failure or disconnected when moving to a different workplace, the power tool remains ready for operation for approx. 20 minutes. In the event of a longer interruption, the TPS key must be used again to unlock the power tool.

7.2.2 Activation of the tool's theft protection system

NOTE

Further detailed information on activation and use of the theft protection system can be found in the operating instructions for the theft protection system.

7.3 Switching on

1. Plug the supply cord into the power outlet.
2. Always hold the tool securely with both hands on the grips provided.
3. Unlock the on / off switch by pressing the switch-on interlock release button.
4. Press the on / off switch.
5. Reposition your thumb around the rear grip.

7.4 Switching off

Release the on / off switch.

The tool stops after the on / off switch is released. The switch-on interlock is re-activated.

7.5 Working with diamond cutting discs (DCH 230 and DCH 180-SL) and synthetic resin-bonded fiber-reinforced cutting discs (only DCH 230)

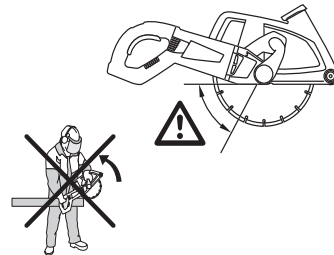

en

DANGER

To reduce the risk of kick-back, avoid bringing the cutting tool into contact with the material in the area indicated.

en

DANGER

Wherever possible, bring the guide wheels into contact with the workpiece before starting the cut. Take extra care in situations where this is not possible or where the cutting disc is inserted in an existing cut.

1. When cutting mineral materials, first bring the tool's guide wheels into contact with the object to be cut.
2. Allow the power tool to reach full speed.
3. Apply pressure to the power tool so that the cutting disc is pressed into the material slowly. This ensures that particles and sparks generated by the cutting operation are caught by the hood and extracted by the dust removal system.

NOTE Apply moderate pressure, adjusting the rate of advance to suit the material being cut.

NOTE The diamond disc may overheat and suffer damage when cutting very hard mineral materials, e.g. concrete with a high hard pebble content. A trail of sparks right round the circumference of the diamond cutting disc is a sure indication of this. Should this occur, stop cutting and cool the disc by allowing the tool to run under no load.

A drop in the rate of cutting progress can be an indication of "blunt" (polished) diamond segments. The segments can be resharpened by making a few cuts in an abrasive material (Hilti sharpening plate or sand-lime block).

7.6 Using a suitable vacuum cleaner for working on mineral materials

NOTE

Please read the operating instructions for the vacuum cleaner for information about disposal of the material collected.

Dust can be kept to a minimum when working by using a suitable vacuum cleaner (such as the Hilti VCD 50). Use of a vacuum cleaner also helps to cool the segments on the disc and thus reduces segment wear. In order to avoid electrostatic effects, a vacuum cleaner equipped with an antistatic hose should be used.

8. Care and maintenance

CAUTION

Disconnect the supply cord plug from the power outlet.

8.1 Care of the power tool

DANGER

Under extreme conditions, when used for working on metal, conductive dust may accumulate inside the tool. This may have an adverse effect on the tool's protective insulation. **Under such conditions, the tool should be plugged into a ground fault circuit interrupter (RCD) and use of a stationary**

dust removal system and frequent cleaning of the tool's cooling air slots is recommended.

The outer casing of the motor and the grips are made from impact-resistant plastic. Parts of the grips have a synthetic rubber covering.

Never operate the power tool when the ventilation slots are blocked. Clean the ventilation slots carefully using a dry brush. Do not permit foreign objects to enter the interior of the power tool. Clean the outside of the power tool at regular intervals with a slightly damp cloth. Do not use a spray, steam pressure

cleaning equipment or running water for cleaning. This may negatively affect the electrical safety of the

power tool. Always keep the grip surfaces of the power tool free from oil and grease. Do not use cleaning agents which contain silicone.

8.2 Service indicator

NOTE

The power tool is equipped with a service indicator.

LED indicators	Constant red light	End of service interval - servicing is due. After the lamp lights for the first time, the power tool may continue to be used for several hours (switched-on running time) before the automatic cut-out is activated. To ensure that the power tool is always ready for use, it should be returned to Hilti for servicing in good time.
	Blinking red light	See section "Troubleshooting".

8.3 Maintenance

WARNING

Repairs to the electrical section of the machine may be carried out only by trained electrical specialists.

Check all external parts of the power tool for damage at regular intervals and check that all controls operate faultlessly. Do not operate the power tool if parts

are damaged or when the controls do not function faultlessly. If necessary, the power tool should be repaired by Hilti Service.

8.4 Checking the power tool after care and maintenance

After carrying out care and maintenance, check that all protective and safety devices are fitted and that they function faultlessly.

9. Troubleshooting

Fault	Possible cause	Remedy
The power tool doesn't start.	Interruption in the electric supply.	Plug in another electric appliance and check whether it works.
	The supply cord or plug is defective.	Have checked by a trained electrical specialist and replaced if necessary.
	The power tool has not been unlocked (tools with optional theft protection system).	Use the TPS key to unlock the power tool.
	The on / off switch is defective.	If necessary, the power tool should be repaired by Hilti Service.
	The power tool has been overloaded (application limits exceeded).	Use the right power tool for the job (don't use a low-powered tool for heavy work).
	The overheating protection system is active.	Allow the power tool to cool down. Clean the ventilation slots.
	Other electrical fault.	Have it checked by a trained electrical specialist.

en

Fault	Possible cause	Remedy
The power tool doesn't start.	The electronic restart interlock is activated after an interruption in the electric supply.	Switch the power tool off and on again.
The power tool doesn't achieve full power.	The extension cord's conductor cross section is inadequate.	Use an extension cord with an adequate conductor cross section. (Please refer to "Before use".)
The power tool doesn't start and the service indicator blinks red.	A fault has occurred in the power tool.	If necessary, the power tool should be repaired by Hilti Service.
The power tool doesn't start and the service indicator lights red.	The carbon brushes are worn.	Have checked by a trained electrical specialist and replaced if necessary.
The power tool doesn't start and the theft protection system indicator blinks yellow.	The power tool has not been unlocked (tools with optional theft protection system).	Use the TPS key to unlock the power tool.

10. Disposal



Most of the materials from which Hilti machines or appliances are manufactured can be recycled. The materials must be correctly separated before they can be recycled. In many countries, Hilti has already made arrangements for taking back old machines and appliances for recycling. Ask Hilti customer service or your Hilti representative for further information.

11. Manufacturer's warranty

Hilti warrants that the tool supplied is free of defects in material and workmanship. This warranty is valid so long as the tool is operated and handled correctly, cleaned and serviced properly and in accordance with the Hilti Operating Instructions, and the technical system is maintained. This means that only original Hilti consumables, components and spare parts may be used in the tool.

This warranty provides the free-of-charge repair or replacement of defective parts only over the entire lifespan of the tool. Parts requiring repair or replacement as a result of normal wear and tear are not covered by this warranty.

Additional claims are excluded, unless stringent national rules prohibit such exclusion. In particular, Hilti is not obligated for direct, indirect, incidental or consequential damages, losses or expenses in connection with, or by reason of, the use of, or inability to use the tool for any purpose. Implied warranties of merchantability or fitness for a particular purpose are specifically excluded.

For repair or replacement, send the tool or related parts immediately upon discovery of the defect to the address of the local Hilti marketing organization provided.

This constitutes Hilti's entire obligation with regard to warranty and supersedes all prior or contemporaneous comments and oral or written agreements concerning warranties.