

### Parts List

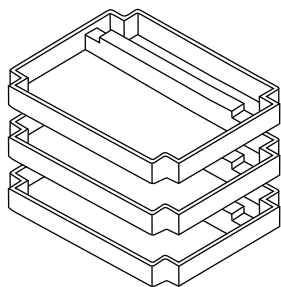

**A** x3

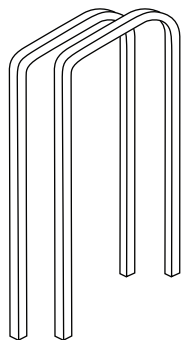

**B** x2

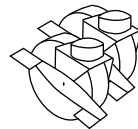

**C** x2

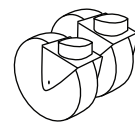

**D** x2

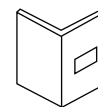

**E** x12

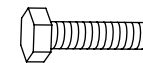

**F** x12



**G** x12



**H** x12



**J** x4



**L** x4

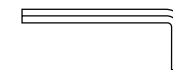

**M** x1

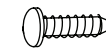

**K** x4

- 1** Take one Tubular Frame **B** and lay flat. Hold Molded Tray **A** to desired height.

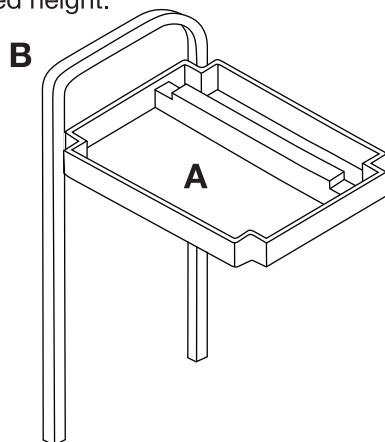

- 2** Gather 2 Angle Brace **E**, 2 Hex Bolt **F**, 2 Washer **G** and 2 Nut **H** pieces. Put Washer **G** onto Hex Bolt **F**. Then, insert the combined pieces into the hole on Tubular Frame **B** coming from the outside.

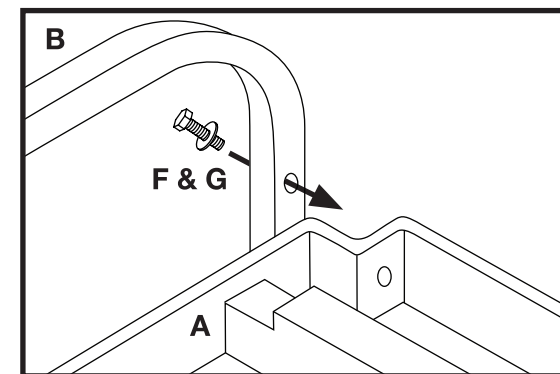
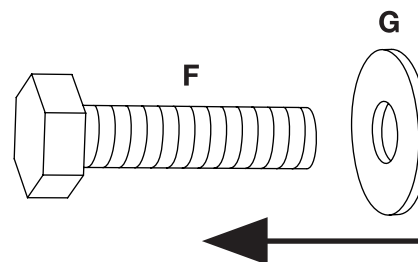

- 3** Take Angle Brace **E** and put it on the inside of Molded Tray **A** over Hex Bolt **F**. Take Nut **H** and put it on the end of Hex Bolt **F** and tighten.  
**Note:** Do not tighten screws all the way.

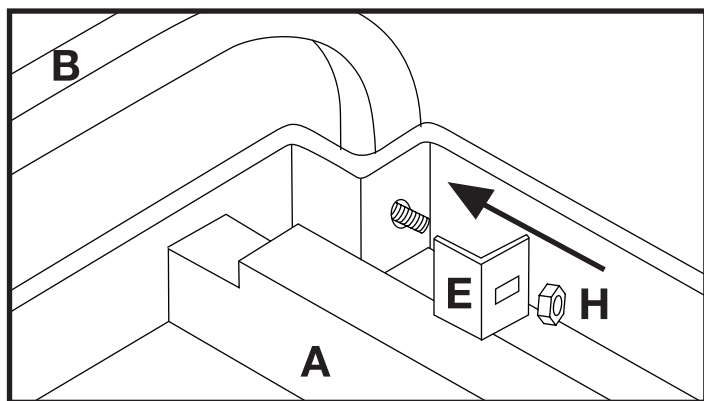

- 4** Attach the 2 remaining Molded Tray **A** pieces onto the Tubular Frame **B** as Step 1. Assemble the second Tubular Frame **B** onto the other side of the Molded Tray **A** pieces.

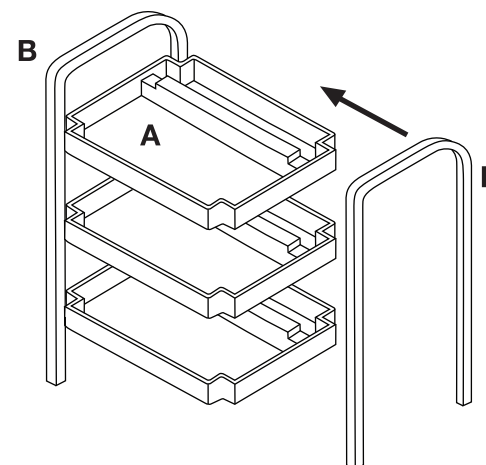

- 5** Gather 2 Caster **C**, 2 Caster **D**, 4 Spring Washer **L**, 4 Screw **K**, and 4 Ring Seater **J**. Put 1 Ring Seater **J** over the stem of Caster **C** and 1 over the stem of Caster **D**. Then put Spring Washer **L** over Screw **K**. Repeat for all of the pieces.

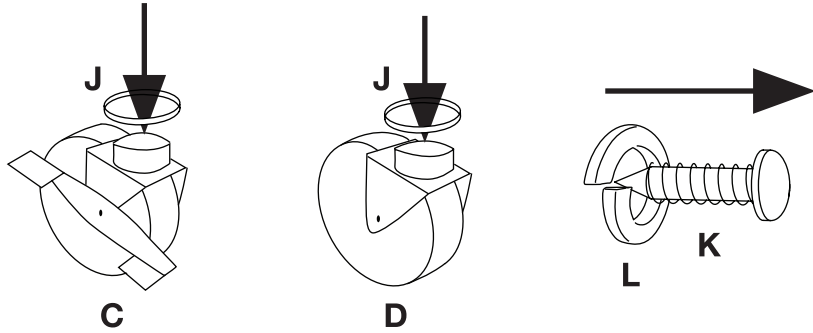

- 6** Hold Caster **C** (with Ring Seater **J** on it) up in the bottom of Tubular Frame **B**. Insert Screw **K** (with Spring Washer **L** on it) into the frame and using Hex Wrench **M**, secure the Caster. Do the same with all of the Casters.  
**Note:** Both Caster **C** pieces should be attached on the same side as shown.  
**Note:** Once Casters are attached, go back and tighten all Screws until secure.

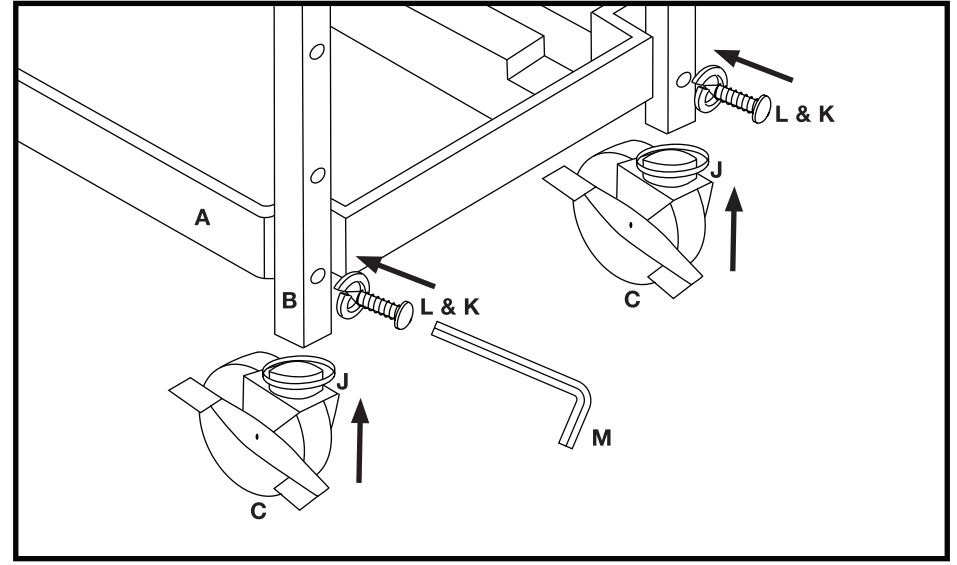

- 7** Completed Product

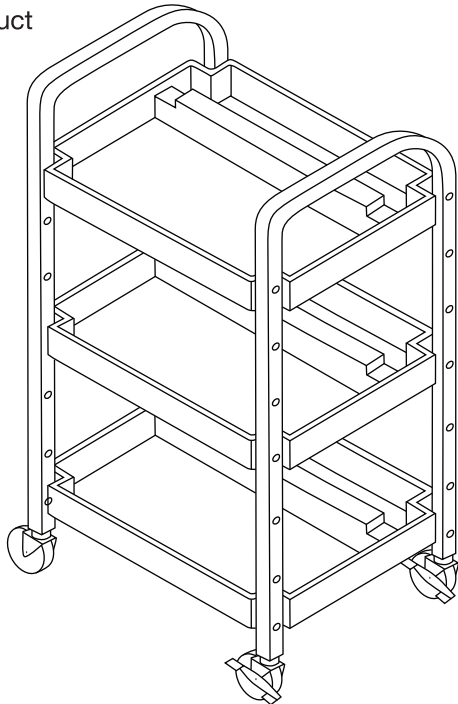

For Questions about this product  
call 800-323-4656 or email us at  
[customerservice@luxorfurn.com](mailto:customerservice@luxorfurn.com)